

**INTERNATIONAL CODE COUNCIL
2012/2013 CODE DEVELOPMENT CYCLE
Group A (2012)**

**PROPOSED CHANGES TO THE
2012 EDITIONS OF THE**

INTERNATIONAL BUILDING CODE®

INTERNATIONAL FUEL GAS CODE®

INTERNATIONAL MECHANICAL CODE®

INTERNATIONAL PLUMBING CODE®

*INTERNATIONAL PRIVATE SEWAGE DISPOSAL
CODE®*



**April 29th – May 8th, 2012
Sheraton Dallas Hotel
Dallas, TX**

First Printing

Publication Date: March 2012

Copyright © 2012

By

International Code Council, Inc.

ALL RIGHTS RESERVED. This 2012/2013 Code Development Cycle, Group A (2012) Proposed Changes to the 2012 *International Codes* is a copyrighted work owned by the International Code Council, Inc. Without advanced written permission from the copyright owner, no part of this book may be reproduced, distributed, or transmitted in any form or by any means, including, without limitations, electronic, optical or mechanical means (by way of example and not limitation, photocopying, or recording by or in an information storage retrieval system). For information on permission to copy material exceeding fair use, please contact: Publications, 4051 West Flossmoor Road, Country Club Hills, IL 60478 (Phone 1-888-422-7233).

Trademarks: "International Code Council," the "International Code Council" logo are trademarks of the International Code Council, Inc.

PRINTED IN THE U.S.A.

TABLE OF CONTENTS (Group A)

	PAGE
Introduction	ii
2012 ICC Code Development Hearings	ii
Registration and Voting	ii
Advanced Registration.....	iii
Code Development Process Changes	iii
Procedures.....	iii
Assembly Action	iv
Multiple Part Code Change Proposals	iv
Group A and B Code Changes by Committee	v
Group A Code Development Committee Responsibilities.....	vi
Analysis Statements	vi
Reference Standards.....	vi
Referenced Standards Updates.....	vi
Modifications	vii
Code Correlation Committee	viii
ICC Website	viii
2012/2013 Code Development Schedule.....	ix
2012/2013 Staff Secretaries.....	x
Assignment Crossover — Within the IBC.....	xi
CP #28-05 Code Development	xii
Cross Index of Proposed Changes	xxiv
Hearing Schedule	xxix
2012 Proposed Changes	xxx

INTRODUCTION

The proposed changes published herein have been submitted in accordance with established procedures and are distributed for review. The publication of these changes constitutes neither endorsement nor question of them but is in accordance with established procedures so that any interested individuals may make their views known to the relevant code committee and others similarly interested. In furtherance of this purpose, the committee will hold an open public hearing at the date and place shown below for the purpose of receiving comments and arguments for or against such proposed changes. Those who are interested in testifying on any of the published changes are expected to be represented at these hearings.

This compilation of code change proposals is available in electronic form only. As part of ICC's green initiative, ICC will no longer print and distribute this document. The compilation of code change proposals will be posted on the ICC website, and CD copies will be distributed to all interested parties on our list.

2012 ICC CODE DEVELOPMENT HEARINGS

These proposed changes will be discussed in public hearings to be held on April 29th, 2012 through May 8th, 2012 at the Sheraton Dallas Hotel, Dallas, Texas. The code committees will conduct their public hearings in accordance with the schedule shown on page xxix.

REGISTRATION AND VOTING

All members of ICC may vote on any assembly motion on proposed code changes to all International Codes. **For identification purposes, eligible voting members must register, at no cost, in order to vote.** The registration desk will be open in the lobby of the convention center according to the following schedule:

Saturday, April 28 th	4:00 pm to 6:00 pm
Sunday, April 29 th through Tuesday, May 8 th	7:30 am to 5:00 pm

Council Policy #28-Code Development (page xii) requires that ICC's membership records regarding ICC members reflect the eligible voters 10 days prior to the start of the Code Development Hearings. This process includes new as well as changes to voting status. Section 5.7.4 of CP #28 (page xix) reads as follows:

5.7.4 Eligible Voters: All members of ICC in attendance at the public hearing shall be eligible to vote on floor motions. Each member is entitled to one vote, except that each Governmental Member Voting Representative in attendance may vote on behalf of its Governmental Member. Code Development Committee members shall be eligible to vote on floor motions. Application, whether new or updated, for ICC membership must be received by the Code Council ten days prior to the commencement of the first day of the public hearing.

As such, new membership applications as well as renewal applications must be received by ICC's Member Services Department by April 18th, 2012. These records will be used to verify eligible voter status for the Code Development Hearings. Members are strongly encouraged to review their membership records for accuracy well in advance of the hearings so that any necessary changes are made prior to the April 18th, 2012 deadline. For information on application for new membership and membership renewal, please go to www.iccsafe.org/membership/join.html or call ICC Member Services at 1-888-ICC SAFE (422-7233)

It should be noted that a corporate member has a single vote. Only one representative of a corporate member will be issued a voting badge. ICC Staff will be contacting corporate members regarding who the designated voting representative will be.

ADVANCED REGISTRATION

You are encouraged to advance register by filling out the registration form available at www.iccsafe.org/springhearings.

CODE DEVELOPMENT PROCESS CHANGES

As noted in the posted Advisory Statement of February 4, 2009, the revised Code Development Process includes maintaining the current 3-year publication cycle with a single cycle of code development between code editions. The schedule for the 2012/2013 Code Development Cycle is the first schedule for the revised code development process (see page ix).

PROCEDURES

The procedures for the conduct of the public hearing are published in *Council Policy #28-Code Development (CP#28)* (“Procedures”) on page xii. The attention of interested parties is specifically directed to Section 5.0 of the Procedures. These procedures indicate the conduct of, and opportunity to participate in the ICC Code Development Process. Please review these procedures carefully to familiarize yourself with the process.

There have been a number of revisions to the procedures. Included among these revisions are the following:

- Section 1.6: **Recording.** This section was revised to clarify that ICC maintains sole ownership in the content of the hearings and has the right to control its subsequent distribution. In addition, the technology references were updated, using the term “recording” to replace “videotaping”.

- Section 2.4 **Emergency Procedures.** This section was revised create a 'metric' to aid in the determination of when an issue rises to the level of concern appropriate to an emergency amendment. Furthermore, it now stipulates a process by which a proposed Emergency Amendment is reviewed by the ICC Codes and Standards Council who is responsible for the implementation and oversight of ICC’s Code Development Process.

- Section 3.3.1
&
Section 6.4.1 **Proponent.** An e-mail address for each code change/public comment proponent will be published in the monograph, unless the proponent requests otherwise.

- Section 3.3.5.3
&
Section 6.4.5 **Substantiation.** ICC evaluates whether substantiating material is germane, but the amendment makes it clear that ICC does not in all circumstances evaluate substantiating material for quality or accuracy.

- Section 3.3.5.6 **Cost Impact.** The proponent should submit information that supports their claim regarding cost impact. Any information submitted will be considered by the code development committee. This language is intended to emphasize the need to provide information on how the proposed change will affect the cost of construction.

- Section 3.6.3.1 If a proposed new standard is not submitted in at least draft form, the corresponding code change proposal shall be considered incomplete and shall not be processed.

- Section 4.5.1 **Standards referenced in the I-Codes.** The deadline for availability of updated referenced standards and receipt by the Secretariat is December 1st of the third year of each code cycle. For the 2012/2013 cycle, the deadline is December 1st, 2014.

- Section 5.2.2 **Conflict of interest.** The original language, “Violation thereof shall result in the immediate removal of the committee member from the committee.” was removed because there was no mechanism to enforce it. The recourse for someone who feels this section has been violated is to appeal.
- Section 5.4.2 **Open meetings.** A provision has been added that stipulates that participants shall not advocate a position on specific code changes with Committee Members other than through the methods provided in this policy.
- Section 5.4.3
&
Section 7.3.3 **Presentation of Material at the Public Hearing.** All participants are to make it clear what interests they are representing. This disclosure provides additional information upon which to evaluate the testimony.
- Section 5.7 **Assembly consideration.** A successful assembly action will no longer be the initial motion at the Final Action Consideration.
- Section 5.7.3 **Assembly action.** A successful assembly action shall be a majority vote of the votes cast by eligible voters, rather than a 2/3 majority (see below).
- Section 5.7.4 **Eligible voters.** This section is revised to clarify that each member, including Governmental Member Voting Representatives, gets only one vote.
- Section 7.4 **Eligible voters.** This section requires that all Governmental Membership applications must be received by April 1 of the year of the Final Actions for a Governmental Member to be eligible to vote at the Final Action Hearings.

ASSEMBLY ACTION

The procedures regarding assembly action at the Code Development Hearings have been revised (see Section 5.7 of CP #28 on page xix). Some important items to note regarding assembly action are:

- A successful assembly action now requires a simple majority rather than a 2/3 majority.
- After the committee decision on a code change proposal is announced by the moderator, any one in the assembly may make a motion for assembly action.
- After a motion for assembly action is made and seconded, the moderator calls for a floor vote in accordance with Section 5.7.2. *No additional testimony will be permitted.*
- A code change proposal that receives a successful assembly action will be placed on the Final Action Hearing Agenda for individual consideration.

MULTIPLE PART CODE CHANGE PROPOSALS

It is common for ICC to receive code change proposals for more than one code or more than 1 part of a code that is the responsibility of more than one committee. For instance, a code change proposal could be proposing related changes to the text of IBC Chapter 4 (IBC-General), IBC Chapter 7 (IBC-Fire Safety), and the IFC Chapter 27 (IFC). When this occurs, a single committee will now hear all of the parts, unless one of the parts is a change to the IRC, in which case the respective IRC committee will hear that part separately.

GROUP A AND GROUP B CODE CHANGES

Starting with this 2012/2013 Code Development Cycle, for the development of the 2015 Edition of the I-Codes, there are two groups of code development committees and they will meet in separate years. The groupings are as follows:

Group A Codes (Heard in 2012)	Group B Codes (Heard in 2013)
<i>International Building Code Committees:</i> <i>IBC-Fire Safety (Chapters: 7, 8, 9, 14, 26 and App. D)</i> <i>IBC-General (Chapters: 2-6, 12, 13, 27-34, App. A, B, C, F, H, K)</i> <i>IBC-Means of Egress (Chapters: 10, 11 and App. E)</i> <i>IBC-Structural (Chapters: 15-25 and App. G,I, J, L, M)</i>	<i>Administrative Provisions (Chapter 1 all codes except IRC and IECC, referenced standards administrative updates, and designated definitions)</i> <i>Administrative Code Committee</i>
<i>International Fuel Gas Code</i> <i>IFGC Committee</i>	<i>International Energy Conservation Code (see note 1)</i> <i>Commercial Energy Committee</i> <i>Residential Energy Committee</i>
<i>International Mechanical Code</i> <i>IMC Committee</i>	<i>International Existing Building Code</i> <i>IEBC Committee</i>
<i>International Plumbing Code</i> <i>IPC Committee</i>	<i>International Fire Code</i> <i>IFC Committee</i>
<i>International Private Sewage Disposal Code</i> <i>IPC Committee</i>	<i>International Green Construction Code Committees:</i> <i>IGCC—Energy/Water Committee (Chapters: 6 and 7)</i> <i>IGCC—General Committee (Chapters:2-5, 8-11 and Append)</i>
	<i>International Performance Code (see note 2)</i> <i>ICC Performance Code Committee</i>
	<i>International Property Maintenance Code</i> <i>IPMC/IZC Committee</i>
	<i>International Wildland-Urban Interface Code</i> <i>IFC Committee</i>
	<i>International Zoning Code</i> <i>IPMC/IZC Committee</i>
	<i>International Residential Code Committees:</i> <i>IRC-B (Chapters: 1-10 and App. E, F, G,H, J, K, L, M, O)</i> <i>IRC-M/P (Chapters: 12-33 and App. I, P)</i>
	<i>International Swimming Pool and Spa Code</i> <i>ISPSC Committee</i>

NOTE:

1. Residential Energy Committee is responsible for Chapter 11 of the IRC and the Residential Provisions of the IECC.
2. In anticipation of minimal code change activity, a ICC Performance Committee has not been appointed. Any changes will be considered by the IFC Committee.

GROUP A CODE DEVELOPMENT COMMITTEE RESPONSIBILITIES

Some sections of the International Codes have a letter designation in brackets in front of them. For instance, Section 301.1.4 of the IEBC has a [B] in front of it, meaning that this section is the responsibility of one of the IBC Code Development Committees (in this case, IBC-S).

Code change proposals submitted for such code sections that have a bracketed letter designation in front of them will be heard by the respective committee responsible for such code sections. Because different committees will meet in different years, some proposals for a given code will be heard by a committee in a different year than the year in which the primary committee for this code meets.

Note that there are several code change proposals in the IBC-Structural hearing order that are changes to the International Existing Building Code (marked with prefix "EB"). These are proposed changes to sections of the existing building code that are the responsibility of the IBC-Structural Code Development Committee. A complete summary of the Group A and Group B Code Development Committees' responsibilities can be view at the ICC Website: http://www.iccsafe.org/cs/codes/Documents/2012-13cycle/GroupA-B_CDC-Responsibilities.pdf.

ANALYSIS STATEMENTS

Various proposed changes published herein contain an "analysis" that appears after the proponent's reason. These comments do not advocate action by the code committees or the voting membership for or against a proposal. The purpose of such comments is to identify pertinent information that is relevant to the consideration of the proposed change by all interested parties, including those testifying, the code committees and the voting membership. Staff analyses customarily identify such things as: conflicts and duplication within a proposed change and with other proposed changes and/or current code text; deficiencies in proposed text and/or substantiation; text problems such as wording defects and vagueness; background information on the development of current text; and staff's review of proposed reference standards for compliance with the Procedures. Lack of an analysis indicates neither support for, nor opposition to a proposal.

REFERENCE STANDARDS

Proposed changes that include the addition of a reference to a new standard (i.e. a standard that is not currently referenced in the I-Codes.) will include in the proposal the number, title and edition of the proposed standard. This identifies to all interested parties the precise document that is being proposed and which would be included in the referenced standards chapter of the code if the proposed change is approved. Section 3.6.3.1 of CP #28 now requires that a code change proposal will not be processed unless a consensus draft of the standard has been provided. Proponents of code changes which propose a new standard have been directed to forward copies of the standard to the Code Committee. An analysis statement will be posted on the ICC website providing information regarding standard content, such as enforceable language, references to proprietary products or services, and references to consensus procedure. The analysis statements for referenced standards will be posted on or before March 28th, 2012. This information will also be published and made available at the hearings.

REFERENCED STANDARDS UPDATES

Administrative updates of any standards already referenced in any of the I-Codes will be contained in a code change proposal for consideration by the Administrative Code Development Committee. The Administrative Code Development Committee is a Group B committee which will conduct hearings on the administrative provisions (Chapter 1 and certain definitions) of all I-Codes, and the referenced standards update. Therefore, this committee will conduct its code development hearing during the code development hearings in 2013.

It should be noted that, in accordance with Section 4.5.1 of CP #28 (see page xvi), standards promulgators will have until December 1, 2014 to finalize and publish any updates to standards in the administrative update. If the standard update is not finalized and published by December 1, 2014, the respective I-Codes will be revised to reference the previously listed year edition of the standard.

MODIFICATIONS

Those who are submitting a modification for consideration by the respective Code Development Committee are required to submit a Copyright Release in order to have their modifications considered (Section 3.3.4.5 of CP #28). It is preferred that such release be executed in advance – the form is at <http://www.iccsafe.org/cs/codes/publicforms.htm>. Copyright release forms will also be available at the hearings. Please note that an individual need only sign one copyright release for submittals of all code change proposals, modifications, and public comments in this code change cycle for which the individual might be responsible. **Please be sure to review Section 5.5.2 of CP #28 for the modification process.** The Chair of the respective code development committee rules a modification in or out of order. That ruling is final, with no challenge allowed. The proponent submitting a modification is required to supply 20 printed copies. The minimum font size must be 16 point.

Example:

Original code change proposal.

The original code change proposal requested the following change to Section 305.3 of one of our I-Codes: (Note that the example is fictional.)

G10-12 305.13

Proponent: John West representing self

Revise as follows:

305.3 Interior surfaces. All interior surfaces, including windows and doors, shall be maintained in good and clean condition. Peeling, chipping, flaking or abraded paint shall be repaired, removed or covered. Cracked or loose plaster, ~~decayed wood~~ and other defective surface conditions shall be corrected. Surfaces of porous materials made of or containing organic materials, such as but not limited to wood, textiles, paint, cellulose insulation, and paper, including paper-faced gypsum board, that have visible signs of mold or mildew shall be removed and replaced or remediated in an approved manner.

Exception: Porous materials that do not contain organic materials, such as clean unpainted bricks and concrete.

Proposed modification:

A modification to the code change proposal is proposed:

1. To add “and sanitary” after “clean” in the first sentence.
2. To add “or water permeable” after “porous” in the third sentence.
3. Delete “in an approved manner.” in the last sentence.
4. Delete the proposed new exception.

The modification should read as follows. Note that the font style is Ariel, and the font size is 16 pt. The ~~cross-out, underline~~ format is removed from the text of the original proposal and the requested revisions in the original proposal are made and shown as original text. The modification to the original proposal is shown with ~~cross-out, underline~~ format applied to the changes proposed in the modification.

Example of proposed modification:

G10-12
305.13

Proponent: Sam Sumter representing self

Modify the proposal as follows:

305.3 Interior surfaces. All interior surfaces, including windows and doors, shall be maintained in good, ~~and~~ clean and sanitary condition. Peeling, chipping, flaking or abraded paint shall be repaired, removed or covered. Cracked or loose plaster and other defective surface conditions shall be corrected. Surfaces of porous or water permeable materials made of or containing organic materials, such as but not limited to wood, textiles, paint, cellulose insulation, and paper, including paper-faced gypsum board, that have visible signs of mold or mildew shall be removed and replaced or remediated ~~in an approved manner.~~

Exception: ~~Porous materials that do not contain organic materials, such as clean unpainted bricks and concrete.~~

Note: The modification should be able to be shown on the overhead screen on a single page. Only show the pertinent part of the code change proposal that shows the intended revisions. The entire code change proposal need not be shown.

CODE CORRELATION COMMITTEE

In every code change cycle, there are code change proposals that are strictly editorial. The Code Correlation Committee approves all proposals deemed editorial. A list of code correlation committee actions are shown at the end of this document (CCC-1).

ICC WEBSITE – [WWW.ICCSAFE.ORG](http://www.iccsafe.org)

This document is posted on the ICC Website, www.iccsafe.org. While great care has been exercised in the publication of this document, errata to proposed changes may occur. Errata, if any, will be identified in updates posted prior to the Code Development Hearings on the ICC website at <http://www.iccsafe.org>. Users are encouraged to periodically review the ICC Website for updates to the 2012/2013 Code Development Cycle-Group A (2012) Proposed Changes. Additionally, analysis statements for code changes which propose a new referenced standard will be updated to reflect the staff review of the standard for compliance with Section 3.6 of the Procedures.

PROPONENT CONTACT INFORMATION

For most of the code change proposals, an e-mail address for the proponent has been provided.

2012/2013 ICC CODE DEVELOPMENT SCHEDULE

STEP IN CODE DEVELOPMENT CYCLE	DATE	
	2012 – Group A Codes IBC, IFGC, IMC, IPC, IPSDC (See Notes)	2013 – Group B Codes Admin, ICCPC, IEBC, IECC, IFC, IgCC, IPMC, ISPSC, IRC, IWUIC, IZC (See Notes)
2012 EDITION OF I-CODES PUBLISHED	April 30, 2011	
DEADLINE FOR RECEIPT OF APPLICATIONS FOR ALL CODE COMMITTEES	June 1, 2011 (updated to July 1 for IECC and IRC – Energy; August 1 for IgCC and ISPSC)	
DEADLINE FOR RECEIPT OF CODE CHANGE PROPOSALS	January 3, 2012	January 3, 2013
WEB POSTING OF “PROPOSED CHANGES TO THE I-CODES”	March 12, 2012	March 11, 2013
DISTRIBUTION DATE OF “PROPOSED CHANGES TO THE I-CODES” (CD only)	April 2, 2012	April 1, 2013
CODE DEVELOPMENT HEARING (CDH)	April 29 – May 6, 2012 Sheraton Dallas Hotel Dallas, TX	April 21 – 28, 2013 Sheraton Dallas Hotel Dallas, TX
WEB POSTING OF “REPORT OF THE PUBLIC HEARING”	June 8, 2012	May 31, 2013
DISTRIBUTION DATE OF “REPORT OF THE PUBLIC HEARING” (CD only)	June 29, 2012	June 21, 2013
DEADLINE FOR RECEIPT OF PUBLIC COMMENTS	August 1, 2012	July 15, 2013
WEB POSTING OF PUBLIC COMMENTS “FINAL ACTION AGENDA”	September 10, 2012	August 28, 2013
DISTRIBUTION DATE OF PUBLIC COMMENTS “FINAL ACTION AGENDA” (CD only)	October 1, 2012	September 16, 2013
FINAL ACTION HEARING (FAH)	October 24 – 28, 2012 Oregon Convention Center Portland, OR	October 2 – 9, 2013 Atlantic City Convention Center Atlantic City, NJ
ANNUAL CONFERENCES	October 21 – 24, 2012 Oregon Convention Center Portland, OR	September 29 – October 2, 2013 Atlantic City Convention Center Atlantic City, NJ

Notes:

- Be sure to review the “Group A and Group B Code Development Committee Responsibilities” posted at www.iccsafe.org/responsibilities which identifies committee responsibilities which are different than Group A and Group B codes which may impact the applicable code change cycle and resulting code change deadline.
- The International Green Construction Code (IgCC) and International Swimming Pool and Spa Code (ISPSC) to undergo a full cycle of code development in 2011 resulting in 2012 editions published in March/2012
- Group B “Admin” includes code change proposals submitted to Chapter 1 of all the I-Codes except the ICCPC, IECC and IRC and the administrative update of referenced standards in the 2012 I-Codes
- Start 2015/2016 Code Development Cycle with Group A code change proposals due January 5, 2015

2012/2013 STAFF SECRETARIES

GROUP A (2012)

IBC-Fire Safety Chapters 7, 8, 9, 14, 26	IBC-General Chapters 1-6, 12, 13, 27-34	IBC-Means of Egress Chapters 10, 11	IBC-Structural Chapters 15-25
Ed Wirtschoreck ICC Chicago District Office 1-888-ICC-SAFE, ext 4317 FAX: 708/799-0320 ewirtschoreck@iccsafe.org	Beth Tubbs ICC Northbridge Field Office 1-888-ICC-SAFE, ext 7708 FAX: 419/ 730-6531 btubbs@iccsafe.org	Kim Paarlberg ICC Indianapolis Field Office 1-888-ICC-SAFE, ext 4306 FAX: 708/799-0320 kpaarlberg@iccsafe.org	Alan Carr ICC NW Resource Center 1-888-ICC-SAFE, ext 7601 FAX: 425/637-8939 acarr@iccsafe.org
IFGC	IMC	IPC/IPSDC	
Gregg Gress ICC Chicago District Office 1-888-ICC-SAFE, ext 4343 FAX: 708/799-0320 ggress@iccsafe.org	Gregg Gress ICC Chicago District Office 1-888-ICC-SAFE, ext 4343 FAX: 708/799-0320 ggress@iccsafe.org	Fred Grable ICC Chicago District Office 1-888-ICC-SAFE, ext 4359 FAX: 708/799-0320 fgrable@iccsafe.org	

GROUP B (2013)

ADMINISTRATIVE Chapter 1 All Codes Except IRC	IEBC	IECC-Commercial	IECC-Residential
Kim Paarlberg ICC Indianapolis Field Office 1-888-ICC-SAFE, ext 4306 FAX: 708/799-0320 kpaarlberg@iccsafe.org	Beth Tubbs ICC Northbridge Field Office 1-888-ICC-SAFE, ext 7708 FAX: 419/ 730-6531 btubbs@iccsafe.org	Dave Bowman ICC Chicago District Office 1-888-ICC-SAFE, ext 4323 FAX: 708/799-0320 dbowman@iccsafe.org	Dave Bowman ICC Chicago District Office 1-888-ICC-SAFE, ext 4323 FAX: 708/799-0320 dbowman@iccsafe.org
IFC	IgCC-General	IgCC-Energy/Water	ICC PC
Bill Rehr/ Beth Tubbs ICC Chicago District Office 1-888-ICC-SAFE, ext 4342 FAX: 708/799-0320 brehr@iccsafe.org btubbs@iccsafe.org	Allan Bilka ICC Chicago District Office 1-888-ICC-SAFE, ext 4326 FAX: 708/799-0320 abilka@iccsafe.org	Fred Grable ICC Chicago District Office 1-888-ICC-SAFE, ext 4359 FAX: 708/799-0320 fgrable@iccsafe.org	Beth Tubbs ICC Northbridge Field Office 1-888-ICC-SAFE, ext 7708 FAX: 419/ 730-6531 btubbs@iccsafe.org
IPMC	IRC-Building	IRC Mechanical	IRC Plumbing
Ed Wirtschoreck ICC Chicago District Office 1-888-ICC-SAFE, ext 4317 FAX: 708/799-0320 ewirtschoreck@iccsafe.org	Larry Franks/ Dave Bowman ICC Birmingham District Office 1-888-ICC-SAFE, ext 5279 FAX: 205/592-7001 lfranks@iccsafe.org dbowman@iccsafe.org	Gregg Gress ICC Chicago District Office 1-888-ICC-SAFE, ext 4343 FAX: 708/799-0320 ggress@iccsafe.org	Fred Grable ICC Chicago District Office 1-888-ICC-SAFE, ext 4359 FAX: 708/799-0320 fgrable@iccsafe.org
ISPSC	IWUIC	IZC	
Fred Grable ICC Chicago District Office 1-888-ICC-SAFE, ext 4359 FAX: 708/799-0320 fgrable@iccsafe.org	Bill Rehr ICC Chicago District Office 1-888-ICC-SAFE, ext 4342 FAX: 708/799-0320 brehr@iccsafe.org	Ed Wirtschoreck ICC Chicago District Office 1-888-ICC-SAFE, ext 4317 FAX: 708/799-0320 ewirtschoreck@iccsafe.org	

COMMITTEE A ASSIGNMENT CROSSOVER LIST—WITHIN THE IBC

The 2012/2013 Staff Secretaries assignments on page x indicate which chapters of the International Building Code are generally within the responsibility of each IBC Code Committee. However, within each of these IBC Chapters are subjects that are most appropriately maintained by another IBC Code Committee. For example, the provisions of Section 403.5 deal with means of egress from high-rise buildings. Therefore, even though Chapter 4 is within the responsibility of the IBC – General Committee, this section would most appropriately be maintained by the IBC – Means of Egress Committee. The following table indicates responsibilities by IBC Code Committees other than the main committee for those chapters, for code changes submitted for the 2012 portion (Group A) of the 2012/2013 Cycle.

SECTION	CHAPTER MAINTAINED BY	SECTION MAINTAINED BY	CODE CHANGE PROPOSALS
403.5	IBC-General	IBC-Means of Egress	E4, E7
405.7.1	IBC-General	IBC-Means of Egress	E3
411.7	IBC-General	IBC-Means of Egress	E3
1508.1	IBC-Structural	IBC-Fire Safety	FS178
3401.2	IBC-General	IBC-Structural	S90
3406.1.3	IBC-General	IBC-Means of Egress	E4
3406.4	IBC-General	IBC-Means of Egress	E4
3411.8.4	IBC-General	IBC-Means of Egress	E4
3411.8.15	IBC-General	IBC-Means of Egress	E211



CP# 28-05 CODE DEVELOPMENT

Approved: 9/24/05
Revised: 10/29/11

CP # 28-05 is an update to ICC's *Code Development Process for the International Codes* dated May 15, 2004.

1.0 Introduction

- 1.1 **Purpose:** The purpose of this Council Policy is to prescribe the Rules of Procedure utilized in the continued development and maintenance of the International Codes (Codes).
- 1.2 **Objectives:** The ICC Code Development Process has the following objectives:
 - 1.2.1 The timely evaluation and recognition of technological developments pertaining to construction regulations.
 - 1.2.2 The open discussion of proposals by all parties desiring to participate.
 - 1.2.3 The final determination of Code text by public officials actively engaged in the administration, formulation or enforcement of laws, ordinances, rules or regulations relating to the public health, safety and welfare and by honorary members.
- 1.3 **Code Publication:** The ICC Board of Directors (ICC Board) shall determine the title and the general purpose and scope of each Code published by the ICC.
 - 1.3.1 **Code Correlation:** The provisions of all Codes shall be consistent with one another so that conflicts between the Codes do not occur. Where a given subject matter or code text could appear in more than one Code, the ICC Board shall determine which Code shall be the primary document, and therefore which code development committee shall be responsible for review and maintenance of the code text. Duplication of content or text between Codes shall be limited to the minimum extent necessary for practical usability of the Codes, as determined in accordance with Section 4.4.
- 1.4 **Process Maintenance:** The review and maintenance of the Code Development Process and these Rules of Procedure shall be by the ICC Board. The manner in which ICC codes are developed embodies core principles of the organization. One of those principles is that the final content of ICC codes is determined by a majority vote of the governmental and honorary members. It is the policy of the Board that there shall be no change to this principle without the affirmation of two-thirds of the governmental and honorary members responding.
- 1.5 **Secretariat:** The Chief Executive Officer shall assign a Secretariat for each of the Codes. All correspondence relating to code change proposals and public comments shall be addressed to the Secretariat.
- 1.6 **Recording:** Individuals requesting permission to record any meeting or hearing, or portion thereof, shall be required to provide the ICC with a release of responsibility disclaimer and shall acknowledge that ICC shall retain sole ownership of the recording, and that they have insurance coverage for liability and misuse of recording materials. Equipment and the process used to record shall, in the judgment of the ICC Secretariat, be conducted in a manner that is not disruptive to the meeting. The ICC shall not be responsible for equipment, personnel or any other provision necessary to accomplish the recording. An unedited copy of the recording shall be forwarded to ICC within 30 days of the meeting. Recordings shall not otherwise be copied, reproduced or distributed in any manner. Recordings shall be returned to

ICC or destroyed upon the request of ICC.

2.0 Code Development Cycle

- 2.1 Intent:** The code development cycle shall consist of the complete consideration of code change proposals in accordance with the procedures herein specified, commencing with the deadline for submission of code change proposals (see Section 3.5) and ending with publication of final action on the code change proposals (see Section 7.6).
- 2.2 New Editions:** The ICC Board shall determine the schedule for publishing new editions of the Codes. Each new edition shall incorporate the results of the code development activity since the last edition.
- 2.3 Supplements:** The results of code development activity between editions may be published.
- 2.4 Emergency Procedures:**
- 2.4.1 Scope:** Emergency actions are limited to those issues representing an immediate threat to health and safety that warrant a more timely response than allowed by the Code Development Process schedule.
- 2.4.2 Initial Request:** A request for an emergency action shall be based upon perceived threats to health and safety and shall be reviewed by the ICC Codes and Standards Council for referral to the Board of Directors for action with their analysis and recommendation.
- 2.4.3 Board and Member Action:** In the event that the ICC Board determines that an emergency amendment to any Code is warranted, the same may be adopted by the ICC Board. Such action shall require an affirmative vote of at least two-thirds of the ICC Board.

The ICC membership shall be notified within ten days after the ICC Boards' official action of any emergency amendment. At the next Annual Business Meeting, any emergency amendment shall be presented to the members for ratification by a majority of the ICC Governmental Member Representatives and Honorary Members present and voting.

All code revisions pursuant to these emergency procedures and the reasons for such corrective action shall be published as soon as practicable after ICC Board action. Such revisions shall be identified as an emergency amendment.

Emergency amendments to any Code shall not be considered as a retro-active requirement to the Code. Incorporation of the emergency amendment into the adopted Code shall be subjected to the process established by the adopting authority.

3.0 Submittal of Code Change Proposals

- 3.1 Intent:** Any interested person, persons or group may submit a code change proposal which will be duly considered when in conformance to these Rules of Procedure.
- 3.2 Withdrawal of Proposal:** A code change proposal may be withdrawn by the proponent (WP) at any time prior to Final Action Consideration of that proposal. A withdrawn code change proposal shall not be subject to a public hearing, motions, or Final Action Consideration.
- 3.3 Form and Content of Code Change Submittals:** Each code change proposal shall be submitted separately and shall be complete in itself. Each submittal shall contain the following information:
- 3.3.1 Proponent:** Each code change proposal shall include the name, title, mailing address, telephone number, and email address of the proponent. Email addresses shall be published with the code change proposals unless the proponent otherwise requests on the submittal form.
- 3.3.1.1** If a group, organization or committee submits a code change proposal, an individual with prime responsibility shall be indicated.
- 3.3.1.2** If a proponent submits a code change on behalf of a client, group, organization or committee, the name and mailing address of the client, group, organization or committee shall be indicated.

- 3.3.2 Code Reference:** Each code change proposal shall relate to the applicable code sections(s) in the latest edition of the Code.
- 3.3.2.1** If more than one section in the Code is affected by a code change proposal, appropriate proposals shall be included for all such affected sections.
- 3.3.2.2** If more than one Code is affected by a code change proposal, appropriate proposals shall be included for all such affected Codes and appropriate cross referencing shall be included in the supporting information.
- 3.3.3 Multiple code change proposals to a code section.** A proponent shall not submit multiple code change proposals to the same code section. When a proponent submits multiple code change proposals to the same section, the proposals shall be considered as incomplete proposals and processed in accordance with Section 4.3. This restriction shall not apply to code change proposals that attempt to address differing subject matter within a code section.
- 3.3.4 Text Presentation:** The text proposal shall be presented in the specific wording desired with deletions shown struck out with a single line and additions shown underlined with a single line.
- 3.3.4.1** A charging statement shall indicate the referenced code section(s) and whether the proposal is intended to be an addition, a deletion or a revision to existing Code text.
- 3.3.4.2** Whenever practical, the existing wording of the text shall be preserved with only such deletions and additions as necessary to accomplish the desired change.
- 3.3.4.3** Each proposal shall be in proper code format and terminology.
- 3.3.4.4** Each proposal shall be complete and specific in the text to eliminate unnecessary confusion or misinterpretation.
- 3.3.4.5** The proposed text shall be in mandatory terms.
- 3.3.5 Supporting Information:** Each code change proposal shall include sufficient supporting information to indicate how the proposal is intended to affect the intent and application of the Code.
- 3.3.5.1 Purpose:** The proponent shall clearly state the purpose of the proposed code change (e.g. clarify the Code; revise outdated material; substitute new or revised material for current provisions of the Code; add new requirements to the Code; delete current requirements, etc.)
- 3.3.5.2 Reasons:** The proponent shall justify changing the current Code provisions, stating why the proposal is superior to the current provisions of the Code. Proposals which add or delete requirements shall be supported by a logical explanation which clearly shows why the current Code provisions are inadequate or overly restrictive, specifies the shortcomings of the current Code provisions and explains how such proposals will improve the Code.
- 3.3.5.3 Substantiation:** The proponent shall substantiate the proposed code change based on technical information and substantiation. Substantiation provided which is reviewed in accordance with Section 4.2 and determined as not germane to the technical issues addressed in the proposed code change may be identified as such. The proponent shall be notified that the proposal is considered an incomplete proposal in accordance with Section 4.3 and the proposal shall be held until the deficiencies are corrected. The proponent shall have the right to appeal this action in accordance with the policy of the ICC Board. The burden of providing substantiating material lies with the proponent of the code change proposal. All substantiating material published by ICC is material that has been provided by the proponent and in so publishing ICC makes no representations or warranties about its quality or accuracy.
- 3.3.5.4 Bibliography:** The proponent shall submit a bibliography of any substantiating material submitted with the code change proposal. The bibliography shall be published with the code change and the proponent shall make the substantiating materials available for review at the appropriate ICC office and during the public

hearing.

3.3.5.5 Copyright Release: The proponent of code change proposals, floor modifications and public comments shall sign a copyright release reading: "I hereby grant and assign to ICC all rights in copyright I may have in any authorship contributions I make to ICC in connection with any proposal and public comment, in its original form submitted or revised form, including written and verbal modifications submitted in accordance Section 5.5.2. I understand that I will have no rights in any ICC publications that use such contributions in the form submitted by me or another similar form and certify that such contributions are not protected by the copyright of any other person or entity."

3.3.5.6 Cost Impact: The proponent shall indicate one of the following regarding the cost impact of the code change proposal: 1) the code change proposal will increase the cost of construction; or 2) the code change proposal will not increase the cost of construction. The proponent should submit information that supports their claim. Any information submitted will be considered by the code development committee. This information will be included in the bibliography of the published code change proposal.

3.4 Number: One copy of each code change proposal, two copies of each proposed new referenced standard and one copy of all substantiating information shall be submitted. Additional copies may be requested when determined necessary by the Secretariat to allow such information to be distributed to the code development committee. Where such additional copies are requested, it shall be the responsibility of the proponent to send such copies to the respective code development committee. A copy of the code change proposal in electronic form is preferred.

3.5 Submittal Deadline: Each code change proposal shall be received at the office of the Secretariat by the posted deadline. Such posting shall occur no later than 120 days prior to the code change deadline. The submitter of a proposed code change is responsible for the proper and timely receipt of all pertinent materials by the Secretariat.

3.6 Referenced Standards: In order for a standard to be considered for reference or to continue to be referenced by the Codes, a standard shall meet the following criteria:

3.6.1 Code References:

3.6.1.1 The standard, including title and date, and the manner in which it is to be utilized shall be specifically referenced in the Code text.

3.6.1.2 The need for the standard to be referenced shall be established.

3.6.2 Standard Content:

3.6.2.1 A standard or portions of a standard intended to be enforced shall be written in mandatory language.

3.6.2.2 The standard shall be appropriate for the subject covered.

3.6.2.3 All terms shall be defined when they deviate from an ordinarily accepted meaning or a dictionary definition.

3.6.2.4 The scope or application of a standard shall be clearly described.

3.6.2.5 The standard shall not have the effect of requiring proprietary materials.

3.6.2.6 The standard shall not prescribe a proprietary agency for quality control or testing.

3.6.2.7 The test standard shall describe, in detail, preparation of the test sample, sample selection or both.

3.6.2.8 The test standard shall prescribe the reporting format for the test results. The format shall identify the key performance criteria for the element(s) tested.

3.6.2.9 The measure of performance for which the test is conducted shall be clearly defined in either the test standard or in Code text.

3.6.2.10 The standard shall not state that its provisions shall govern whenever the referenced standard is in conflict with the requirements of the referencing Code.

3.6.2.11 The preface to the standard shall announce that the standard is promulgated according to a consensus procedure.

3.6.3 Standard Promulgation:

- 3.6.3.1** Code change proposals with corresponding changes to the code text which include a reference to a proposed new standard or a proposed update of an existing referenced shall comply with this section. The standard shall be completed and readily available prior to Final Action Consideration based on the cycle of code development which includes the proposed code change proposal. In order for a new standard to be considered for reference by the Code, such standard shall be submitted in at least a consensus draft form in accordance with Section 3.4. If a new standard is not submitted in at least draft form, the code change shall be considered incomplete and shall not be processed. Updating of standards without corresponding code text changes shall be accomplished administratively in accordance with Section 4.5.
- 3.6.3.2** The standard shall be developed and maintained through a consensus process such as ASTM or ANSI.

4.0 Processing of Proposals

- 4.1 Intent:** The processing of code change proposals is intended to ensure that each proposal complies with these Rules of Procedure and that the resulting published proposal accurately reflects that proponent's intent.
- 4.2 Review:** Upon receipt in the Secretariat's office, the code change proposals will be checked for compliance with these Rules of Procedure as to division, separation, number of copies, form, language, terminology, supporting statements and substantiating data. Where a code change proposal consists of multiple parts which fall under the maintenance responsibilities of different code committees, the Secretariat shall determine the code committee responsible for determining the committee action in accordance with Section 5.6.
- 4.3 Incomplete Proposals:** When a code change proposal is submitted with incorrect format, without the required information or judged as not in compliance with these Rules of Procedure, the Secretariat shall notify the proponent of the specific deficiencies and the proposal shall be held until the deficiencies are corrected, with a final date set for receipt of a corrected submittal. If the Secretariat receives the corrected proposal after the final date, the proposal shall be held over until the next code development cycle. Where there are otherwise no deficiencies addressed by this section, a proposal that incorporates a new referenced standard shall be processed with an analysis of referenced standard's compliance with the criteria set forth in Section 3.6.
- 4.4 Editorial:** The Chief Executive Officer shall have the authority at all times to make editorial and format changes to the Code text, or any approved changes, consistent with the intent, provisions and style of the Code. An editorial or format change is a text change that does not affect the scope or application of the code requirements.
- 4.5 Updating Standards:**
- 4.5.1 Standards referenced in the I-Codes:** The updating of standards referenced by the Codes shall be accomplished administratively by the Administrative code development committee in accordance with these full procedures except that the deadline for availability of the updated standard and receipt by the Secretariat shall be December 1 of the third year of each code cycle. The published version of the new edition of the Code which references the standard will refer to the updated edition of the standard. If the standard is not available by the deadline, the edition of the standard as referenced by the newly published Code shall revert back to the reference contained in the previous edition and an errata to the Code issued Multiple standards to be updated may be included in a single proposal.
- 4.6 Preparation:** All code change proposals in compliance with these procedures shall be prepared in a standard manner by the Secretariat and be assigned separate, distinct and consecutive numbers. The Secretariat shall coordinate related proposals submitted in accordance with Section 3.3.2 to facilitate the hearing process.
- 4.7 Publication:** All code change proposals shall be posted on the ICC website at least 30 days prior to the public hearing on those proposals and shall constitute the agenda for the public hearing. Code

change proposals which have not been published shall not be considered.

5.0 Public Hearing

- 5.1 Intent:** The intent of the public hearing is to permit interested parties to present their views including the cost and benefits on the code change proposals on the published agenda. The code development committee will consider such comments as may be presented in the development of their action on the disposition of such proposals. At the conclusion of the code development committee deliberations, the committee action on each code change proposal shall be placed before the hearing assembly for consideration in accordance with Section 5.7.
- 5.2 Committee:** The Code Development Committees shall be appointed by the Board of Directors.
- 5.2.1 Chairman/Moderator:** The Chairman and Vice-Chairman shall be appointed by the Steering Committee on Councils from the appointed members of the committee. The ICC President shall appoint one or more Moderators who shall act as presiding officer for the public hearing.
- 5.2.2 Conflict of Interest:** A committee member shall withdraw from and take no part in those matters with which the committee member has an undisclosed financial, business or property interest. The committee member shall not participate in any committee discussion on the matter or any committee vote. A committee member who is a proponent of a proposal shall not participate in any committee discussion on the matter or any committee vote. Such committee member shall be permitted to participate in the floor discussion in accordance with Section 5.5 by stepping down from the dais.
- 5.2.3 Representation of Interest:** Committee members shall not represent themselves as official or unofficial representatives of the ICC except at regularly convened meetings of the committee.
- 5.2.4 Committee Composition:** The committee may consist of representation from multiple interests. A minimum of thirty-three and one-third percent (33.3%) of the committee members shall be regulators.
- 5.3 Date and Location:** The date and location of each public hearing shall be announced not less than 60 days prior to the date of the public hearing.
- 5.4 General Procedures:** *The Robert's Rules of Order* shall be the formal procedure for the conduct of the public hearing except as a specific provision of these Rules of Procedure may otherwise dictate. A quorum shall consist of a majority of the voting members of the committee.
- 5.4.1 Chair Voting:** The Chairman of the committee shall vote only when the vote cast will break a tie vote of the committee.
- 5.4.2 Open Meetings:** Public hearings of the Code Development Committees are open meetings. Any interested person may attend and participate in the Floor Discussion and Assembly Consideration portions of the hearing. Only eligible voters (see Section 5.7.4) are permitted to vote on Assembly Considerations. Only Code Development Committee members may participate in the Committee Action portion of the hearings (see Section 5.6). Participants shall not advocate a position on specific code changes with Committee Members other than through the methods provided in this policy.
- 5.4.3 Presentation of Material at the Public Hearing:** Information to be provided at the hearing shall be limited to verbal presentations and modifications submitted in accordance with Section 5.5.2. Each individual presenting information at the hearing shall state their name and affiliation, and shall identify any entities or individuals they are representing in connection with their testimony. Audio-visual presentations are not permitted. Substantiating material submitted in accordance with Section 3.3.4.4 and other material submitted in response to a code change proposal shall be located in a designated area in the hearing room and shall not be distributed to the code development committee at the public hearing.
- 5.4.4 Agenda Order:** The Secretariat shall publish an agenda for each public hearing, placing individual code change proposals in a logical order to facilitate the hearing. Any public hearing attendee may move to revise the agenda order as the first order of business at the public

hearing, or at any time during the hearing except while another proposal is being discussed. Preference shall be given to grouping like subjects together, and for moving items back to a later position on the agenda as opposed to moving items forward to an earlier position. A motion to revise the agenda order is subject to a 2/3 vote of those present and voting.

5.4.5 Reconsideration: There shall be no reconsideration of a proposed code change after it has been voted on by the committee in accordance with Section 5.6; or, in the case of assembly consideration, there shall be no reconsideration of a proposed code change after it has been voted on by the assembly in accordance with Section 5.7.

5.4.6 Time Limits: Time limits shall be established as part of the agenda for testimony on all proposed changes at the beginning of each hearing session. Each person requesting to testify on a change shall be given equal time. In the interest of time and fairness to all hearing participants, the Moderator shall have limited authority to modify time limitations on debate. The Moderator shall have the authority to adjust time limits as necessary in order to complete the hearing agenda.

5.4.6.1 Time Keeping: Keeping of time for testimony by an individual shall be by an automatic timing device. Remaining time shall be evident to the person testifying. Interruptions during testimony shall not be tolerated. The Moderator shall maintain appropriate decorum during all testimony.

5.4.6.2 Proponent Testimony: The Proponent is permitted to waive an initial statement. The Proponent shall be permitted to have the amount of time that would have been allocated during the initial testimony period plus the amount of time that would be allocated for rebuttal. Where the code change proposal is submitted by multiple proponents, this provision shall permit only one proponent of the joint submittal to be allotted additional time for rebuttal.

5.4.7 Points of Order: Any person participating in the public hearing may challenge a procedural ruling of the Moderator or the Chairman. A majority vote of the eligible voters as determined in Section 5.7.4 shall determine the decision.

5.5 Floor Discussion: The Moderator shall place each code change proposal before the hearing for discussion by identifying the proposal and by regulating discussion as follows:

5.5.1 Discussion Order:

1. *Proponents.* The Moderator shall begin by asking the proponent and then others in support of the proposal for their comments.
2. *Opponents.* After discussion by those in support of a proposal, those opposed hereto, if any, shall have the opportunity to present their views.
3. *Rebuttal in support.* Proponents shall then have the opportunity to rebut points raised by the opponents.
4. *Re-rebuttal in opposition.* Opponents shall then have the opportunity to respond to the proponent's rebuttal.

5.5.2 Modifications: Modifications to proposals may be suggested from the floor by any person participating in the public hearing. The person proposing the modification is deemed to be the proponent of the modification.

5.5.2.1 Submission and Written Copies. All modifications must be written, unless determined by the Chairman to be either editorial or minor in nature. The modification proponent shall provide 20 copies to the Secretariat for distribution to the committee.

5.5.2.2 Criteria. The Chairman shall rule proposed modifications in or out of order before they are discussed on the floor. A proposed modification shall be ruled out of order if it:

1. is not legible, unless not required to be written in accordance with Section 5.5.2.1; or

2. changes the scope of the original proposal; or
3. is not readily understood to allow a proper assessment of its impact on the original proposal or the code.

The ruling of the Chairman on whether or not the modification is in or out of order shall be final and is not subject to a point of order in accordance with Section 5.4.7.

5.5.2.3 Testimony. When a modification is offered from the floor and ruled in order by the Chairman, a specific floor discussion on that modification is to commence in accordance with the procedures listed in Section 5.5.1.

5.6 Committee Action: Following the floor discussion of each code change proposal, one of the following motions shall be made and seconded by members of the committee.

1. Approve the code change proposal as submitted (AS) or
2. Approve the code change proposal as modified with specific modifications (AM), or
3. Disapprove the code change proposal (D)

Discussion on this motion shall be limited to Code Development Committee members. If a committee member proposes a modification which had not been proposed during floor discussion, the Chairman shall rule on the modification in accordance with Section 5.5.2.2 If a committee member raises a matter of issue, including a proposed modification, which has not been proposed or discussed during the floor discussion, the Moderator shall suspend the committee discussion and shall reopen the floor discussion for comments on the specific matter or issue. Upon receipt of all comments from the floor, the Moderator shall resume committee discussion.

The Code Development Committee shall vote on each motion with the majority dictating the committee's action. Committee action on each code change proposal shall be completed when one of the motions noted above has been approved. Each committee vote shall be supported by a reason.

The Code Development Committee shall maintain a record of its proceedings including the action on each code change proposal.

5.7 Assembly Consideration: At the conclusion of the committee's action on a code change proposal and before the next code change proposal is called to the floor, the Moderator shall ask for a motion from the public hearing attendees who may object to the committee's action. If a motion in accordance with Section 5.7.1 is not brought forward on the committee's action, the results of the public hearing shall be established by the committee's action. If a motion in accordance with Section 5.7.1 is brought forward and is sustained in accordance with Section 5.7.3, both the committee's action and the assemblies' action shall be reported as the results of the public hearing.

5.7.1 Floor Motion: Any attendee may raise an objection to the committee's action in which case the attendee will be able to make a motion to:

1. Approve the code change proposal as submitted from the floor (ASF), or
2. Approve the code change proposal as modified from the floor (AMF) with a specific modification that has been previously offered from the floor and ruled in order by the Chairman during floor discussion (see Section 5.5.2) or has been offered by a member of the Committee and ruled in order by the Chairman during committee discussion (see Section 5.6), or
3. Disapprove the code change proposal from the floor (DF).

5.7.2 Discussion: On receipt of a second to the floor motion, the Moderator shall place the motion before the assembly for a vote. No additional testimony shall be permitted.

5.7.3 Assembly Action: A successful assembly action shall be a majority vote of the votes cast by eligible voters (See 5.7.4).

5.7.4 Eligible Voters: All members of ICC in attendance at the public hearing shall be eligible to vote on floor motions. Each member is entitled to one vote, except that each Governmental Member Voting Representative in attendance may vote on behalf of its Governmental Member. Code Development Committee members shall be eligible to vote on floor motions. Application, whether

new or updated, for ICC membership must be received by the Code Council ten days prior to the commencement of the first day of the public hearing.

- 5.8 Report of the Public Hearing:** The results of the public hearing, including committee action and successful assembly action, shall be posted on the ICC website not less than 60 days prior to Final Action Consideration except as approved by the ICC Board.

6.0 Public Comments

- 6.1 Intent:** The public comment process gives attendees at the Final Action Hearing an opportunity to consider specific objections to the results of the public hearing and more thoughtfully prepare for the discussion for Final Action Consideration. The public comment process expedites the Final Action Consideration at the Final Action Hearing by limiting the items discussed to the following:

6.1.1 Consideration of items for which a public comment has been submitted; and

6.1.2 Consideration of items which received a successful assembly action at the public hearing.

- 6.2 Deadline:** The deadline for receipt of a public comment to the results of the public hearing shall be announced at the public hearing but shall not be less than 30 days from the availability of the report of the results of the public hearing (see Section 5.8).

- 6.3 Withdrawal of Public Comment:** A public comment may be withdrawn by the public commenter at any time prior to Final Action Consideration of that comment. A withdrawn public comment shall not be subject to Final Action Consideration. If the only public comment to a code change proposal is withdrawn by the public commenter prior to the vote on the consent agenda in accordance with Section 7.3.4, the proposal shall be considered as part of the consent agenda. If the only public comment to a code change proposal is withdrawn by the public commenter after the vote on the consent agenda in accordance with Section 7.3.4, the proposal shall continue as part of the individual consent agenda in accordance with Section 7.3.5, however the public comment shall not be subject to Final Action Consideration.

- 6.4 Form and Content of Public Comments:** Any interested person, persons, or group may submit a public comment to the results of the public hearing which will be considered when in conformance to these requirements. Each public comment to a code change proposal shall be submitted separately and shall be complete in itself. Each public comment shall contain the following information:

6.4.1 Public comment: Each public comment shall include the name, title, mailing address, telephone number and email address of the public commenter. Email addresses shall be published with the public comments unless the commenter otherwise requests on submittal form. If group, organization, or committee submits a public comment, an individual with prime responsibility shall be indicated. If a public comment is submitted on behalf a client, group, organization or committee, the name and mailing address of the client, group, organization or committee shall be indicated. The scope of the public comment shall be consistent with the scope of the original code change proposal, committee action or successful assembly action. Public comments which are determined as not within the scope of the code change proposal, committee action or successful assembly action shall be identified as such. The public commenter shall be notified that the public comment is considered an incomplete public comment in accordance with Section 6.5.1 and the public comment shall be held until the deficiencies are corrected. A copyright release in accordance with Section 3.3.4.5 shall be provided with the public comment.

6.4.2 Code Reference: Each public comment shall include the code change proposal number and the results of the public hearing, including successful assembly actions, on the code change proposal to which the public comment is directed.

6.4.3 Multiple public comments to a code change proposal. A proponent shall not submit multiple public comments to the same code change proposal. When a proponent submits multiple public comments to the same code change proposal, the public comments shall be considered as incomplete public comments and processed in accordance with Section 6.5.1. This restriction shall not apply to public comments that attempt to address differing subject matter within a code section.

6.4.4 Desired Final Action: The public comment shall indicate the desired final action as one of the following:

1. Approve the code change proposal as submitted (AS), or
2. Approve the code change proposal as modified (AM) by one or more specific modifications published in the Results of the Public Hearing or published in a public comment, or
3. Disapprove the code change proposal (D)

6.4.5 Supporting Information: The public comment shall include in a statement containing a reason and justification for the desired final action on the code change proposal. Reasons and justification which are reviewed in accordance with Section 6.4 and determined as not germane to the technical issues addressed in the code change proposal or committee action may be identified as such. The public commenter shall be notified that the public comment is considered an incomplete public comment in accordance with Section 6.5.1 and the public comment shall be held until the deficiencies are corrected. The public commenter shall have the right to appeal this action in accordance with the policy of the ICC Board. A bibliography of any substantiating material submitted with a public comment shall be published with the public comment and the substantiating material shall be made available at the Final Action Hearing. All substantiating material published by ICC is material that has been provided by the proponent and in so publishing ICC makes no representations or warranties about its quality or accuracy.

6.4.6 Number: One copy of each public comment and one copy of all substantiating information shall be submitted. Additional copies may be requested when determined necessary by the Secretariat. A copy of the public comment in electronic form is preferred.

6.5 Review: The Secretariat shall be responsible for reviewing all submitted public comments from an editorial and technical viewpoint similar to the review of code change proposals (See Section 4.2).

6.5.1 Incomplete Public Comment: When a public comment is submitted with incorrect format, without the required information or judged as not in compliance with these Rules of Procedure, the public comment shall not be processed. The Secretariat shall notify the public commenter of the specific deficiencies and the public comment shall be held until the deficiencies are corrected, or the public comment shall be returned to the public commenter with instructions to correct the deficiencies with a final date set for receipt of the corrected public comment.

6.5.2 Duplications: On receipt of duplicate or parallel public comments, the Secretariat may consolidate such public comments for Final Action Consideration. Each public commenter shall be notified of this action when it occurs.

6.5.3 Deadline: Public comments received by the Secretariat after the deadline set for receipt shall not be published and shall not be considered as part of the Final Action Consideration.

6.6 Publication: The public hearing results on code change proposals that have not been public commented and the code change proposals with public commented public hearing results and successful assembly actions shall constitute the Final Action Agenda. The Final Action Agenda shall be posted on the ICC website at least 30 days prior to Final Action consideration.

7.0 Final Action Consideration

7.1 Intent: The purpose of Final Action Consideration is to make a final determination of all code change proposals which have been considered in a code development cycle by a vote cast by eligible voters (see Section 7.4).

7.2 Agenda: The final action consent agenda shall be comprised of proposals which have neither an assembly action nor public comment. The agenda for public testimony and individual consideration shall be comprised of proposals which have a successful assembly action or public comment (see Sections 5.7 and 6.0).

7.3 Procedure: *The Robert's Rules of Order* shall be the formal procedure for the conduct of the Final Action Consideration except as these Rules of Procedure may otherwise dictate.

7.3.1 Open Meetings: Public hearings for Final Action Consideration are open meetings. Any

interested person may attend and participate in the Floor Discussion.

- 7.3.2 Agenda Order:** The Secretariat shall publish an agenda for Final Action Consideration, placing individual code change proposals and public comments in a logical order to facilitate the hearing. The proponents or opponents of any proposal or public comment may move to revise the agenda order as the first order of business at the public hearing, or at any time during the hearing except while another proposal is being discussed. Preference shall be given to grouping like subjects together and for moving items back to a later position on the agenda as opposed to moving items forward to an earlier position. A motion to revise the agenda order is subject to a 2/3 vote of those present and voting.
- 7.3.3 Presentation of Material at the Public Hearing:** Information to be provided at the hearing shall be limited to verbal presentations. Each individual presenting information at the hearing shall state their name and affiliation, and shall identify any entities or individuals they are representing in connection with their testimony. Audio-visual presentations are not permitted. Substantiating material submitted in accordance with Section 6.4.4 and other material submitted in response to a code change proposal or public comment shall be located in a designated area in the hearing room.
- 7.3.4 Final Action Consent Agenda:** The final action consent agenda (see Section 7.2) shall be placed before the assembly with a single motion for final action in accordance with the results of the public hearing. When the motion has been seconded, the vote shall be taken with no testimony being allowed. A simple majority (50% plus one) based on the number of votes cast by eligible voters shall decide the motion.
- 7.3.5 Individual Consideration Agenda:** Upon completion of the final action consent vote, all proposed changes not on the final action consent agenda shall be placed before the assembly for individual consideration of each item (see Section 7.2).
- 7.3.6 Reconsideration:** There shall be no reconsideration of a proposed code change after it has been voted on in accordance with Section 7.3.8.
- 7.3.7 Time Limits:** Time limits shall be established as part of the agenda for testimony on all proposed changes at the beginning of each hearing session. Each person requesting to testify on a change shall be given equal time. In the interest of time and fairness to all hearing participants, the Moderator shall have limited authority to modify time limitations on debate. The Moderator shall have the authority to adjust time limits as necessary in order to complete the hearing agenda.
- 7.3.7.1 Time Keeping:** Keeping of time for testimony by an individual shall be by an automatic timing device. Remaining time shall be evident to the person testifying. Interruptions during testimony shall not be tolerated. The Moderator shall maintain appropriate decorum during all testimony.
- 7.3.8 Discussion and Voting:** Discussion and voting on proposals being individually considered shall be in accordance with the following procedures:
- 7.3.8.1 Allowable Final Action Motions:** The only allowable motions for final action are Approval as Submitted, Approval as Modified by one or more modifications published in the Final Action Agenda, and Disapproval.
- 7.3.8.2 Initial Motion:** The Code Development Committee action shall be the initial motion considered.
- 7.3.8.3 Motions for Modifications:** Whenever a motion under consideration is for Approval as Submitted or Approval as Modified, a subsequent motion and second for a modification published in the Final Action Agenda may be made (see Section 6.4.3). Each subsequent motion for modification, if any, shall be individually discussed and voted before returning to the main motion. A two-thirds majority based on the number of votes cast by eligible voters shall be required for a successful motion on all modifications.
- 7.3.8.4 Voting:** After dispensing with all motions for modifications, if any, and upon

completion of discussion on the main motion, the Moderator shall then ask for the vote on the main motion. If the motion fails to receive the majority required in Section 7.5, the Moderator shall ask for a new motion.

7.3.8.5 Subsequent Motion: If the initial motion is unsuccessful, a motion for one of the other allowable final actions shall be made (see Section 7.3.8.1) and dispensed with until a successful final action is achieved. If a successful final action is not achieved, Section 7.5.1 shall apply.

7.3.9 Proponent testimony: The Proponent of a public comment is permitted to waive an initial statement. The Proponent of the public comment shall be permitted to have the amount of time that would have been allocated during the initial testimony period plus the amount of time that would be allocated for rebuttal. Where a public comment is submitted by multiple proponents, this provision shall permit only one proponent of the joint submittal to waive an initial statement.

7.3.10 Points of Order: Any person participating in the public hearing may challenge a procedural ruling of the Moderator. A majority vote of the eligible voters as determined in Section 5.7.4 shall determine the decision.

7.4 Eligible voters: ICC Governmental Member Representatives and Honorary Members in attendance at the Final Action Hearing shall have one vote per eligible attendee on all International Codes.

Applications for Governmental Membership must be received by the ICC by April 1st of the applicable year in order for its designated representatives to be eligible to vote at the Final Action Hearing. Applications, whether new or updated, for governmental member voting representative status must be received by the Code Council thirty (30) days prior to the commencement of the first day of the Final Action Hearing in order for any designated representative to be eligible to vote. An individual designated as a Governmental Member Voting Representative shall provide sufficient information to establish eligibility as defined in the ICC Bylaws. The Executive Committee of the ICC Board, in its discretion, shall have the authority to address questions related to eligibility. Decisions of the Executive Committee shall be final and not appealable pursuant to CP 1, other than claims of fraud or misrepresentation, supported by reasonably credible evidence, that were material to the outcome of the Final Action Hearing.

7.5 Majorities for Final Action: The required voting majority based on the number of votes cast of eligible voters shall be in accordance with the following table:

Committee Action (see note)	Desired Final Action		
	AS	AM	D
AS	Simple Majority	2/3 Majority	Simple Majority
AM	2/3 Majority	Simple Majority to sustain the Public Hearing Action or; 2/3 Majority on additional modifications and 2/3 on overall AM	Simple Majority
D	2/3 Majority	2/3 Majority	Simple Majority

7.5.1 Failure to Achieve Majority Vote: In the event that a code change proposal does not receive any of the required majorities for final action in Section 7.5, final action on the code change proposal in question shall be disapproval.

7.6 Publication: The Final action on all proposed code changes shall be published as soon as practicable after the determination of final action. The exact wording of any resulting text modifications shall be made available to any interested party.

8.0 Appeals

8.1 Right to Appeal: Any person may appeal an action or inaction in accordance with CP-1.

2012 ICC CODE DEVELOPMENT CYCLE CROSS INDEX OF PROPOSED CODE CHANGES

Some of the proposed code changes include sections that are outside of the scope of the chapters or the code listed in the table of 2012/2013 Staff Secretaries on page x. This is done in order to facilitate coordination among the International Codes which is one of the fundamental principles of the International Codes.

Listed in this cross index are proposed code changes that include sections of codes or codes other than those listed on page ix. For example, IBC Section 703.2.3 is proposed for revision in code change S70-12, which is to be heard by the IBC Structural Committee. This section of the IBC is typically the responsibility of the IBC Fire Safety Committee as listed in the table of 2012/2013 Staff Secretaries. It is therefore identified in this cross index. Another example is Section 905.4 of the International Fire Code. The International Fire Code is normally maintained by the IFC Committee, but Section 905.4 will be considered for revision in proposed code change E4-12 which will be placed on the IBC Means of Egress Committee agenda. In some instances, there are other subsections that are revised by an identified code change that is not included in the cross index. For example, numerous sections in Chapter 10 of the International Fire Code would be revised by the proposed changes to Chapter 10 of the IBC. This was done to keep the cross index brief enough for easy reference.

This information is provided to assist users in locating all of the proposed code changes that would affect a certain section or chapter. For example, to find all of the proposed code changes that would affect Chapter 7 of the IBC, review the proposed code changes in the portion of the monograph for the IBC Fire Safety Committee (listed with a FS prefix) then review this cross reference for Chapter 7 of the IBC for proposed code changes published in other code change groups. While care has been taken to be accurate, there may be some omissions in this list.

Letter prefix: Each proposed change number has a letter prefix that will identify where the proposal is published. The letter designations for proposed changes and the corresponding publications are as follows:

PREFIX	PROPOSED CHANGE GROUP (see monograph table of contents for location)
ADM	Administrative
E	International Building Code - Means of Egress
EB	International Existing Building Code
CE	International Energy Conservation Code – Commercial
RE	International Energy Conservation Code – Energy
F	International Fire Code
FG	International Fuel Gas Code
FS	International Building Code - Fire Safety
G	International Building Code – General
GEW	International Green Construction Code – Energy/Water
GG	International Green Construction Code – General
M	International Mechanical Code
PC	ICC Performance Code
P	International Plumbing Code
PSD	International Private Sewage Disposal Code
PM	International Property Maintenance Code
RE	International Residential Code - Building
RM	International Residential Code - Mechanical
RP	International Residential Code - Plumbing
S	International Building Code – Structural
SP	International Swimming Pool and Spa Code
WUIC	International Wildland-Urban Interface Code
Z	International Zoning Code

International Building Code		907.2.10.1	G71
		907.2.13.2	E4
101.4	G201	907.5.2.2	E4
101.4.7 (New)	G201	909.4.6	G32 Part II
104.11.3 (New)	FS73	909.9	S70
107.2.6	G198	909.18	S113, S117
110.3.5	S304	909.20	E4, E5
116.5	G201	909.21.7	S113
202	P27, P29	911.1.5	E4
403.5	E4, E7	1003.2	G62
404.6	FS41, FS99	Table 1004.1.2	G193
405.7.1	E3	1004.3	S90
410.6.1	E3	1005.7.2	G73
411.7	E3	1007.1	G237
414.7.2	E3	1007.6	G57
505.2.3	E7	1009.3	FS51, FS99
505.3	E101	1015.2.1	G85
703.2.3	S70	1015.4	G57
706.1	G103	1015.5	G57
707.5.1	E7	Table 1016.2	G32 Part I, G87
707.6	E4	1018.1	G31 Part I
707.7.1	E4	Table 1018.1	G32 Part I
709.5	G31 Part I	Table 1018.2	G32 part I
710.8	G32 Part I	1018.4	G32 Part I
711.4	E7	Table 1021.2(2)	G57
712.1.8	G32 Part I, G54, E7	1022.7	G85
712.1.12	E7	1027.1	G175
713.1	E4, E7	1203.1	M36, M37, M38, M39
713.14.1	G32 Part I, E110	1205.4	E4
713.14.1.2 (new)	G174 Part III	1207.1	E4
Table 716.5	G51, E4	1403.7	S102, S103
716.5.3	E3	1404.13 (New)	S309
717.5.5	G32 Part I	1507.16	G98
718.2.4	E4	1507.16.1	G98
722.5	S238	1508.1	FS178
Table 803.9	E4	1609.1.2	G199
901.5	S90	1808.7.3	G193
903.2.6	G31 Part II, G32 Part II	2103.15(New)	FS177
903.2.8	G31 Part II	2110.1.1	E4
903.2.8.1	G31 Part II	2303.1.4 (new)	G142 Part II
903.2.8.2 (new)	G31 Part II	2308.12.7	E4
903.2.8.2	G31 Part II	2405.3	G199
903.2.8.3 (new)	G31 Part II	2406.4	G193
903.3.1.3	G31 Part II	2406.4.5	G193
903.3.2	G32 Part II	2406.4.6	E4
905.3.3	E4	2406.4.7	E4
905.4	E4	2607.4	G199
906.2	G71	2609.4	G193, G199
Table 906.3(1)	G71	Table 2902.1.2 (New)	P27
Table 906.3(2)	G71	2902.2	P34
907.2.6	G32 Part II, G71	2902.3	P35
907.2.6.1	G31 Part II	2902.3.1	P36
907.2.6.4 (new)	G32 Part II	2902.3.5	P37

International Building Code (continued)		1003.2	G62
		Table 1004.1.2	G193
2902.4.1	P39	1005.7.2	G73
2902.6 (New)	P30	1007.1	G237
Table 2902.1.2 (New)	P27	1007.6	G57
3007.7	E110	1015.2.1	G85
3007.9	FS138	1015.4	G57
3008.7	E110	1015.5	G57
3008.9	FS138	Table 1016.2	G32 Part I, G87
3111.1	S3	1018.1	G31 Part I
3306.8	S90	Table 1018.1	G32 Part I
3311.1	E4	Table 1018.2	G32 part I
3401.2	S90	1018.4	G32 Part I
3406.1.3	E4	Table 1021.2(2)	G57
3406.4	E4	1022.7	G85
3411.8.4	E4	1027.1	G175
3411.8.15	E211	1104.6.1	E4
International Fire Code		1104.9	E4
		1104.10	E4
202	G1, G2, G11, G13, G31 Part I, G32 Part I, G43, G70	1104.12	E4
Definition of Group A	G27	1104.16	E4
Definition of Group B	G28, G29, G30	1104.20	E4
Definition of Group E	G27	1104.21	E4
Definition of Group I	G31 Part I, G32 Part I, G33, G34, G35, G36, G37	1104.23	E4
Definition of Group R	G31 Part I, G34, G36, G38, G39, G40, G41	3313.1	E4
Definition of Group S	G42	5005.4.4	E3
508.1.5	E4	5704.2.9.4	E4
604.2.16 (new)	G77	5706.5.1.12	E4
903.2.6	G31 Part II, G32 Part II	INTERNATIONAL PLUMBING CODE	
903.2.8	G31 Part II		
903.2.8.1	G31 Part II	202	G8, G193 Part IV, P3(HEARD BY IBC-S)
903.2.8.2 (new)	G31 Part II	309.2	P20 (HEARD BY IBC-S)
903.2.8.2	G31 Part II	403.3.3	G71
905.3.3	E4	403.3.4	G71
905.4	E4	403.5	G71
903.2.8.3 (new)	G31 Part II	423.1	G193 Part IV
903.3.1.3	G31 Part II	612.1	G193 Part IV
903.3.2	G32 Part II	801.1	G193 Part IV
906.2	G71	802.1.4	G193 Part IV
Table 906.3(1)	G71	INTERNATIONAL MECHANICAL CODE	
Table 906.3(2)	G71		
907.2.6	G32 Part II, G71	202	G8
907.2.6.1	G31 Part II	304.11	E108
907.2.6.4 (new)	G32 Part II	306.5.1	E4
907.2.10.1	G71	403.2.1	G193 Part II
907.2.13.2	E4	Table 403.3	G193 Part II
907.5.2.2	E4	601.3	E228, E229
909.4.6	G32 Part II	901.5	FG3

INTERNATIONAL MECHANICAL CODE (continued)		406.1	G225, G226
		410.5.1(new)	G235
901.6	FG3	410.6	G235, G236, G237
926.2	FG38	410.7	G237, G238, G240
926.3	FG38	410.7.1	G240
1107.2	E4	410.8	G239, E211
1401.1	G193 Part II	410.8 (new)	G237
INTERNATIONAL FUEL GAS CODE		410.8.1 (new)	G237
		410.8.4	G241
202	G8	410.8.6	G242
306.5.1	E4	410.8.9	G235, G236
614.6	M71	410.8.11	G243
Section 617	G193 Part III	606.2.2	G221 Part II
617.1	G193 Part III	606.2.3.1	G224 Part II
629.1	M169	907.2	G213 Part II
INTERNATIONAL PRIVATE SEWAGE DISPOSAL CODE		907.2.1	G213 Part II
		907.2.2	G213 Part II
		1401.2	G244
202	G8, P228 (HEARD BY IBC-S)	1401.2.5	G245
401.3.2	G193 Part IV	1401.3.2	G246
Table 406.1	G193 Part IV	Table 1401.3.2(new)	G246
Table 604.1(2)	G193 Part IV	1401.6	G244
Table 802.7.2	G193 Part IV	1401.6.1	G101
Table 802.8	G193 Part IV	1401.6.1.1	G101
INTERNATIONAL EXISTING BUILDING CODE		1401.6.2	G101, G244
		1401.6.2.1	G101
Chapters 3 through 14	G205	1401.6.4	G244
202	G23, G24	Table 1401.6.4	G244
402.1	G210	1401.6.5	G244
402.4	G211	Table 1401.6.5	G57, G244
403.1	G210, G212	1401.6.6	G51
403.3 (new)	G213 Part I	1401.6.7	G244
403.3.1 (new)	G213 Part I	1401.6.8	G244
403.3.2 (new)	G213 Part I	Table 1401.6.8	G244
403.3.3 (new)	G213 Part I	1401.6.8.1	G244
403.4	G211	1401.6.9	G244
403.4.1(new)	G214	Table 1401.6.9	G244
403.4.5 (new)	G215, G216, G217	1401.6.10	G244
403.5 (new)	G218	Table 1401.6.10	G244
403.7 (new)	G219	1401.6.11	G244
403.7.1(new)	G219	Table 1401.6.11	G244
403.7.2(new)	G219	1401.6.12	G244
403.7.3(new)	G219	Table 1401.6.12	G244
404.1	G212	1401.6.12.1	G244
404.2 (new)	G220	1401.6.16	G244
404.2	G221 Part I	1401.6.16.1	G244
404.2.1	G211	1401.6.17	G244
404.2.2	G222	Table 1401.6.17	G244
404.3	G223	1401.6.18	G244
404.3.1	G224 Part I	Table 1401.6.18	G244
404.4	G222	1401.6.20 (new)	G244
404.2.3	G211, G212	Table 1401.6.20 (new)	G244
404.5	G212	1401.6.21 (new)	G244

**INTERNATIONAL EXISTING BUILDING CODE
(continued)**

Table 1401.6.21.1 (new)	G244
1401.6.21.1.1(new)	G244
1401.6.21.2(new)	G244
Table 1401.6.21.2(new)	G244
1401.6.21.2.1(new)	G244
1401.6.21.3(new)	G244
Table 1401.6.21.3	G244
1401.6.21.3.1(new)	G244
Table 1401.7	G244
1401.8	G244
Table 1401.8	G244

2012 GROUP A CODE DEVELOPMENT HEARING SCHEDULE

April 29 – May 8, 2012

Sheraton Dallas Hotel

Unless noted by “Start no earlier than X am,” each Code Committee will begin immediately upon completion of the hearings for the prior Committee. Thus the actual start times for the various Code Committees are tentative. The hearing volume is higher than previous cycles. The schedule anticipates that the hearings will finish by the times noted as “Finish” for each track.

Please note that the hearing start on Sunday, April 29th has been revised from 10:00 am to 12:00 pm from the originally posted version. Prior to the hearings starting at noon on Sunday, the following is also scheduled:

- Membership Councils: 8:00 am – 10:00 am
- CDP ACCESS update (Expanding code development participation): 10:15 am – 11:15 am

For more information on the scheduling of these two activities, be sure to check the link to the Member Committees page on the ICC Website: <http://www.iccsafe.org/membership/pages/committees.aspx>

	Sunday April 29	Monday April 30	Tuesday May 1	Wednesday May 2	Thursday May 3
TRACK 1	Start 12 pm IBC - FS End 9 pm	Start 8 am IBC - FS End 9 pm	Start 8 am IBC - FS IBC - G (Start no earlier than 8 am) End 9 pm	Start 8 am IBC - G End 9 pm	Start 8 am IBC - G IBC - E (Start no earlier than 8 am) End 9 pm
TRACK 2	Start 12 pm IFGC IPC/IPSDC End 9 pm	Start 8 am IPC/IPSDC End 9 pm	Start 8 am IPC/IPSDC IMC (Start no earlier than 8 am) End 9 pm	Start 8 am IMC End 9 pm	Start 8 am IMC IEBC - S (Start no earlier than 8 am) IBC - S End 9 pm

	Friday May 4	Saturday May 5	Sunday May 6	Monday May 7	Tuesday May 8
TRACK 1	Start 8 am IBC - E End 9 pm	Start 8 am IBC - E End 9 pm	Start 8 am IBC - E Finish 12 pm		
TRACK 2	Start 8 am IBC - S End 9 pm	Start 8 am IBC - S End 9 pm	Start 8 am IBC - S End 9 pm	Start 8 am IBC - S End 9 pm	Start 8 am IBC - S Finish 12 pm

Notes:

1. IEBC - S: Structural provisions in the IEBC to be heard by the IBC - Structural Code Committee.
2. Hearing times may be modified at the discretion of the Chairman.
3. Breaks will be announced. Lunch and dinner breaks planned for each track. There will not be a lunch break on Sunday, April 29th.

**2012 PROPOSED CHANGES TO
THE INTERNATIONAL CODES**

<u>CODE</u>	<u>PAGE</u>
International Building Code	
Fire Safety	FS1
General	G1
Means of Egress	E1
Structural (Including portions of International Existing Building Code).....	S1
 International Fuel Gas Code	 FG1
 International Plumbing Code	 P1
 International Mechanical Code	 M1
 Code Correlation Committee	 CCC1

2012 PROPOSED CHANGES TO THE INTERNATIONAL BUILDING CODE – FIRE SAFETY

FIRE SAFETY CODE COMMITTEE

Kenneth E. Bush - Chair

Rep: National Association of State Fire Marshals
Senior Fire Protection Engineer
Maryland State Fire Marshal's Office
Easton, MD

Lorin Neyer – Vice Chair

Regional Compliance Officer
State of California – Office of Statewide Health,
Planning & Development
Manteca, CA

Gene Boecker, AIA

Senior Project Consultant
Code Consultants, Inc.
Saint Louis, MO

Matthew Dobson

Rep: National Association of Home Builders
Director
Vinyl Siding Institute
Burlington, NC

Douglas H. Evans, PE

Fire Protection Engineer
Clark County Department of Development
Services-Building Division
Las Vegas, NV

Wayne G. Hamilton

Rep: International Association of Fire Chiefs
Fire Marshal
City of Asheville Fire Department
Asheville, NC

Stephan Kiefer

Chief Building Official
City of Livermore
Livermore, CA

Bill McHugh

Executive Director
Firestop Contractors International Association
Hillside, IL

Bob D. Morgan, PE, CPCU

Senior Fire Protection Engineer
Fort Worth Fire Department
Fort Worth, TX

Timothy Pate, CBO

Acting Chief Building Official
City & County of Broomfield Building Division
Broomfield, CO

Michael Pokorny, PE

Fire Protection Engineer
Montgomery County Department of Permitting
Services
Rockville, MD

Michael Shannon, PE, CBO

Development Services Engineer
City of San Antonio, Development Svcs. Dept.
San Antonio, TX

David P. Tyree, PE, CBO

Director of Codes and Standards
Building Owners and Managers Association
Washington, DC

Michael E. Whalen

Construction Official
New Jersey Department of Community Affairs
Trenton, NJ

Terry Vosler

Senior Inspector
Bureau Veritas North America, Power and Utilities
Division
Henderson, NV

Staff Secretariat

Ed Wirtschoreck, LA

Manager, Standards
International Code Council
Country Club Hills, IL

TENTATIVE ORDER OF DISCUSSION 2012 PROPOSED CHANGES TO THE INTERNATIONAL BUILDING CODE

FIRE SAFETY

The following is the tentative order in which the proposed changes to the code will be discussed at the public hearings. Proposed changes which impact the same subject have been grouped to permit consideration in consecutive changes.

Proposed change numbers that are indented are those which are being heard out of numerical order. Indentation **does not** necessarily indicate that one change is related to another. Proposed changes may be grouped for purposes of discussion at the hearing at the discretion of the chair. Note that some IBC-FS code change proposals may not be included on this list, as they are being heard by other committees. Please consult the Cross Index of Proposed Changes.

G6-12	FS26-12	FS54-12	FS72-12
G11-12	FS27-12	FS55-12	FS73-12
G18-12	FS28-12	FS56-12	FS74-12
FS1-12	FS29-12	FS57-12	FS75-12
FS2-12	FS30-12	FS58-12, Part I	FS76-12
FS3-12	FS31-12	FS58-12, Part II	G14-12
FS4-12	FS32-12	FS58-12, Part III	G15-12`
FS5-12	FS33-12	FS58-12, Part IV	FS77-12
FS6-12	FS34-12	FS58-12, Part V	FS78-12
FS7-12	FS35-12	FS59-12	FS79-12
FS8-12	FS36-12	FS135-12	FS80-12
FS9-12	FS37-12	FS136-12	FS81-12
FS10-12	FS38-12	FS137-12	FS82-12
FS11-12	FS39-12	FS139-12	FS83-12
FS12-12	FS40-12	FS142-12	FS84-12
FS13-12	FS41-12	FS60-12	FS85-12
FS14-12	FS42-12	FS61-12	FS86-12
FS15-12	FS43-12	FS62-12	FS87-12
FS16-12	FS44-12	FS63-12	FS88-12
FS17-12	FS45-12	FS64-12	FS89-12
FS18-12	FS46-12	FS65-12	FS90-12
FS19-12	FS47-12	FS68-12	FS91-12
FS20-12	FS48-12	FS66-12	FS92-12
FS21-12	FS49-12	FS67-12	FS93-12
FS22-12	FS50-12	FS69-12	FS94-12
FS23-12	FS51-12	FS70-12	FS95-12
FS24-12	FS52-12	FS71-12	FS96-12
FS25-12	FS53-12	G174-12, Part III	FS97-12

FS98-12	FS144-12	FS181-12
FS99-12, Part I	FS145-12	FS182-12
FS99-12, Part II	FS147-12	FS183-12
FS99-12, Part III	FS148-12	FS184-12
FS99-12, Part IV	FS149-12	FS185-12
FS99-12, Part V	FS150-12	FS186-12
FS100-12	FS151-12	FS187-12
FS101-12	FS152-12	FS188-12
FS102-12, Part I	FS153-12	FS189-12
FS102-12, Part II	FS154-12	FS190-12
FS103-12	FS155-12	FS191-12
FS109-12	FS156-12	FS196-12
M88-12	FS157-12	FS197-12
M91-12	S309-12	FS199-12
G5-12	FS158-12	FS200-12
FS104-12	FS159-12	
FS105-12	FS160-12	
FS106-12	FS161-12	
FS107-12	FS162-12	
FS108-12	FS163-12	
FS110-12	FS164-12	
FS111-12	FS165-12	
FS112-12	FS166-12	
FS113-12	FS167-12	
FS114-12	FS169-12	
FS115-12	FS170-12	
FS116-12	FS171-12	
FS117-12	FS172-12	
FS118-12	FS173-12	
FS119-12	FS174-12	
FS120-12	FS175-12	
FS121-12	FS176-12	
FS122-12	S19-12	
FS123-12	S20-12	
FS124-12	S21-12	
FS125-12	S22-12	
FS126-12	S23-12	
FS127-12	S24-12	
FS128-12	S49-12	
FS129-12	S50-12	
FS130-12	S51-12	
S315-12, Part II	S54-12	
S316-12, Part II	S55-12	
FS131-12	S56-12	
FS132-12	S57-12	
FS133-12	S58-12	
FS134-12	FS177-11	
FS140-12	FS178-12	
FS141-12	FS179-12	
FS143-12	FS180-12	

FS1 – 12

703.2

Proponent: Bob Eugene, representing Underwriters Laboratories (Robert.Eugene@ul.com)

Revise as follows:

703.2 Fire-resistance ratings. The fire-resistance rating of building elements, components or assemblies shall be determined in accordance with the test procedures set forth in ASTM E 119 or UL 263 or in accordance with Section 703.3. The fire-resistance rating of penetrations and fire-resistant joint systems shall be determined in accordance Sections 714 and 715 respectively. Where materials, systems or devices that have not been tested as part of a fire-resistance-rated assembly are incorporated into the building element, component or assembly, sufficient data shall be made available to the building official to show that the required fire-resistance rating is not reduced. ~~Materials and methods of construction used to protect joints and penetrations in fire-resistance-rated building elements, components or assemblies shall not reduce the required fire-resistance rating.~~

Exception: In determining the fire-resistance rating of exterior bearing walls, compliance with the ASTM E 119 or UL 263 criteria for unexposed surface temperature rise and ignition of cotton waste due to passage of flame or gases is required only for a period of time corresponding to the required fire-resistance rating of an exterior nonbearing wall with the same fire separation distance, and in a building of the same group. When the fire-resistance rating determined in accordance with this exception exceeds the fire-resistance rating determined in accordance with ASTM E 119 or UL 263, the fire exposure time period, water pressure and application duration criteria for the hose stream test of ASTM E 119 or UL 263 shall be based upon the fire-resistance rating determined in accordance with this exception.

Reason: Section 703.2 currently covers four distinct concepts that are jumbled together in one section, which is confusing for the code user.

One of these concepts requires materials and methods of construction used to protect joints and penetrations in fire-resistance-rated building elements, components or assemblies to not reduce the required fire-resistance rating. Requirements covering joints and penetrations in sections 715 and 714, respectively, already address this concern. This proposal replaces this sentence with a new second sentence. The user is guided to Sections 714 and 715 for integrity of penetration firestops and joint systems.

Cost Impact: None

FS1-12

Public Hearing:	Committee:	AS	AM	D
	Assembly:	ASF	AMF	DF

703.2 #2-FS-EUGENE

FS2 – 12

703.2 (New), 703.3, 3102.3.1

Proponent: Bob Eugene, representing Underwriters Laboratories (Robert.Eugene@ul.com)

Revise as follows:

~~**703.2 Fire-resistance ratings.** The *fire-resistance rating* of building elements, components or assemblies shall be determined in accordance with the test procedures set forth in ASTM E 119 or UL 263 or in accordance with Section 703.3. Where materials, systems or devices that have not been tested as part of a fire-resistance-rated assembly are incorporated into the building element, component or assembly, sufficient data shall be made available to the *building official* to show that the required *fire-resistance rating* is not reduced. Materials and methods of construction used to protect joints and penetrations in fire-resistance-rated building elements, components or assemblies shall not reduce the required *fire-resistance rating*.~~

~~**Exception:** In determining the *fire-resistance rating* of exterior bearing walls, compliance with the ASTM E 119 or UL 263 criteria for unexposed surface temperature rise and ignition of cotton waste due to passage of flame or gases is required only for a period of time corresponding to the required *fire-resistance rating* of an exterior nonbearing wall with the same *fire-separation distance*, and in a building of the same group. When the *fire-resistance rating* determined in accordance with this exception exceeds the *fire-resistance rating* determined in accordance with ASTM E 119 or UL 263, the fire exposure time period, water pressure and application duration criteria for the hose stream test of ASTM E 119 or UL 263 shall be based upon the *fire-resistance rating* determined in accordance with this exception.~~

~~**703.3 Alternative methods for determining fire resistance.** **703.2 Fire-resistance ratings.** The application of any of the alternative methods listed in this section shall be based on the fire exposure and acceptance criteria specified in ASTM E 119 or UL 263. The fire-resistance rating of building elements, components or assemblies shall be determined in accordance with the test procedures set forth in ASTM E 119 or UL 263. The required fire resistance of a building element, component or assembly shall be permitted to be established by any of the following methods or procedures:~~

1. Fire-resistance designs documented in sources.
2. Prescriptive designs of fire-resistance-rated building elements, components or assemblies as prescribed in Section 721.
3. Calculations in accordance with Section 722.
4. Engineering analysis based on a comparison of building element, component or assemblies designs having fire-resistance ratings as determined by the test procedures set forth in ASTM E 119 or UL 263.
5. Alternative protection methods as allowed by Section 104.11.

(Sections 703.2.1 through 703.2.3 to remain unchanged)

(Renumber subsequent sections)

Reason: This proposal is intended to make the Section 703 requirements more user friendly. This proposal simply moves the requirements for determining fire resistance from section 703 to a more logical location in section 703.2. The resulting section now includes both the standards used to establish fire resistance ratings, and acceptable methods for establishing these ratings. It makes no changes to the five options in section 703.3, but does delete some duplicative wording.

The code currently indicates that Section 703.3 covers alternate methods for determining fire resistance. That is not really the case, what it really identifies are the acceptable methods for determining fire resistance, which are based on testing or determining equivalence to ASTM E119 and UL 263.

It is not the intent of this proposal to delete the remaining requirements in Section 703.2, but this proposal, as shown, assumes they have been relocated to other sections by our other proposals to Section 703.

Cost Impact: None

FS2-12

Public Hearing:	Committee:	AS	AM	D
	Assembly:	ASF	AMF	DF

703.2 #4-FS-EUGENE

FS3 – 12

703.2.3

Proponent: Tony Crimi, A.C. Consulting Solutions Inc, representing North American Insulation Manufacturers Association (NAIMA) (tcrimi@sympatico.ca)

Revise as follows:

703.2.3 Restrained classification. Fire-resistance-rated assemblies tested under ASTM E 119 or UL 263 shall not be considered to be restrained unless evidence satisfactory to the *building official* is furnished by the *registered design professional* showing that the construction qualifies for a restrained classification in accordance with ASTM E119 or UL 263. Where an assembly is deemed to be restrained, the rating of beams shall also have a restrained beam classification in accordance with ASTM E 119 or UL 263. Otherwise, fire-resistance rated assemblies shall be considered unrestrained. Restrained construction shall be identified on the plans.

Reason: The purpose of this proposal is to clarify that if an assembly is not considered to be restrained by the building official, it must be treated as an unrestrained assembly. A restrained classification yields higher fire-resistance ratings than unrestrained; therefore, the code takes the conservative approach by defaulting to the lesser rating by assuming the in-place conditions to be unrestrained unless structural documentation is provided that supports a restrained condition.

Because even restrained assembly ratings do not include restrained beams, the criteria for the beams used in restrained assemblies needs to comply with the restrained beam designs tested in order to comply with Table 601 of the IBC. The conditions of acceptance in ASTM E119 and ANSI/UL 263 provide criteria for Restrained Beam Ratings and Unrestrained Beam Ratings. A greater thickness of protection material is typically required for the Unrestrained Beam Rating as compared to the protection material thickness required for the Restrained Beam Rating based on the differences in the rating criteria. Accordingly, Unrestrained Beam Ratings may be used for beams designed for either restrained or unrestrained conditions. Restrained Beam Ratings may be used for beams designed for restrained conditions.

Floor-ceiling and roof-ceiling assemblies include fire-resistance ratings for use in both restrained or unrestrained conditions. It is up to the designer and Authority Having Jurisdiction to determine if an assembly is being used in a restrained or unrestrained application, as required by the IBC. Because of their more onerous criteria, Unrestrained Assembly Ratings may be used for floors and roofs designed for either restrained or unrestrained conditions.

Cost Impact: This proposal should not increase the cost of construction.

FS3-12

Public Hearing:	Committee:	AS	AM	D
	Assembly:	ASF	AMF	DF

703.2.3-FS-CRIMI

FS4 – 12

703.2.3

Proponent: Jerry R. Tepe, FAIA, JRT•AIA ARCHITECT representing The American Institute of Architects

Revise as follows:

703.2.3 Restrained classification. Fire-resistance-rated assemblies tested under ASTM E 119 or UL 263 shall not be considered to be restrained unless evidence satisfactory to the *building official* is furnished by the *registered design professional* showing that the construction qualifies for a restrained classification in accordance with ASTM E 119 or UL 263. Restrained construction shall be identified on the ~~plans~~ construction documents.

Reason: Revises the undefined term “plans” to the preferred and defined language of “construction documents.” There is no technical change proposed.

Cost Impact: None

FS4-12

Public Hearing:	Committee:	AS	AM	D
	Assembly:	ASF	AMF	DF

703.2.3-FS-TEPE

FS5 – 12

703.2.4 (New)

Proponent: Jason Thompson, National Concrete Masonry Association, representing Masonry Alliance for Codes and Standards

Add new text as follows:

703.2.4 Load-bearing wall assemblies. Fire-resistance-rated wall assemblies tested under ASTM E 119 or UL 263 shall not be considered to be load-bearing unless evidence satisfactory to the *building official* is furnished by the *registered design professional* showing that the construction qualifies as a load bearing element in accordance with ASTM E 119 or UL 263. The load-bearing fire-resistance-rated wall construction shall be identified on the plans.

Reason: Many times designers will submit wall assemblies to meet fire resistance requirements in the IBC without considering whether the assemblies were tested and passed ASTM E119 or UL 263 requirements as load-bearing. This proposal places this requirement in the code to make the code user aware of this important criterion for fire rated wall assemblies.

Cost Impact: This change should not increase the cost of construction.

FS5-12

Public Hearing:	Committee:	AS	AM	D
	Assembly:	ASF	AMF	DF

703.2.4 (NEW)-FS-THOMPSON

FS6 – 12

703.3

Proponent: Bob Eugene, representing Underwriters Laboratories (Robert.Eugene@ul.com)

Revise as follows:

703.3 Alternative methods for determining fire resistance. The application of any of the alternative methods listed in this section shall be based on the fire exposure and acceptance criteria specified in ASTM E 119 or UL 263. The required fire resistance of a building element, component or assembly shall be permitted to be established by any one of the following methods or procedures:

1. Fire-resistance designs ~~tested by an approved agency documented in sources.~~
2. Prescriptive designs ~~in accordance with of fire-resistance-rated building elements, components or assemblies as prescribed in Section 721.~~
3. Calculations in accordance with Section 722.
4. Engineering analysis based on a comparison of building element, component or assemblies designs having fire-resistance ratings as determined by the test procedures set forth in ASTM E 119 or UL 263.
5. Alternative protection methods as allowed by Section 104.11.

Reason: This proposal simplifies two of the options for establishing fire resistance. Concerning item 1, "Fire resistance designs in sources" could cover anything from a design from the UL Fire Resistance Directory to a sketch on a cocktail napkin. The intent appears to be designs tested to ASTM E119 or UL 263 by an approved agency, a defined term. The actual source of the design, whether in a publication or online, is irrelevant. The revision to item 2 is editorial only.

Cost Impact: None

FS6-12

Public Hearing:	Committee:	AS	AM	D
	Assembly:	ASF	AMF	DF

703.3 #1-FS-EUGENE

FS7 – 12

703.3, 722.6.2.4

Proponent: Bob Eugene, representing Underwriters Laboratories (Robert.Eugene@ul.com)

Revise as follows:

703.3 Alternative methods for determining fire resistance. The application of any of the alternative methods listed in this section shall be based on the fire exposure and acceptance criteria specified in ASTM E 119 or UL 263. The required fire resistance of a building element, component or assembly shall be established by any of the following methods or procedures:

1. Fire-resistance designs documented in sources.
2. Prescriptive designs of fire-resistance-rated building elements, components or assemblies as prescribed in Section 721.
3. Calculations in accordance with Section 722.
4. Engineering analysis based on a comparison of building element, component or assemblies designs having fire-resistance ratings as determined by the test procedures set forth in ASTM E 119 or UL 263.
5. ~~Alternative protection methods as allowed by Section 104.11.~~

722.6.2.4 Floors and roofs. In the case of a floor or roof, the standard test provides only for testing for fire exposure from below. ~~Except as noted in Section 703.3, Item 5, floor~~ Floor or roof assemblies of wood framing shall have an upper membrane consisting of a subfloor and finished floor conforming to Table 722.6.2(4) or any other membrane that has a contribution to fire resistance of at least 15 minutes in Table 722.6.2(1).

Reason: There is no need to make a specific reference to using alternate materials and methods in this section for two reasons. First, it is always an option that can be pursued. Second, that section provides no guidance whatsoever to the code users on how to determine an equivalent fire resistance rating. This section already includes options for using calculations or an engineering analysis for determining fire resistance. Section 703.3, item 5 does not appear to be a correct reference, since it includes no substantive requirements, but merely points to the section 104.11 alternate materials and methods provisions of the code. We could not identify a more appropriate section reference, so recommend this one be deleted with no substitution.

Cost Impact: None

FS7-12

Public Hearing:	Committee:	AS	AM	D
	Assembly:	ASF	AMF	DF

703.3 #2-FS-EUGENE AND 722.6.2.4-FS-EUGENE

FS8 – 12

703.4

Proponent: Joe Pierce, Dallas Fire Department, TX, representing the ICC Fire Code Action Committee

Delete without substitution:

~~**703.4 Automatic sprinklers.** Under the prescriptive fire resistance requirements of the International Building Code, the fire resistance rating of a building element, component or assembly shall be established without the use of automatic sprinklers or any other fire suppression system being incorporated as part of the assembly tested in accordance with the fire exposure, procedures, and acceptance criteria specified in ASTM E 119 or UL 263. However, this section shall not prohibit or limit the duties and powers of the building official allowed by Sections 104.10 and 104.11.~~

Reason: IBC Section 703.3 currently addresses alternative methods for determining fire resistance. Section 703.3 allows:

1. Prescriptive design according to Section 721
2. Engineering analysis based on ASTM E119 and UL 263 fire tests and reports
3. Alternative methods and materials according to Section 104.10

Section 703.4 specifies that sprinklers cannot be used as part of analyzing a fire-resistance requirement, but then it goes on to say that if you qualify the design under Section 104.10 as an alternate method then it is acceptable. Essentially, this section says “sprinklers cannot be included as providing any protection, but if you approve it under Section 104.10, then sprinklers can count.”

In essence, this section provides no guidance for either the designer or code official, and it is nearly redundant of the provisions found in Section 703.3.

This proposal will delete this section since it is not needed in the code.

Cost Impact: The code change will not increase the cost of construction.

FS8-12

Public Hearing:	Committee:	AS	AM	D
	Assembly:	ASF	AMF	DF

703.4-FS-PIERCE-FCAC

FS9 – 12

703.5

Proponent: Stephen V. Skalko, representing Portland Cement Association

Revise as follows:

703.5 Noncombustibility tests. The tests indicated in Sections 703.5.1 and 703.5.2 shall serve as criteria for acceptance of building materials as set forth in Sections 602.2 602.3 and 602.4 in Type I, II, III and IV construction. The term “noncombustible” does not apply to the flame spread characteristics of *interior finish* or *trim* materials. A material shall not be classified as a noncombustible building construction material if it is subject to an increase in combustibility or flame spread beyond the limitations herein established through the effects of age, moisture or other atmospheric conditions.

Exceptions:

1. Concrete and Concrete Products. Concrete and concrete products produced using aggregates conforming to ASTM C33, ASTM C330, ASTM C331 or ASTM C332 shall be considered non-combustible.
2. Clay Masonry. Clay masonry products permitted in TMS 402/ACI 530/ ASCE 5 shall be considered non-combustible.
3. Glass Masonry. Glass masonry products permitted in TMS 402/ACI 530/ ASCE 5 shall be considered non-combustible.
4. Steel. Steel conforming to the provisions in Chapter 22 of this code.

Add new standard to Chapter 35 as follows:

ASTM

C332-09 Standard Specification for Lightweight Aggregates for Insulating Concrete

Reason: In efforts to be green and sustainable traditional materials like concrete and concrete products are being made using a variety of substitute materials in the process. In addition, there is increased interest in disposing of materials within these newer types of traditional materials. One of the results of this movement is traditional materials (concrete, concrete masonry, clay masonry, glass, etc.) that have been considered non-combustible may no longer be non-combustible. This proposal establishes that traditional non-combustible materials conforming to the appropriate standards referenced in the International Building Code are considered non-combustible.

Cost Impact: This proposal will not increase the cost of construction

Analysis: A review of the standard proposed for inclusion in the code, ASTM C332 with regard to the ICC criteria for referenced standards (Section 3.6 of CP#28) will be posted on the ICC website on or before April 2, 2012.

FS9-12

Public Hearing:	Committee:	AS	AM	D
	Assembly:	ASF	AMF	DF

703.5-FS-SKALKO

FS10 – 12

703.5.1

Proponent: Tony Crimi, A.C. Consulting Solutions Inc, representing North American Insulation Manufacturers Association (NAIMA) (tcrimi@sympatico.ca)

Revise as follows:

703.5.1 Elementary materials. Materials required to be noncombustible shall be tested in accordance with ASTM E136 or ASTM E2652.

Add new standard to Chapter 35 as follows:

ASTM

E2652-09, entitled Standard Test Method for Behavior of Materials in a Tube Furnace with a Cone-shaped Airflow Stabilizer, at 750°C

Reason: There is a need for expanding the criteria used for “noncombustible material” in the IBC. Several of the I-Codes have varying definitions of the term “non-combustible material”, each based upon the way in which the concept of “non-combustible” is used within that Code. Throughout the ICC code system, the concept of “noncombustible material” is based on the idea that the material should not ignite or burn when subjected to fire or heat

Justification: The concept of “noncombustible materials” and “noncombustibility” in terms of types of construction is widely used throughout the International Codes. The IBC, IFC, IEBC and IFGC do not contain a separate definition of “noncombustible”, even though they use the terminology “non-combustible materials”.

In common usage, the term “noncombustible” is used to denote materials which do not ignite or are not capable of sustaining combustion. The common Dictionary definitions for “noncombustible” are typically as follows:

Noncombustible, adj – not capable of igniting and burning (Webster’s Third New International Dictionary of the English Language, Unabridged, 2007)

In the traditional use of the terminology and concept of “non-combustible” in the Codes has been based on acceptable performance when tested in accordance with ASTM E136, Test Method for Behavior of Materials in a Vertical Tube Furnace at 750 Degrees C. Materials passing the test are permitted limited flaming and other indications of combustion. However, these have traditionally been acceptable. Understandably, ASTM E136 does not replicate the full spectrum of actual building fire exposure conditions. However, this test method does provide an assessment indicating those materials which do not act to aid combustion or add appreciable heat to an ambient fire.

ASTM has recently published another standard ASTM E2652-09, entitled Standard Test Method for Behavior of Materials in a Tube Furnace with a Cone-shaped Airflow Stabilizer, at 750°C. This test method is similar to ASTM E136, and based more on the international standard for noncombustibility. The key difference between the two standards is in the equipment. The apparatuses in this test method and in Test Method E 136 is that the furnace tube in this test method has a conical air-flow stabilizer section attached at its bottom. Both test methods use cylindrical furnace tubes. The test Standard does not include mandatory pass/fail criterion. It allows those criteria to be determined by the Codes or other users. Appendix X3 also contains a comparison of results obtained from this apparatus versus ASTM E136. ASTM E136 has also been revised to include ASTM E2652 as an alternate methodology..

Cost Impact: This proposal does not increase the cost of construction.

Analysis: A review of the standard proposed for inclusion in the code, ASTM E2652-09 with regard to the ICC criteria for referenced standards (Section 3.6 of CP#28) will be posted on the ICC website on or before April 2, 2012.

FS10-12

Public Hearing:	Committee:	AS	AM	D
	Assembly:	ASF	AMF	DF

703.5.1-FS-CRIMI

FS11 – 12

703.7

Proponent: Maureen Traxler, City of Seattle Dept of Planning & Development, representing Washington Association of Building Officials Technical Code Development Committee (maureen.traxler@seattle.gov)

Revise as follows:

703.7 Marking and identification. ~~Where there is an accessible concealed floor, floor-ceiling or attic space, fire walls, fire barriers, fire partitions, smoke barriers and smoke partitions or any other wall required to have protected openings or penetrations shall be effectively and permanently identified with signs or stenciling in the concealed space.~~ Such identification shall:

- ~~1. Be located in accessible concealed floor, floor-ceiling or attic spaces;~~
- ~~2.1.~~ Be located within 15 feet (4572 mm) of the end of each wall and at intervals not exceeding 30 feet (9144 mm) measured horizontally along the wall or partition; and
- ~~3 2.~~ Include lettering not less than 3 inches (76 mm) in height with a minimum 3/8 inch (9.5 mm) stroke in a contrasting color incorporating the suggested wording. "FIRE AND/OR SMOKE BARRIER—PROTECT ALL OPENINGS" or other wording.

~~**Exception:** Walls in Group R-2 occupancies that do not have a removable decorative ceiling allowing access to the concealed space.~~

Reason: Section 703.7 was meant to require that the markings on fire-resistance rated assemblies only where there is an accessible space. This proposal modifies the code language to state that requirement more clearly. As written, this section requires the marking to be located in a concealed accessible space, so it requires construction of a concealed space where one would not otherwise be installed.

The exception is deleted because it becomes redundant when the marking language is clarified. If Committee feels it is necessary to maintain the exception, then it could be retained without changing the intent of the section. However, as written, the exception is unclear about what the exception applies to. Since it is indented under item 3, it appears to be an exception from the provisions related to the size of lettering.

Cost Impact: The code change proposal will not increase the cost of construction.

FS11-12

Public Hearing: Committee:	AS	AM	D
Assembly:	ASF	AMF	DF

703.7-FS-TRAXLER

FS12 – 12

704.4, 704.4.2 (New)

Proponent: Daniel E. Nichols, P.E., New York State Division of Code Enforcement and Administration, Albany, NY (dan.nichols@dos.state.ny.us)

Revise as follows:

704.4 Protection of secondary members. Secondary members that are required to have a *fire-resistance rating* shall be protected by individual encasement protection. ~~by the membrane or ceiling of a horizontal assembly in accordance with Section 711, or by a combination of both.~~

704.4.2 Horizontal Assemblies. Horizontal assemblies are permitted to be protected with a membrane or ceiling when the membrane or ceiling provides the required fire-resistance rating and are installed in accordance with Section 711.

Reason: The purpose of this proposal is to provide the code user better direction when dealing with horizontal assemblies that require a fire-resistance rating. Currently, the section is written in a way that confuses the reader by addressing all secondary structural elements and then providing a horizontal assembly alternative compliance design. If the reader were to stop reading, the following section for bearing walls for light-frame construction would be missed. This proposal separates the horizontal assemblies out of the charge section for secondary member fire resistance requirements.

Another reason for this proposal is to clarify the requirements for membrane protection of horizontal assemblies. Currently, the only direction is to Section 711. Within Section 711, there is no direct requirement on how to handle the design of a horizontal assembly when the structural members within such assembly are required to be fire-resistance-rated. The only direction within the section is how to calculate fire resistance for mixed use occupancies and fire areas. The issue with this is that the calculation is for the 'separation' of spaces rather than the 'protection' of structural elements; with the separation calculation permitting the use of the structural member (and associated bay spaces) and the floor deck and finishes to be calculated in the fire-resistance. This calculation does not provide the needed fire-resistance-rating to the structural member.

The differences in fire-resistance of commonly used rated floor assemblies can be seen using directories; such as UL's fire resistance directories for rated floors. Whereas the assemblies are rated for 1-hour, the 'finish rating' is also published at a value the is lower than the 1-hour rating since such 'finish rating' test calculates only the material that is protecting the structural member. To look at this proposal another way, the real-world reason is to ensure designers are using the finish rating calculation to determine compliance for floor member rating requirements as it applies to the requirements of Chapter 6.

Section 711 is retained to deal with installation requirements such as penetrations, ducts, and joints.

Cost Impact: This will not increase the cost of construction since this is already required by the IBC.

FS12-12

Public Hearing:	Committee:	AS	AM	D
	Assembly:	ASF	AMF	DF

704.4-FS-NICHOLS

FS13 – 12

704.4.1

Proponent: Sam Francis, American Wood Council (sfrancis@awc.org)

Revise as follows:

704.4 Protection of secondary members. Secondary members that are required to have a *fire-resistance rating* shall be protected by individual encasement protection, by the membrane or ceiling of a *horizontal assembly* in accordance with Section 711, or by a combination of both.

704.4.1 Light-frame construction. King studs and boundary elements that are integral elements in *load-bearing walls* of light-frame construction shall be permitted to have required *fire-resistance ratings* provided by the membrane protection provided for the *load-bearing wall*.

Reason: The 2009 IBC Commentary describes the rationale: “Historically, codes have considered king and jack studs in light – frame construction as standard parts of the wall assembly. King studs have essentially the same function, load ratio, and thermal properties as the other studs in the load-bearing wall, and there is no need for them to be considered separate distinct column elements.” Given that king studs are just like “regular studs”, there is no reason to make the distinction here and then explain in the commentary that no distinction in function exists. Of course, with the successful passage of this proposal, the commentary should be changed to reflect the reverse in this section, saying that this used to say king studs but since they are exactly like other studs in function, this section no longer makes the distinction and that neither regular studs, nor king studs need the individual protection required of other secondary members in a manner similar to that of horizontal secondary structural members regulated by Section 704.4.

Cost Impact: The code change proposal will not increase the cost of construction.

FS13-12

Public Hearing:	Committee:	AS	AM	D
	Assembly:	ASF	AMF	DF

704.4.1-FS-FRANCIS

FS14 – 12

705.2

Proponent: Al Godwin, CBO, CPM, representing Aon Fire Protection Engineering (al.godwin@aon.com)

Revise as follows:

705.2 Projections. Cornices, eave overhangs, exterior balconies and similar projections extending beyond the exterior wall shall conform to the requirements of this section and Section 1406. Exterior egress balconies and exterior exit stairways and ramps shall also comply with Sections 1019 and 1026, respectively. Projections shall not extend any closer to the line used to determine the fire separation distance than shown in Table 705.2.

Exception: Buildings on the same lot and considered as portions of one building in accordance with Section 705.3 are not required to comply with this section for projections between the buildings.

Reason: As written, this would exempt the building(s) from all projection regulations, even those to property lines. The exception should only apply to those projections between the buildings being considered as one building.

Cost Impact: This code change proposal will not increase the cost of construction.

FS14-12

Public Hearing:	Committee:	AS	AM	D
	Assembly:	ASF	AMF	DF

705.2-FS-GODWIN

FS15 – 12

Table 705.2

Proponent: Don Davies and Larry Lincoln, Salt Lake City Corporation, representing Utah Chapter of ICC (don.davies@slcgov.com)

Revise as follows:

**TABLE 705.2
MINIMUM DISTANCE OF PROJECTION**

FIRE SEPARATION DISTANCE (FSD)	MINIMUM DISTANCE FROM LINE USED TO DETERMINE FSD
0 feet to less than 2 feet	Projections not permitted
2 feet to less than 5 feet	24 inches
5 feet or greater	40 inches ^a

For SI: 1 foot = 304.8 mm; 1 inch = 25.4 mm

a. The minimum distance from the line used to determine FSD shall be allowed to be 24 inches (61 mm) where the building is equipped throughout with an automatic sprinkler system in accordance with section 903.3.1.1 or 903.3.1.2, including the underside of the projecting element.

Reason: This new table in the International Building Code (IBC) has simplified the rationale and approach to providing a reasonable level of safety to building projections and balconies. However, we have a concern with the new table:

- Buildings placed further from the property line are seemingly penalized with a greater fire separation distance requirement. Including our proposed footnote (a) provides justification for reducing the fire separation distance from the projection for logical reasons. This also creates an incentive for sprinkler protection for the projections. (This is particularly compelling in situations involving decks and balconies, which pose a greater fire hazards due to the possible storage and use of fire wood and barbeque grills).

Further rationale for the proposed change is an increased interest in maximizing the building footprint on small lots. Balcony projections can be common on all sides of buildings designed for these small lots; even those sides which are close to the lot line. This provision is tied to I.B.C. Table 705.8 which allows openings in the exterior wall up to 36" from the lot line if the building is equipped with ('sprinkler protection'). Also, a higher percentage of the wall is allowed unprotected openings if the building is so equipped. Our contention is, that for such buildings, a reduction in the fire separation distance would be justified especially if the balcony was sprinkler protected. In addition, the 'sprinkler protected' exception three and four for balconies and similar projections in I.B.C. Section 1406.3 insinuates that sprinkler protection of balconies is the preferred alternative, as opposed to fire-retardant treated wood or one-hour construction.

In conclusion, we feel that providing sprinkler protection on balconies and similar projections would be the preferred solution as opposed to passive fire-protective measures to provide fire-resistance, since fire-resistance rated construction will not suppress a fire nor lessen the fire exposure to a building from the same lot or from adjoining lots.

Cost Impact: None

Analysis: FS15, FS16, FS17 and FS18 provide different options for Table 705.2. The committee needs to make its intent clear with respect to these provisions.

FS15-12

Public Hearing:	Committee:	AS	AM	D
	Assembly:	ASF	AMF	DF

T705.2-FS-DAVIES-LINCOLN

FS16 – 12

Table 705.2

Proponent: Homer Maiel, PE, CBO, Town of Atherton, representing ICC Tri-Chapter (Peninsula, East Bay, and Monterey Bay)

Revise as follows:

705.2 Projections. Cornices, eave overhangs, exterior balconies and similar projections extending beyond the exterior wall shall conform to the requirements of this section and Section 1406. Exterior egress balconies and exterior exit stairways and ramps shall also comply with Sections 1019 and 1026, respectively. Projections shall not extend any closer to the line used to determine the fire separation distance than shown in Table 705.2.

**Table 705.2
MINIMUM DISTANCE OF PROTECTION**

FIRE SEPARATION DISTANCE (FSD)	MINIMUM DISTANCE FROM LINE USED TO DETERMINE FSD
0 feet to less than 2 <u>3</u> feet	Projections not permitted
2 feet to less than 5 feet <u>3 feet</u>	24 inches
5 feet or greater than 3 feet	40 inches <u>24 inches plus 8 inches for every foot thereafter</u>

Exception: Buildings on the same lot and considered as portions of one building in accordance with Section 705.3 are not required to comply with this section.

Reason: The current code language which was changed as the result of approval of FS12-09/10 in Baltimore, has simplified the projection requirements a great deal. However, there is a flaw in Table 705.2.

In Fig. 1, I am trying to compare 2009 requirements with 2012. In 2009 code, the projection was a function of, 1) distance of exterior face of the wall to the lot line where protected openings or a combination of protected and unprotected openings are required, 2) automatic sprinkler systems. The 2012 code simplifies Section 705.2 by eliminating both of those requirements. In 2012, the only function is FSD. Once FSD is determined, then the projection is measured from FSD. This is shown in Fig. 1.

In Table 705.2, the third row is where the flaw appears. For example, if the FSD is 4 feet, then the minimum distance for projection to FSD is 24 inches. That means the maximum allowable projection can be 24 inches (48" – 24"). On the other hand, if FSD is 5 feet, then the minimum distance from the line used to determine FSD is 40". That means that projection can only be 20" (60" - 40"). Less projection is allowed for 5' FSD than 4' FSD!! This is clearly shown in Fig. 2. Also Fig. 3 shows this flaw and at the same time 2009 and 2012 have been compared graphically.

The new proposal still maintains the simplicity that is introduced in 2012 along with incorporating 2009 numbers.

2009

2012

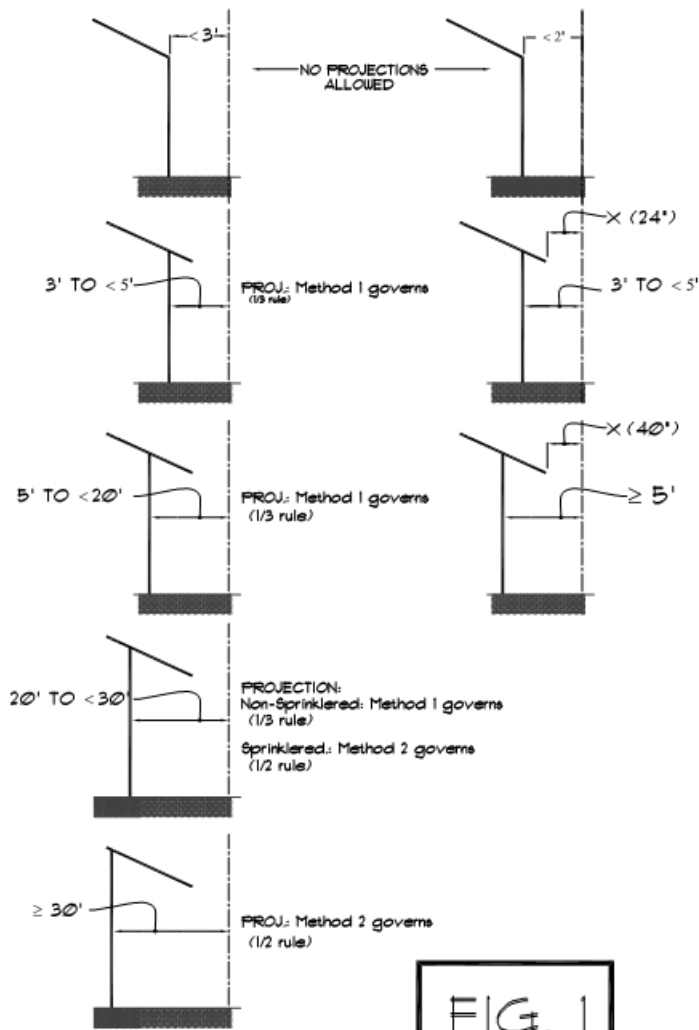
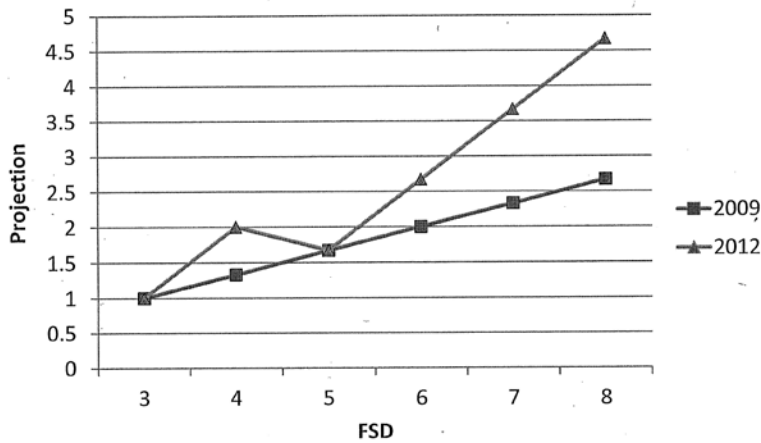

Fig. 2

FSD	2009		2012	
< 2'	NP		NP	
2' - < 3'	NP		Proj.	From Edge of Proj. to PL (x)
			0.9'	2'
3'	Proj.	X	1'	2'
	1'	2'		
4'	1.33	2.67	2'	2'
5'	1.67	3.33 (40")	1.67	3.33 (40")
6'	2	4	2.67	3.33 (40")
7'	2.33	4.67	3.67	3.33 (40")
8'	2.67	5.33	4.67	3.33 (40")
...
20'	Sprk.		Non-Sprk.	
	Proj.	X	Proj.	X
	10	10	6.67	13.3

Fig. 3



Cost Impact: This code change will not increase the cost of construction.

Analysis: FS15, FS16, FS17 and FS18 provide different options for Table 705.2. The committee needs to make its intent clear with respect to these provisions.

FS16-12

Public Hearing: Committee: AS AM D
 Assembly: ASF AMF DF

T705.2-FS-MAIEL

FS17 – 12

705.2, Table 705.2

Proponent: Ali M. Fattah, P.E., City of San Diego, representing the San Diego Area Chapter of ICC (afattah@sandiego.gov)

Revise as follows:

705.1 General. Exterior walls shall comply with this section.

705.2 Projections. Cornices, eave overhangs, exterior balconies and similar projections extending beyond the exterior wall shall conform to the requirements of this section and Section 1406. Exterior egress balconies and exterior exit stairways and ramps shall also comply with Sections 1019 and 1026, respectively. Projections shall not extend any closer to the line used to determine encroachment into the fire separation distance more than the distance determined from ~~than shown in~~ Table 705.2.

**TABLE 705.2
MINIMUM DISTANCE OF PROJECTION**

FIRE SEPARATION DISTANCE (FSD)	MINIMUM DISTANCE TO PROJECTION FROM LINE USED TO DETERMINE (FSD)	
	Sprinkler Protected (S)	Non-sprinkler Protected (NS)
0 feet to less than 2 feet	Projections not permitted	Projections not permitted
2 feet to less than 5	24 inches	
5 feet or greater	40 inches	
2 feet to less than 20	$\frac{2}{3}$ of the fire separation distance	$\frac{2}{3}$ of the fire separation distance
20 feet to less than 30 ft	$\frac{1}{2}$ of the fire separation distance	$\frac{2}{3}$ of the fire separation distance
30 feet or greater	10 ft	15 ft

For SI: 1 foot = 304.8 mm; 1 inch = 25.4 mm.

Reason: This proposed change to modify Table 705.2 is necessary due to consequences of approval and adoption of FS 12-09/10 into the table. The 2012 IBC permits a large outdoor seating area of restaurant that includes seating or other useable space below to be located a distance of up to 40inch from a lot line. This same condition under a legacy code would have resulted in distances such as 13.33 ft or 6.67 ft depending on the type of construction. While the 2006 IBC implied that a projection projects beyond the building areas, the 2009 IBC and subsequent edition changed the description to be beyond the exterior wall. As a consequence a post and beam supported attached deck or cantilevered balconies can be considered to be projections and often include useable space beneath them.

As an example the 2012 IBC allows a 5 stories plus mezzanine R-2 occupancy constructed of Type III A Sprinkler protected construction can be located 15 ft from a lot line and can include a 11 ft 8 inch deep balcony on the side of the building stacked on every level and 75% of the exterior wall can include unprotected openings. The projection should be limited to 5 ft to allow 10 ft ($\frac{2}{3}$ of the fire separation distance to be unobstructed).

- Sprinkler protection of the useable space beneath the projection does not adequately protect the hazard; if it did the code would have permitted enclosed sprinkler protected space.
- What would occur if the resident chooses to glaze the balcony by adding windows on top of the guard, would that constitute an opening and if so will that make the condition worse to cause non-compliance? Does not including a window above the guard make the condition better?

The limitation on the length of projections encroaching into the fire separation distance is to limit combustibles in the building construction and furnishings that can expose adjacent buildings. Table 705.2 and Section 705.2 do not differentiate between combustible and non-combustible construction. This code change attempts to make that differentiation and includes the requirements in 2009 IBC Section 705.2 in tabular form.

- Exterior exit balconies are required in Section 1019.4 to be 10 ft away from unprotected openings in adjacent buildings or from lot lines to allow occupants to safely egress through exterior egress balconies.
- It makes no sense to protect the exterior walls of a building per TABLE 602 and to allow elements that bring the fire loading closer to a neighboring building.
- Exterior walls are protected to prevent their collapse and thereby preventing larger openings in collapsed walls that would expose neighboring buildings.

- Section 1406.3 does not adequately address the issues of balconies since it is mainly concerned with flammability of the construction and impacts the exterior of the building.

Technical justification is not available through the activities of the various code drafting and code development committees to substantiate the reason for the limitations and to facilitate engineering based justification. It seems reasonable to expect that 2/3 or 1/2 of the fire separation remain clear to prevent the spread of fire to neighboring structures and buildings.

Determination of the permissible length for projections based on fire separation distance has been problematic since the development of the IBC working draft in 1997. At that time the drafting committee adopted the UBC's permissible projection measurement methodology and triggered it based the IBC's opening protection table (opening limitation and size control table) initially for combustible projections and then in the final draft projections in general. The problem arises due to the fact that IBC Table 705.8 limits the area of exterior wall openings as a percentage of the exterior wall area based on fire separation distance, whether or not the opening is fire resistance rated and whether the building is protected throughout with an automatic fire sprinkler system.

- The legacy code from which Section 705.2 was developed offered fewer options and triggered opening protection at 3 ft, 10 ft or 20ft fire separation distance based on occupancy and type of construction. Openings were limited to a maximum of 50% of the area of the wall per story.
- Projection limitations were simpler to determine under the legacy code since only a limited number of distances based on the occupancy and type of construction of the building. Furthermore, most legacy code users considered the edge of the project to create an exterior wall opening since the area below the projection created building area.

Several code change proposals in the last three code cycles sought to remedy this situation and were submitted by groups that had used the same legacy code.

- FS 70-03/04 was submitted but not approved to account to limit projections in locations due to requirements in other than Section 704.
- FS 16-06/07 Section 704.2 was proposed without limitations to the separation to a lot line or imaginary line for non-combustible projections. Section 704.2.3 proposed to require that combustible projections be protected for 1 hour when located closer than 6 ft from a lot line or imaginary line. This proposed code change was not approved.
- FS 14-07/08 and FS 15-07/08 were submitted and the latter code change was published in the 2009 IBC. The 2009 IBC includes two triggers that differentiate between whether opening protection is required or not by 2009 IBC Table 705.8.
- FS 11-09/10 and FS 12-09/10 sought to simplify Section 705.2 of the 2009 IBC by displaying the projection limitations in tabular form. The latter code change was approved and published in the 2012 IBC after approval of public comment. The first code change sought limit the projections based on occupancy, type construction and fire separation distance.

As an example of the differences to what a legacy code the Uniform Building Code would have required I have attached a summary table showing the projection limitations.

**TABLE 705.2
MINIMUM DISTANCE TO PROJECTION
Based on 1997 UBC**

FIRE SEPARATION DISTANCE X (feet)	TYPE OF CONSTRUCTION	MINIMUM DISTANCE TO PROJECTION FROM LINE USED TO DETERMINE (FSD)				
		OCCUPANCY GROUP A-1, A-2, A2.1, A-3, A-4	OCCUPANCY GROUP B, F-1, M, S-1, S-3	OCCUPANCY GROUP E-1, E-2, E-3, F-2, S-2, H-2, H-3, H-4, H-6, H-7 A, B, E, F-2, I, R, S-2, U	OCCUPANCY GROUP I1.1, I1.2, I-2, I-3, R-1	OCCUPANCY GROUP R-3
X ≤ 3 ft	All	NP	NP	NP	NP	1 ft
3 < X ≤ 5	I A, IB	NP	NP	NP (F-2, S-2 2/3)	NP (R-1 2/3)	2/3
	II A, IIB	NP	NP	NP	NP	2/3
	III, IV	NP	NP	NP	NP (R-1 2/3)	2/3
	V	NP	NP	NP	NP	2/3

FIRE SEPARATION DISTANCE X (feet)	TYPE OF CONSTRUCTION	MINIMUM DISTANCE TO PROJECTION FROM LINE USED TO DETERMINE (FSD)				
		OCCUPANCY GROUP A-1, A-2, A2.1, A-3, A-4	OCCUPANCY GROUP B, F-1, M, S-1, S-3	OCCUPANCY GROUP E-1, E-2, E-3, F-2, S-2, H-2, H-3, H-4, H-6, H-7 A, B, E, F-2, I, R, S-2, U	OCCUPANCY GROUP I1.1, I1.2, I-2, I-3, R-1	OCCUPANCY GROUP R-3
5 < X ≤ 10	I A, IB	2/3 (H-5 NP)	2/3 (H-5 NP)	2/3 (H-5 NP)	2/3 (H-5 NP)	2/3 (H-5 NP)
	II A, IIB	2/3 (H-5 NP)	2/3 (H-5 NP)	2/3 (H-5 NP)	2/3 (H-5 NP)	2/3 (H-5 NP)
	III, IV	2/3 (H-5 NP)	2/3 (H-5 NP)	2/3 (H-5 NP)	2/3 (H-5 NP)	2/3 (H-5 NP)
	V	2/3 (H-5 NP)	2/3 (H-5 NP)	2/3 (H-5 NP)	2/3 (H-5 NP)	2/3 (H-5 NP)
10 < X ≤ 20	I A, IB	2/3 (A-2, A2.1 A-3 A-4 6.7ft) (H-5 NP)	2/3 (H-5 NP)	2/3 (H-5 NP)	2/3 (H-5 NP)	2/3 (H-5 NP)
	II A, IIB	2/3 (A-2, A2.1 A-3 A-4 13.33 ft) (H-5 NP)	6.7 ft (H-5 NP)	2/3 (E 13.33 ft) (H-5 NP)	2/3 (I-2 13.33 ft) (H-5 NP)	2/3 (H-5 NP) (R-1 3.33 ft, R-3 2 ft)
	III, IV	2/3 (H-5 NP)	2/3 (H-5 NP)	2/3 (H-5 NP)	2/3 (H-5 NP)	2/3 (H-5 NP)
	V	2/3 (A-4 6.7ft) (H-5 NP)	6.7 ft (H-5 NP)	2/3 (H-5 NP)	2/3 (H-5 NP) (I-2 13.33 ft)	2/3 (H-5 NP) (R-1 3.33 ft, R-3 2 ft)
20 < X ≤ 60	I A, IB	13.33 ft (H-5 NP)	13.33 ft (H-5 NP)	13.33 ft (H-5 NP)	13.33 ft (H-5 NP)	13.33 ft (H-5 NP)
	II A, IIB	13.33 ft (H-5 NP)	13.33 ft (H-5 NP)	13.33 ft (H-5 NP)	13.33 ft (H-5 NP)	13.33 ft (H-5 NP)
	III, IV	13.33 ft (H-5 NP)	13.33 ft (H-5 NP)	13.33 ft (H-5 NP)	13.33 ft (H-5 NP)	13.33 ft (H-5 NP)
	V	13.33 ft (H-5 NP)	13.33 ft (H-5 NP)	13.33 ft (H-5 NP)	13.33 ft (H-5 NP)	13.33 ft (H-5 NP) (R-1 3.33 ft, R-3 2 ft)
20 < X ≤ 60	I A, IB	13.33 ft (H-5 NP)	13.33 ft (H-5 NP)	13.33 ft (H-5 NP)	13.33 ft (H-5 NP)	13.33 ft (H-5 NP)
	II A, IIB	13.33 ft (H-5 NP)	13.33 ft (H-5 NP)	13.33 ft (H-5 NP)	13.33 ft (H-5 NP)	13.33 ft (H-5 NP)
	III, IV	13.33 ft (H-5 NP)	13.33 ft (H-5 NP)	13.33 ft (H-5 NP)	13.33 ft (H-5 NP)	13.33 ft (H-5 NP)
	V	13.33 ft (H-5 NP)	13.33 ft (H-5 NP)	13.33 ft (H-5 NP)	13.33 ft (H-5 NP)	13.33 ft (H-5 NP) (R-1 3.33 ft, R-3 2 ft)

FIRE SEPARATION DISTANCE X (feet)	TYPE OF CONSTRUCTION	MINIMUM DISTANCE TO PROJECTION FROM LINE USED TO DETERMINE (FSD)				
		OCCUPANCY GROUP A-1, A-2, A2.1, A-3, A-4	OCCUPANCY GROUP B, F-1, M, S-1, S-3	OCCUPANCY GROUP E-1, E-2, E-3, F-2, S-2, H-2, H-3, H-4, H-6, H-7 A, B, E, F-2, I, R, S-2, U	OCCUPANCY GROUP I1.1, I1.2, I-2, I-3, R-1	OCCUPANCY GROUP R-3
X ≥ 60	I A, IB	13.33 ft (H-5 2/3 > 60 ft)	13.33 ft (H-5 2/3 > 60 ft)	13.33 ft (H-5 2/3 > 60 ft)	13.33 ft (H-5 2/3 > 60 ft)	13.33 ft (H-5 2/3 > 60 ft)
	II A, IIB	13.33 ft (H-5 2/3 > 60 ft)	13.33 ft (H-5 2/3 > 60 ft)	13.33 ft (H-5 2/3 > 60 ft)	13.33 ft (H-5 2/3 > 60 ft)	13.33 ft (H-5 2/3 > 60 ft)
	III, IV	13.33 ft (H-5 2/3 > 60 ft)	13.33 ft (H-5 2/3 > 60 ft)	13.33 ft (H-5 2/3 > 60 ft)	13.33 ft (H-5 2/3 > 60 ft)	13.33 ft (H-5 2/3 > 60 ft)
	V	13.33 ft (H-5 2/3 > 60 ft)	13.33 ft (H-5 2/3 > 60 ft)	13.33 ft (H-5 2/3 > 60 ft)	13.33 ft (H-5 2/3 > 60 ft)	13.33 ft (H-5 2/3 > 60 ft)

Reason: This proposed This code change to Table 705.2 is necessary since the table allows a 4 story Type VB building required to have protected exterior walls and exterior wall openings to include balconies used in restaurants or as a projection from dwellings to be located 40 inches from a lot line and thereby introducing a fire load that exposes a neighboring building. Exterior exit balconies are required in Section 1019.4 to be 10 ft away from unprotected openings in adjacent buildings or from lot lines to allow occupants to safely egress through exterior egress balconies. It makes no sense to protect the exterior walls of a building per TABLE 602 and to allow elements that bring the fire loading closer to a neighboring building. Section 1406.3 does not adequately address the issues of balconies since it is mainly concerned with flammability of the construction as to impacts the exterior of the building. The code change that resulted in the table was well intentioned and resulted in a simplified table and sought to establish a single line beyond which projection could not be closer to a lot line. However the IBC's fire separation concept involves triggering requirements based on the actual location of the building and establishing a uniform line may be less restrictive for larger buildings constructed of higher types of construction and housing higher hazard occupancies.

Code changes FS11-09/10 and FS12-09/10 http://www.iccsafe.org/cs/codes/Documents/2009-10cycle/FAA/IBC-FS_%20FS2-FS100.pdf, the latter of which was approved after public comment and adopted into the 2012 IBC, sought to address an issue that arose from combining projection requirements driven through opening protection that was developed under a legacy code with the revised opening protection philosophy of the IBC that limits the size of openings within fire separation distance ranges. Legacy codes required opening protection for openings located in walls located at a fire separation distance less than a predetermined distance. As a consequence the length of projections was limited when based on the distance where opening protection was first required. Projections, especially projections providing shelter for useable spaces such as patios used typically in residential occupancies and drinking and dining establishments as well as offices and educational occupancies. I

BC Section 1019.4 requires that exterior egress balconies be located not less than 10 ft from a lot line or a building to protect occupants in the means of egress from unprotected exposures, and this separation is required regardless of whether sprinkler protection is provided. It therefore makes no sense to permit a balcony located on a hi-rise building with a fire separation distance of 20 ft to be located up to 44 inches from a lot line even if sprinkler protection is provided for.

The useable balcony whether cantilevered or supported extends beyond the exterior wall and allows for combustible furnishings to be located in close proximity to a neighboring building. The IBC intends for fire separation to occur through distance, 30 ft or more to a lot line or imaginary line, or through exterior wall and opening protection. By protecting exterior walls and limiting the amount of exterior wall openings the IBC seeks to contain fire within the area of origin and to limit exposure to neighboring buildings due to the premature collapse of the exterior wall resulting in larger exterior wall openings or due to large unprotected openings that allow fire to spread to adjacent buildings and areas. Projections were proportioned to allow 2/3 of the space between the building and the lot line/imaginary line to be open and therefore allow for heat, flame and products of combustion to disperse. The 2009 IBC gave credit for sprinklers to allow for a level of protection and allowed a reduction to 1/2 the distance when the building is protected throughout with a fire sprinkler system.

<u>FIRE SEPARATION DISTANCE</u>	<u>MINIMUM DISTANCE TO PROJECTION FROM LINE USED TO DETERMINE (FSD)</u>
--	--

<u>X (feet)</u>	<u>Sprinkler Protected (S)</u>	<u>Non-sprinkler Protected (NS)</u>
<u>$X \leq 2$ ft</u>	<u>NP</u>	<u>NP</u>
<u>$X \leq 3$ ft</u>	<u>1 ft</u>	<u>NP</u>
<u>$2 < X < 5$</u>	<u>1.67 ft</u>	<u>1.67 ft</u>
<u>$5 \leq X < 10$</u>	<u>6.67 ft</u>	<u>6.67 ft</u>
<u>$10 \leq X < 15$</u>	<u>10 ft</u>	<u>10 ft</u>
<u>$15 \leq X < 20$</u>	<u>13.3 ft</u>	<u>13.3 ft</u>
<u>$20 \leq X < 30$</u>	<u>15 ft</u>	<u>20 ft</u>
<u>30 feet or greater</u>	<u>15 ft</u>	<u>20 ft</u>

Reason: This code change is necessary to allow storage rooms and closets located in any occupancy to not be considered an S occupancy. The revisions to the incidental uses Table 509 over the last two code cycles removed small storage rooms as a consequence they need to be classified as Group S and considered accessory use or a separated or non-separated occupancy.

Closets and storage rooms located in occupancies located in multistory buildings permitted otherwise to be of non-rated construction will be limited to buildings constructed of Type VA, IIIA or IIA construction or better. For example storage rooms and closets located above the second floor in a Group R-1 or Group R-2 occupancy four stories in height will require one-hour construction throughout or will not be permitted above the second story. Another example is a janitor's closet in a common area or a janitors closet located within a multi-tenant building. Proposed exception 4 seeks to address this issue.

A small electrical/mechanical room located on the 5th floor of a type IIB building would not be permitted as accessory uses since Section 508.2.3 requires that the allowable height be established without increase for the accessory use. The electrical code and mechanical code and incidental use requirements will require the appropriate separation from the remainder of the building where appropriate. Proposed exception 5 addresses this issue.

Cost Impact: None. The code change proposal will not increase the cost of construction.

Analysis: FS15, FS16, FS17 and FS18 provide different options for Table 705.2. The committee needs to make its intent clear with respect to these provisions.

FS17-12

Public Hearing: Committee: AS AM D
Assembly: ASF AMF DF

T705.2 #1-FS-FATTAH

FS18 – 12

705.2, Table 705.2

Proponent: Ali M. Fattah, P.E., City of San Diego, representing the San Diego Area Chapter of ICC (afattah@sandiego.gov)

Revise as follows:

705.1 General. Exterior walls shall comply with this section.

705.2 Projections. Cornices, eave overhangs, exterior balconies and similar projections extending beyond the exterior wall shall conform to the requirements of this section and Section 1406. Exterior egress balconies and exterior exit stairways and ramps shall also comply with Sections 1019 and 1026, respectively. Projections shall not extend any closer to the line used to determine encroachment into the fire separation distance more than the distance determined from ~~than shown in~~ Table 705.2.

TABLE 705.2
MINIMUM DISTANCE OF PROJECTION

FIRE SEPARATION DISTANCE (FSD)	MINIMUM DISTANCE FROM LINE USED TO DETERMINE FSD
0 feet to less than 2 feet	Projections not permitted
2 feet to less than 5	24 inches
5 feet or greater	40 inches

TABLE 705.2
MINIMUM DISTANCE OF PROJECTION

FIRE SEPARATION DISTANCE X (feet)	TYPE OF CONSTRUCTION	MINIMUM DISTANCE TO PROJECTION FROM LINE USED TO DETERMINE (FSD)	
		Sprinkler Protected (S)	Non-sprinkler Protected (NS)
$X \leq 2$ ft	All	NP	NP
$2 \leq X < 3$ ft	All	1 ft	NP
$3 < X < 20$	I, II	$\frac{1}{2}$ of the fire separation distance	$\frac{1}{2}$ of the fire separation distance
	III, IV, V	$\frac{2}{3}$ of the fire separation distance	$\frac{2}{3}$ of the fire separation distance
$20 \leq X < 30$	I, II	$\frac{1}{2}$ of the fire the fire separation distance	$\frac{1}{2}$ of the fire the fire separation distance
	III, IV, V	$\frac{1}{2}$ of the fire the fire separation distance	$\frac{2}{3}$ of the fire separation distance
$X \geq 30$	All	10 ft	15 ft

For SI: 1 foot = 304.8 mm; 1 inch = 25.4 mm.

Reason: This proposed change to replace Table 705.2 is necessary due to consequences of approval and adoption of FS 12-09/10 into the table. The 2012 IBC permits a large outdoor seating area of restaurant that includes seating or other useable space below to be located a distance of up to 40inch from a lot line. This same condition under a legacy code would have resulted in distances such as 13.33 ft or 6.67 ft depending on the type of construction. While the 2006 IBC implied that a projection projects beyond the building areas, the 2009 IBC and subsequent edition changed the description to be beyond the exterior wall. As a consequence a

post and beam supported attached deck or cantilevered balconies can be considered to be projections and often include useable space beneath them. This code change differentiates between combustible and non-combustible projections due a substantial reduction in the combustible loading contributed by the building construction.

As an example the 2012 IBC allows a 5 stories plus mezzanine R-2 occupancy constructed of Type III A Sprinkler protected construction can be located 15 ft from a lot line and can include a 11 ft 8 inch deep balcony on the side of the building stacked on every level and 75% of the exterior wall can include unprotected openings. The projection should be limited to 5 ft to allow 10 ft (2/3 of the fire separation distance to be unobstructed).

- Sprinkler protection of the useable space beneath the projection does not adequately protect the hazard; if it did the code would have permitted enclosed sprinkler protected space.
- What would occur if the resident chooses to glaze the balcony by adding windows on top of the guard, would that constitute an opening and if so will that make the condition worse to cause non-compliance? Does not including a window above the guard make the condition better?

The limitation on the length of projections encroaching into the fire separation distance is to limit combustibles in the building construction and furnishings that can expose adjacent buildings. Table 705.2 and Section 705.2 do not differentiate between combustible and non-combustible construction. This code change attempts to make that differentiation and includes the requirements in 2009 IBC Section 705.2 in tabular form.

- Exterior exit balconies are required in Section 1019.4 to be 10 ft away from unprotected openings in adjacent buildings or from lot lines to allow occupants to safely egress through exterior egress balconies.
- It makes no sense to protect the exterior walls of a building per TABLE 602 and to allow elements that bring the fire loading closer to a neighboring building.
- Exterior walls are protected to prevent their collapse and thereby preventing larger openings in collapsed walls that would expose neighboring buildings.
- Section 1406.3 does not adequately address the issues of balconies since it is mainly concerned with flammability of the construction and impacts the exterior of the building.

Technical justification is not available through the activities of the various code drafting and code development committees to substantiate the reason for the limitations and to facilitate engineering based justification. It seems reasonable to expect that 2/3 or 1/2 of the fire separation remain clear to prevent the spread of fire to neighboring structures and buildings.

Determination of the permissible length for projections based on fire separation distance has been problematic since the development of the IBC working draft in 1997. At that time the drafting committee adopted the UBC's permissible projection measurement methodology and triggered it based the IBC's opening protection table (opening limitation and size control table) initially for combustible projections and then in the final draft projections in general. The problem arises due to the fact that IBC Table 705.8 limits the area of exterior wall openings as a percentage of the exterior wall area based on fire separation distance, whether or not the opening is fire resistance rated and whether the building is protected throughout with an automatic fire sprinkler system.

- The legacy code from which Section 705.2 was developed offered fewer options and triggered opening protection at 3 ft, 10 ft or 20ft fire separation distance based on occupancy and type of construction. Openings were limited to a maximum of 50% of the area of the wall per story.
- Projection limitations were simpler to determine under the legacy code since only a limited number of distances based on the occupancy and type of construction of the building. Furthermore, most legacy code users considered the edge of the project to create an exterior wall opening since the area below the projection created building area.

Several code change proposals in the last three code cycles sought to remedy this situation and were submitted by groups that had used the same legacy code.

- FS 70-03/04 was submitted but not approved to account to limit projections in locations due to requirements in other than Section 704.
- FS 16-06/07 Section 704.2 was proposed without limitations to the separation to a lot line or imaginary line for non-combustible projections. Section 704.2.3 proposed to require that combustible projections be protected for 1 hour when located closer than 6 ft from a lot line or imaginary line. This proposed code change was not approved.
- FS 14-07/08 and FS 15-07/08 were submitted and the latter code change was published in the 2009 IBC. The 2009 IBC includes two triggers that differentiate between whether opening protection is required or not by 2009 IBC Table 705.8.
- FS 11-09/10 and FS 12-09/10 sought to simplify Section 705.2 of the 2009 IBC by displaying the projection limitations in tabular form. The latter code change was approved and published in the 2012 IBC after approval of public comment. The first code change sought limit the projections based on occupancy, type construction and fire separation distance.

As an example of the differences to what a legacy code the Uniform Building Code would have required I have attached a summary table showing the projection limitations.

**TABLE 705.2
MINIMUM DISTANCE TO PROJECTION
Based on 1997 UBC**

FIRE SEPARATION DISTANCE X (feet)	TYPE OF CONSTRUCTION	MINIMUM DISTANCE TO PROJECTION FROM LINE USED TO DETERMINE (FSD)				
		OCCUPANCY GROUP A-1, A-2, A2.1, A-3, A-4	OCCUPANCY GROUP B, F-1, M, S-1, S-3	OCCUPANCY GROUP E-1, E-2, E-3, F-2, S-2, H-2, H-3, H-4, H-6, H-7 A, B, E, F-2, I, R, S-2, U	OCCUPANCY GROUP I1.1, I1.2, I-2, I-3, R-1	OCCUPANCY GROUP R-3
X ≤ 3 ft	All	NP	NP	NP	NP	1 ft
3 < X ≤ 5	I A, IB	NP	NP	NP (F-2, S-2 2/3)	NP (R-1 2/3)	2/3
	II A, IIB	NP	NP	NP	NP	2/3
	III, IV	NP	NP	NP	NP (R-1 2/3)	2/3
	V	NP	NP	NP	NP	2/3
5 < X ≤ 10	I A, IB	2/3 (H-5 NP)	2/3 (H-5 NP)	2/3 (H-5 NP)	2/3 (H-5 NP)	2/3 (H-5 NP)
	II A, IIB	2/3 (H-5 NP)	2/3 (H-5 NP)	2/3 (H-5 NP)	2/3 (H-5 NP)	2/3 (H-5 NP)
	III, IV	2/3 (H-5 NP)	2/3 (H-5 NP)	2/3 (H-5 NP)	2/3 (H-5 NP)	2/3 (H-5 NP)
	V	2/3 (H-5 NP)	2/3 (H-5 NP)	2/3 (H-5 NP)	2/3 (H-5 NP)	2/3 (H-5 NP)
10 < X ≤ 20	I A, IB	2/3 (A-2, A2.1 A-3 A-4 6.7ft) (H-5 NP)	2/3 (H-5 NP)	2/3 (H-5 NP)	2/3 (H-5 NP)	2/3 (H-5 NP)
	II A, IIB	2/3 (A-2, A2.1 A-3 A-4 13.33 ft) (H-5 NP)	6.7 ft (H-5 NP)	2/3 (E 13.33 ft) (H-5 NP)	2/3 (I-2 13.33 ft) (H-5 NP)	2/3 (H-5 NP) (R-1 3.33 ft, R-3 2 ft)
	III, IV	2/3 (H-5 NP)	2/3 (H-5 NP)	2/3 (H-5 NP)	2/3 (H-5 NP)	2/3 (H-5 NP)
	V	2/3 (A-4 6.7ft) (H-5 NP)	6.7 ft (H-5 NP)	2/3 (H-5 NP)	2/3 (H-5 NP) (I-2 13.33 ft)	2/3 (H-5 NP) (R-1 3.33 ft, R-3 2 ft)
20 < X ≤ 60	I A, IB	13.33 ft (H-5 NP)	13.33 ft (H-5 NP)	13.33 ft (H-5 NP)	13.33 ft (H-5 NP)	13.33 ft (H-5 NP)
	II A, IIB	13.33 ft (H-5 NP)	13.33 ft (H-5 NP)	13.33 ft (H-5 NP)	13.33 ft (H-5 NP)	13.33 ft (H-5 NP)
	III, IV	13.33 ft (H-5 NP)	13.33 ft (H-5 NP)	13.33 ft (H-5 NP)	13.33 ft (H-5 NP)	13.33 ft (H-5 NP)
	V	13.33 ft (H-5 NP)	13.33 ft (H-5 NP)	13.33 ft (H-5 NP)	13.33 ft (H-5 NP)	13.33 ft (H-5 NP) (R-1 3.33 ft, R-3 2 ft)
20 < X ≤ 60	I A, IB	13.33 ft (H-5 NP)	13.33 ft (H-5 NP)	13.33 ft (H-5 NP)	13.33 ft (H-5 NP)	13.33 ft (H-5 NP)
	II A, IIB	13.33 ft (H-5 NP)	13.33 ft (H-5 NP)	13.33 ft (H-5 NP)	13.33 ft (H-5 NP)	13.33 ft (H-5 NP)
	III, IV	13.33 ft	13.33 ft	13.33 ft	13.33 ft	13.33 ft

FIRE SEPARATION DISTANCE X (feet)	TYPE OF CONSTRUCTION	MINIMUM DISTANCE TO PROJECTION FROM LINE USED TO DETERMINE (FSD)				
		OCCUPANCY GROUP A-1, A-2, A2.1, A-3, A-4	OCCUPANCY GROUP B, F-1, M, S-1, S-3	OCCUPANCY GROUP E-1, E-2, E-3, F-2, S-2, H-2, H-3, H-4, H-6, H-7 A, B, E, F-2, I, R, S-2, U	OCCUPANCY GROUP I1.1, I1.2, I-2, I-3, R-1	OCCUPANCY GROUP R-3
		(H-5 NP)	(H-5 NP)	(H-5 NP)	(H-5 NP)	(H-5 NP)
	V	13.33 ft (H-5 NP)	13.33 ft (H-5 NP)	13.33 ft (H-5 NP)	13.33 ft (H-5 NP)	13.33 ft (H-5 NP) (R-1 3.33 ft, R-3 2 ft)
X ≥ 60	I A, IB	13.33 ft (H-5 2/3 > 60 ft)	13.33 ft (H-5 2/3 > 60 ft)	13.33 ft (H-5 2/3 > 60 ft)	13.33 ft (H-5 2/3 > 60 ft)	13.33 ft (H-5 2/3 > 60 ft)
	<u>II A, IIB</u>	13.33 ft (H-5 2/3 > 60 ft)	13.33 ft (H-5 2/3 > 60 ft)	13.33 ft (H-5 2/3 > 60 ft)	13.33 ft (H-5 2/3 > 60 ft)	13.33 ft (H-5 2/3 > 60 ft)
	<u>III, IV</u>	13.33 ft (H-5 2/3 > 60 ft)	13.33 ft (H-5 2/3 > 60 ft)	13.33 ft (H-5 2/3 > 60 ft)	13.33 ft (H-5 2/3 > 60 ft)	13.33 ft (H-5 2/3 > 60 ft)
	<u>V</u>	13.33 ft (H-5 2/3 > 60 ft)	13.33 ft (H-5 2/3 > 60 ft)	13.33 ft (H-5 2/3 > 60 ft)	13.33 ft (H-5 2/3 > 60 ft)	13.33 ft (H-5 2/3 > 60 ft)

Cost Impact: None. The code change proposal will not increase the cost of construction.

Analysis: FS15, FS16, FS17 and FS18 provide different options for Table 705.2. The committee needs to make its intent clear with respect to these provisions.

FS18-12

Public Hearing: Committee: AS AM D
Assembly: ASF AMF DF

T705.2 #2-FS-FATTAH

FS19 – 12

705.2.3

Proponent: Steve Thomas, Colorado Code Consulting, LLC representing the Colorado Chapter ICC (stthomas@coloradocode.net)

Revise as follows:

705.2.3 Combustible projections. Combustible projections extending to within 5 feet (1524 mm) of the line used to determine the fire separation distance, ~~or located where openings are not permitted, or where protection of some openings is required~~ shall be of at least 1-hour fire-resistance- rated construction, Type IV construction, fire-retardant-treated wood or as required by Section 1406.3.

Exception: Type VB construction shall be allowed for combustible projections in Group R-3 and U occupancies with a fire separation distance greater than or equal to 5 feet (1524 mm).

Reason: This section was revised during the last code cycle by several different changes. The deleted language is confusing to the user of the code. The base requirement of 5 feet already addresses projections that are located where openings are prohibited (3 feet). Therefore, the language "or located wher openings are not permitted" is not needed. The language, "or where protection of some openings is required" is very confusing. What does it mean to say some opening protection is required? Is there a certain percentage of openings that makes it "some"? There is no direction for the user of the code to enforce this language.

Cost Impact: The code change proposal will not increase the cost of construction.

FS19-12

Public Hearing:	Committee:	AS	AM	D
	Assembly:	ASF	AMF	DF

705.2.3-FS-THOMAS

FS20 – 12

705.3, Table 705.8

Proponent: Marshall A. Klein, P.E., Marshall A. Klein & Associates, Inc., representing National Multi-Housing Council

Revise as follows:

705.3 Buildings on the same lot. For the purposes of determining the required wall and opening protection, projections and roof-covering requirements, buildings on the same lot shall be assumed to have an imaginary line between them. Space where a new building is to be erected on the same lot as an existing building, the location of the assumed imaginary line with relation to the existing building shall be such that the *exterior wall* and opening protection of the existing building meet the criteria as set forth in Sections 705.5 and 705.8.

Exceptions:

1. Two or more buildings on the same lot shall either be regulated as separate buildings or shall be considered as portions of one building if the aggregate area of such buildings is within the limits specified in Chapter 5 for a single building. Where the buildings contain different occupancy groups or are of different types of construction, the area shall be that allowed for the most restrictive occupancy or construction.
2. Where an S-2 parking garage is erected on the same lot as a Group R-2 building, and there is no fire separation distance between these buildings, then the adjoining exterior walls between the buildings are permitted to have occupant use openings in accordance with Section 706.8. However, opening protectives in such openings shall only be required in the exterior wall of the S-2 parking garage, not in the exterior wall openings in the R-2 building, and these opening protectives in the exterior wall of the S-2 parking garage shall be a minimum of 1½ hours fire protection rating.

**TABLE 705.8
MAXIMUM AREA OF EXTERIOR WALL OPENINGS BASED ON
FIRE SEPARATION DISTANCE AND DEGREE OF OPENING PROTECTION**

FIRE SEPARATION DISTANCE (feet)	DEGREE OF OPENING PROTECTION	ALLOWABLE AREA^a
0 to less than 3 ^{b,c,k}	Unprotected, Nonsprinklered (UP, NS)	Not Permitted ^k
	Unprotected, Sprinklered (UP, S) ^l	Not Permitted ^k
	Protected (P)	Not Permitted ^k

(Portions of table not shown remain unchanged)

(Footnotes a through j remain unchanged)

k. For openings between S-2 parking garage and Group R-2 building, see Section 705.3 Exception #2.

Reason: This code proposal attempts to resolve a practical design issue that is extremely common in the design of apartment projects in major urban areas.

The great majority of multi-family projects are being built with parking garages beside the apartment buildings. Access from the parking garage into the apartment unit's floor is provided at each garage floor onto the apartment's floor for convenience as well as for safety for the apartment dwellers. Many designs have one or more of the exterior walls of the parking garage and the apartment building at a 0' fire separation distance. The literal text of the first row of Table 705.8 would prohibit any openings in these exterior walls between the parking garage and the apartment building. However, if these exterior walls were replaced with a fire wall then openings are permitted under Table 705.8 Footnote "c". However, since the parking garage is usually constructed first, and then the apartment building is built next to it, the design and application of a fire wall present major design problems.

The parking garages are usually a minimum of Type I or Type II construction type, whereas the apartment buildings are usually Type III or Type V construction type. The design and tying together two buildings of two different construction types on the same lot is more complicated structurally than designing both buildings with their own exterior walls.

From a life safety/fire protection standpoint, the sprinklered apartment buildings (R-2 use) have one of the best fire safety records of all the occupancies types. The fire history for parking garages shows that most fires are contained to a single vehicle fire.

Since the parking garage and the apartment building are on the same lot there should be no logical reason why opening protectives can not be installed in the exterior walls between these two buildings the same as permitted for openings in a fire wall between two buildings. The only technical reason is that there is no fire door manufacturer that has details on how to install a listed fire door assembly in such walls that would stay in place if one of the exterior walls collapsed. To resolve this dilemma in a reasonable and practical manner, since the apartment building is required to be sprinklered under Section 903.2.8), the fire door assembly would be placed in the exterior wall of the S-2 Parking Garage. If by some chance the R-2 sprinklered building burned to the ground, the openings into the parking garage would still be protected. If by chance the S-2 parking garage burned down to the ground, the sprinklers near the openings in the exterior wall of the R-2 building would provide adequate protection. As mentioned above, based on the past fire history of sprinklered R-2 occupancies and S-2 parking garages the likelihood of either building type burning down to the ground is not very probable.

Cost Impact: Cost savings with no decrease in fire protection or life safety

FS20-12

Public Hearing:	Committee:	AS	AM	D
	Assembly:	ASF	AMF	DF

705.3-FS-KLEIN

FS21 – 12

705.6

Proponent: Dennis Richardson, PE; Building Official, City of Salinas, representing Tri-Chapter of ICC (Peninsula, East Bay and Monterey Bay Chapters of ICC) (dennisrichardsonpe@yahoo.com)

Revise as follows:

705.6 Structural stability. The wall shall extend to the height required by Section 705.11 and all members providing vertical structural support shall have sufficient structural stability such that it will remain in place for the duration of time indicated by the required *fire-resistance rating*. ~~Where exterior walls have a minimum *fire separation distance* of not less than 30 feet (9144 mm), interior structural elements which brace the exterior wall but which are not located within the plane of the exterior wall shall have the minimum *fire-resistance rating* required in Table 601 for that structural element. Structural elements which brace the exterior wall but are located outside of the exterior wall or within the plane of the exterior wall shall have the minimum *fire-resistance rating* required in Tables 601 and 602 for the exterior wall.~~

Reason: Several code authorities including the author of this code change and the previous code change (establishing the 30 feet requirement proposed to be deleted above) have interpreted this code section to be a requirement similar to fire walls that the wall would stay in place after the building collapses from a fire internal to the building.

The IBC code and commentary states "This section on structural integrity for exterior walls does not require that the wall remains in place when the structure collapses. That language is only used for fire wall structural integrity."

Given the language in the code and commentary, this code change would clarify the code language so readers of the code better understand the intent.

Cost Impact: This code change will not increase the cost of construction.

Analysis: FS21 and FS22 provide different requirements for exterior wall structural stability. The committee needs to make its intent clear with respect to these provisions.

FS21-12

Public Hearing:	Committee:	AS	AM	D
	Assembly:	ASF	AMF	DF

705.6-FS-RICHARDSON

FS22 – 12

705.6, 706.2

Proponent: Jonathan Siu, representing City of Seattle Department of Planning & Development (jon.siu@seattle.gov)

Revise as follows:

705.6 Protection required for structural stability. ~~The wall~~ Exterior walls shall extend to the height required by Section 705.11 ~~and shall have sufficient structural stability such that it will remain in place for the duration of time indicated by the required fire-resistance rating.~~ Where exterior walls have a minimum *fire separation distance* of not less than 30 feet (9144 mm), interior structural elements which brace the exterior wall but which are not located within the plane of the exterior wall shall have the minimum *fire-resistance rating* required in Table 601 for that structural element. Structural elements which brace the exterior wall but are located outside of the exterior wall or within the plane of the exterior wall shall have the minimum *fire-resistance rating* required in Tables 601 and 602 for the exterior wall.

706.2 Protection required for structural stability. ~~Fire walls shall have sufficient structural stability under fire conditions to allow collapse of construction on either side without collapse of the wall for the duration of time indicated by the required fire-resistance rating.~~ Structural elements which brace the fire wall but are located outside of the fire wall or within the plane of the fire wall shall have the minimum *fire-resistance rating* required for the fire wall, or the wall shall be constructed as double fire walls in accordance with NFPA 221.

Reason: The purpose of this code change proposal is to delete the requirements that an exterior walls or fire walls must maintain their stability under real fire conditions for a real-time 1, 2, 3, or 4 hours. This is an inappropriate performance standard for the following reasons:

1. This requirement is unenforceable. It is a common misconception that a given fire-resistance rating means the rated assembly will stand for the stated period of time (in real time) under real fire conditions. However, while the test that establishes the rating provides a common standard (or level playing field) for tested assemblies, it does not necessarily represent the behavior of a real wall under real fire conditions. Stated another way, the test is only meant to measure performance in the given test environment, not to reflect real-world conditions. Because the test standard does not tell you how long in real time the assembly will stand under real fire conditions, there is no method for a design professional (or code official) to determine ahead of time how these assemblies should be constructed given the code requirement—nobody will know until a real fire occurs in the building and someone times how long the wall stands (if it collapses) or if it withstands the fire for the required (real-time) time period.
2. These elements (exterior and fire walls) are being held to a much higher standard than any other element, with no justification. That is, no other element is required to remain in place for the required real time under real-world fire conditions, whether they be horizontal assemblies, or fire barriers protecting an interior exit stair, for example. There is no reason why exterior walls and fire walls should be treated differently than these other equally important elements.
3. If the intent of the deleted text is to require exterior and fire walls to meet the required fire resistance rating, then the text is redundant.
4. If the intent of the requirement in these sections is to require a specific structural design, Chapter 16 doesn't provide sufficient guidance for structural design of wall anchorage that would withstand collapse of a portion of a building. In addition, Chapter 7 is an inappropriate location for structural design requirements.

It is to be noted that this proposal does not take away fire protection. Part of the reason why fire-resistant rated construction is required is to protect the structure. The apparent intent of the text being proposed to be deleted is that the stability of the element (exterior or fire wall) matches the required fire-resistance rating of the assembly. However, this intent is covered by the last sentence in Section 705.6 and the added text to 706.2—the floors and roof stabilize the wall, and they are protected to the same degree the walls are. This text is being proposed to be added to Section 706.2 in order to replace the requirement for real-time structural stability, and retain the parallel requirement.

Cost Impact: The code change proposal will not increase the cost of construction.

Analysis: FS21 and FS22 provide different requirements for exterior wall structural stability. The committee needs to make its intent clear with respect to these provisions. FS22 and FS27 provide different requirements for fire wall structural stability. The committee needs to make its intent clear with respect to these provisions.

FS22-12

Public Hearing: Committee: AS AM D

Assembly: ASF AMF DF

705.6-FS-SIU

FS23 – 12
Table 705.8

Proponent: Barry Gupton, PE, NC Department of Insurance, Office of State Fire Marshal, Engineering Division (barry.gupton@ncdoi.gov)

Revise as follows:

TABLE 705.8
MAXIMUM AREA OF EXTERIOR WALL OPENINGS BASED ON
FIRE SEPARATION DISTANCE AND DEGREE OF OPENING PROTECTION

FIRE SEPARATION DISTANCE (feet)	DEGREE OF OPENING PROTECTION	ALLOWABLE AREA^a
30 or greater	Unprotected, Nonsprinklered (UP, NS)	No Limit
	Unprotected, Sprinklered (UP, S) ⁱ	Not Required <u>No Limit</u>
	Protected (P)	Not Required <u>No Limit</u>

(Portions of table not shown remain unchanged)

Reason The current wording incorrectly indicates that for Unprotected, Sprinklered and Protected openings which have a fire separation distance of 30' or greater are "Not Required". Actually the areas of these openings are unlimited for these situations except where Note i applies.

Cost Impact: The code change proposal will not increase the cost of construction.

FS23-12

Public Hearing: Committee: AS AM D
 Assembly: ASF AMF DF

T705.8-FS-GUPTON

FS24 – 12

705.8.5

Proponent: Steve Pfeiffer representing City of Seattle, Dept of Planning & Development
(steve.pfeiffer@seattle.gov)

Revise as follows:

705.8.5 Vertical separation of openings. Openings in *exterior walls* in adjacent *stories* shall be separated vertically to protect against fire spread on the exterior of the buildings where the openings are within 5 feet (1524 mm) of each other horizontally and the opening in the lower *story* is not a protected opening with a *fire protection rating* of not less than 3/4 hour. Such openings shall be separated vertically at least 3 feet (914 mm) by spandrel girders, *exterior walls* or other similar assemblies that have a *fire-resistance rating* of at least 1 hour, rated for exposure to fire from both sides, or by flame barriers that extend horizontally at least 30 inches (762 mm) beyond the *exterior wall*. Flame barriers shall also have a *fire-resistance rating* of at least 1 hour. The unexposed surface temperature limitations specified in ASTM E 119 or UL 263 shall not apply to the flame barriers or vertical separation unless otherwise required by the provisions of this code.

Exceptions:

1. This section shall not apply to buildings that are three *stories* or less above *grade plane*.
2. This section shall not apply to buildings equipped throughout with an *automatic sprinkler system* in accordance with Section 903.3.1.1 or 903.3.1.2.
3. Open parking garages.

Reason: This change is intended to clarify that provisions of Section 705.5, requiring an exterior wall with a fire separation distance of greater than 10 feet to only consider exposure to a fire from the inside, do not apply to Section 705.8.5. Fire separation distance, the critical factor in Section 705.5, to prevent spread of fire from property to property or building to building, plays no role in Section 705.8.5. The hazard, in Section 705.8.5, is of a fire within the building moving from floor to floor via exterior wall openings. It is critical that where a fire-resistive rated spandrel is used in prevention of the spread of fire from floor to floor, the assumed exposure to fire be from both sides of the wall spandrel.

Cost Impact: The code change proposal will not increase the cost of construction.

FS24-12

Public Hearing:	Committee:	AS	AM	D
	Assembly:	ASF	AMF	DF

705.8.5-FS-PFEIFFER

FS25 – 12

705.8.5

Proponent: Tony Crimi, A.C. Consulting Solutions Inc, representing North American Insulation Manufacturers Association (NAIMA) (tcrimi@sympatico.ca)

Revise as follows:

705.8.5 Vertical separation of openings. Openings in *exterior walls* in adjacent *stories* shall be separated vertically to protect against fire spread on the exterior of the buildings where the openings are within 5 feet (1524 mm) of each other horizontally and the opening in the lower *story* is not a protected opening with a *fire protection rating* of not less than 3/4 hour. Such openings shall be separated vertically at least 3 feet (914 mm) by spandrel girders, *exterior walls* or other similar assemblies that have a *fire-resistance rating* of at least 1 hour or by flame barriers that extend horizontally at least 30 inches (762 mm) beyond the *exterior wall*. Flame barriers shall also have a *fire-resistance rating* of at least 1 hour. The unexposed surface temperature limitations specified in ASTM E 119 or UL 263 shall not apply to the flame barriers or vertical separation unless otherwise required by the provisions of this code.

Exceptions:

1. This section shall not apply to buildings that are three *stories* or less above *grade plane*.
2. This section shall not apply to buildings equipped throughout with an *automatic sprinkler system* in accordance with Section 903.3.1.1 or 903.3.1.2.
3. Open parking garages.
4. Perimeter fire containment systems tested in accordance with ASTM E 2XXX to provide an *F rating* for a time period at least equal to the *fire-resistance rating* of the floor assembly are permitted.

Add new standard to Chapter 35 as follows:

ASTM
E2XXX- Standard Test Method for Determining the Fire Resistance of Building Perimeter Containment Systems Due to External Spread of Fire

Reason: This proposal adds an additional alternative to the current IBC requirements for separation of openings in exterior walls. ASTM is currently working on the development of a Standard entitled "*Standard Test Method for Determining the Fire Resistance of Building Perimeter Containment Systems Due to External Spread of Fire*".

Justification: The new ASTM "leap-frog" standard is designed to evaluate the fire performance of an exterior wall assembly, with or without glazing, to prevent the spread of fire to the interior of the room above via fire spread from the exterior of a building by evaluating the building perimeter containment system, which includes the exterior curtain wall assembly and any glazing. The buildings perimeter containment system is a unique building construction detail not addressed by other fire test methods.

This test method is intended to simulate a possible fire exposure due to a post flashover compartment fire venting through an opening, onto the exterior building perimeter containment system. The fire exposure conditions in the test room are those specified by this test method for the first 30 min of exposure and then conform to the Test Methods E 119 time-temperature curve for the remainder of the test. This test method specifies the heating conditions, methods of test, and criteria for evaluation of the building perimeter containment system. Test results establish the performance of the perimeter containment system during the fire-exposure period and shall not be construed as having determined the suitability of a perimeter containment system for use after that exposure.

This test method evaluates the building perimeter containment system's ability to impede vertical fire spread to the interior of the room above via fire spread on the exterior of a building. In contrast, ASTM E2307 evaluates the ability of the perimeter fire barrier system to impede the vertical spread of fire from the floor of origin to the floor(s) above, via an interior fire spread.

Cost Impact: This proposal does not increase the cost of construction.

Analysis: A review of the standard proposed for inclusion in the code, ASTM E2XXX with regard to the ICC criteria for referenced standards (Section 3.6 of CP#28) will be posted on the ICC website on or before April 2, 2012.

FS25-12

Public Hearing:	Committee:	AS	AM	D
	Assembly:	ASF	AMF	DF

705.8.5-FS-CRIMI

FS26 – 12

705.8.6, 705.8.6.1 (New), 705.8.6.2 (New)

Proponent: Homer Maiel, PE, CBO, Town of Atherton, representing self.

Revise as follows:

705.8.6 Vertical exposure. Opening protectives of buildings shall comply with this section.

705.8.6.1 Vertical exposure for buildings on the same lot. For buildings on the same lot, opening protectives having a *fire protection rating* of not less than 3/4 hour shall be provided in every opening that is less than 15 feet (4572 mm) vertically above the roof of an adjacent building or structure based on assuming an imaginary line between them. The opening protectives are required where the *fire separation distance* between the imaginary line and the adjacent building or structure is less than 15 feet (4572 mm).

Exceptions:

1. Opening protectives are not required where the roof assembly of the adjacent building or structure has a *fire-resistance rating* of not less than 1 hour for a minimum distance of 10 feet (3048 mm) from the *exterior wall* facing the imaginary line and the entire length and span of the supporting elements for the fire-resistance-rated roof assembly has a *fire-resistance rating* of not less than 1 hour.
2. Buildings on the same lot and considered as portions of one building in accordance with Section 705.3 are not required to comply with Section 705.8.6.1.

705.8.6.2 Vertical exposure for buildings on separate lots. When a new building or an addition is to be erected adjacent to an existing building, all openings in the exterior wall of the new building or addition are required to be not less than 3/4 hour protectives when these openings are less than 15' vertically above the roof of existing building or structure. The opening protections are required where the distance between buildings or structures is less than 15' feet. When the roof of the new building or an addition is at lower elevation from the existing building, the roof construction of the new building or the addition shall have fire-resistance rating of not less than 1 hour for a minimum distance of 10 feet (3048 mm) from the exterior wall facing the existing building and the entire length and span of the supporting elements for the fire-resistance-rated roof assembly shall have a fire-resistance rating of not less than 1 hour. The roof protections are required where the distance between the buildings or structures is less than 15' feet.

Reason: A fire in a lower building that is adjacent to a taller building can be a source of fire exposure to openings in the taller building. Since fire does not differentiate between buildings on same lot or separate adjacent lots, the existing provisions for buildings on the same lot need to be expanded to cover buildings on separate lots too. The requirements for the buildings on the separate lots should not be different from those on the same lot. The buildings on the same lots are under one ownership and the imaginary property lines can be moved so that it will serve all buildings in the most efficient way.

On the other hand, the buildings on separate lots are under different ownerships. The property lines are legal property lines and can not be moved around. An existing building on one site should not dictate the design and construction of the future building nor a future building should not alter the design and construction of an existing building. In other words, between two neighboring buildings, whichever is built last will need to comply with requirements of this section. The 15-foot separation requirement between buildings on the separate lots, is consistent with the same requirement for buildings on the same lot.

Also not to leave out the additions to existing buildings, additions are also included in these requirements. So for the sake of argument, imagine that there are two existing buildings, with same height, on separate lots. If one building is adding more stories, then these requirements could apply to the windows of new stories.

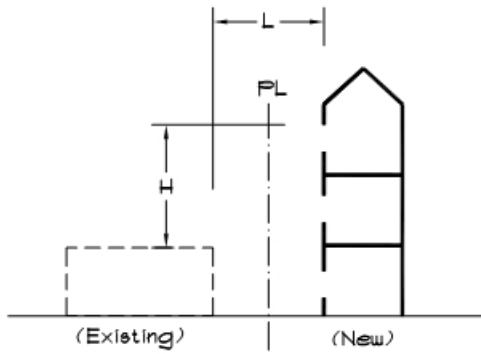

Fig. 1

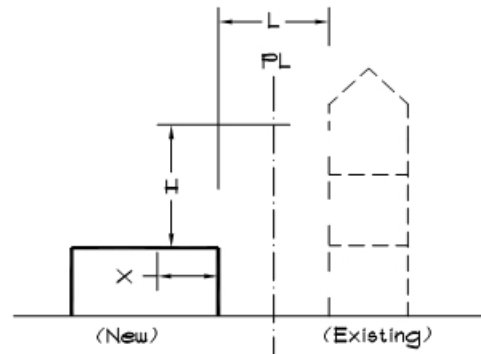

Fig. 2

— New Construction
 --- Existing Const.

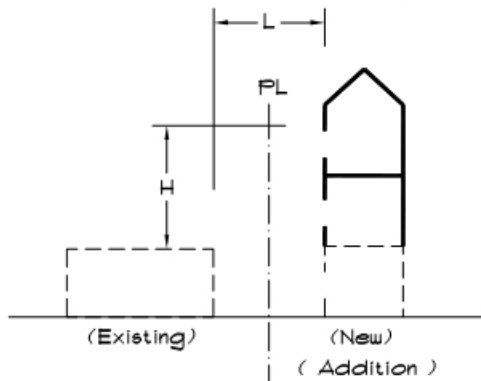

Fig. 3

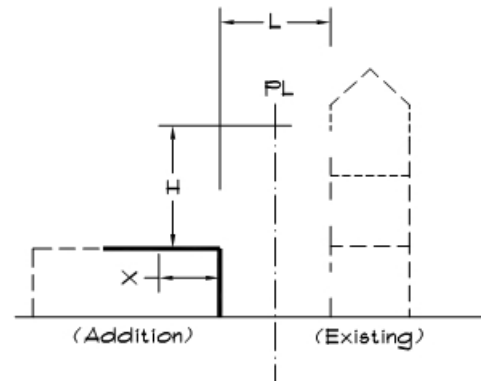

Fig. 4

Cost Impact: The code change proposal will not increase the cost of construction.

FS26-12

Public Hearing: Committee: AS AM D
 Assembly: ASF AMF DF

705.8.6-FS-MAIEL

FS27 – 12

706.2

Proponent: Edwin Huston represents National Council of Structural Engineers Associations- Code Advisory Committee - General Requirements Subcommittee (huston@smithhustoninc.com)

Revise as follows:

706.2 Structural stability. Firewalls shall be designed to meet the requirements of Chapter 16 under non-fire conditions. Fire walls shall be designed to have sufficient structural stability under fire conditions to allow collapse of construction on either side without collapse of the wall for a lateral design wind load of 8 lb/ft² for the duration of time indicated by the required fire-resistance rating or shall be constructed as double fire walls in accordance with NFPA 221.

Reason: Section 706.2 is proposed for revision to provide a standard set of structural design requirements. Chapter 16 has requirements for structural walls, so a pointer to Chapter 16 is proposed. Without a specified wind design force, different jurisdictions have suggested different loading requirements to structural engineers. The 8 psf proposed is the current design load for interior partitions. It is the 5 psf load which has been used for many code cycles updated to a strength level load to agree with ASCE 7-10.

Cost Impact: The code change proposal will not increase the cost of construction.

Analysis: FS22 and FS27 provide different requirements for fire wall structural stability. The committee needs to make its intent clear with respect to these provisions.

FS27-12

Public Hearing:	Committee:	AS	AM	D
	Assembly:	ASF	AMF	DF

706.2-FS-HUSTON

FS28 – 12

707.5, 707.5.1

Proponent: Philip Brazil, Reid Middleton, Inc., representing Washington Association of Building Officials, Technical Code Development Committee (pbrazil@reidmiddleton.com)

Revise as follows:

707.5 Continuity. *Fire barriers* shall extend from the top of the foundation or floor/ceiling assembly below to the underside of the floor or roof sheathing, slab or deck above and shall be securely attached thereto. Such *fire barriers* shall be continuous through concealed space, such as the space above a suspended ceiling. Joints and voids at intersections shall comply with Sections 707.8 and 707.9.

Exceptions:

1. Shaft enclosures shall be permitted to terminate at a top enclosure complying with Section 713.12.
2. Interior exit stairway and ramp enclosures required by Section 1022.2 and exit access stairway and ramp enclosures required by Section 1009.3 shall be permitted to terminate at a top enclosure complying with Section 713.12.

707.5.1 Supporting construction. The supporting construction for a *fire barrier* shall be protected to afford the required *fire-resistance rating* of the *fire barrier* supported. Hollow vertical spaces within a *fire barrier* shall be fireblocked in accordance with Section 718.2 at every floor level.

Exceptions:

1. The maximum required *fire-resistance rating* for assemblies supporting *fire barriers* separating tank storage as provided for in Section 415.8.2.1 shall be 2 hours, but not less than required by Table 601 for the building construction type.
- ~~2. Shaft enclosures shall be permitted to terminate at a top enclosure complying with Section 713.12.~~
2. Supporting construction for 1-hour *fire barriers* required by Table 509 in buildings of Type IIB, IIIB and VB construction is not required to be fire-resistance rated unless required by other sections of this code.
4. ~~Interior exit stairway and ramp enclosures required by Section 1022.2 and exit access stairway and ramp enclosures required by Section 1009.3 shall be permitted to terminate at a top enclosure complying with Section 713.12.~~

Reason: Exception 2 of Section 707.5.1 has been in the IBC since the 2000 edition (Section 706.5 for fire barriers) and, until the 2009 edition, had applied to the requirements in Sections 707.5 and 707.5.1, which were in a single Section 706.5 on continuity. Exception 2 of Section 706.5 in the 2006 edition (Section 706.4 in the 2000 and 2003 editions) is intended to apply to Section 707.5 of the 2009 and 2012 editions, which requires fire barriers to extend to the top of the underside of the floor or roof sheathing, slab or deck above. Proposal FS37-07/08-AMPC created a separate Section 707.5.1, which led to the incorrect placement of the exception in Section 707.5.1. Exception 4 of Section 707.5.1 is also relocated to Section 707.5 because the subject of the exception is similar to that of Exception 2.

Cost Impact: The code change proposal will not increase the cost of construction.

FS28-12

Public Hearing:	Committee:	AS	AM	D
	Assembly:	ASF	AMF	DF

707.5-FS-BRAZIL

FS29 – 12

707.6, 707.7.1, 717.5.2

Proponent: Philip Brazil, Reid Middleton, Inc., representing Washington Association of Building Officials, Technical Code Development Committee (pbrazil@reidmiddleton.com)

Revise as follows:

707.6 Openings. Openings in a *fire barrier* shall be protected in accordance with Section 716. Openings shall be limited to a maximum aggregate width of 25 percent of the length of the wall, and the maximum area of any single opening shall not exceed 156 square feet (15 m²). Openings in enclosures for exit access stairways and ramps, interior exit stairways and ramps, and exit passageways shall also comply with Sections ~~1009.3.1.4, 1022.3~~ 1022.4 and 1023.5, respectively.

(No change to Exceptions)

707.7.1 Prohibited penetrations. Penetrations into enclosures for ~~exit access stairways, exit access and ramps, interior exit stairways, interior exit and ramps, or an and exit passageways~~ shall be allowed only ~~when~~ where permitted by Sections ~~1009.3.1.5, 1022.5 or and~~ 1023.6, respectively.

717.5.2 Fire barriers. Ducts and air transfer openings of *fire barriers* shall be protected with *approved fire dampers* installed in accordance with their listing. Ducts and air transfer openings shall not penetrate enclosures for ~~interior exit stairways, and ramps, and exit passageways,~~ except as permitted by Sections ~~1022.4~~ 1022.5 and 1023.6, respectively.

(No change to Exceptions)

Reason: In Section 707.6, the addition of Section 1009.3.1.4 eliminates a technical error in that Proposal E5-09/10-AS expanded the scope of 2009 IBC Section 707.6 from exit enclosures and exit passageways to also include exit access stairways and exit access ramps. Section 1009.3.1.4 in the 2012 IBC corresponds to exit access stairways and exit access ramps in the same manner as Sections 1022.3 and 1023.5 correspond to exit enclosures and exit passageways, respectively, in the 2009 IBC. With the addition of Section 1009.3.1.4 in the proposal, the egress components are effectively placed into three groups so that they correspond to the three referenced sections. The change in the section reference from 1022.3 to 1022.4 restores the correlation in 2009 IBC Section 707.6 that referenced Section 1022.3 for openings, which is Section 1022.4 in the 2012 IBC.

The changes in Section 707.7.1 are primarily clarifying. The deletion of “exit access” and “interior exit” is done for consistency with “exit access stairways and ramps” and “interior exit stairways and ramps” in Section 707.6 and elsewhere in the 2012 IBC as established with the approved changes from Proposal E5-09/10-AS. The changes from “or” to “and” eliminate a technical error in that 2009 Section 707.7.1 contains two items and two corresponding section references but Proposal E5-09/10-AS revised the section to include five items and three section references, which do not correspond in the same manner. The additions in the proposal effectively place the egress components into three groups so that they correspond to the three referenced sections.

In Section 717.5.2, “interior exit” is added because Proposal E5-09/10-AS replaced “exit enclosures and exit passageways” with “enclosures for stairways, ramps and exit passageways” but exit access stairways and exit access ramps are required to be enclosed in accordance with Sections 1009.3 and 1010.2, respectively, and Sections 1022.5 and 1023.6 are limited in scope to interior exit stairways and ramps, and exit passageways, respectively. Without the addition of “interior exit,” Section 717.5.2 would be more restrictive for exit access stairways and ramps than for interior exit stairways and ramps because of the penetrations of interior exit stairways and ramps, and exit passageways, by ducts and air transfer openings that are permitted by Sections 1022.5 and 1023.6, respectively, unless otherwise prohibited by Section 717.5.2. Note that 2012 IBC Section 1009.3.1.7 does not impose additional requirements on penetrations of exit access stairway enclosures other than by reference to Section 717. The change in the section reference from 1022.4 to 1022.5 restores the correlation in 2009 IBC Section 716.5.2 that referenced Section 1022.4 for penetrations, which is Section 1022.5 in the 2012 IBC.

Cost Impact: The code change proposal will not increase the cost of construction.

FS29-12

Public Hearing:	Committee:	AS	AM	D
	Assembly:	ASF	AMF	DF

707.6-FS-BRAZIL

FS30 – 12

707.9

Proponent: Tim Pate, City and County of Broomfield, Colorado, representing Colorado Chapter Code Change Committee

Revise as follows:

707.9 Voids at intersections. The voids created at the intersection of a *fire barrier* and a non-fire-resistance-rated roof assembly or a non-fire-resistance – rated exterior wall assembly shall be filled. An approved material or system shall be used to fill the void, shall be securely installed in or on the intersection for its entire length so as not to dislodge, loosen or otherwise impair its ability to accommodate expected building movements and to retard the passage of fire and hot gases.

Reason: Section 707.9 is a new code section that deals with how to treat voids at top of fire barriers which terminate at non fire resistance rated roof assemblies. There is the same issue where fire barriers terminate at non fire resistance rated exterior walls. The added code language will clear up what to do with the void at these exterior walls which will match what to do at roof assembly.

Cost Impact:

FS30-12

Public Hearing:	Committee:	AS	AM	D
	Assembly:	ASF	AMF	DF

707.9-FS-PATE

FS31 – 12

707.9, 715.6 (New), 715.6.1 (New), Chapter 35

Proponent: Tony Crimi, A.C. Consulting Solutions Inc, representing International Firestop Council (tcrimi@sympatico.ca)

Revise as follows:

707.9 Voids at intersections. The voids created at the intersection of a *fire barrier* and a non-fire-resistance-rated roof assembly shall ~~comply with Section 715. be filled. An approved material or system shall be used to fill the void, shall be securely installed in or on the intersection for its entire length so as not to dislodge, loosen or otherwise impair its ability to accommodate expected building movements and to retard the passage of fire and hot gases.~~

715.6 Joints between fire resistance rated walls and non-fire resistance rated Floors or Roofs. Joints at the intersection of *fire barriers* with the underside of a non-fire resistance rated floor or roof sheathing, slab or deck above shall be protected by an approved continuity head of wall joint system installed as tested in accordance with ASTM E2837 and designed to resist the passage of fire for a time period not less than the required fire resistance rating of the wall in which it is installed.

715.6.1 Installation. Continuity head of wall joint systems shall be securely installed in or on the joint for its entire length so as not to dislodge, loosen or otherwise impair its ability to accommodate expected building movements and to retard the passage of fire and hot gases.

(Renumber subsequent section)

Add new standard to Chapter 35 as follows:

ASTM E 2837-11 *Standard Test Method for Determining the Fire Resistance of Continuity Head-of-Wall Joint Systems Installed between Rated Wall Assemblies and Nonrated Horizontal Assemblies.*

Reason: Chapter 7 of the IBC has numerous requirements for continuity of vertical and horizontal assemblies. In 2011 ASTM published its new ASTM Standard Test Method for Determining the Fire Resistance of Continuity Head-of-Wall Joint Systems Installed between Rated Wall Assemblies and Nonrated Horizontal Assemblies, ASTM E 2837-11. Referencing this Standard will help code enforcers and manufacturers by alleviate the need to use Engineering Judgements for many of these conditions.

Wall continuity is required by the IBC at joint openings, which are typically linear voids, gaps, openings, or other discontinuities within or at the junction of a rated wall assembly and nonrated horizontal assemblies, to ensure that the protected joint opening has the same fire resistance rating as the rated wall assembly and provides continuity to the underside of the roof, slab or deck.

Section 707.9 of the IBC requires the joint opening at the termination at the top of the rated fire barrier wall assembly below the nonrated horizontal assembly to be protected. The new ASTM E 2837 Standard evaluates continuity head-of-wall joint systems for this specific application. They are used in order to maintain continuity established by the rated wall assembly.

A continuity head-of-wall joint system is particular type of fire-resistive joint system that provides fire resistance to prevent passage of fire from compartment to compartment within the building at the joint opening between a rated wall assembly and a nonrated horizontal assembly. A continuity head-of-wall joint system is a unique building construction detail not addressed by other fire test methods such as Test Method E 1966 that tests joint systems installed between two assemblies that are fire resistance rated.

To achieve the F-Rating, the joint system must remains in the opening during the fire resistance test and the hose stream test, and will have withstood the fire resistance test for the rating period equal to the rated wall assembly by preventing flaming on the unexposed side of the test specimen and on the underside of the nonrated horizontal assembly on the unexposed side. The Integrity test also ensures no occurrence of ignition of the cotton pad, which is related to the passage of hot gases in the current IBC 707.9 requirements.

Cost Impact: This proposal should reduce affect the cost of construction

Analysis: FS31 and FS32 provide different requirements for the same joint condition (715.6). The committee needs to make its intent clear with respect to these provisions. A review of the standard proposed for inclusion in the code, ASTM E2837-11 with regard to the ICC criteria for referenced standards (Section 3.6 of CP#28) will be posted on the ICC website on or before April 2, 2012.

FS31-12

Public Hearing:	Committee:	AS	AM	D
	Assembly:	ASF	AMF	DF

707.9 #1-FS-CRIMI

FS32 – 12

707.9, 715.6 (New), Chapter 35

Proponent: John Valiulis, representing Hilti, Inc.(john.valiulis@hilti.com)

Revise as follows:

707.9 Voids at intersections. The voids created at the intersection of a *fire barrier* and a non-fire-resistance-rated roof assembly shall ~~comply with Section 715. be filled. An approved material or system shall be used to fill the void, shall be securely installed in or on the intersection for its entire length so as not to dislodge, loosen or otherwise impair its ability to accommodate expected building movements and to retard the passage of fire and hot gases.~~

715.6 Fire-Resistance rated wall/nonfire-resistance-rated floor or roof assembly intersections. The voids created at the intersection of a fire-resistance rated vertical wall assembly and a non-fire-resistance-rated floor or roof assembly shall be installed and tested in accordance with ASTM E 2837 to prevent the passage of flame for the time period at least equal to the *fire-resistance rating* of the wall assembly and prevent the passage of heat and hot gases sufficient to ignite cotton waste.

Add new standard to Chapter 35 as follows:

ASTM E 2837-11 *Standard Test Method for Determining the Fire Resistance of Continuity Head-of-Wall Joint Systems Installed between Rated Wall Assemblies and Nonrated Horizontal Assemblies.*

Reason: Chapter 7 of the IBC has numerous requirements for continuity of vertical and horizontal assemblies. Wall continuity is required at joint openings, which are typically linear voids, gaps, openings, or other discontinuities within or intersecting rated wall assembly and nonrated horizontal assemblies, to ensure that the protected joint opening has the same fire resistance rating as the rated wall assembly. In 2011 ASTM published its new ASTM Standard Test Method for Determining the Fire Resistance of Continuity Head-of-Wall Joint Systems Installed between Rated Wall Assemblies and Nonrated Horizontal Assemblies, ASTM E 2837-11.

Section 707.9 of the IBC already requires the joint opening at the termination at the top of the rated fire barrier wall assembly below the nonrated horizontal assembly to be protected. The new ASTM E 2837 Standard evaluates continuity head-of-wall joint systems for this specific application. They are used in order to maintain continuity established by the rated wall assembly.

A continuity head-of-wall joint system is particular type of fire-resistive joint system that provides fire resistance to prevent passage of fire from compartment to compartment within the building at the joint opening between a rated wall assembly and a nonrated horizontal assembly. A continuity head-of-wall joint system is a unique building construction detail not addressed by other fire test methods such as Test Method E 1966 that tests joint systems installed between two assemblies that are fire resistance rated.

To achieve the F-Rating, the joint system must remains in the opening during the fire resistance test and the hose stream test, and will have withstood the fire resistance test for the rating period equal to the rated wall assembly by preventing flaming on the unexposed side of the test specimen and on the underside of the nonrated horizontal assembly on the unexposed side. The Integrity test also ensures no occurrence of ignition of the cotton pad, which is related to the passage of hot gases in the current IBC 707.9 requirements.

Cost Impact: This code change will not increase the cost of construction.

Analysis: FS31 and FS32 provide different requirements for the same joint condition (715.6). The committee needs to make its intent clear with respect to these provisions. A review of the standard proposed for inclusion in the code, ASTM E2837-11 with regard to the ICC criteria for referenced standards (Section 3.6 of CP#28) will be posted on the ICC website on or before April 2, 2012.

FS32-12

Public Hearing:	Committee:	AS	AM	D
	Assembly:	ASF	AMF	DF

707.9-FS-VALIULIS

FS33 – 12

707.9

Proponent: Tony Crimi, A.C. Consulting Solutions Inc, representing International Firestop Council (tcrimi@sympatico.ca)

Revise as follows:

~~**707.9 Voids at intersections.** The voids created at the intersection of a *fire barrier* and a non-fire-resistance-rated roof assembly shall be filled. An approved material or system shall be used to fill the void, shall be securely installed in or on the intersection for its entire length so as not to dislodge, loosen or otherwise impair its ability to accommodate expected building movements and to retard the passage of fire and hot gases.~~

Reason: This language is redundant. Section 707.8 already addresses this condition, and there is no difference between a "Void created at intersections" and Joints, which are defined as "The opening in or between adjacent assemblies...".

In the previous cycle, a Code change proposal was approved to 707.8 which clarified that the same requirement to protect the joint between a fire barrier and the underside of the floor also applies to the joint between a fire barrier and an exterior wall. The language in the 2012 IBC points the user to compliance with section 715. It is similar to the language in other sections of the IBC for voids created between rated and unrated assemblies.

Cost Impact: This code change will not increase the cost of construction.

Analysis: FS30 through FS32 provide revisions to Section 707.9. FS33 proposes deletion of the requirements. The committee needs to make its intent clear with respect to these provisions.

FS33-12

Public Hearing:	Committee:	AS	AM	D
	Assembly:	ASF	AMF	DF

707.9 #2-FS-CRIMI

FS34 – 12

708.1, 711.3

Proponent: Lee J. Kranz, City of Bellevue, WA, representing Washington Association of Building Officials Technical Code Development (lkranz@bellevuewa.gov)

Revise as follows:

SECTION 708 FIRE PARTITIONS

708.1 General. The following wall assemblies shall comply with this section.

- ~~1. Walls separating dwelling units in the same building as required by Section 420.2.~~
- ~~2. Walls separating sleeping units in the same building as required by Section 420.2.~~
1. Separation walls as required by Section 420.2 for Group I-1, R-1, R-2 and R-3.
- ~~32. Walls separating tenant spaces in covered and open mall buildings as required by Section 402.4.2.1.~~
43. Corridor walls as required by Section 1018.1.
- ~~54. Elevator lobby separation as required by Section 713.14.1.~~

SECTION 711 HORIZONTAL ASSEMBLIES

711.3 Fire-resistance rating. The *fire-resistance rating* of floor and roof assemblies shall not be less than that required by the building type of construction. Where the floor assembly separates mixed occupancies, the assembly shall have a *fire-resistance rating* of not less than that required by Section 508.4 based on the occupancies being separated. Where the floor assembly separates a single occupancy into different *fire areas*, the assembly shall have a *fire-resistance rating* of not less than that required by Section 707.3.10. ~~Horizontal assemblies separating dwelling units in the same building and horizontal assemblies separating sleeping units in the same building shall be a minimum of 1-hour fire-resistance-rated construction.~~ Horizontal assemblies serving as dwelling or sleeping unit separations in accordance Section 420.3 shall be a minimum of 1-hour fire-resistance rated construction.

Exception: *Dwelling unit* and *sleeping unit* separations in buildings of Type IIB, IIIB and VB construction shall have *fire-resistance ratings* of not less than ½ hour in buildings equipped throughout with an approved *automatic sprinkler system* in accordance with Section 903.3.1.1.

Reason: This proposal creates consistency of Sections 708.1 and 711.3 with Sections 420.2 and 420.3 related to minimum fire resistance rating of vertical and horizontal assemblies.

This proposal creates consistency of Sections 708.1 and 711.3 with Sections 420.2 and 420.3 related to inclusion of "separation required for other occupancies contiguous to sleeping units and dwelling units in the same building".

Cost Impact: This code change proposal will not increase the cost of construction.

FS34-12

Public Hearing:	Committee:	AS	AM	D
	Assembly:	ASF	AMF	DF

708.1-FS-KRANZ

FS35 – 12

709.1

Proponent: Tony Crimi, A.C. Consulting Solutions Inc, representing International Firestop Council (tcrimi@sympatico.ca)

Revise as follows:

709.1 General. Vertical and horizontal *smoke barriers* shall comply with this section.

Reason: The purpose of this proposal is simply to clarify smoke barriers can be either horizontal or vertical. The issue has come up many times, and causes much confusion in the field. The definition of smoke barriers does currently identify that a smoke barrier is a continuous membrane, either vertical or horizontal. The definition goes on to list items such as a wall, floor or ceiling assembly, that is designed and constructed to restrict the movement of smoke.

Cost Impact: This change will reduce the cost of construction.

FS35-12

Public Hearing:	Committee:	AS	AM	D
	Assembly:	ASF	AMF	DF

709.1-FS-CRIMI

FS36 – 12

709.4

Proponent: Tim Pate, City and County of Broomfield, Colorado, representing self

Revise as follows:

709.4 Continuity. *Smoke barriers* shall form an effective membrane continuous from outside wall to outside wall and from the top of the foundation or floor/ceiling assembly below to the underside of the floor or roof sheathing, deck or slab above, including continuity through concealed spaces, such as those found above suspended ceilings, and interstitial structural and mechanical spaces. The supporting construction shall be protected to afford the required *fire-resistance rating* of the wall or floor supported in buildings of other than Type IIB, IIIB or VB construction.

Exceptions:

1. Smoke-barrier walls are not required in interstitial spaces where such spaces are designed and constructed with ceilings or exterior walls that provide resistance to the passage of fire and smoke equivalent to that provided by the smoke-barrier walls.
2. Smoke barriers used for elevator lobbies in accordance with Section 405.4.3, 3007.4.2 or 008.11.2 are not required to extend from outside wall to outside wall.
3. Smoke barriers used for areas of refuge in accordance with Section 1007.6.2 are not required to extend from outside wall to outside wall.

Reason: This added wording will clarify that when a smoke barrier extends to an exterior wall, the interstitial space will be required to provide resistance to the passage of fire and smoke equivalent to that provided by the smoke barrier which will match the requirement at an intersection of a ceiling.

Cost Impact: No cost increase – this proposal is attempting to clarify existing requirements by this added language.

FS36-12

Public Hearing:	Committee:	AS	AM	D
	Assembly:	ASF	AMF	DF

709.4-FS-PATE

FS37 – 12

709.4

Proponent: Carl Baldassarra, P.E., FSFPE, Chair, ICC Code Technology Committee

Revise as follows:

709.4 Continuity. *Smoke barriers* shall form an effective membrane continuous from outside wall to outside wall and from the top of the foundation or floor/ceiling assembly below to the underside of the floor or roof sheathing, deck or slab above, including continuity through concealed spaces, such as those found above suspended ceilings, and interstitial structural and mechanical spaces. The supporting construction shall be protected to afford the required *fire-resistance rating* of the wall or floor supported in buildings of other than Type IIB, IIIB or VB construction.

Exceptions:

1. Smoke-barrier walls are not required in interstitial spaces where such spaces are designed and constructed with ceilings that provide resistance to the passage of fire and smoke equivalent to that provided by the smoke-barrier walls.
2. Smoke barriers used for to enclose elevator lobbies in accordance with Section 405.4.3, 1007.6.2, 3007.7.2 or 3008.7.2 shall be permitted to terminate at the elevator hoistway shaft enclosure. not required to extend from outside wall to outside wall. A smoke and draft control door assembly as specified in Section 716.5.3.1 shall not be required at each elevator hoistway door opening.
3. Smoke barriers used for areas of refuge in accordance with Section 1007.6.2 are not required to extend from outside wall to outside wall.

Reason: This proposal is one of several proposals submitted by the CTC dealing with elevator lobbies. The ICC Executive Board directed the Code Technology Committee (CTC) to study the issue of elevator lobby separations in November 2010 due to the number of code change proposals submitted addressing this issue over a number of code change cycles. The Code Technology Committee formed a study group on the elevator lobby separation issue in December 2010. Note that this subject had been previously addressed by CABO/BCMC in 1986 with a similar conclusion. The code change proposals submitted are the result of the CTC's study of the issue. Note that the scope of the activity was as follows:

Scope

- Review the need for elevator lobbies, with emphasis on building use, building and hoistway height, active and passive fire protection features associated with the aforementioned.
- Review the differences and specific needs when dealing with elevator lobbies of traditional-use elevators, fire service elevators, and occupant evacuation elevators.
- Review related code provisions, such as egress from and through elevator lobbies.
- Review the appropriate use of alternatives including pressurization of hoistways, additional doors, roll-down style barriers, and gasketing systems.
- Review with members of elevator industry to scope the requirements of applicable elevator reference standards as it deals with elevator lobby design, use and construction.
- Review design and construction requirements for elevator lobbies, including but not limited to dimensions, location and separation.
- Review applicable code change history, technical studies and loss statistics as part of this review.

Based upon the extensive nature of this area of study, 5 Task Groups were formed during the process to provide in-depth review and to manage the number of issues. These task groups developed a number of proposals that were coordinated throughout the process.

More information on this CTC area of study can be found at the following link.
<http://www.iccsafe.org/cs/CTC/Pages/ElevatorLobbies.aspx>

This proposal provides clarification of the smoke barrier continuity requirements. Provisions are necessary to clarify that opening protection at the hoistway opening is not necessary when an enclosed elevator lobby is provided in accordance with Section 405.4.3, 3007.7.2, or 3008.7.2. An enclosed elevator lobby protects the hoistway from smoke migration, therefore the hoistway is already protected. In addition the shaft walls provide sufficient smoke and draft protection to allow the smoke barriers to terminate at those walls.

This proposal does not require correlation with other CTC Elevator Lobby SG lobby proposals. See discussion on CTC elevator lobby proposal coordination in code change FS##-12

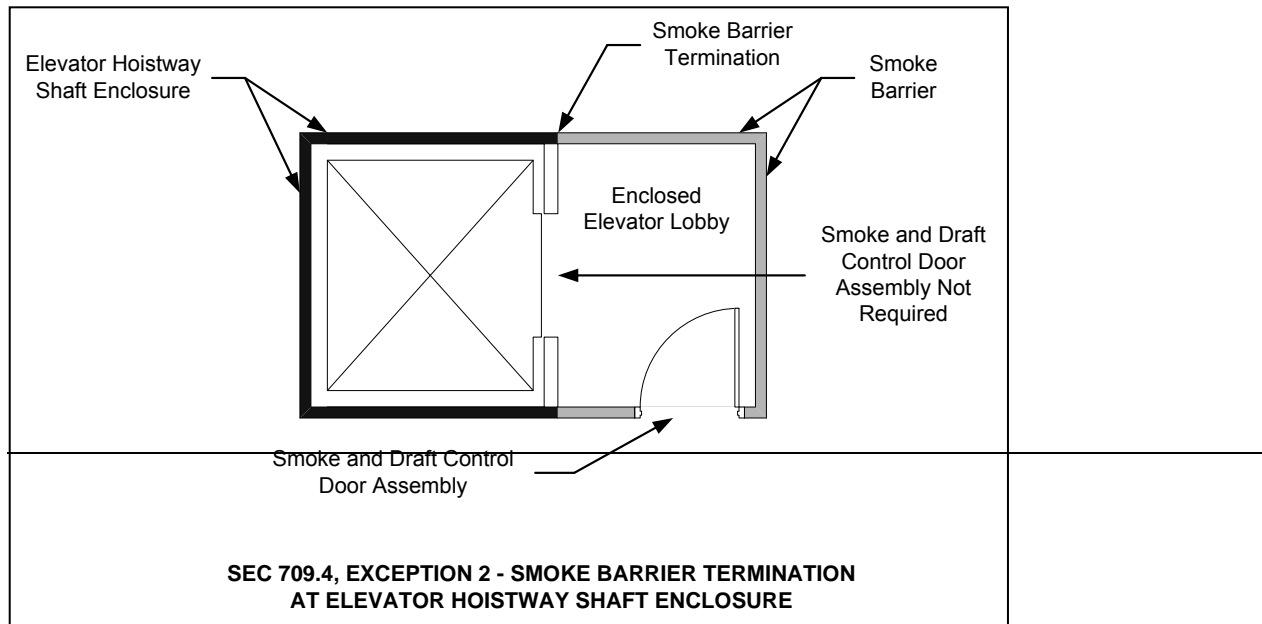

Cost Impact: This code change proposal will not increase the cost of construction.

Analysis: FS37, FS38 and FS39 provide different requirements for smoke barriers enclosing elevator lobbies. The committee needs to make its intent clear with respect to these provisions.

FS37-12

Public Hearing:	Committee:	AS	AM	D
	Assembly:	ASF	AMF	DF

709.4-FS-Baldassarra-CTC

FS38 – 12

709.4

Proponent: Douglas H. Evans, P.E., Clark County Building, representing Southern Nevada Chapter ICC (DHE@ClarkCountyNV.gov)

Revise as follows:

709.4 Continuity. *Smoke barriers* shall form an effective membrane continuous ~~from outside wall to outside wall~~ and from the top of the foundation or floor/ceiling assembly below to the underside of the floor or roof sheathing, deck or slab above, including continuity through concealed spaces, such as those found above suspended ceilings, and interstitial structural and mechanical spaces. The supporting construction shall be protected to afford the required *fire-resistance rating* of the wall or floor supported in buildings of other than Type IIB, IIIB or VB construction.

Exceptions:

1. Smoke-barrier walls are not required in interstitial spaces where such spaces are designed and constructed with ceilings that provide resistance to the passage of fire and smoke equivalent to that provided by the smoke-barrier walls.
2. ~~Smoke barriers used for elevator lobbies in accordance with Section 405.4.3, 3007.4.2 or 3008.11.2 are not required to extend from outside wall to outside wall.~~
3. ~~Smoke barriers used for areas of refuge in accordance with Section 1007.6.2 are not required to extend from outside wall to outside wall.~~

Reason: Requiring smoke barrier walls to be continuous from outside wall to outside wall can prove to be impractical in many applications. Many smoke control system employ passive smoke barriers as well as pressurization method zones that are wholly within a building where the smoke boundary walls do not intersect with the outside walls. The code requires smoke control systems for atria, underground buildings, Group I occupancies and covered malls. Requiring the smoke barrier wall to extend from outside wall to outside wall restricts the designer to certain parameters and limits the design of the building. In the instance of an atrium, if located within the center core of a building, requiring a fire-resistance rated separation to extend from outside wall to outside wall adds additional rated separations that are simply not needed when a smoke barrier wall around the atrium would meet the intent of the code by adequately separating the atrium from the balance of the facility. Underground buildings require compartmentation and therefore smoke barrier construction may be considered as redundant and unnecessary. Covered malls may be designed, and often are designed, as one large smoke zone, thereby eliminating the need for smoke barrier construction. The use of an outside wall is not required to make the system functional and provides no additional benefit.

Cost impact: None

Analysis: FS37, FS38 and FS39 provide different requirements for smoke barriers enclosing elevator lobbies. The committee needs to make its intent clear with respect to these provisions.

FS38-12

Public Hearing:	Committee:	AS	AM	D
	Assembly:	ASF	AMF	DF

709.4-FS-EVANS

FS39 – 12

709.4

Proponent: Dave Frable, representing U.S. General Services Administration, Public Buildings Service

Revise as follows:

709.4 Continuity. Smoke barriers shall form an effective membrane continuous ~~from outside wall to outside wall and~~ from the top of the foundation or floor/ceiling assembly below to the underside of the floor or roof sheathing, deck or slab above, including continuity through concealed spaces, such as those found above suspended ceilings, and interstitial structural and mechanical spaces. The supporting construction for a smoke barrier shall be protected to afford the required fire-resistance rating of the wall or floor supported in buildings of other than Type IIB, IIIB or VB construction. Smoke barrier walls used to separate smoke compartments shall comply with Section 709.4.2. Smoke barrier walls used to enclose areas of refuge in accordance with Section 1007.6.2 or to enclose elevator lobbies in accordance with Section 405.4.3, 3007.7.2, or 3008.7.2 shall comply with Section 709.4.3.

Exceptions:

1. Smoke-barrier walls are not required in interstitial spaces where such spaces are designed and constructed with ceilings that provide resistance to the passage of fire and smoke equivalent to that provided by the smoke-barrier walls.
2. ~~Smoke barriers used for elevator lobbies in accordance with Section 405.4.3, 3007.4.2 or 3008.11.2 are not required to extend from outside wall to outside wall.~~
3. ~~Smoke barriers used for areas of refuge in accordance with Section 1007.6.2 are not required to extend from outside wall to outside wall.~~

709.4.2 Smoke barrier walls separating smoke compartments. Smoke barrier walls used to separate smoke compartments shall form an effective membrane continuous from outside wall to outside wall.

709.4.3 Smoke barrier walls enclosing areas of refuge or elevator lobbies. Smoke barrier walls used to enclose areas of areas of refuge in accordance with Section 1007.6.2, or elevator lobbies in accordance with Section 405.4.3, 3007.7.2, or 3008.7.2, shall form an effective membrane enclosure that terminates at a smoke barrier wall or fire barrier wall having a level of fire protection rating not less than 1-hour.

Reason: The intent of this code change proposal is to provide clarification to ensure that the area of refuge and the specific enclosed elevator lobbies are designed to minimize any potential intrusion of smoke. In addition, the proposed new text ensures that the termination wall of the smoke barrier will have a fire resistance rating equivalent to the fire resistance rating of the required smoke barrier. Also, the reference to sections 3007.4.2 and 3008.11.2 was also editorially corrected.

Cost Impact: This code change will not increase the cost of construction.

Analysis: FS37, FS38 and FS39 provide different requirements for smoke barriers enclosing elevator lobbies. The committee needs to make its intent clear with respect to these provisions.

FS39-12

Public Hearing:	Committee:	AS	AM	D
	Assembly:	ASF	AMF	DF

709.4-E-FRABLE

FS40 – 12

709.5, 709.5.1 (New)

Proponent: William E. Koffel, P.E., Koffel Associates, Inc. (wkoffel@koffel.com)

Revise as follows:

709.5 Openings. Openings in a smoke barrier shall be protected in accordance with Section 716.

Exceptions:

1. In Group I-2 and ambulatory care facilities, where ~~doors are installed across corridors~~, a pair of opposite-swinging doors are installed across a corridor in accordance with Section 709.5.1, the doors shall not be required to be protected in accordance with Section 716. ~~without a center mullion shall be installed having have vision panels with fire-protection-rated glazing materials in fire-protection-rated frames, the area of which shall not exceed that tested.~~ The doors shall be close fitting within operational tolerances, and shall not have a center mullion or undercuts in excess of ³/₄-inch, louvers or grilles. The doors shall have head and jamb stops, and astragals or rabbets at meeting edges. ~~and shall be automatic-closing by smoke detection in accordance with Section 716.5.9.3.~~ Where permitted by the door manufacturer's listing, positive-latching devices are not required.
2. In Group I-2 and ambulatory care facilities, horizontal sliding doors installed in accordance with Section 1008.1.4.3 and protected in accordance with Section 716.

709.5.1 Group I-2 and ambulatory care facilities. In Group I-2 and ambulatory care facilities, where doors are installed across a corridor, the doors shall be automatic closing by smoke detection in accordance with Section 716.5.9.3 and shall have a vision panel with fire-protection rated glazing materials in fire-protection-rated frames, the area of which shall not exceed that tested.

Reason: The first exception has been revised to clarify that it only applies when swinging doors are installed and does not require the use of swinging doors. Adding the second exception in the 2009 Edition helped with this issue but the proposed language is submitted for additional clarity.

The requirements for automatic closing doors and a vision panel have been removed from the first exception and added as a specific requirement. The Code should require the vision panel in both swinging and horizontal sliding doors. The purpose of the vision panel is to allow one to see if someone is in closing proximity to the door (applies only to swinging doors) and to allow the staff to check conditions on the other side of the door prior to opening the door. Both swinging doors and horizontal sliding doors, when installed across a corridor, are to be automatic-closing. Both of these requirements currently apply to such facilities due to licensure, certification, and accreditation requirements.

Cost Impact: None

FS40-12

Public Hearing:	Committee:	AS	AM	D
	Assembly:	ASF	AMF	DF

709.5-FS-KOFFEL

FS41 – 12

404.6, 710.1, 710.5.2, 710.5.2.1, 710.5.2.2, 710.5.2.3, 713.14.1

Proponent: Joe Pierce, Dallas Fire Department, TX, representing the ICC Fire Code Action Committee

Revise as follows:

404.6 Enclosure of atriums. Atrium spaces shall be separated from adjacent spaces by a 1-hour fire barrier constructed in accordance with Section 707 or a horizontal assembly constructed in accordance with Section 711, or both.

Exception: A fire barrier is not required where a glass wall forming a smoke partition is provided. The glass wall shall comply with all of the following:

1. Automatic sprinklers are provided along both sides of the separation wall and doors, or on the room side only if there is not a walkway on the atrium side. The sprinklers shall be located between 4 inches and 12 inches (102 mm and 305 mm) away from the glass and at intervals along the glass not greater than 6 feet (1829 mm). The sprinkler system shall be designed so that the entire surface of the glass is wet upon activation of the sprinkler system without obstruction;
 - 1.1. The glass wall shall be installed in a gasketed frame in a manner that the framing system deflects without breaking (loading) the glass before the sprinkler system operates; and
 - 1.2. Where glass doors are provided in the glass wall, they shall be either self-closing or automatic-closing upon detection of smoke in accordance with Section 716.5.9.3.
2. A fire barrier is not required where a glass-block wall assembly complying with Section 2110 and having a 3/4-hour fire protection rating is provided.
3. A fire barrier is not required between the atrium and the adjoining spaces of any three floors of the atrium provided such spaces are accounted for in the design of the smoke control system.

Revise as follows:

SECTION 710 SMOKE PARTITIONS

710.1 General. ~~Smoke partitions installed as required elsewhere in the code shall comply with this section.~~ The following wall assemblies shall comply with this section:

1. Walls separating atrium spaces as required by Section 404.6 Exception #1.
2. Group I-2 corridor walls as required by Section 407.3.
3. Group I-2 care suite separations as required by Section 407.4.3.2.
4. Elevator lobby walls as required by Section 713.14.1 Exception #5.

710.5.2 Doors. ~~Doors in smoke partitions shall comply with Sections 710.5.2.1 through 710.5.2.3.~~

710.5.2.4 Louvers in Doors. Doors in smoke partitions shall not include louvers.

710.5.2.2 Smoke and draft control doors. ~~Where required elsewhere in the code, doors in smoke partitions shall meet the requirements for a smoke and draft control door assembly tested in accordance with UL 1784. The air leakage rate of the door assembly shall not exceed 3.0 cubic feet per minute per square foot (0.015424 m³/(s • m²)) of door opening at 0.10 inch (24.9 Pa) of water for both the ambient temperature test and the elevated temperature exposure test. Installation of smoke doors shall be in accordance with NFPA 105.~~

~~710.5.2.3 Self- or automatic-closing doors. Where required elsewhere in the code, doors in smoke partitions shall be self- or automatic-closing by smoke detection in accordance with Section 716.5.9.3.~~

713.14.1 Elevator lobby. An enclosed elevator lobby shall be provided at each floor where an elevator shaft enclosure connects more than three stories. The lobby enclosure shall separate the elevator shaft enclosure doors from each floor by fire partitions. In addition to the requirements in Section 708 for fire partitions, doors protecting openings in the elevator lobby enclosure walls shall also comply with Section 716.5.3 as required for corridor walls and penetrations of the elevator lobby enclosure by ducts and air transfer openings shall be protected as required for corridors in accordance with Section 717.5.4.1. Elevator lobbies shall have at least one means of egress complying with Chapter 10 and other provisions within this code.

Exceptions:

1. Enclosed elevator lobbies are not required at the level(s) of exit discharge, provided the level(s) of exit discharge is equipped with an automatic sprinkler system in accordance with Section 903.3.1.1.
2. Elevators not required to be located in a shaft in accordance with Section 712.1 are not required to have enclosed elevator lobbies.
3. Enclosed elevator lobbies are not required where additional doors are provided at the hoistway opening in accordance with Section 3002.6. Such doors shall comply with the smoke and draft control door assembly requirements in Section 716.5.3.1 when tested in accordance with UL 1784 without an artificial bottom seal.
4. Enclosed elevator lobbies are not required where the building is protected by an automatic sprinkler system installed in accordance with Section 903.3.1.1 or 903.3.1.2. This exception shall not apply to the following:
 - 4.1. Group I-2 occupancies;
 - 4.2. Group I-3 occupancies; and
 - 4.3. Elevators serving floor levels over 75 feet (22 860 mm) above the lowest level of fire department vehicle access in high-rise buildings.
5. Smoke partitions shall be permitted in lieu of *fire partitions* to separate the elevator lobby at each floor where the building is equipped throughout with an *automatic sprinkler system* installed in accordance with Section 903.3.1.1 or 903.3.1.2. ~~In addition to the requirements in Section 710 for smoke partitions, doors~~ Doors protecting openings in the smoke partitions shall be self- or automatic-closing upon detection of smoke in accordance with Section 716.5.9.3 and also comply with Sections ~~710.5.2.2 716.5.3.1, 710.5.2.3, and 716.5.9~~ and duct Duct penetrations of the smoke partitions shall be protected as required for *corridors* in accordance with Section 717.5.4.1.
6. Enclosed elevator lobbies are not required where the elevator hoistway is pressurized in accordance with Section 909.21.
7. Enclosed elevator lobbies are not required where the elevator serves only open parking garages in accordance with Section 406.5.

Reason: The intent of this proposal is to format the requirements for smoke partitions to clarify the application of the various features of smoke partitions.

Smoke partitions are required in only 4 sections of the code. Those sections are 404.6, 407.3, 407.4.3.2 and 713.14.1.

Section 710.1 is revised to list the 4 sections rather than state "elsewhere in the code" and then expect the code user to go find the sections.

Section 710.5.2.2 is deleted. Elevator lobbies are the only locations where smoke control doors are required. Since this is the only section where smoke control doors are required, rather than state "elsewhere in the code" it is clearer to revise Section 713.14.1 to contain the requirements and make reference directly to Section 716.5.9.3.

Section 710.5.2.3 is also deleted. Since doors in smoke partitions in elevator lobbies are handled in the revision to Section 713.4.1, there are only two sections which meet the "elsewhere in the code" criteria. The Sections are 404.6 and 407.3.1. Section 407.3.1 already makes the requirement for corridor walls in Group I-2. A minor revision to Section 404.6 and a reference directly to Section 716.5.9.3 covers the issue.

Within all of these revisions, the code requirements remain the same; the proposal does not change the current technical requirements in the code. Most importantly, Section 710 is simplified, and the occupancy or use specific requirements are located with other requirements for those occupancies and uses.

Section 710.3 was not revised since a smoke partition may be required to have a fire-resistance rating such as with a fire barrier or a horizontal assembly. In these cases, the design profession will need to comply with the other provisions in IBC Chapter 7 as well as the requirements for smoke partitions.

NOTE: The table below lists every subsection of 710 in the left column and the four locations where smoke partitions are required in the header. Each specific requirement is identified as either applying to those specific sections, or revisions are suggested to correlate the code requirements. The revisions shown in the table are the same revisions contained in this proposal, but you can see how each section was reviewed and evaluated.

Smoke Partition requirements in Section 710 with proposed revisions	Where smoke partitions are required under the IBC				Comments
	404.6 Exception: For Atrium enclosure	407.3: I-2 corridor wall construction	407.4.3.2: I-2 care suite separation	713.14.1 Exception #5: Elevator lobby	
<p>710.1 General. Smoke partitions installed as required elsewhere in the code shall comply with this section. <u>The following wall assemblies shall comply with this section:</u></p> <p>1. Walls separating atrium spaces as required by Section 404.6 Exception #1</p> <p>2. Group I-2 corridor walls as required by Section 407.3.</p> <p>3. Group I-2 care suite separations as required by Section 407.4.3.2.</p> <p>4. Elevator lobby walls as required by Section 713.14.1 Exception #5.</p>	✓	✓	✓	✓	<p>Revision Section 710.1 to identify where smoke partitions are used.</p> <p>This revision makes Section 710.1 user-friendly and clarifies where the 4 locations in the Code smoke partitions are required. Similar to existing Section 708.1 format that is for fire partitions.</p>
<p>710.2 Materials. The walls shall be of materials permitted by the building type of construction.</p>	✓	✓	✓	✓	
<p>710.3 Fire-resistance rating. Unless required elsewhere in the code, s partitions are not required to have a <i>fire-resistance rating</i>.</p>	Non-fire rated	Non-fire rated	Non-fire rated	Non-fire rated	<p>Smoke partitions are designed to resist the passage of smoke. If a wall that is a smoke partition is also required to be a fire partition or fire barrier, then it would need to comply with both requirements.</p>
<p>710.4 Continuity. Smoke partitions shall extend from the top of the foundation or floor below to the underside of the floor or roof sheathing, deck or slab above or to the underside of the ceiling above where the ceiling membrane is constructed to limit the transfer of smoke.</p>	✓	✓	✓	✓	

Smoke Partition requirements in Section 710 with proposed revisions	Where smoke partitions are required under the IBC				Comments
	404.6 Exception: For Atrium enclosure	407.3: I-2 corridor wall construction	407.4.3.2: I-2 care suite separation	713.14.1 Exception #5: Elevator lobby	
710.5 Openings. Openings in smoke partitions shall comply with Sections 710.5.1 and 710.5.2.	Only a pointer section to requirements in following subsections	Only a pointer section to requirements in following subsections	Only a pointer section to requirements in following subsections	Only a pointer section to requirements in following subsections	
710.5.1 Windows. Windows in smoke partitions shall be sealed to resist the free passage of smoke or be automatic-closing upon detection of smoke.	✓	✓	✓	✓	
710.5.2 Doors. Doors in smoke partitions shall comply with Sections 710.5.2.1 through 710.5.2.3.	Only a pointer section to requirements in following subsections	Only a pointer section to requirements in following subsections	Only a pointer section to requirements in following subsections	Only a pointer section to requirements in following subsections	No longer needed since the requirements under Sections 710.5.2.2 & 710.5.2.3 are placed directly into the sections of Code that use these requirements. See Comments below.
710.5.2.4 Louvers in Doors. Doors in smoke partitions shall not include louvers.	✓	✓	✓	✓	Revised code section since Section 710.5.2 was not needed as a pointer if Sections 710.5.2.2 & 710.5.2.3 will be placed directly in the two places where the code requirements is actually required. See Comments below.

Smoke Partition requirements in Section 710 with proposed revisions	Where smoke partitions are required under the IBC				Comments
	404.6 Exception: For Atrium enclosure	407.3: I-2 corridor wall construction	407.4.3.2: I-2 care suite separation	713.14.1 Exception #5: Elevator lobby	
<p>710.5.2.2 Smoke and draft control doors. Where required elsewhere in the code, doors in smoke partitions shall meet the requirements for a smoke and draft control door assembly tested in accordance with UL 1784. The air leakage rate of the door assembly shall not exceed 3.0 cubic feet per minute per square foot (0.015424 m³/(s • m²)) of door opening at 0.10 inch (24.9 Pa) of water for both the ambient temperature test and the elevated temperature exposure test. Installation of smoke doors shall be in accordance with NFPA 105.</p>	Not Required	Not Required	Not Required	<p style="text-align: center;">✓</p> <p>713.14.1 Elevator lobby. Exceptions: 5. Smoke partitions shall be permitted in lieu of <i>fire partitions</i> to separate the elevator lobby at each floor where the building is equipped throughout with an <i>automatic sprinkler system</i> installed in accordance with Section 903.3.1.1 or 903.3.1.2. In addition to the requirements in Section 710 for smoke partitions, dDoors protecting openings in these walls smoke partitions shall <u>be self- or automatic-closing upon detection of smoke in accordance with Section 716.5.9.3</u> and also comply with Sections 710.5.2.2, 716.5.3.1, 710.5.2.3, and 716.5.9 and dDuct penetrations of the smoke partitions shall be protected as required for <i>corridors</i> in accordance with Section 717.5.4.1.</p>	<p>Since on the elevator lobby exception requires smoke control doors, directly reference this requirement in Section 713.14.1 Exception #5 to Section 716.5.3.1 that is the same wording and requirement for “opening protectives” In addition, instead of referencing Sections 710.5.2.3 and 716.5.9, go directly to the requirement for self or automatic closing doors in Section 716.5.9.3.</p>

Smoke Partition requirements in Section 710 with proposed revisions	Where smoke partitions are required under the IBC				Comments
	404.6 Exception: For Atrium enclosure	407.3: I-2 corridor wall construction	407.4.3.2: I-2 care suite separation	713.14.1 Exception #5: Elevator lobby	
<p>710.5.2.3 Self- or automatic-closing doors. Where required elsewhere in the code, doors in smoke partitions shall be self- or automatic-closing by smoke detection in accordance with Section 716.5.9.3.</p>	<p>✓ 404.6 Exceptions: A fire barrier is not required where a glass wall forming a smoke partition is provided. The glass wall shall comply with all of the following: 1.2. Where glass doors are provided in the glass wall, they shall be either <i>self-closing</i> or <i>automatic closing upon detection of smoke in accordance with Section 716.5.9.3.</i></p>	<p>Not needed. Already covered by Section 407.3.1: 407.3.1 Corridor doors. Corridor doors, other than those in a wall required to be rated by Section 509.4 or for the enclosure of a vertical opening or an exit, shall not have a required fire protection rating and shall not be required to be equipped with self-closing or automatic-closing devices, but shall provide an effective barrier to limit the transfer of smoke and shall be equipped with positive latching. Roller latches are not permitted. Other doors shall conform to Section 716.5.</p>	<p>Not Required</p>	<p>✓ See recommended revision to Exception #5 above and the comment.</p>	<p>For the two places in the Code that require the self or automatic closing doors for its smoke partitions it is more user friendly and more direct just to incorporate the reference to Section 716.5.9.3 for the atrium and elevator exceptions then to go through Section 710.5.2.3 to get to Section 716.5.9.3.</p>
<p>710.6 Penetrations. The space around penetrating items shall be filled with an <i>approved</i> material to limit the free passage of smoke.</p>	<p>✓</p>	<p>✓</p>	<p>✓</p>	<p>✓</p>	
<p>710.7 Joints. Joints shall be filled with an <i>approved</i> material to limit the free passage of smoke.</p>	<p>✓</p>	<p>✓</p>	<p>✓</p>	<p>✓</p>	

Smoke Partition requirements in Section 710 with proposed revisions	Where smoke partitions are required under the IBC				Comments
	404.6 Exception: For Atrium enclosure	407.3: I-2 corridor wall construction	407.4.3.2: I-2 care suite separation	713.14.1 Exception #5: Elevator lobby	
<p>710.8 Ducts and air transfer openings. The space around a duct penetrating a smoke partition shall be filled with an <i>approved</i> material to limit the free passage of smoke. Air transfer openings in smoke partitions shall be provided with a <i>smoke damper</i> complying with Section 717.3.2.2. Exception: Where the installation of a <i>smoke damper</i> will interfere with the operation of a required smoke control system in accordance with Section 909, <i>approved</i> alternative protection shall be utilized.</p>	✓	✓	✓	✓	

Cost Impact: The code change will not increase the cost of construction.

FS41-12

Public Hearing: Committee: AS AM D
Assembly: ASF AMF DF

710-FS-PIERCE-FCAC

FS42 – 12

710.4

Proponent: John Williams, CBO, Chair, ICC Ad Hoc Committee on Healthcare

Revise as follows:

710.4 Continuity. Smoke partitions shall extend from the top of the foundation or floor below to the underside of the floor or roof sheathing, deck or slab above or to the underside of the ceiling above where the ceiling membrane is constructed to limit the transfer of smoke. A lay-in ceiling system that is designed to limit the transfer of smoke shall be permitted. Hold-down clips for such ceilings shall not be required where the ceiling tiles will resist an uplifting force of at least one pound per square foot of tile.

Reason: This proposal is submitted by the ICC Ad Hoc Committee for Healthcare (AHC). The AHC was established by the ICC Board of Directors to evaluate and assess contemporary code issues relating to hospitals and ambulatory healthcare facilities. The AHC is composed of building code officials, fire code officials, hospital facility engineers, and state healthcare enforcement representatives. The goals of the committee are to ensure that the ICC family of codes appropriately addresses the fire and life safety concerns of a highly specialized and rapidly evolving healthcare delivery system. This process is part of a joint effort between ICC and the American Society for Healthcare Engineering (ASHE), a subsidiary of the American Hospital Association, to eliminate duplication and conflicts in healthcare regulation. Since its inception in April, 2011, the AHC has held 5 open meetings and over 80 workgroup calls which included members of the AHC as well as any interested party to discuss and debate the proposed changes. All meeting materials and reports are posted on the AHC website at: <http://www.iccsafe.org/cs/AHC/Pages/default.aspx>

Current interpretation of an allowable ceiling system is to be "monolithic." This type of ceiling is not feasible in a hospital setting, because main utility and ductwork lines run in the corridor to keep them out of patient care areas. This would facilitate the need for many access panels which compromise the smoke tight nature of the monolithic ceiling. The construction of the lay-in system would basically mean no open portions or gaps in the ceiling, either as an architectural feature or between items such as louvers. Normal ceiling fixtures such as lights, sprinkler heads, and diffusers and grills (as part of a fully ducted air system) can be considered part of the smoke tight system, as there is no opportunity for smoke to travel straight through them. A tight fitting lay-in grid is defined as one with no gaps in them, which is easily enforced via visual inspection and is therefore simply maintained.

The one pound per square foot weight can handle an updraft concerns because a facility equipped with QRS sprinklers will not generate enough heat to cause the updraft to move the tile. Hold-down clips in this instance would not be necessary, as the weight of the tile itself would be sufficient. Due to the need for access to above ceiling utilities, hold-down clips would interfere with maintenance and operations, which is why an updraft limitation is considered.

Since a fully ducted air handling system is required in the I-2 hospital occupancy, plenum ceilings that compromise the ceiling system are already prohibited.

Cost Impact: The code change proposal will not increase the cost of construction.

FS42-12

Public Hearing:	Committee:	AS	AM	D
	Assembly:	ASF	AMF	DF

710.4-FS-Williams-AdHocHealthcare

FS43 – 12

710.5.2.2.1 (New)

Proponent: Jeff Inks, Window and Door Manufacturers Association, representing the National Architectural Door Council (jinks@wdma.com)

Revise as follows:

710.5.2.2.1 Smoke and draft control door labeling. Smoke and draft control doors complying only with UL 1784 shall be permitted to show the letter “S” on the manufacturer’s labeling.

Reason: Based upon feedback from manufacturers of smoke control and fire doors, there is inconsistent understanding in the field of what the use of the “S” letter marking on a door means and whether it is permitted to be used on doors that are not fire rated as required by Section 716.

Historically, the legacy codes, using the UBC as an example, only permitted the “S” letter marking to be used on doors that passed the air leakage portion (Part 2) of UBC 7-2 (1997). However, doors first had to pass Part 1 (Fire Endurance). Consequently only fire doors were allowed to bear the “S” letter mark.

The IBC contains no such requirement and is therefore silent on whether non-fire-rated doors, such as those allowed in smoke partitions, are permitted to bear the “S” letter mark. While the IBC requires rated fire doors that meet the requirements of UL 1784 to indicate that by including the “S” mark on the fire label, there is neither restriction nor requirement regarding the use of the “S” letter mark on non-fire-rated doors. It is also not unusual for design professionals to specify that the “S” letter mark be included by the manufacture on their labeling of non-rated smoke partition doors, but some manufacturers have been hesitant to do so because of the legacy code provisions.

This proposal helps clarify that the use of the “S” letter mark is intended only to indicate conformance to UL 1784, and allows use of the marking on smoke partition doors that conform to that test standard.

Cost Impact: This will not increase the cost of construction.

FS43-12

Public Hearing:	Committee:	AS	AM	D
	Assembly:	ASF	AMF	DF

710.5.2.2.1 (NEW)-FS-INKS

FS44 – 12

711.4.1, 712.1.17

Proponent: Gregory R. Keith, Professional heuristic Development, representing The Boeing Company (grkeith@mac.com)

Delete without substitution:

~~**711.4.1 Nonfire-resistance-rated assemblies.** Joints in or between floor assemblies without a required fire-resistance rating shall comply with one of the following:~~

- ~~1. The joint shall be concealed within the cavity of a wall.~~
- ~~2. The joint shall be located above the ceiling.~~
- ~~3. The joint shall be sealed, treated or covered with an approved material or system to resist the free passage of flame and the products of combustion.~~

~~**712.1.17 Nonfire-resistance-rated joints.** Joints in or between floors without a required fire-resistance rating shall be permitted in accordance with section 711.4.1.~~

(Renumber subsequent sections)

Reason: Section 711.4.1 is new to the 2012 Edition of the IBC. The provision was included as a portion of Item FS56-09/10 that was a relatively comprehensive reorganization of Chapter 7 vertical opening provisions. In its published reason statement, the proponent of FS56-09/10 stated, "Most of the changes proposed by the study group are editorial in nature and will not change how the code is applied or used." Our main proposal includes only amendments that this group feels are editorial or very minor changes."

The fact of the matter is that the proposal included substantial technical revisions without benefit of any justification or discussion. Section 711.4.1 is one such provision. Section 711 applies to "horizontal assemblies." The definition of horizontal assembly in Section 202 states, "A fire-resistance rated floor or roof assembly of materials designed to restrict the spread of fire in which continuity is maintained." Section 711.1 states, "Floor and roof assemblies required to have a fire-resistance rating shall comply with this section." Additionally, it states, "Nonfire-resistance-rated floor and roof assemblies shall comply with Section 714.4.2." Section 714.4.2 provides for the protection of penetrations in non-fire-resistance-rated floor or roof assemblies.

Section 711.4.1 introduces new joint protection requirements for nonfire-resistance-rated floor assemblies where none previously existed. There was no technical justification for these more stringent provisions for non-rated construction. Additionally, there is no charging language to cause application of Section 711.4.1. Section 711.1 states that nonfire-resistance-rated floor and roof assemblies only need comply with Section 714.4.2, with no mention of Section 711.4.1. However, a new Section 712.1.17 does provide an off-handed allowance for joints in nonfire-resistive-rated floor assemblies that comply with Section 711.4.1.

The provisions of Section 711.4.1 are very severe in that they apply regardless of the number of connected stories. Inexplicably, fire protection requirements for non-rated construction continue to appear in the IBC without benefit of technical justification or statistical fire loss substantiation. The fact of the matter is that with only three exceptions (Groups B, F-2 and S-2), in unsprinklered buildings Table 601 only permits nonfire-resistance-rated floor construction in two story buildings. The IBC generally allows for two-story atmospheric communication, even in fire-resistance-rated types of construction.

Approval of this proposal will delete 2012 IBC Sections 711.4.1 and 712.1.17 and will return details of construction in nonfire-resistance-rated floor and roof assemblies to former levels that have proven to be appropriate based on the actual risk conditions as opposed to some unfounded hypothetical concern.

Cost Impact: None

FS44-12

Public Hearing:	Committee:	AS	AM	D
	Assembly:	ASF	AMF	DF

711.4.1-FS-KEITH

FS45 – 12

711.5

Proponent: Gregory R. Keith, Professional heuristic Development, representing The Boeing Company (grkeith@mac.com)

Revise as follows:

711.5 Penetrations. Penetrations of horizontal assemblies, ~~whether concealed or unconcealed~~, shall comply with Section 714.

Reason: Section 711.5 was modified in the 2012 Edition of the IBC. The provision was included as a portion of Item FS56-09/10 that was a relatively comprehensive reorganization of Chapter 7 vertical opening provisions. In its published reason statement, the proponent of FS56-09/10 stated, "Most of the changes proposed by the study group are editorial in nature and will not change how the code is applied or used." Our main proposal includes only amendments that this group feels are editorial or very minor changes."

Although 2012 Section 711.5 has no marginal reference indicating a technical change from the 2009 Edition of the IBC, the fact of the matter is that FS56-09/10 included a substantial technical revision without any justification or discussion. That was, the qualification that Section 714 penetration protection requirements apply "whether the penetration is concealed or unconcealed."

"Concealed" and "unconcealed" are terms that are neither defined in Section 202 nor used in technical context in Section 711, Horizontal Assemblies or Section 714, Penetrations. The terms will create confusion and lend to inconsistent interpretations of fundamental horizontal assembly penetration protection provisions. Some may argue that a penetration of a horizontal assembly occurring within a shaft enclosure is concealed, and therefore requires additional protection.

Section 714.4 currently adequately addresses horizontal assembly penetration conditions. The "through penetration" and "membrane penetration" concept has been in place for many IBC editions and is understood by code practitioners. There is no demonstrated need to further clarify these provisions. The 2012 language confuses the fundamental provisions.

Since there was no technical substantiation of this language as a portion of a code change represented as being editorial, it is unknown what is actually intended by this ambiguous terminology. As stated, it will create doubt and generate protection of construction features beyond those conditions currently addressed in the IBC.

Until Section 714.4 is rewritten to specifically address what concealed and unconcealed construction actually is and what is technical requirements potentially apply to these design conditions, the charging terminology should be removed from Section 711.5. It is certainly a subject area deserving of technical vetting that did not occur during the approval of FS56-09/10. Approval of this proposal will restore Section 711.5 to its former, understandable intent.

Cost Impact: None

FS45-12

Public Hearing:	Committee:	AS	AM	D
	Assembly:	ASF	AMF	DF

711.5-FS-KEITH

FS46 – 12

711.8

Proponent: William E. Koffel, P.E., Koffel Associates, Inc. representing Bilco Company
(wkoffel@koffel.com)

Revise as follows:

711.8 ~~Floor~~ Horizontal fire door assemblies. ~~Floor~~Horizontal fire door assemblies used to protect openings in fire-resistance-rated ~~floors~~ horizontal assemblies shall be tested in accordance with NFPA 288, and shall achieve a *fire-resistance rating* not less than the assembly being penetrated. ~~Floor~~Horizontal fire door assemblies shall be labeled by an *approved agency*. The *label* shall be permanently affixed and shall specify the manufacturer, the test standard and the *fire-resistance rating*.

Reason: The Scope of NFPA 288, 2012 Edition has been expanded to include fire doors installed in fire-resistance rated horizontal assemblies, including fire resistance rated roof assemblies. The proposed change is consistent with the change in scope of NFPA 288

Cost Impact: None

FS46-12

Public Hearing:	Committee:	AS	AM	D
	Assembly:	ASF	AMF	DF

712.8-FS-KOFFEL

FS47– 12

711.9

Proponent: John Williams, CBO, Chair, ICC Ad Hoc Committee on Healthcare

Revise as follows:

711.9 Smoke barrier. Where *horizontal assemblies* are required to resist the movement of smoke by other sections of this code in accordance with the definition of *smoke barrier*, penetrations and joints in such *horizontal assemblies* shall be protected as required for *smoke barriers* in accordance with Sections 714.5 and 715.6. ~~Regardless of the number of stories connected by elevator shaft enclosures, doors located in elevator shaft enclosures that penetrate the *horizontal assembly* shall be protected in accordance by enclosed elevator lobbies complying with Section 713.14.1.~~ Openings through *horizontal assemblies* shall be protected by shaft enclosures complying with Section 713. *Horizontal assemblies* shall not be allowed to have unprotected vertical openings.

Reason: The reason for this change is to clarify the code. This code changes addresses text new in the 2009 IBC. The new text creates in effect a hidden requirement for elevator lobbies. We are proposing to clearly direct user of the code to Section 713.14.1 for the scoping language for elevator lobbies, as well as construction methods and any exceptions.

This proposal is submitted by the ICC Ad Hoc Committee on Healthcare (AHC). The AHC was established by the ICC Board of Directors to evaluate and assess contemporary code issues relating to hospitals and ambulatory healthcare facilities. The AHC is composed of building code officials, fire code officials, hospital facility engineers, and state healthcare enforcement representatives. The goals of the committee are to ensure that the ICC family of codes appropriately addresses the fire and life safety concerns of a highly specialized and rapidly evolving healthcare delivery system. This process is part of a joint effort between ICC and the American Society for Healthcare Engineering (ASHE), a subsidiary of the American Hospital Association, to eliminate duplication and conflicts in healthcare regulation. Since its inception in April, 2011, the AHC has held 5 open meetings and over 80 workgroup calls which included members of the AHC as well as any interested party to discuss and debate the proposed changes. All meeting materials and reports are posted on the AHC website at: <http://www.iccsafe.org/cs/AHC/Pages/default.aspx>.

Cost Impact: None

Analysis: FS47 revises provisions for in elevator shaft enclosures. FS48 and FS49 delete these provisions. The committee needs to make its intent clear with respect to these provisions.

FS47-12

Public Hearing:	Committee:	AS	AM	D
	Assembly:	ASF	AMF	DF

711.9-FS-Williams-Adhoc

FS48 – 12

711.9

Proponent: Al Godwin, CBO, CPM, representing Aon Fire Protection Engineering (al.godwin@aon.com)

Revise as follows:

711.9 Smoke barrier. Where *horizontal assemblies* are required to resist the movement of smoke by other sections of this code in accordance with the definition of *smoke barrier*, penetrations and joints in such *horizontal assemblies* shall be protected as required for *smoke barriers* in accordance with Sections 714.5 and 715.6. ~~Regardless of the number of stories connected by elevator shaft enclosures, doors located in elevator shaft enclosures that penetrate the horizontal assembly shall be protected by enclosed elevator lobbies complying with Section 713.14.1.~~ Openings through *horizontal assemblies* shall be protected by shaft enclosures complying with Section 713. *Horizontal assemblies* shall not be allowed to have unprotected vertical openings.

Reason: This provision was added in the 2009 IBC under code change FS81-07/08. However, it is unclear if it overrides the exceptions of Section 713.14.1 associated with elevator lobbies.

The question that has to be asked is

"Do the Exceptions of Section 713.14.1 still apply?"

If the exceptions do not apply, then this one sentence overrules everything that has been built into the elevator lobby provisions over the past few years for occupancies with smoke barriers, such as I-2's or ambulatory health care. And, no justification was presented.

Does this mean that:

1. all uses with a smoke barrier should not be allowed to exempt the ground floor from the elevator lobby provision of exception 1?
2. that the smoke partition option of exception 5 does not work?
3. that pressurization does not work?

If the exceptions do apply, then given that lobbies are only required when connecting more than 3 floors and with exception 4, the only buildings that this provision would apply to is:

1. two and three story non-sprinklered buildings with smoke barriers, and there shouldn't be any; and,
2. two and three story Group I-2 buildings.

What justification has been presented to show that these buildings are a problem?

Cost Impact: This code change proposal will not increase the cost of construction.

Analysis: FS47 revises provisions for in elevator shaft enclosures. FS48 and FS49 delete these provisions. The committee needs to make its intent clear with respect to these provisions.

FS48-12

Public Hearing:	Committee:	AS	AM	D
	Assembly:	ASF	AMF	DF

711.9-FS-GODWIN

FS49 – 12

711.9

Proponent: Sarah A. Rice, C.B.O., representing The Preview Group (srice@preview-group.com)

Revise as follows:

711.9 Smoke barrier. Where horizontal assemblies are required to resist the movement of smoke by other sections of this code in accordance with the definition of smoke barrier, penetrations and joints in such horizontal assemblies shall be protected as required for smoke barriers in accordance with Sections ~~709 714.5 and 715.6. Regardless of the number of stories connected by elevator shaft enclosures, doors located in elevator shaft enclosures that penetrate the horizontal assembly shall be protected by enclosed elevator lobbies complying with Section 713.14.1. Openings through horizontal assemblies shall be protected by shaft enclosures complying with Section 713. Horizontal assemblies shall not be allowed to have unprotected vertical openings.~~

Reason: The current language of Section 711.9 contains provisions that are misplaced and are contradictory to other provisions in the IBC. In the Reason statement for the code change which brought this language into the code (FS81-07/08) the proponent states that "This code change proposal is intended to clarify the requirements for horizontal assemblies that are used to support smoke barrier walls such as in Group I-2 occupancies where smoke barriers are required to subdivide floors by Section 407.4." But Section 407.4 is NOT the only place in the code where smoke barriers are required, they are required also in Group I-3 occupancies.

When taken literally, the last 2 sentences totally negate the provisions found in Section 709; Smoke Barriers, and specifically the provisions found in Sections 709.5 through 709.8 which were developed to address openings, penetrations, joints and duct openings in smoke barriers – both vertical and horizontal. When looking at each of the individual sections, you find that there are multiple places where openings through horizontal assemblies are permitted to be protected by something other than a shaft enclosure.

This proposal seeks to remove the confusing language in Section 711.9 and rely rather on a simple reference to Section 709; Smoke Barriers which contains the provisions for addressing any "holes" made to smoke barriers.

2012 IBC 709.5 Openings. Openings in a smoke barrier shall be protected in accordance with Section 716.

Exceptions:

1. In Group I-2 and ambulatory care facilities, where doors are installed across corridors, a pair of opposite-swinging doors without a center mullion shall be installed having vision panels with fire-protection-rated glazing materials in fire-protection-rated frames, the area of which shall not exceed that tested. The doors shall be close fitting within operational tolerances, and shall not have undercuts in excess of 3/4-inch, louvers or grilles. The doors shall have head and jamb stops, astragals or rabbets at meeting edges and shall be automatic-closing by smoke detection in accordance with Section 716.5.9.3. Where permitted by the door manufacturer's listing, positive-latching devices are not required.
2. In Group I-2 and ambulatory care facilities, horizontal sliding doors installed in accordance with Section 1008.1.4.3 and protected in accordance with Section 716.

709.6 Penetrations. Penetrations of smoke barriers shall comply with Section 714.

709.7 Joints. Joints made in or between smoke barriers shall comply with Section 715.

709.8 Ducts and air transfer openings. Penetrations in a smoke barrier by ducts and air transfer openings shall comply with Section 717.

Noticeably absent from the proponents Reason statement was justification for the sentence "Regardless of the number of stories connected by elevator shaft enclosures, doors located in elevator shaft enclosures that penetrate the horizontal assembly shall be protected by enclosed elevator lobbies complying with Section 713.14.1." Due to the prolonged adoption of the 2009 I-Codes in many jurisdictions, it has only recently come to light the impact of this provision, which is buried deep in the horizontal assembly section. This provision, if it were to be deemed viable should not be in the Section 711 at all but in Section 713.4.1 Elevator Lobbies.

The provision buried in Section 711.9 mandates that "Regardless of the number of stories connected by elevator shaft enclosures, doors located in elevator shaft enclosures that penetrate the horizontal assembly shall be protected by enclosed elevator lobbies complying with Section 713.14.1." Depending upon how you read the sentence it could be interpreted to say that this provision overrides the "more than three stories" threshold found in Section 713.4.1 for when an elevator lobby is required –

Section 713.4.1 reads: it reads "713.14.1 Elevator lobby. An enclosed elevator lobby shall be provided at each floor where an elevator shaft enclosure connects more than three stories. The lobby enclosure shall separate the elevator shaft enclosure doors from each floor by fire partitions. In addition to the requirements in Section 708 for fire partitions, doors protecting openings in the elevator lobby enclosure walls shall also comply with Section 716.5.3 as required for corridor walls and penetrations of the elevator lobby enclosure by ducts and air transfer openings shall be protected as required for corridors in accordance with Section 717.5.4.1. Elevator lobbies shall have at least one means of egress complying with Chapter 10 and other provisions within this code."

No technical justification was ever given to validate changing the threshold found in Section 713.4.1 for elevator lobbies. This change deletes the provision from Section 711.9 in its entirety. The CTC Elevator Study Group has been studying the entire elevator lobby issue. Any drastic changes to the thresholds should come from that group.

For information purposes, the following is the Reason statement to FS81-07/08 "It is clear from the definition for "smoke barrier" that a smoke barrier can be a horizontal assembly. Furthermore, in order to provide for the continuity of the smoke protection for smoke compartments created by vertical smoke barriers to provide for relative safe areas for horizontal movement of patients in a fire emergency, it follows that the floors supporting those smoke barrier walls should also be able to resist the passage or movement of smoke through the assembly to maintain the appropriate level of protection for the occupants. Generally, occupants of Group I-2 occupancies are moved into a smoke barrier that is away from the area where the fire occurred so that they can remain until further moved as necessary or until the fire has been extinguished by the responding fire department. The provisions contained in this code change proposal we believe will provide the equivalent level of smoke protection to that of the smoke barrier for the horizontal assemblies that support the smoke barriers."

Cost Impact: This proposal will not increase the cost of construction.

Analysis: FS47 revises provisions for in elevator shaft enclosures. FS48 and FS49 delete these provisions. The committee needs to make its intent clear with respect to these provisions.

FS49-12

Public Hearing:	Committee:	AS	AM	D
	Assembly:	ASF	AMF	DF

711.9-FS-RICE

FS50 – 12

711, 712, 713, 714

Proponent: Carl Baldassarra, P.E., FSFPE, Chair, ICC Code Technology Committee

Revise as follows:

SECTION 711 FLOOR AND ROOF ASSEMBLIES HORIZONTAL ASSEMBLIES

711.1 General. ~~Floor and roof assemblies required to have a fire-resistance rating~~ Horizontal assemblies shall comply with Section 711.2 ~~this section~~. Nonfire-resistance-rated floor and roof assemblies shall comply with Section 711.3 ~~744.4.2~~.

711.2 Horizontal assemblies. Horizontal assemblies shall comply with Sections 711.2.1 through 711.2.6.

711.2.1 ~~744.2~~ Materials. ~~The floor and roof~~ Assemblies shall be of materials permitted by the building type of construction.

711.2.2 ~~744.4~~ Continuity. Assemblies shall be continuous without vertical openings, ~~penetrations or joints~~ except as permitted by this section and Sections ~~712.2, 714.4, 715, 1009.3 and 1022.1~~. ~~Skylights and other penetrations through a fire-resistance-rated roof deck or slab are permitted to be unprotected, provided that the structural integrity of the fire-resistance-rated roof assembly is maintained. Unprotected skylights shall not be permitted in roof assemblies required to be fire-resistance-rated in accordance with Section 705.8.6.~~ The supporting construction shall be protected to afford the required *fire-resistance rating* of the *horizontal assembly* supported.

Exception: In buildings of Type IIB, IIIB or VB construction, the construction supporting the *horizontal assembly* is not required to be fire-resistance-rated at the following:

1. Horizontal assemblies at the separations of incidental uses as specified by Table 509, provided the required *fire-resistance rating* does not exceed 1 hour.
2. Horizontal assemblies at the separations of *dwelling units* and *sleeping units* as required by Section 420.3.
3. Horizontal assemblies at *smoke barriers* constructed in accordance with Section 709.

711.2.3 Supporting construction. The supporting construction shall be protected to afford the required fire-resistance rating of the horizontal assembly supported.

Exception: In buildings of Type IIB, IIIB or VB construction, the construction supporting the horizontal assembly is not required to be fire-resistance-rated at the following:

1. Horizontal assemblies at the separations of incidental uses as specified by Table 509 provided the required fire-resistance rating does not exceed 1 hour.
2. Horizontal assemblies at the separations of dwelling units and sleeping units as required by Section 420.3.
3. Horizontal assemblies at smoke barriers constructed in accordance with Section 709.

711.2.4 ~~744.3~~ Fire-resistance rating. The fire-resistance rating of floor and roof horizontal assemblies shall comply with Sections 711.2.4.1 through 711.2.4.6 but shall not be less than that required by the building type of construction.

711.2.4.1 Separating mixed occupancies. Where the ~~floor-horizontal~~ assembly separates mixed occupancies, the assembly shall have a fire-resistance rating of not less than that required by Section 508.4 based on the occupancies being separated.

711.2.4.2 Separating fire areas. Where the ~~floor-horizontal~~ assembly separates a single occupancy into different fire areas, the assembly shall have a fire-resistance rating of not less than that required by Section 707.3.10.

711.2.4.3 Dwelling units and sleeping units. Where the ~~horizontal assemblies separating dwelling units in the same building and horizontal assemblies separating, or sleeping units in the same building,~~ the assembly shall be a minimum of 1-hour fire-resistance-rated construction.

Exception: ~~Horizontal assemblies separating dwelling units and sleeping units shall be a minimum of 1/2 hour fire-resistance-rated construction separations in a buildings of Type IIB, IIIB and VB construction, shall have fire-resistance ratings of not less than 1/2 hour in when the buildings is~~ equipped throughout with an automatic sprinkler system in accordance with Section 903.3.1.1.

711.2.4.4 Separating smoke compartments. Where the horizontal assembly is required to be a smoke barrier, the assembly shall comply with Section 709.

711.2.4.5 Separating incidental uses. Where the horizontal assembly separates incidental uses from the remainder of the building, the assembly shall have a fire-resistance rating of not less than that required by Section 509.

711.2.4.6 Other separations. Where a horizontal assembly is required by other sections of this code, it shall have a fire-resistance rating of not less than that required by that section.

711.2.5 711.3.4 Ceiling panels. Where the weight of lay-in ceiling panels, ~~where~~ used as part of fire-resistance-rated floor/ceiling or roof/ceiling assemblies, is not adequate to resist an upward force of 1 pound per square foot (48 Pa), wire or other approved devices shall be installed above the panels to prevent vertical displacement under such upward force.

711.2.6 711.3.3 Unusable space. In 1-hour fire-resistance-rated floor/ceiling assemblies, the ceiling membrane is not required to be installed over unusable crawl spaces. In 1-hour fire-resistance-rated roof assemblies, the floor membrane is not required to be installed where unusable attic space occurs above.

711.3 Nonfire-resistance rated floor and roof assemblies. Nonfire-resistance rated floor, floor/ceiling, roof and roof/ceiling assemblies shall comply with Sections 711.3.1 and 711.3.2.

711.3.1 Materials. Assemblies shall be of materials permitted by the building type of construction.

711.3.2 Continuity. Assemblies shall be continuous without vertical openings, except as permitted by Section 712.

711.5 Penetrations. Penetrations of horizontal assemblies, ~~whether concealed or unconcealed,~~ shall comply with Section 714.

711.7 Ducts and air transfer openings. Penetrations in horizontal assemblies by ducts and air transfer openings shall comply with Section 717.

711.9 Smoke barrier. Where horizontal assemblies are required to resist the movement of smoke by other sections of this code in accordance with the definition of smoke barrier, penetrations and joints in such horizontal assemblies shall be protected as required for smoke barriers in accordance with Sections 714.5 and 715.6. Regardless of the number of stories connected by elevator shaft enclosures, doors located in elevator shaft enclosures that penetrate the horizontal assembly shall be protected by enclosed elevator lobbies complying with Section 713.14.1. Openings through horizontal assemblies shall be

~~protected by shaft enclosures complying with Section 713. Horizontal assemblies shall not be allowed to have unprotected vertical openings.~~

SECTION 712 VERTICAL OPENINGS

712.1 General. ~~The provisions of this section shall apply to the~~ Each vertical opening applications listed shall comply with one of the protection methods in Sections 712.1.1 through 712.1.168.

712.1.1 Shaft enclosures. Vertical openings contained entirely within a shaft enclosure complying with Section 713 shall be permitted.

712.1.2 Individual dwelling unit. Unconcealed vertical openings totally within an individual residential dwelling unit and connecting four stories or less shall be permitted.

712.1.3 Escalator openings. Where a building is equipped throughout with an *automatic sprinkler system* in accordance with Section 903.3.1.1, vertical openings for an escalators opening shall be permitted when protected according to Section 712.1.3.1 or 712.1.3.2.

712.1.3.1 Opening size. Protection by a draft curtain and closely spaced sprinklers in accordance with NFPA 13 shall be permitted where the area of the vertical opening between stories does not exceed twice the horizontal projected area of the escalator. In other than Groups B and M, this application is limited to openings that do not connect more than four stories.

712.1.3.2 Automatic shutters. Protection of the vertical opening by approved shutters at every penetrated floor shall be permitted in accordance with this section. The shutters shall be of noncombustible construction and have a *fire-resistance rating* of not less than 1.5 hours. The shutter shall be so constructed as to close immediately upon the actuation of a smoke detector installed in accordance with Section 907.3.1 and shall completely shut off the well opening. Escalators shall cease operation when the shutter begins to close. The shutter shall operate at a speed of not more than 30 feet per minute (152.4 mm/s) and shall be equipped with a sensitive leading edge to arrest its progress where in contact with any obstacle, and to continue its progress on release there from.

712.1.4 Penetrations. Penetrations, concealed and unconcealed, shall be permitted where protected in accordance with Section 714.

712.1.5 Joints. Joints shall be permitted where complying with Section 712.1.5.1 or 712.1.5.2, as applicable.

712.1.5.1 ~~714.6~~ Joints in or between horizontal assemblies. Joints made in or between horizontal assemblies shall comply with Section 715. The void created at the intersection of a floor/ceiling assembly and an exterior curtain wall assembly shall be permitted when protected in accordance with Section 715.4.

712.1.5.2 ~~714.4.4~~ Joints in or between nonfire-resistance-rated floor assemblies. Joints in or between floors without a required *fire-resistance rating* shall be permitted when they comply with one of the following:

1. The joint shall be concealed within the cavity of a wall.
2. The Joint shall be located above a ceiling.
3. The joint shall be sealed, treated or covered with an approved material or system to resist the free passage of flame and the products of combustion.

Exception: Joints meeting one of the ~~joint~~ exceptions listed in Section 715.1.

712.1.6 ~~712.1.5~~ Ducts and air transfer openings. Penetrations by ducts and air transfer openings shall be protected in accordance with Section 717-6. Grease ducts shall be protected in accordance with the *International Mechanical Code*.

712.1.7 ~~712.1.6~~ Atriums. In other than Group H occupancies, atriums complying with Section 404 shall be permitted.

712.1.8 ~~712.1.7~~ Masonry chimney. Approved vertical openings for masonry chimneys shall be permitted where the annular space is fireblocked at each floor level in accordance with Section 718.2.5.

712.1.9 ~~712.1.8~~ Two-story openings. In other than Groups I-2 and I-3, a floor vertical opening that is not used as one of the applications listed in this section shall be permitted if it complies with all of the items below.

1. Does not connect more than two stories.
2. Does not contain a stairway or ramp required by Chapter 10.
3. Does not penetrate a horizontal assembly that separates fire areas or smoke barriers that separate smoke compartments.
4. Is not concealed within the construction of a wall or a floor/ceiling assembly.
5. Is not open to a corridor in Group I and R occupancies.
6. Is not open to a corridor on nonsprinklered floors.
7. Is separated from floor openings and air transfer openings serving other floors by construction conforming to required shaft enclosures.

712.1.10 ~~712.1.9~~ Parking garages. Vertical openings in parking garages for automobile ramps, elevators and duct systems shall comply with Section 712.1.10.1, 712.1.10.2 or 712.1.10.3 as applicable.
NOTE: Editorial

712.1.10.1 Automobile ramps. Vertical openings for automobile ramps in open and enclosed parking garages shall be permitted where constructed in accordance with Sections 406.5 and 406.6, respectively.

712.1.10.2 ~~712.1.15~~ Elevators in parking garages. Vertical openings for elevator hoistways in open or enclosed parking garages that serve only the parking garage, and complying with Sections 406.5 and 406.6 respectively, shall be permitted.

712.1.10.3 ~~712.1.16~~ Duct systems in parking garages. Vertical openings for mechanical exhaust or supply duct systems in open or enclosed parking garages complying with Sections 406.5 and 406.6 respectively, shall be permitted to be unenclosed where such duct system is contained within and serves only the parking garage.

712.1.11 ~~712.1.10~~ Mezzanine. Vertical openings between a mezzanine complying with Section 505 and the floor below shall be permitted.

712.1.11 Joints. Joints shall be permitted where complying with Section 715.

712.1.12 Unenclosed stairs and ramps. Vertical floor openings created by unenclosed stairs or ramps in accordance with Sections 1009.2 and 1009.3 shall be permitted.

712.1.13 Openings. Floor fire doors. Vertical openings for floor fire doors and access doors shall be permitted where protected by Section 712.1.13.1 or Section 712.1.13.2 as applicable. floor fire doors in accordance with Section 711.8.

712.1.13.1 ~~711.8~~ Floor fire door assemblies. Floor fire door assemblies used to protect openings in fire-resistance-rated floors shall be tested in accordance with NFPA 288, and shall achieve a fire-resistance rating not less than the assembly being penetrated. Floor fire door assemblies shall be labeled by an

approved agency. The label shall be permanently affixed and shall specify the manufacturer, the test standard and the fire-resistance rating.

712.1.13.2 744.3.2 Access doors. Access doors shall be permitted in ceilings of fire-resistance-rated floor/ceiling and roof/ceiling assemblies provided such doors are tested in accordance with ASTM E 119 or UL 263 as horizontal assemblies and labeled by an approved agency for such purpose.

712.1.14. Group I-3. In Group I-3 occupancies, vertical openings shall be permitted in accordance with Section 408.5.

~~**712.1.17 Nonfire-resistance-rated joints.** Joints in or between floors without a required fire-resistance rating shall be permitted in accordance with Section 711.4.1.~~

712.1.15 Skylights. Skylights and other penetrations through a fire-resistance-rated roof deck or slab are permitted to be unprotected, provided that the structural integrity of the fire-resistance-rated roof assembly is maintained. Unprotected skylights shall not be permitted in roof assemblies required to be fire-resistance rated in accordance with Section 705.8.5. The supporting construction shall be protected to afford the required fire-resistance rating of the horizontal assembly supported.

712.1.16 742.4.18 Openings otherwise permitted. Vertical openings shall be permitted where allowed by other sections of this code.

713.14.1 Elevator lobby. An enclosed elevator lobby shall be provided at each floor where an elevator shaft enclosure ~~has an opening connects more than three stories~~. The lobby enclosure shall separate the elevator shaft enclosure doors from each floor by fire partitions. In addition to the requirements in Section 708 for fire partitions, doors protecting openings in the elevator lobby enclosure walls shall also comply with Section 716.5.3 as required for corridor walls and penetrations of the elevator lobby enclosure by ducts and air transfer openings shall be protected as required for corridors in accordance with Section 717.5.4.1. Elevator lobbies shall have at least one means of egress complying with Chapter 10 and other provisions within this code.

Exceptions:

1. In other than Group I-2 or I-3 occupancies, an enclosed elevator lobby shall not be required where an elevator shaft enclosure connects not more than three stories.
- ~~21.~~ Enclosed elevator lobbies are not required at the level(s) of *exit discharge*, provided the level(s) of *exit discharge* is equipped with an *automatic sprinkler system* in accordance with Section 903.3.1.1.
- ~~32.~~ Elevators not required to be located in a shaft in accordance with Section 712.1 are not required to have enclosed elevator lobbies.
- ~~43.~~ Enclosed elevator lobbies are not required where additional doors are provided at the hoistway opening in accordance with Section 3002.6. Such doors shall comply with the smoke and draft control door assembly requirements in Section 716.5.3.1 when tested in accordance with UL 1784 without an artificial bottom seal.
- ~~54.~~ Enclosed elevator lobbies are not required where the building is protected by an *automatic sprinkler system* installed in accordance with Section 903.3.1.1 or 903.3.1.2. This exception shall not apply to the following:
 - ~~5.14.4.~~ Group I-2 occupancies;
 - ~~5.24.2.~~ Group I-3 occupancies; and
 - ~~5.34.3.~~ Elevators serving floor levels over 75 feet (22 860 mm) above the lowest level of fire department vehicle access in high-rise buildings.
- ~~65.~~ Smoke partitions shall be permitted in lieu of *fire partitions* to separate the elevator lobby at each floor where the building is equipped throughout with an *automatic sprinkler system* installed in accordance with Section 903.3.1.1 or 903.3.1.2. In addition to the requirements in Section 710 for smoke partitions, doors protecting openings in the smoke partitions shall also

comply with Sections 710.5.2.2, 710.5.2.3, and 716.5.9 and duct penetrations of the smoke partitions shall be protected as required for *corridors* in accordance with Section 717.5.4.1.

76. Enclosed elevator lobbies are not required where the elevator hoistway is pressurized in accordance with Section 909.21.

87. Enclosed elevator lobbies are not required where the elevator serves only *open parking garages* in accordance with Section 406.5.

714.4 Horizontal assemblies. Penetrations of a fire-resistance rated floor, floor/ceiling assembly or the ceiling membrane of a roof/ceiling assembly not required to be enclosed in a shaft by Section 712.1 shall be protected in accordance with Sections 714.4.1 through 714.4.4 ~~714.4.2.2~~.

~~**714.4.1 Fire-resistance-rated assemblies.** Penetrations of the fire-resistance-rated floor, floor/ceiling assembly or the ceiling membrane of a roof/ceiling assembly shall comply with Sections 714.4.1.1 through 714.4.1.4. Penetrations in horizontal smoke barriers shall also comply with 714.5.~~

714.4.1 714.4.1.1 Through penetrations. Through penetrations of ~~fire-resistance-rated~~ horizontal assemblies shall comply with Section 714.4.1.1 or 714.4.1.2 ~~714.4.1.1.1~~ or ~~714.4.1.1.2~~. (exceptions to remain unchanged)

714.4.1.1 714.4.1.1.1 Installation. Through penetrations shall be installed as tested in the approved fire-resistance-rated assembly.

714.4.1.2 714.4.1.1.2 Through-penetration firestop system. Through penetrations shall be protected by an approved through-penetration firestop system installed and tested in accordance with ASTM E 814 or UL 1479, with a minimum positive pressure differential of 0.01 inch of water (2.49 Pa). The system shall have an F rating/T rating of not less than 1 hour but not less than the required rating of the floor penetrated.

Exceptions:

1. Floor penetrations contained and located within the cavity of a wall above the floor or below the floor do not require a T rating.
2. Floor penetrations by floor drains, tub drains or shower drains contained and located within the concealed space of a horizontal assembly do not require a T rating.

714.4.2 714.4.1.2 Membrane penetrations. Penetrations of membranes that are part of a horizontal assembly shall comply with Section 714.4.1.1 or 714.4.1.2 ~~714.4.1.1.1~~ or ~~714.4.1.1.2~~. Where floor/ceiling assemblies are required to have a fire-resistance rating, recessed fixtures shall be installed such that the required fire resistance will not be reduced.

(Portions of text not shown remain unchanged)

714.4.3 714.4.1.3 Dissimilar materials. Noncombustible penetrating items shall not connect to combustible materials beyond the point of firestopping unless it can be demonstrated that the fire-resistance integrity of the horizontal assembly is maintained.

714.4.4 714.5 Penetrations in smoke barriers. Penetrations in *smoke barriers* shall be protected by an approved *through-penetration firestop system* installed and tested in accordance with the requirements of UL 1479 for air leakage. The *L rating* of the system measured at 0.30 inch (7.47 Pa) of water in both the ambient temperature and elevated temperature tests, shall not exceed:

1. 5.0 cfm per square foot (0.025m³ / s · m²) of penetration opening for each *through-penetration firestop system*; or
2. A total cumulative leakage of 50 cfm (0.024m³/s) for any 100 square feet (9.3 m²) of wall area, or floor area.

714.5 714.4.2 Nonfire-resistance-rated assemblies. Penetrations of nonfire-resistance-rated floor or floor/ceiling assemblies or the ceiling membrane of a nonfire-resistance-rated roof/ceiling assembly shall meet the requirements of Section 713, or shall comply with Section 714.5.1 or 714.5.2 ~~714.4.2.1 or 714.4.2.2.~~

714.5.1 714.4.2.1 Noncombustible penetrating items. Noncombustible penetrating items that connect not more than five stories are permitted, provided that the annular space is filled to resist the free passage of flame and the products of combustion with an approved noncombustible material or with a fill, void or cavity material that is tested and classified for use in through-penetration firestop systems.

714.5.2 714.4.2.2 Penetrating items. Penetrating items that connect not more than two stories are permitted, provided that the annular space is filled with an approved material to resist the free passage of flame and the products of combustion.

Reason: The ICC Board established the ICC Code Technology Committee (CTC) as the venue to discuss contemporary code issues in a committee setting which provides the necessary time and flexibility to allow for full participation and input by any interested party. The code issues are assigned to the CTC by the ICC Board as "areas of study". Information on the CTC, including: meeting agendas; minutes; reports; resource documents; presentations; and all other materials developed in conjunction with the CTC effort can be downloaded from the following website: <http://www.iccsafe.org/cs/CTC/Pages/default.aspx>. Since its inception in April/2005, the CTC has held twenty two meetings - all open to the public.

This proposed change is a result of the CTC's investigation of vertical openings through the Vertical Opening Study Group, which is part of the area of study, entitled "Balanced Fire Protection." The scope of the activity is noted as:

"To investigate what constitutes an acceptable balance between active fire protection and passive fire protection measures with respect to meeting the fire and life safety objectives of the IBC."

This proposal reorganizes some sections of Chapter 7 in order to clarify the provisions for protection of vertical openings. In the last code cycle, FS56-09/10 removed some inconsistencies, conflicts and obsolete language in Chapter 7, and eliminated some "do loops" that sent the code user in circles. This code change continues to take the code in the direction established by FS56. As with FS56-09/10, these proposed changes are editorial in nature and will not change how the code is applied. The primary change is to distinguish the different functions of Sections 711 and 712. Section 711 will contain only provisions for construction of horizontal assemblies and floor assemblies; Section 712 will contain all the initial provisions for vertical openings. In the 2012 IBC, Section 711 has a mixture of provisions related to assembly construction and to protection of vertical openings. In this proposal, all those provisions related to vertical openings are relocated to Section 712.

This proposal corrects an inconsistency in Section 711 with regard to non-rated floor and roof assemblies. The charging language in Section 711.1 of the 2012 code says that only rated horizontal assemblies are required to comply with Section 711; non-rated floor and roof assemblies are required to comply only with Section 714.4.2. However, Section 711.4.1 is titled "nonfire-resistance-rated assemblies" and contains provisions that are meant to apply to non-rated assemblies. This proposal corrects that anomaly by dividing Section 711 into separate subsections for rated and nonrated assemblies, and revising Section 711.1 to state that non-rated assemblies are required to comply with 711.3.

The specific changes include the following.

Sec. 711.1: The charging language is revised to clarify that rated assemblies are required to comply with Section 711.2 ("Horizontal assembly" is defined in Chapter 2 as "a fire-resistance-rated floor or roof assembly ..."). Nonrated assemblies are required to comply with Section 711.3.

Sec. 711.2: A new subsection is created that applies only to rated horizontal assemblies. The provisions of Section 711.3 through 711.3.2 are separated into subsections with no change to the requirements. New subsections 711.2.4.4, 711.2.4.5 and 711.2.4.6 are added so that all the requirements for fire-resistance rating of horizontal assemblies are included in 711.

711.2.2 & 711.2.3: The language currently found in Section 711.4. Continuity, is moved closer to the beginning of the section and divided into two subsections to draw attention to the fact that the two provisions deal with separate subjects.

711.3.2 (2012 IBC): This section is being moved to Section 712 (712.1.13) because it applies to a vertical opening rather than a horizontal or floor assembly.

711.3: A new subsection is created that includes basic provisions for non-rated assemblies.

Sec. 711.4 (2012 IBC): The first sentence is relocated to new Section 711.2.1. The sentence that addresses skylights is moved to Section 712 (712.1.15) because it applies to a vertical opening rather than a horizontal or floor assembly. The last sentence and the exception are relocated to new Section 711.2.3.

Secs 711.5-711.8: All these sections pertain to protection of vertical openings and are relocated to Section 712.

Sec. 711.9: The provisions related to elevator lobbies are moved to Section 713.14 except the last sentence which is deleted because it is covered by Section 712.

Sec. 712.1: The charging language is revised to state more clearly that all vertical openings are required to be protected with one of the methods described in Section 712.

Sec. 712.1.5: 2012 Section 711.4.1 is relocated to 712 because it pertains to protection of vertical openings.

Sec. 712.1.10: The provisions related to vertical openings in parking garages are collected in this section. 712.1.10.1 is taken from current Sec. 712.1.9; 712.1.10.2 is taken from current Sec. 714.1.15; and 712.1.10.3 is taken from current Sec. 712.1.16.

Sec. 712.1.11: The current section moved to Section 712.1.5.

Sec. 712.1.13: Provisions related to opening protectives are collected together in new subsections. Sec. 712.1.13.1 relocated the provisions for floor fire door assemblies from current Sec. 711.8; Sec. 712.1.13.2 is relocated from current Sec. 711.3.2.

Sec. 712.1.15: A portion of current Sec. 711.4 is relocated here.

Sec. 713.14.1: This section is revised to accommodate provisions currently found in Section 711.9. Lobbies will still be required in most buildings only if there are more than 3 stories. However, the 3-story limitation is moved to an exception in order to incorporate the provision from 711.9 that requires lobbies whenever an elevator penetrates a smoke barrier. The exception mentions Group I-2 and I-3 occupancies because that is where smoke barriers are used.

Sec. 714.4: Sec. 714.4 is separated into separate sections for horizontal assemblies and non-rated assemblies.

Cost Impact: This code change proposal will not increase the cost of construction.

FS50-12

Public Hearing:	Committee:	AS	AM	D
	Assembly:	ASF	AMF	DF

711-FS-BALDASSARRA-CTC

FS51 – 12

712.1.8, 1009.3

Proponent: Al Godwin, CBO, CPM, representing Aon Fire Protection Engineering (al.godwin@aon.com)

Revise as follows:

712.1.8 Two-story openings. In other than Groups I-2 and I-3, a floor opening that is not used as one of the applications listed in this section shall be permitted if it complies with all of the items below.

1. Does not connect more than two adjacent stories.
2. Does not contain a stairway or ramp required by Chapter 10.
3. Does not penetrate a horizontal assembly that separates fire areas or smoke barriers that separate smoke compartments.
4. Is not concealed within the construction of a wall or a floor/ceiling assembly.
5. Is not open to a corridor in Group I and R occupancies.
6. Is not open to a corridor on nonsprinklered floors.
7. Is separated from floor openings and air transfer openings serving other floors by construction conforming to required shaft enclosures.

1009.3 Exit access stairways. Floor openings between stories created by exit access stairways shall be enclosed.

Exceptions:

1. In other than I-2 and I-3 occupancies, *exit access stairways* that serve, or atmospherically communicate between, only two adjacent stories are not required to be enclosed.
2. Exit access stairways serving and contained within a single residential dwelling unit or sleeping unit in Group R-1, R-2 or R-3 occupancies are not required to be enclosed.
3. In buildings with only Group B or M occupancies, exit access stairway openings are not required to be enclosed provided that the building is equipped throughout with an automatic sprinkler system in accordance with Section 903.3.1.1, the area of the floor opening between stories does not exceed twice the horizontal projected area of the exit access stairway, and the opening is protected by a draft curtain and closely spaced sprinklers in accordance with NFPA 13.
4. In other than Group B and M occupancies, exit access stairway openings are not required to be enclosed provided that the building is equipped throughout with an automatic sprinkler system in accordance with Section 903.3.1.1, the floor opening does not connect more than four stories, the area of the floor opening between stories does not exceed twice the horizontal projected area of the exit access stairway, and the opening is protected by a draft curtain and closely spaced sprinklers in accordance with NFPA 13.

Reason: Section 712.1.8: As written, it would allow a multi-story shaft with an opening at the bottom floor and at the top floor, but not the intermediate floors. While the shaft is only open to two stories, it creates a multi-story shortcut.

Section 1009.3: As written, the phrase “atmospherically communicate” would allow a multi-story shaft with an opening at the bottom floor and at the top floor, but not the intermediate floors. While the shaft is only open to two stories, it creates a multi-story shortcut.

Cost Impact: This code change proposal will not increase the cost of construction.

FS51-12

Public Hearing:	Committee:	AS	AM	D
	Assembly:	ASF	AMF	DF

712.1.8-FS-GODWIN

FS52 – 12

707.5.1, 713.1, 909.20

Proponent: Philip Brazil, Reid Middleton, Inc., representing Washington Association of Building Officials, Technical Code Development Committee (pbrazil@reidmiddleton.com)

Revise as follows:

707.5.1 Supporting construction. The supporting construction for a *fire barrier* shall be protected to afford the required *fire-resistance rating* of the *fire barrier* supported. Hollow vertical spaces within a *fire barrier* shall be fireblocked in accordance with Section 718.2 at every floor level.

Exceptions:

1. The maximum required *fire-resistance rating* for assemblies supporting a *fire barrier* separating tank storage as provided in Section 415.8.2.1 shall be 2 hours, but not less than required by Table 601 for the building construction type.
2. Shaft enclosures shall be permitted to terminate at a top enclosure complying with Section 713.12.
3. Supporting construction for 1-hour *fire barriers* required by Table 509 in buildings of Type IIB, IIIB and VB construction is not required to be fire-resistance rated unless required by other sections of this code.
4. Interior exit stairway and ramp enclosures required by Section ~~4022.2~~ 1009.2.2 and exit access stairway and ramp enclosures required by Section 1009.3 shall be permitted to terminate at a top enclosure complying with Section 713.12.

713.1 General. The provisions of this section shall apply to shafts required to protect openings and penetrations through floor/ceiling and roof/ceiling assemblies. Exit access stairways and exit access ramps shall be ~~protected~~ enclosed in accordance with the ~~applicable provisions of~~ Sections 1009.3 and 1010.2, respectively. Interior exit stairways and interior exit ramps shall be ~~protected~~ enclosed in accordance with ~~the requirements of~~ Section ~~4022~~ 1009.2.2.

Revise as follows:

909.20 Smokeproof enclosures. Where required by Section 1022.10, a *smokeproof enclosure* shall be constructed in accordance with this section. A *smokeproof enclosure* shall consist of an ~~enclosed interior exit stairway~~ that ~~conforms to~~ is enclosed in accordance with the applicable provisions of Section ~~4022.2~~ 1022 and an open exterior balcony or ventilated vestibule meeting the requirements of this section. Where access to the roof is required by the *International Fire Code*, such access shall be from the smokeproof enclosure where a smokeproof enclosure is required.

Reason: The changes are made because Sections 1009.2.2 and 1010.2 require the enclosure of interior exit stairways and ramps, respectively. Section 1022, however, does not require their enclosure but does specify the technical provisions for their enclosure (e.g., Sections 1022.2, 1022.4, 1022.5 and 1022.7). The changes in Section 909.20 are also being made for consistency with similar language in Section 1010.2. Based on our analysis of the 2012 IBC, all references to the enclosure of interior exit stairways and ramps where similar changes are warranted are included in this proposal.

Cost Impact: The code change proposal will not increase the cost of construction.

FS52-12

Public Hearing:	Committee:	AS	AM	D
	Assembly:	ASF	AMF	DF

707.5.1-FS-BRAZIL

FS53 – 12

713.4

Proponent: Barry Gupton, PE, NC Department of Insurance, Office of State Fire Marshal, Engineering Division (barry.gupton@ncdoi.gov)

Revise as follows:

713.4 Fire-resistance rating. Shaft enclosures shall have a fire-resistance rating of not less than 2 hours where connecting four stories or more, and not less than 1-hour where connecting less than four stories. The number of stories connected by the shaft enclosure shall include any basements but not any mezzanines. ~~Shaft enclosures shall have a fire-resistance rating not less than the floor assembly penetrated, but need not exceed 2 hours. Where a shaft enclosure connects less than four stories and penetrates floor assemblies rated for 2 hours or more the shaft enclosure shall have a fire-resistance rating of 2 hours.~~ Shaft enclosures shall meet the requirements of Section 703.2.1.

Reason: This is an editing correction to help clarify the intent of the code. The existing sentence concerning the penetration of rated floor assemblies is confusing and appears to contradict the beginning of the section. The intent is that the floor rating supersede the rating based on the number of connected floors if the floor assembly is rated greater than would be required by the number of floors connected. That only happens when you have a 2-hour or more rated floor assembly and less than 4 connected floors.

Cost Impact: The code change proposal will not increase the cost of construction.

FS53-12

Public Hearing:	Committee:	AS	AM	D
	Assembly:	ASF	AMF	DF

713.4-FS-GUPTON

FS54 – 12

713.8

Proponent: Tony Crimi, A.C. Consulting Solutions Inc, representing International Firestop Council (tcrimi@sympatico.ca)

Revise as follows:

713.8 Penetrations. Penetrations in a shaft enclosure shall be protected in accordance with Section 714 as required for *fire barriers*. Structural elements, such as beams or joists, where protected in accordance with Section 714 shall be permitted to penetrate a shaft enclosure provided the materials and methods of construction used to protect penetrations are designed to accommodate anticipated deflection of the structural elements under fire exposure.

Reason: In the last cycle, the IBC was revised to permit beams and other structural elements to penetrate a fire separation as long as the structural element is also protected. While this intent may be reasonable, special precautions must be taken to ensure that the methods and materials used to protect the through penetrations are designed to accommodate the deflection anticipated during tests of fire resistance rated assemblies or structural elements. Through penetration fire stop system used as described in 713.8 need to be designed to anticipate this level of deflection.

The 2011 edition of ASTM E119 now imposes maximum deflection criterion for evaluation of unrestrained beams for fire resistance rated horizontal assemblies. The maximum total deflection permitted is dependent upon the clear span of the beam, and the distance between the extreme fiber of the beam in the compression and tensile zones. Other fire-resistance rated structural members do not include limits on maximum deflection or deflection rate. Even under non-fire conditions, the Code permits a prescribed maximum deflection.

Deflections of 6 to 8 inches are not uncommon when conducting fire-resistance tests on load-bearing structural elements or assemblies. Consequently, this proposal requires designers to take into account anticipated deflections when structural elements penetrate a shaft.

Cost Impact: This proposal does not increase the cost of construction.

FS54-12

Public Hearing:	Committee:	AS	AM	D
	Assembly:	ASF	AMF	DF

713.8-FS-CRIMI

FS55 – 12

713.11

Proponent: Sharon S. Gilyeat, Koffel Associates, Inc., representing CHUTES International

Revise as follows:

713.11 Enclosure at the bottom. Shafts that do not extend to the bottom of the building or structure shall comply with one of the following:

1. They shall be enclosed at the lowest level with construction of the same *fire-resistance rating* as the lowest floor through which the shaft passes, but not less than the rating required for the shaft enclosure.
2. They shall terminate in a room having a use related to the purpose of the shaft. The room shall be separated from the remainder of the building by *fire barriers* constructed in accordance with Section 707 or *horizontal assemblies* constructed in accordance with Section 711, or both. The *fire-resistance rating* and opening protective shall be at least equal to the protection required for the shaft enclosure.
3. They shall be protected by *approved fire dampers* installed in accordance with their listing at the lowest floor level within the shaft enclosure.

Exceptions:

1. The fire-resistance-rated room separation is not required, provided there are no openings in or penetrations of the shaft enclosure to the interior of the building except at the bottom. The bottom of the shaft shall be closed off around the penetrating items with materials permitted by Section 718.3.1 for draftstopping, or the room shall be provided with an *approved automatic sprinkler system*.
2. A shaft enclosure containing a ~~refuse chute or laundry waste or linen chute~~ shall not be used for any other purpose and shall ~~terminate discharge~~ in a room protected in accordance with Section 713.13.4.
3. The fire-resistance-rated room separation and the protection at the bottom of the shaft are not required provided there are no combustibles in the shaft and there are no openings or other penetrations through the shaft enclosure to the interior of the building.

Reason: Editorial changes intended to use consistent terms throughout the ICC that correlate with NFPA 82.

Cost Impact: The code change proposal will not increase the cost of construction.

FS55-12

Public Hearing:	Committee:	AS	AM	D
	Assembly:	ASF	AMF	DF

713.11-FS-GILYEAT

FS56 – 12

713.13

Proponent: Robert Marshall, Contra Costa Fire Department, representing CalChiefs (rmars@cccfd.org); Adria Paesani, Fountain Valley Fire Department, representing CalChiefs

Revise as follows:

713.13 Refuse and laundry chutes. Refuse, Recycling, and Laundry Chutes shall meet the requirements of NFPA 82 and 713.13.1 through 713.13.6.

Exceptions:

1. Chutes serving and contained within a single dwelling unit.
2. ~~Refuse and laundry chutes in Group I-2 shall comply with the provisions of NFPA 82, Chapter 5.~~

Reason: During the last code cycle, a code change was submitted and approved to add the use of NFPA 82 for trash and linen chutes in I-2 occupancies. There was a conflict between the IBC and other non-ICC regulations that created conflicts causing problems during the accreditation process. During the committee hearings, some committee members stated that it would be better to make the requirement to use NFPA 82 across the board to avoid confusion. This code change proposal does exactly that.

NFPA 82 is more robust than the current requirements found in the IBC, though several items in the IBC are more restrictive than NFPA 82, so those items remain.

Referenced Standards: NFPA 82, 2009 edition

Cost Impact: This will increase the cost of construction

FS56-12

Public Hearing:	Committee:	AS	AM	D
	Assembly:	ASF	AMF	DF

713.13-FS-MARSHALL-PAESANI

FS57 – 12

713.13.1

Proponent: Sharon S. Gilyeat, Koffel Associates, Inc., representing CHUTES International

Revise as follows:

713.13.1 Refuse, recycling and laundry chute enclosures. A shaft enclosure containing a refuse, recycling, or laundry chute shall not be used for any other purpose and shall be enclosed in accordance with Section 713.4. Openings into the shaft, including those from access rooms and termination rooms, shall be protected in accordance with this section and Section 716. Openings into chutes shall not be located in *corridors*. Doors into chutes shall be self-closing. Discharge doors shall be self- or automatic-closing upon the actuation of a smoke detector in accordance with Section 716.5.9.3, except that heat-activated closing devices shall be permitted between the shaft and the termination room.

Reason: The industry standard is for the loading doors to remain normally closed and in the case of linen, access may also be secured. Allowing a loading door to a chute to be held open creates a safety risk. The risk of someone falling into the chute inadvertently is minimized by the door being normally closed. This section specifically refers to the doors to the chute from the access or discharge room. It does not refer to doors to the rooms associated with a chute. The proposed change only affects chute loading doors. It still requires all chute doors to be self-closing. The changes did not affect discharge doors which would be allowed to be held-open and obviously do not create the same safety risk. It should be noted that even the proponent of FS 39 acknowledged in their proposal that chute loading doors should not be held open even if they are automatic closing.

Cost Impact: The code change proposed will not increase the cost of construction.

FS57-12

Public Hearing:	Committee:	AS	AM	D
	Assembly:	ASF	AMF	DF

713.13.1-FS-GILYEAT

FS58 – 12

713.13.2

Proponent: John D. Nicholas, Perceptive Solutions LLC, representing Unifrax I LLC
(john@perceptivesolutionsllc.com)

THIS IS A 5 PART CODE CHANGE. ALL PARTS WILL BE HEARD BY THE IBC FIRE SAFETY COMMITTEE. SEE THE TENTATIVE HEARING ORDER FOR THIS COMMITTEE.

PART I – IBC FIRE SAFETY

Revise as follows:

713.13.2 Materials. A shaft enclosure containing a refuse, recycling, or laundry chute shall be constructed of materials as permitted by the building type of construction or use a tested and listed fire resistive metallic duct system in compliance with ASTM E2816-11, which has a fire-resistance rating required by the building type of construction.

Add new standard to Chapter 35 as follows:

ASTM E2816-11, Standard Test Methods for Fire Resistive Metallic HVAC Duct Systems.

PART II – IBC FIRE SAFETY

Revise as follows:

909.10.3 Fire-resistive Metallic Duct System. Ducts used in compliance with Section 909.10.2 that penetrate fire-resistance rated wall assemblies or *horizontal assemblies* shall be tested and listed in accordance with ASTM E2816-11.

Exception: Where the installation of a *smoke or fire damper* will not interfere with the operation of a required smoke control system in accordance with Section 909, penetrations by ducts and air transfer openings are permitted to comply with Section 717.

Add new standard to Chapter 35 as follows:

ASTM E2816-11, Standard Test Methods for Fire Resistive Metallic HVAC Duct Systems.

PART III – IBC FIRE SAFETY

Add new text as follows:

909.20.5.1 Stair Pressurization Ducts. Ducts used to supply the air for pressurization of interior *exit stairways* shall be protected using systems tested and listed in accordance with ASTM E2816-11 or comply with Section 713.

Add new standard to Chapter 35 as follows:

ASTM E2816-11, Standard Test Methods for Fire Resistive Metallic HVAC Duct Systems.

PART IV – IBC FIRE SAFETY

Revise as follows:

909.20.6.1 Ventilation systems. Smokeproof enclosure ventilation systems shall be independent of other building ventilation systems. The equipment, control wiring, power wiring and ductwork shall comply with one of the following:

1. Equipment, control wiring, power wiring and ductwork shall be located exterior to the building and directly connected to the smokeproof enclosure or connected to the smokeproof enclosure by ductwork enclosed by not less than 2-hour *fire barriers* constructed in accordance with Section 707 or *horizontal assemblies* constructed in accordance with Section 711, or both; or use a tested and listed fire resistive metallic duct system in compliance with ASTM E2816-11 as the ductwork or as an enclosure for equipment, control wiring, power wiring, or for both ductwork and enclosure purposes.
2. Equipment, control wiring, power wiring and ductwork shall be located within the smokeproof enclosure with intake or exhaust directly from and to the outside or through ductwork enclosed by not less than 2-hour *fire barriers* constructed in accordance with Section 707 or *horizontal assemblies* constructed in accordance with Section 711, or both; or use a tested and listed fire resistive metallic duct system in compliance with ASTM E2816-11 as the ductwork or as an enclosure for equipment, control wiring, power wiring, or for both ductwork and enclosure purposes.
3. Equipment, control wiring, power wiring and ductwork shall be located within the building if separated from the remainder of the building, including other mechanical equipment, by not less than 2-hour *fire barriers* constructed in accordance with Section 707 or *horizontal assemblies* constructed in accordance with Section 711, or both; or use a tested and listed fire resistive metallic duct system in compliance with ASTM E2816-11 as the ductwork or as an enclosure for equipment, control wiring, power wiring, or for both ductwork and enclosure purposes.

Add new standard to Chapter 35 as follows:

ASTM E2816-11, Standard Test Methods for Fire Resistive Metallic HVAC Duct Systems.

PART V – IBC FIRE SAFETY

Revise as follows:

909.21.3 Ducts for system. Any duct system that is part of the pressurization system shall be protected with the same *fire-resistance rating* as required for the elevator shaft enclosure.

Exception: Ducts tested and *listed* for not less than 2-hour fire-resistance in accordance with ASTM E2816-11.

Add new standard to Chapter 35 as follows:

ASTM E2816-11, Standard Test Methods for Fire Resistive Metallic HVAC Duct Systems.

Reason: (All Parts) These proposed code changes allow for the use of either a pre-fabricated duct system or field applied enclosure system. *ASTM E2816-11, Standard Test Methods for Fire Resistive Metallic HVAC Duct Systems* is a full consensus test method that was specifically designed to assess both specific end use of the ductwork and its protection materials.

ASTM E2816-11 provides tests for all four (4) possible duct system's configurations: Conditions A, B, C, and D. The application of these Conditions can be applied to specific types of duct system's use within a building. ASTM E2816 uses the ASTM E119 time-temperature curve and replicates use of exhaust by using a fan technique to create a negative pressure within the duct similar to that occurring while a cloth's drier exhaust system is in use. This method of tests also assesses both an internal and external fire threat to the duct as well as the transition or connection of horizontal ducts to vertical ducts. In ASTM E2816, the systems supports are also tested as part of the fire resistance test. ASTM E2816 offers the following tests to assess performance:

This method of tests uses the ASTM E119 time-temperature curve to test the ductwork and the enclosure materials. The Standard can evaluate the fire performance of HVAC ducts for both supply (pressurization) and return air, in the vertical and horizontal

orientation, with or without openings. This method of tests also assesses both an internal and external fire threat to the duct as well as the transition or connection of horizontal ducts to vertical ducts.

ASTM E2816 References
1.4.1 <i>Condition A</i> —These test methods provide a means for evaluating a horizontal HVAC duct system, without openings exposed to fire, passing through a vertical fire-separating element.
1.4.2 <i>Condition B</i> —These test methods provide a means for evaluating a vertical HVAC duct system, without openings exposed to fire and outfitted with a horizontal connection, passing through a horizontal fire-separating element.
1.4.3 <i>Condition C</i> —These test methods provide a means for evaluating a horizontal HVAC duct system, with unprotected openings exposed to fire, passing through a vertical fire-separating element.
1.4.4 <i>Condition D</i> —These test methods provide a means for evaluating a vertical HVAC duct system with a horizontal connection, and with unprotected openings exposed to fire, passing through a horizontal fire-separating element.

The new ASTM Standard evaluates the HVAC duct systems for surface burning characteristics, non-combustibility, fire resistance, durability, and fire engulfment with horizontal and vertical through-penetration firestops. ASTM E2816-11 also contains provisions for testing other service attributes of the duct system. ASTM E84 is used for the system's flame spread and smoke developed indices; ASTM E136 is used for insulation's non-combustibility; ASTM C518 is used for the insulation's durability; ASTM E814 is used for the system's ability as a firestop to prevent the spread of fire from compartment to compartment; ASTM E2226 is used for the resistance to the application of a hose stream; and ASTM C411 is used for the insulation covering's and lining's ability to resist flaming, glowing, smoldering or smoking while in service, which was just approved in December 2011 and this test method will also become part of the standard upon its latest publication.

ICC-ES AC179, *Acceptance Criteria for Metallic HVAC Duct Enclosure Assemblies*, cites ASTM E2816-11 to establish requirements for fire protection enclosure systems, applied to metallic HVAC ducts, which provide an alternate to required fire-resistance-rated shafts or an alternate to required fire dampers in specific locations, as well as to determine the characteristics of the system and enclosure material currently cited in the codes. This criteria provides an alternate to shaft enclosures for vertical ducts, and an alternate to fire dampers in horizontal ducts (penetrating fire barriers, fire partitions, and or smoke barriers) and vertical ducts connecting multiple stories

These comments are respectfully submitted as the ASTM Task Group Chair of ASTM E2816 who drafted its first version, as the proponent of the latest approved revisions to ICC ES AC179 *Acceptance Criteria For Metallic HVAC Duct Enclosure Assemblies*, as the ANSI Designated Expert to ISO TC92 Fire SC2 Fire Resistance WG4 that created and maintains ISO 6944 *Fire Containment — Elements of Building Construction — Part 1: Ventilation Ducts* and one who has designed, supervised, and overseen HVAC fire tests as a member of an international laboratory as well as the one who had jurisdiction over the product certification process for products and materials.

(Part I) This proposed code change allows for the use of HVAC duct systems in lieu of minimum 2-hour *fire barriers* constructed in accordance with Section 707 or *horizontal assemblies* constructed in accordance with Section 711, or both, when these ductwork systems are tested and listed in accordance with ASTM E2816-11.

The history of many provisions in our building codes are traced back to ASTM E119 as it is the oldest fire-resistance standard cited in the U.S. building codes. However, when fire test standards are developed for specific material applications those test standards replaced ASTM E119. There are many examples of advancements in fire testing being used to provide a fire test based on ASTM E119 but specifically developed for a particular application: doors, windows, firestop systems, joint systems, etc. For example, doors were tested to ASTM E119, then ASTM E152, and now to UL10b and 10c, which were developed to assess the door's fire performance in a specific application. As products are in service for prolonged periods of time some performance limitations are noted and addressed by industry and the codes. This proposed code change is a cost effective method of providing a test specifically designed to test the duct system as the shaft is not tested as constructed in the field but rather as a wall panel. ASTM E119 does not have a protocol for testing shafts that can be engulfed in a fire. The fire-resistance engulfment test of ASTM E2816 is a much more serve test scenario for a shaft or duct system as the volume of air within the shaft or duct is limited and will heat faster than the ambient laboratory air in contact with the wall panel. Also, the stability of the shaft as constructed in the field will react differently than a wall panel. The corners of the shaft will be tested as the sides of the shaft create stresses on the corners that are not evaluated by the ASTM E119 wall panel, which is secured into a test frame. Using tests designed to address the actual construction and application of materials is more conservative and usually increases life safety. Further, sometimes newer fire tests of materials allow more cost effective materials and construction than materials assessed by traditional tests not specifically designed to address their actual construction and application.

A recent laundry chute fire occurred September 5, 2011 in the Fenway Apartment building. "Dozens of college students were forced out of their apartments early Monday morning after fire swept through their building. The fire started in a laundry chute in the basement and burned all the way up to the roof.

The alarms started going off at around 2:30 a.m. in a six-story building at Westland Avenue and Hemenway Street in the Fenway section of the city. About 45 people, most of them students at The Boston Conservatory and the Berklee College of Music, scrambled to safety. No one was hurt. "A huge loud alarm went off and we all ran and our landlord was like, just get out as soon as you can and run. Honestly, it looked like it could have been so bad. It was just out of control," resident Jenna Schoen told WBZ NewsRadio 1030. The fire started in a laundry chute in the basement and burned all the way up to the sixth floor and the roof. There's no word yet on the cause, but it is not considered suspicious. Damage is estimated at \$400,000. Residents may not be able to move back in for weeks.^{1"}



(Image courtesy: Mark Corsillo)

This method of tests also assesses both an internal and external fire threat to the ductwork (refer to the table below) as well as the transition or connection of horizontal ducts to vertical ducts. Fire resistive metallic duct systems tested and listed to ASTM E2816 may provide a higher degree of fire protection. Shaft enclosures tested to ASTM E119 are tested as panels, not shafts, and are not subjected to an engulfment scenario as are fire resistive metallic duct systems tested and listed to ASTM E2816.

Bibliography:

1. <http://boston.cbslocal.com/2011/09/05/dozens-of-college-students-escape-fenway-apartment-fire/>

(Part II) This proposal would require HVAC ducts installed as part of a required smoke control system to be protected by a tested and listed assembly conforming to the new *ASTM E2816-11*, evaluated for the specific purpose. In addition, an exception to comply with section 717 is incorporated. This principle of protecting HVAC ducts used as part of a smoke control system from the effects of fire exposure is already contained in section 909.4 as part of a rational analysis supporting the design of smoke control systems to be employed. Section 909.4.4 requires that the design shall consider the effects of the heating, ventilating and air-conditioning (HVAC) systems on both smoke and fire transport. The analysis must include all permutations of systems status, and the design shall consider the effects of the fire on the HVAC systems.

This test is now also referenced as part of ICC-ES AC179. These standards (ASTM E2816-11 and AC179) evaluate the ability of a HVAC duct system to resist the spread of fire from one compartment to another compartment separated by fire resistance rated construction when the HVAC duct system is exposed to fire from the outside of the horizontal or vertical HVAC duct system, or from the outside with hot gases entering the inside of the HVAC duct system from unprotected openings, when subjected to the standard time-temperature curve of ASTM E119.

(Part III) A means of egress is designed to evacuate occupants from endangered areas as quickly and efficiently as possible. It is based on such factors as number of occupants, occupant densities, and occupant characteristics (such as physical size, need for personal space, and walking speed) to meet the desired flow rates for efficient evacuation (Fire Protection Handbook 1986). A number of evacuation drills have been conducted in multi-story buildings to develop models for predicting egress times and to assess the problems encountered during evacuation (Kagawa et al. 1985; Kendik 1986; Maclennan 1985; Melinek 1975; Pauls 1975, 1977, 1980a, and 1980b). The two methods of planned evacuation are uncontrolled total evacuation, where building occupants attempt to evacuate at the same time, and controlled selective evacuation, where the building occupants evacuate under instruction from a public address system. The results of an evacuation drill using each method are compared by Pauls (1980a).¹

The evacuating occupants require a habitable environment in order to facilitate their egress. If the ducts used to supply the air for pressurization of interior *exit stairways* are exposed to fire, the pressurized air may become super-heated creating an intolerable environment that impedes or prohibits the evacuating occupants egress.

ASTM E2816 uses the ASTM E119 time-temperature curve and by using a fan technique to create pressure within the duct similar to that occurring while a pressurization system is in use. Further, the intent of a pressurization system is two-fold: to provide a positive pressure atmosphere and a tenable environment for egress of occupants as referenced above. Allowing the pressurized air to become super-heated may create a life safety issue detrimental to the occupants during egress. Further, an unprotected duct system is susceptible to the effects of fire that may nullify or disrupt its intended use. Using tested and listed fire resistive metallic duct systems or shaft enclosures provides a pressurized air supply that is not supplying super-heated air.

ASTM E2816 is in concert with the requirements outlined in Section 909.4 and its subsections concerned with the requirement for a rational analysis supporting the types of smoke control systems to be employed, their methods of operation, the systems supporting them and the methods of construction to be utilized.

Bibliography:

1. Tamura, G.T., *Stair Pressurization Systems for Smoke Control: Design Considerations*, ASHRAE Transactions, 1989, Vol. 95, Pt. 2, 9p.

(Part IV) ASTM E2816 is in concert with the requirements outlined in Section 909.4 and its subsections. This method of tests also assesses both an internal and external fire threat to the ductwork (refer to the table below) as well as the transition or connection of horizontal ducts to vertical ducts, which supplements the requirements cited in Section 909.10.2. Fire resistive metallic duct systems

tested and listed to ASTM E2816 may provide a higher degree of fire protection. Construction tested to ASTM E119 are tested as panels and are not subjected to an engulfment scenario as are fire resistive metallic duct systems tested and listed to ASTM E2816.

(Part V) A means of egress is designed to evacuate occupants from endangered areas as quickly and efficiently as possible. It is based on such factors as number of occupants, occupant densities, and occupant characteristics (such as physical size, need for personal space, and walking speed) to meet the desired flow rates for efficient evacuation (Fire Protection Handbook 1986). A number of evacuation drills have been conducted in multi-story buildings to develop models for predicting egress times and to assess the problems encountered during evacuation (Kagawa et al. 1985; Kendik 1986; MacLennan 1985; Melinek 1975; Pauls 1975, 1977, 1980a, and 1980b). The two methods of planned evacuation are uncontrolled total evacuation, where building occupants attempt to evacuate at the same time, and controlled selective evacuation, where the building occupants evacuate under instruction from a public address system. The results of an evacuation drill using each method are compared by Pauls (1980a).¹

The evacuating occupants require a habitable environment in order to facilitate their egress. If the ducts used to supply the air for pressurization are exposed to fire, the pressurized air may become heated creating an intolerable environment that impedes or prohibits the evacuating occupants egress.

Refer to Part III for additional rationale also relevant to Part V.

Bibliography:

1. Tamura, G.T., *Stair Pressurization Systems for Smoke Control: Design Considerations*, ASHRAE Transactions, 1989, Vol. 95, Pt. 2, 9p.

Cost Impact: This change will potentially reduce the cost of construction.

Analysis: FS58, Part I and FS 59 propose provisions for fire resistive metallic duct systems. The committee needs to make its intent clear with respect to these provisions. FS58, Part II and FS 135 contain similar requirements for ducts that form smoke control systems. The committee needs to make its intent clear with respect to these provisions. FS58, Part III and FS 136 contain similar requirements for stair pressurization ducts. The committee needs to make its intent clear with respect to these provisions. FS58, Part IV, FS 137 and FS139 contain similar requirements for smokeproof enclosure ventilation systems. The committee needs to make its intent clear with respect to these provisions. FS58, Part V and FS 142 contain similar requirements for elevator hoistway pressurization. The committee needs to make its intent clear with respect to these provisions. A review of the standard proposed for inclusion in the code, ASTM E2816-11 with regard to the ICC criteria for referenced standards (Section 3.6 of CP#28) will be posted on the ICC website on or before April 2, 2012.

FS58-12

PART I – IBC FIRE SAFETY

Public Hearing:	Committee:	AS	AM	D
	Assembly:	ASF	AMF	DF

PART II – IBC FIRE SAFETY

Public Hearing:	Committee:	AS	AM	D
	Assembly:	ASF	AMF	DF

PART III – IBC FIRE SAFETY

Public Hearing:	Committee:	AS	AM	D
	Assembly:	ASF	AMF	DF

PART IV – IBC FIRE SAFETY

Public Hearing:	Committee:	AS	AM	D
	Assembly:	ASF	AMF	DF

PART V – IBC FIRE SAFETY

Public Hearing:	Committee:	AS	AM	D
	Assembly:	ASF	AMF	DF

713.13.2-FS-NICHOLAS-909.10.3 (NEW)-FS-NICHOLAS-909.20.5.1 (NEW)-FS-NICHOLAS-909.20.6.1 (NEW)-FS-NICHOLAS-909.21.3-FS-NICHOLAS (2)

FS59 – 12

713.13.2, Chapter 35

Proponent: Tony Crimi, A.C. Consulting Solutions Inc, representing International Firestop Council (tcrimi@sympatico.ca)

Revise as follows:

713.13.2 Materials. A shaft enclosure containing a refuse, recycling, or laundry chute shall be constructed of materials as permitted by the building type of construction.

Exception: A vertical fire-resistance rated enclosure system that complies with the requirements of Condition B of ASTM E2816-11 is permitted to enclose a refuse, recycling, or laundry chute in lieu of a shaft enclosure complying with section 713.

Add new standard to Chapter 35 as follows:

ASTM E2816-11, Standard Test Methods for Fire Resistive Metallic HVAC Duct Systems.

Reason: This proposal permits an additional alternative to the requirement of section 713 for shaft enclosures around refuse, recycling, or laundry chutes where the chutes are contained within a tested and listed assembly conforming to Condition B of the new *ASTM E2816-11, Standard Test Methods for Fire Resistive Metallic HVAC Duct Systems* evaluated for the specific purpose.

The test method evaluate the ability of an enclosure system to resist the spread of fire from one compartment to other compartments separated by a fire resistance rated construction when the HVAC duct system is exposed to fire under one or more of the following conditions:

- Condition A*— Fire exposure from the outside of the horizontal HVAC duct system without openings,
- Condition B*— Fire exposure from the outside of the vertical HVAC duct system without openings,
- Condition C*— Fire exposure from the outside with hot gases entering the inside of the horizontal HVAC duct system with unprotected openings, and
- Condition D*— Fire exposure from the outside with hot gases entering the inside of the vertical HVAC duct system with unprotected openings.

The new ASTM Standard evaluates the materials for surface burning characteristics, non-combustibility, fire resistance, durability, and fire engulfment with horizontal and vertical through-penetration firestops. The Standard can evaluate the fire performance in the vertical and horizontal orientation, with or without openings. These test methods evaluate the ability of an enclosure system to resist the spread of fire from one compartment to another compartment when subjected to the standard time-temperature curve of ASTM E119.

Cost Impact: This change will potentially reduce the cost of construction.

Analysis FS58, Part I and FS 59 propose provisions for fire resistive metallic duct systems. The committee needs to make its intent clear with respect to these provisions. A review of the standard proposed for inclusion in the code, ASTM E2816-11 with regard to the ICC criteria for referenced standards (Section 3.6 of CP#28) will be posted on the ICC website on or before April 2, 2012.

FS59-12

Public Hearing:	Committee:	AS	AM	D
	Assembly:	ASF	AMF	DF

713.3.2-FS-CRIMI

FS60 – 12

713.13, 713.13.1, 713.13.2, 713.13.3, 713.13.4

Proponent: Sharon S. Gilyeat, Koffel Associates, Inc., representing CHUTES International

Revise as follows:

713.13 Refuse Waste and laundry linen chutes and incinerator rooms. ~~In other than Group I-2, refuse and laundry chutes, access and termination rooms and incinerator rooms~~ Waste and linen chutes shall comply with the provisions of NFPA 82, Chapter 5 and shall meet the requirements of Sections 713.13.1 through 713.13.6. Incinerator rooms shall meet the provisions of 713.13.4 through 713.13.5.

Exceptions:

1. Chutes serving and contained within a single dwelling unit.
2. ~~Refuse and laundry chutes in Group I-2 shall comply with the provisions of NFPA 82, Chapter 5.~~

713.13.1 Refuse, recycling and laundry Waste and linen chute enclosures. A shaft enclosure containing a ~~refuse, recycling, or laundry waste or linen~~ chute shall not be used for any other purpose and shall be enclosed in accordance with Section 713.4. Openings into the shaft, ~~including those~~ from access rooms ~~and termination rooms~~, shall be protected in accordance with this section and Section 716. Openings into chutes shall not be located in corridors. Doors shall be self- or automatic-closing upon the actuation of a smoke detector in accordance with Section 716.5.9.3, except that heat-activated closing devices shall be permitted between the shaft and the termination room.

713.13.2 Materials. A shaft enclosure containing a refuse, recycling, or laundry chute shall be constructed of materials as permitted by the building type of construction.

713.13.3 Refuse, recycling and laundry Chute access rooms. Access openings for ~~refuse, recycling and laundry~~ waste or linen chutes shall be located in rooms or compartments enclosed by not less than 1-hour fire barriers constructed in accordance with Section 707 or horizontal assemblies constructed in accordance with Section 711, or both. Openings into the access rooms shall be protected by opening protectives having a fire protection rating of not less than 3/4 hour. Doors shall be self- or automatic-closing upon the detection of smoke in accordance with Section 716.5.9.3.

713.13.4 Chute termination discharge room. ~~Refuse, recycling and laundry~~ Waste or linen chutes shall discharge into an enclosed room separated from the remainder of the building by fire barriers with a fire resistance rating at least equal to the required fire-rating of the shaft enclosure and constructed in accordance with Section 707 or horizontal assemblies constructed in accordance with Section 711, or both. Openings into the ~~termination~~ discharge room from the remainder of the building shall be protected by opening protectives having a fire protection rating equal to the protection required for the shaft enclosure. Doors shall be self- or automatic-closing upon the detection of smoke in accordance with Section 716.5.9.3. ~~Refuse Waste~~ chutes shall not terminate in an incinerator room. ~~Refuse, recycling and laundry~~ Waste and linen rooms that are not provided with chutes need only comply with Table 509.

Reason: The proposed editorial code changes incorporated above are intended to bring the language of ICC more in line with industry standards by using the terms waste and linen, vs. rubbish, recycle, trash etc. These proposed terms are more generic, consistent and eliminate the need to distinguish between types of waste. Note that global changes have been submitted to the document to correct the terms in all locations and provide consistency. These terms are used inconsistently throughout the document. Note that during the last code cycle FS 191 was developed to clarify that recycling chutes are included in the requirements for chutes in IBC. This change was accepted by the committee and incorporated into the 2012 edition of the IBC. With the changes proposed herein, the IBC will rely mostly on NFPA 82 to regulate chute requirements and therefore the definition of a waste chute is better defined in that document. This change is not intended to relax the requirements; a recycling chute would still need to be protected like any other waste chute.

The technical changes are intended to have ICC incorporate NFPA 82 requirements for chutes for all occupancies not just for health care occupancies. NFPA 82, Chapter 5, was accepted as a reference standard chutes in health care occupancies during the last code cycle. The proposed technical changes also clarify that the fire resistance rating for the discharge room must have at least the same fire-rating as the shaft it serves.

It should be noted that during the committee's action on FS39 during the last cycle, many of the NFPA 82 requirements recommended by the proposer were not approved. The committee's reasoning indicated that they were not approved because the requirements were covered under NFPA 82 which was previously adopted by the committee. It is critical to understand that because the committee only adopted NFPA 82 for health care occupancies, there is still a void in the IBC. The requirements in NFPA 82 should apply to all commercial chutes. The changes proposed herein will fill that void.

Referencing NFPA 82 for all chutes will include required key construction and fire and life safety features that are currently not addressed by the IBC. Without this global adoption of NFPA 82 the following key requirements for chutes will not be covered in the IBC. These requirements have been extracted directly from NFPA 82 for easy reference and consideration by the committee.

1. Chute venting requirements:

5.2.2.4 Chute Venting.

5.2.2.4.1 A waste or linen chute shall extend (full size) at least 0.92m(3 ft) above the roof of a building of Type II-000, Type III, Type IV, or Type V construction.

5.2.2.4.2 The chute shall be permitted to extend less than 0.92m(3 ft) above the roof of a building of Type I, Type II-222, or Type II-111 construction subject to the approval of the authority having jurisdiction.

5.2.2.4.3 The chute shall be open to the atmosphere, with the opening being the same cross-sectional area as the chute.

5.2.2.4.4 The portion of chute between the highest intake door and the top of the chute vent shall be permitted to be offset a maximum of 45 degrees from the plumb, subject to the approval of the authority having jurisdiction.

2. Chute access and security

5.2* Gravity Waste or Linen Chutes.

5.2.1 General. General access gravity chutes shall be permitted to be supplied with unlocked doors and shall be permitted to be available to all occupants at all times.

5.2.1.1 Linen gravity chutes shall only be limited access chutes.

5.2.1.2 A limited access chute shall be secured either by locking the intake door or the entry door into the service room so that it can be used only by authorized personnel.

5.2.1.3 A gravity waste or linen chute also shall be permitted to be used to interface with a pneumatic transport system.

3. Minimum chute dimensions and offsets

5.2.2.2 Chute Offsets. See Figure 5.2.2.2.

5.2.2.2.1 Gravity metal chutes shall be constructed straight and plumb where allowed by the building configuration.

5.2.2.2.2 Gravity metal chutes shall be permitted to be offset a maximum of 15 degrees from plumb with the approval of the authority having jurisdiction.

5.2.2.2.3 Offsets shall be limited to a maximum of one offset for every two floors.

5.2.2.2.4 A single offset shall be completed (returned to vertical) between floors.

5.2.2.2.5 No access door shall be less than 1.2 m (4 ft) above an offset.

5.2.2.2.6 The portion of chute between the highest intake door and the chute termination shall be permitted to be offset a maximum of 45 degrees from the plumb, subject to the approval of the authority having jurisdiction.

5.2.2.2.7 For the purpose of this standard, a single chute offset from vertical shall include a return of the chute to vertical.

5.2.2.3 Standard Dimensions of Waste and Linen Gravity Chutes. Standard gravity chutes shall be a minimum of 571 mm (22 1/2 in.) by 571 mm (22 1/2 in.) or 610 mm (24 in.) in diameter.

4. Limitations on openings based on general vs secure access to the chute intake door

5.2.3.3 Chute Intake Doors.

5.2.3.3.1 General Access Gravity Waste Chutes.

5.2.3.3.1.1 All chute intake doors into a waste chute shall be provided with a self-closing, positive latching frame and gasketed fire door assembly having a fire protection rating of not less than 1 hour.

5.2.3.3.1.2 The door frame shall be fastened into the chute and the shaft wall.

5.2.3.3.1.3 The design and installation shall be such that no part of the frame or door projects into the chute.

5.2.3.3.1.4 The area of each chute intake door shall be limited to one-third of the cross-sectional area of a square chute and 44 percent of the area of a round chute.

5.2.3.3.2 Limited-Access Gravity Chutes.

5.2.3.3.2.1 All chute intake doors into a linen or waste chute shall be provided with a self-closing, positive-latching frame and gasketed fire door assembly having a fire protection rating of not less than 1 hour.

5.2.3.3.2.2 The door frame shall be fastened into the chute and the shaft wall.

5.2.3.3.2.3 The design and installation shall be such that no part of the frame or door projects into the chute.

5.2.3.3.2.4 A key shall be required to open the door.

5.2.3.3.2.5 The area of each waste chute intake door shall be limited to two-thirds of the cross-sectional area of the chute.

5.2.3.3.2.6 The area of each linen chute intake door shall not exceed the cross-sectional area of the chute.

There are other requirements that are critical for fire and life safety but these are the most significant ones that will be adopted if this change is incorporated. This change is critical to ensure fire and life safety in all commercial chutes in buildings. The industry is currently designing and installing chutes in accordance with this industry standard.

Cost Impact: The code change proposed will not increase the cost of construction.

FS60-12

Public Hearing:	Committee:	AS	AM	D
	Assembly:	ASF	AMF	DF

713.13-FS-GILYEAT

FS61 – 12

713.14.1, 3007 (New)

Proponent: Carl Baldassarra, P.E., FSFPE, Chair, ICC Code Technology Committee

Revise as follows:

713.14 Elevator, dumbwaiter and other hoistways. Elevator, dumbwaiter and other hoistway enclosures shall be constructed in accordance with Section 713 and Chapter 30.

Revise as follows:

SECTION 3007 **ELEVATOR LOBBIES**

3007.1 General. Enclosed elevator lobbies shall be provided in accordance with the following sections.

1. Section 3007.2 based upon number of stories connected by a shaft enclosure.
2. Section 405.4.3 for underground buildings.
3. Sections 407.5.3 and 711.9 for Group I-2 occupancies.
4. Section 1007.4 for areas of refuge.
5. Section 3008.7.2 for fire service access elevators.
6. Section 3009.7.2 for occupant evacuation elevators.

3007.2-713.14.1 Enclosed elevator lobby. An enclosed elevator lobby shall be provided at each floor where an elevator shaft enclosure connects more than three stories. The lobby enclosure shall separate the elevator shaft enclosure doors from each floor by fire partitions. In addition to the requirements in Section 708 for fire partitions, doors protecting openings in the elevator lobby enclosure walls shall also comply with Section 716.5.3 as required for corridor walls and penetrations of the elevator lobby enclosure by ducts and air transfer openings shall be protected as required for corridors in accordance with Section 717.5.4.1. Elevator lobbies shall have at least one means of egress complying with Chapter 10 and other provisions within this code.

Exceptions:

1. Enclosed elevator lobbies are not required at the level(s) of exit discharge, provided the level(s) of exit discharge is equipped with an automatic sprinkler system in accordance with Section 903.3.1.1.
2. Elevators not required to be located in a shaft in accordance with Section 712.1 are not required to have enclosed elevator lobbies.
3. Enclosed elevator lobbies are not required where additional doors are provided at the hoistway opening in accordance with Section 3002.6. Such doors shall comply with the smoke and draft control door assembly requirements in Section 716.5.3.1 when tested in accordance with UL 1784 without an artificial bottom seal.
4. Enclosed elevator lobbies are not required where the building is protected by an automatic sprinkler system installed in accordance with Section 903.3.1.1 or 903.3.1.2. This exception shall not apply to the following:
 - 4.1. Group I-2 occupancies;
 - 4.2. Group I-3 occupancies; and
 - 4.3. Elevators serving floor levels over 75 feet above the lowest level of fire department vehicle access in high-rise buildings.
5. Smoke partitions shall be permitted in lieu of fire partitions to separate the elevator lobby at each floor where the building is equipped throughout with an automatic sprinkler system installed in accordance with Section 903.3.1.1 or 903.3.1.2.

In addition to the requirements in Section 710 for smoke partitions, doors protecting openings in the smoke partitions shall also comply with Sections 710.5.2.2, 710.5.2.3, and 716.5.9 and duct penetrations of the smoke partitions shall be protected as required for corridors in accordance with Section 717.5.4.1.

6. Enclosed elevator lobbies are not required where the elevator hoistway is pressurized in accordance with Section 909.21.
7. Enclosed elevator lobbies are not required where the elevator serves only open parking garages in accordance with Section 406.5.

(Renumber subsequent sections)

Reason: This proposal is one of several proposals submitted by the CTC Elevator lobby SG. The ICC Executive Board directed the Code Technology Committee (CTC) to study the issue of elevator lobby separations in November 2010 due to the number of code change proposals submitted addressing this issue over a number of code change cycles. The Code Technology Committee formed a study group on the elevator lobby separation issue in December 2010. Note that this subject had been previously addressed by CABO/BCMC in 1986 with a similar conclusion. The code change proposals submitted are the result of the CTC's study of the issue. Note that the scope of the activity was as follows:

Scope

- Review the need for elevator lobbies, with emphasis on building use, building and hoistway height, active and passive fire protection features associated with the aforementioned.
- Review the differences and specific needs when dealing with elevator lobbies of traditional-use elevators, fire service elevators, and occupant evacuation elevators.
- Review related code provisions, such as egress from and through elevator lobbies.
- Review the appropriate use of alternatives including pressurization of hoistways, additional doors, roll-down style barriers, and gasketing systems.
- Review with members of elevator industry to scope the requirements of applicable elevator reference standards as it deals with elevator lobby design, use and construction.
- Review design and construction requirements for elevator lobbies, including but not limited to dimensions, location and separation.
- Review applicable code change history, technical studies and loss statistics as part of this review.

Based upon the extensive nature of this area of study, 5 Task Groups were formed during the process to provide in-depth review and to manage the number of issues. These task groups developed a number of proposals that were coordinated throughout the process.

More information on this CTC area of study can be found at the following link.
<http://www.iccsafe.org/cs/CTC/Pages/ElevatorLobbies.aspx>

The focus is relocation of the enclosed elevator lobby requirements in Section 713.14.1 to Chapter 30 of the IBC. This proposal is editorial in nature but is done with the hope of keeping the lobby requirements easier to apply and more consistent in the future. Section 405.4.3 contains the requirements for elevator lobbies in underground buildings. Sections 407.5.3 and 711.9 contain the requirements for elevator lobbies for the protection of horizontal assemblies in Group I-2 occupancies. The text in Section 713.14.1.1 has been relocated to new Section 3007.1 and editorially revised for consistency. Sections 3007.7.2 and 3008.7.2 (renumbered to 3008.7.2 and 3009.7.2 in this proposal) currently house the requirements for fire service access elevators and occupant evacuation elevators which have lobby construction requirements associated with them. New Section 3007.1 in this proposal now simply references users to the appropriate sections within the code for enclosed elevator lobby requirements. This way code users will be clear that there are several types of lobbies and that more than one set of requirements and triggers may apply to them. This also assists with correlation with ASME A17.1. (responsibility of committees needs to be addressed. Suggest that FS still address this new section 3007).

If this proposal should pass and FS##-12 (TG2 Prop1) should pass renumbering will be necessary to relocate the revised provisions from FS##-12(TG2 Prop1) to chapter 30. See discussion on CTC elevator lobby proposal coordination in code change FS##-12

Cost Impact: This code change proposal will not increase the cost of construction.

FS61-12

Public Hearing:	Committee:	AS	AM	D
	Assembly:	ASF	AMF	DF

713.14.1 #3-FS-Baldassarra-CTC

FS62 – 12

713.14.1

Proponent: Bob Eugene, representing Underwriters Laboratories (Robert.Eugene@ul.com)

Revise as follows:

713.14.1 Elevator lobby. An enclosed elevator lobby shall be provided at each floor where an elevator shaft enclosure connects more than three *stories*. The lobby shall separate the elevator shaft enclosure doors from each floor by *fire partitions*. In addition to the requirements in Section 708 for *fire partitions*, doors protecting openings in the elevator lobby enclosure walls shall also comply with Section 716.5.3 as required for *corridor walls*, ~~and~~ Such doors shall comply with the smoke and draft control door assembly requirements in Section 716.5.3.1 when tested in accordance with UL 1784 without an artificial bottom seal. Penetrations of the elevator lobby enclosure by ducts and air transfer openings shall be protected as required for *corridors* in accordance with Section 717.5.4.1. Elevator lobbies shall have at least one *means of egress* complying with Chapter 10 and other provisions within this code.

Exceptions: (No changes to current text)

Reason: The intent of this proposal is to clarify that the air leakage rate for smoke and draft control doors protecting openings in elevator lobby enclosure walls shall be determined without an artificial bottom seal. This proposal would bring consistency to the three code sections covering doors in elevator lobby enclosure walls. The other two sections containing similar requirements are Section 713.14.1 Exception 3, covering the additional doors provided at the hoistway openings, and Section 3007.7.3, covering doors in the fire services access elevator lobby.

Cost Impact: None

FS62-12

Public Hearing:	Committee:	AS	AM	D
	Assembly:	ASF	AMF	DF

713.14.1-FS-EUGENE

FS63 – 12

713.14.1

Proponent: Rick Kabele, CBO, CFM, CFPS; Building Safety Associates, LLC, representing self (rick@buildingsafetyassociates.com)

Revise as follows:

713.14.1 Elevator lobby. An enclosed elevator lobby shall be provided at each floor where an elevator shaft enclosure connects more than three *stories*. The lobby enclosure shall separate the elevator shaft enclosure doors from each floor by *fire partitions*. In addition to the requirements in Section 708 for *fire partitions*, doors protecting openings in the elevator lobby enclosure walls shall also comply with Section 716.5.3 as required for *corridor* walls and penetrations of the elevator lobby enclosure by ducts and air transfer openings shall be protected as required for *corridors* in accordance with Section 717.5.4.1. Elevator lobbies shall have at least one *means of egress* complying with Chapter 10 and other provisions within this code.

Exceptions:

1. Enclosed elevator lobbies are not required at the level(s) of *exit discharge*, provided the level(s) of *exit discharge* is equipped with an *automatic sprinkler system* in accordance with Section 903.3.1.1.
2. Elevators not required to be located in a shaft in accordance with Section 712.1 are not required to have enclosed elevator lobbies.
3. Enclosed elevator lobbies are not required where additional doors are provided at the hoistway opening in accordance with Section 3002.6. Such doors shall comply with the smoke and draft control door assembly requirements in Section 716.5.3.1 when tested in accordance with UL 1784 without an artificial bottom seal.
4. Enclosed elevator lobbies are not required where the building is protected by an *automatic sprinkler system* installed in accordance with Section 903.3.1.1 or 903.3.1.2. This exception shall not apply to the following:
 - 4.1 Group B buildings providing *medical care* on other than the level of exit discharge.
 - 4.1.2 Group I-2 occupancies;
 - 4.2 3 Group I-3 occupancies;
 - 4.4 Group R-1 occupancies;
 - 4.5 Group R-2 occupancies; and
 - 4.36. Elevators serving floor levels over 75 feet (22 860 mm) above the lowest level of fire department vehicle access in high-rise buildings.
5. Smoke partitions shall be permitted in lieu of fire partitions to separate the elevator lobby at each floor where the building is equipped throughout with an automatic sprinkler system installed in accordance with Section 903.3.1.1 or 903.3.1.2. In addition to the requirements in Section 710 for smoke partitions, doors protecting openings in the smoke partitions shall also comply with Sections 710.5.2.2, 710.5.2.3, and 716.5.9 and duct penetrations of the smoke partitions shall be protected as required for corridors in accordance with Section 717.5.4.1.
6. Enclosed elevator lobbies are not required where the elevator hoistway is pressurized in accordance with Section 909.21.
7. Enclosed elevator lobbies are not required where the elevator serves only open parking garages in accordance with Section 406.5.

Reason: Occupants of Group B *medical care* office buildings commonly have physical impairments that render them more susceptible to the injurious effects of smoke and products of combustion. This population often requires an accessible *means of egress* to access services in building areas and levels and typically require extended time to successfully egress from the upper floors of any building. Occupants within residential occupancy groups R-1 and R-2 are expected to be asleep at various hours of any day, and when awakened by a building fire alarm system, may encounter exit corridors filled with debilitating levels of products of combustion and smoke from an incipient fire on a floor below. These persons may likely be endangered by such products of combustion arising through the unprotected vertical openings provided for unprotected elevator hoistways.

Common sense and years of fire experience have clearly demonstrated the negative impact and deleterious effect of products of combustion to human life. Individuals with compromised cardio-vascular and pulmonary functions, and the elderly, are at higher risk to be incapacitated by inhalation of any products of combustion. With this in mind, it is important that floors and corridors of Occupancy Groups B, R-1, and R-2 be protected from direct and open communication with any unenclosed vertical opening that could provide for the vertical transport of products of combustion within these at-risk occupancies.

Cost Impact: The code change proposal will increase the cost of construction.

FS63-12

Public Hearing:	Committee:	AS	AM	D
	Assembly:	ASF	AMF	DF

713.14.1 #1-FS-KABELE

FS64 – 12

713.14.1

Proponent: Rick Kabele, CBO, CFM, CFPS; Building Safety Associates, LLC, representing the Alliance for Fire and Smoke Containment and Control, Inc. (rick@buildingsafetyassociates.com)

Revise as follows:

713.14.1 Elevator lobby. An enclosed elevator lobby shall be provided at each floor where an elevator shaft enclosure connects more than three *stories*. The lobby enclosure shall separate the elevator shaft enclosure doors from each floor by *fire partitions*. In addition to the requirements in Section 708 for *fire partitions*, doors protecting openings in the elevator lobby enclosure walls shall also comply with Section 716.5.3 as required for *corridor* walls and penetrations of the elevator lobby enclosure by ducts and air transfer openings shall be protected as required for *corridors* in accordance with Section 717.5.4.1. Elevator lobbies shall have at least one *means of egress* complying with Chapter 10 and other provisions within this code.

Exceptions:

1. Enclosed elevator lobbies are not required at the level(s) of *exit discharge*, provided the level(s) of *exit discharge* is equipped with an *automatic sprinkler system* in accordance with Section 903.3.1.1.
2. Elevators not required to be located in a shaft in accordance with Section 712.1 are not required to have enclosed elevator lobbies.
3. Enclosed elevator lobbies are not required where additional doors are provided at the hoistway opening in accordance with Section 3002.6. Such doors shall comply with the smoke and draft control door assembly requirements in Section 716.5.3.1 when tested in accordance with UL 1784 without an artificial bottom seal.
4. Enclosed elevator lobbies are not required where the building is protected by an *automatic sprinkler system* installed in accordance with Section 903.3.1.1 or 903.3.1.2. This exception shall not apply to the following:
 - 4.1. Group I-2 occupancies;
 - 4.2. Group I-3 occupancies; ~~and~~
 - 4.3. Group R-1 and R-2 occupancies more than four stories above the lowest level of fire department vehicle access; and
 - 4.34. Elevators serving floor levels over 75 feet (22 860 mm) above the lowest level of fire department vehicle access in high-rise buildings.
5. Smoke partitions shall be permitted in lieu of *fire partitions* to separate the elevator lobby at each floor where the building is equipped throughout with an *automatic sprinkler system* installed in accordance with Section 903.3.1.1 or 903.3.1.2. In addition to the requirements in Section 710 for smoke partitions, doors protecting openings in the smoke partitions shall also comply with Sections 710.5.2.2, 710.5.2.3, and 716.5.9 and duct penetrations of the smoke partitions shall be protected as required for *corridors* in accordance with Section 717.5.4.1.
6. Enclosed elevator lobbies are not required where the elevator hoistway is pressurized in accordance with Section 909.21.
7. Enclosed elevator lobbies are not required where the elevator serves only *open parking garages* in accordance with Section 406.5.

Reason: The addition of sub-section 4.4, providing exclusions to the exception for occupancy groups R-1 and R-2 is made with the intent to provide a similar level of occupant protection to individuals of these occupancies to those of I-2 healthcare facilities who may be asleep, compromised by recognized disability, or otherwise impaired and unable to exit a building in a timely manner. The previous sub-section 4.3 is re-numbered accordingly.

Cost Impact: The code change proposal will increase the cost of construction, but not greater than that required by the codes prior to the 2012 editions.

FS64-12

Public Hearing:	Committee:	AS	AM	D
	Assembly:	ASF	AMF	DF

713.14.1 #2-FS-KABELE

FS65 – 12

713.14.1

Proponent: John Williams, CBO, Chair, ICC Ad Hoc Committee on Healthcare

Revise as follows:

713.14.1 Elevator lobby. An enclosed elevator lobby shall be provided at each floor where an elevator shaft enclosure connects more than three *stories*. The lobby enclosure shall separate the elevator shaft enclosure doors from each floor by *fire partitions*. In addition to the requirements in Section 708 for *fire partitions*, doors protecting openings in the elevator lobby enclosure walls shall also comply with Section 716.5.3 as required for *corridor* walls and penetrations of the elevator lobby enclosure by ducts and air transfer openings shall be protected as required for *corridors* in accordance with Section 717.5.4.1. Elevator lobbies shall have at least one *means of egress* complying with Chapter 10 and other provisions within this code.

Exceptions:

1. Enclosed elevator lobbies are not required at the level(s) of *exit discharge*, provided the level(s) of *exit discharge* is equipped with an *automatic sprinkler system* in accordance with Section 903.3.1.1.
2. Elevators not required to be located in a shaft in accordance with Section 712.1 are not required to have enclosed elevator lobbies.
3. Enclosed elevator lobbies are not required where additional doors are provided at the hoistway opening in accordance with Section 3002.6. Such doors shall comply with the smoke and draft control door assembly requirements in Section 716.5.3.1 when tested in accordance with UL1784 without an artificial bottom seal.
4. Enclosed elevator lobbies are not required where the building is protected by an automatic sprinkler system installed in accordance with Section 903.3.1.1 or 903.3.1.2. This exception shall not apply to the following:
 - 4.1 ~~Group I-2 occupancies~~
 - 4.12 Group I-3 occupancies; and
 - 4.23 Elevators serving floor levels over 75 feet above the lowest level of fire department vehicle access in high-rise buildings.
5. Smoke partitions shall be permitted in lieu of *fire partitions* to separate the elevator lobby at each floor where the building is equipped throughout with an *automatic sprinkler system* installed in accordance with Section 903.3.1.1 or 903.3.1.2. In addition to the requirements in Section 710 for smoke partitions, doors protecting openings in the smoke partitions shall also comply with Sections 710.5.2.2, 710.5.2.3, and 716.5.9 and duct penetrations of the smoke partitions shall be protected as required for *corridors* in accordance with Section 717.5.4.1.
6. Enclosed elevator lobbies are not required where the elevator hoistway is pressurized in accordance with Section 909.21. 7. Enclosed elevator lobbies are not required where the elevator serves only *open parking garages* in accordance with Section 406.5.

Reason: Previous to the 2009 version, the IBC did not require hospitals, nursing homes and boarding homes to provide elevator lobbies if the building was provided with fire sprinklers. Elevator lobbies serve no purpose on floors of facilities that "defend in place". It is a long standing practice in healthcare to evacuate patients to the adjacent smoke compartment instead of evacuating them out of the building. Group I-2 provides smoke compartmentation for an added level of protection against the spread of smoke through the building. Floors are separated into at least two smoke compartments by rated construction and provide passive protection in addition to the active protection of a sprinkler system. These compartments in effect serve the same purpose as an elevator lobby.

The addition of elevator lobbies in these facilities could complicate the movement of patients to the adjacent smoke compartment by adding doors that bedridden patients must be transferred through. While alternatives to elevator lobbies exist, all increase construction cost for facility type who have a good fire record.

This proposal is submitted by the ICC Ad Hoc Committee on Healthcare (AHC). The AHC was established by the ICC Board of Directors to evaluate and assess contemporary code issues relating to hospitals and ambulatory healthcare facilities. The AHC is composed of building code officials, fire code officials, hospital facility engineers, and state healthcare enforcement representatives. The goals of the committee are to ensure that the ICC family of codes appropriately addresses the fire and life safety concerns of a

highly specialized and rapidly evolving healthcare delivery system. This process is part of a joint effort between ICC and the American Society for Healthcare Engineering (ASHE), a subsidiary of the American Hospital Association, to eliminate duplication and conflicts in healthcare regulation. Since its inception in April, 2011, the AHC has held 5 open meetings and over 80 workgroup calls which included members of the AHC as well as any interested party to discuss and debate the proposed changes. All meeting materials and reports are posted on the AHC website at: <http://www.iccsafe.org/cs/AHC/Pages/default.aspx>.

Cost Impact: None

FS65-12

Public Hearing:	Committee:	AS	AM	D
	Assembly:	ASF	AMF	DF

713.14.1-FS-Williams-Adhoc

FS66 – 12

713.14.1 (New), 713.14.1, 713.14.1.1

Proponent: Carl Baldassarra, P.E., FSFPE, Chair, ICC Code Technology Committee

Add new text as follows:

713.14.1 General. Enclosed elevator lobbies shall be provided in accordance with Section 713.14.2 for hoistways exceeding 420 feet (128 000 mm) in height. The height of the hoistway shall be measured from the top of the lowest finished floor to the top of the highest finished floor of the floors served by the hoistway.

The height of elevator hoistways sharing a common atmosphere by elevator door openings at a common floor or by openings between hoistways shall be measured from the top of the lowest finished floor to the top of the highest finished floor of the floors served by the non separated hoistways.

Exceptions:

1. The height of elevator hoistways sharing a common atmosphere only at a level of exit discharge shall be permitted to be measured separately.
2. The height of elevator hoistways with openings at a common floor shall be permitted to be measured separately where the hoistways are separated by at least 2 sets of doors or a revolving door that maintains a separation of the atmosphere.

713.14.2~~4~~ Elevator lobby requirements. Where an enclosed elevator lobby is required they shall be provided at each floor hoistway entrance where an elevator shaft enclosure connects more than three stories. The lobby enclosure shall separate the elevator shaft enclosure doors from each floor by *fire partitions*. In addition to the requirements in Section 708 for *fire partitions*, doors protecting openings in the elevator lobby enclosure walls shall also comply with Section 716.5.3 as required for *corridor* walls and penetrations of the elevator lobby enclosure by air ducts and transfer openings shall be protected as required for *corridors* in accordance with Section 717.5.4.1. Elevator lobbies shall have at least one *means of egress* complying with Chapter 10 and other provisions within this code.

Exceptions:

1. Enclosed elevator lobbies are not required at the level(s) of *exit discharge*, provided the level(s) of *exit discharge* is equipped with an *automatic sprinkler system* in accordance with Section 903.3.1.1.
2. Elevators not required to be located in a hoistway shaft in accordance with Section 712 are not required to have enclosed elevator lobbies.
3. Enclosed elevator lobbies are not required where additional doors are provided at the hoistway opening in accordance with Section 3002.6. Such doors shall comply with the smoke and draft control door assembly requirements in Section 716.5.3.1 when tested in accordance with UL 1784 without an artificial bottom seal.
4. ~~Enclosed elevator lobbies are not required where the building is protected by an *automatic sprinkler system* installed in accordance with Section 903.3.1.1 or 903.3.1.2. This exception shall not apply to the following:~~
 - 4.1 ~~Group I-2 occupancies;~~
 - 4.2 ~~Group I-3 occupancies, and~~
 - 4.3 ~~Elevators serving floor levels over 75 feet (22 860 mm) above the lowest level of fire department vehicle access in high-rise buildings.~~
54. Smoke partitions shall be permitted in lieu of *fire partitions* to separate the elevator lobby at each floor where the building is equipped throughout with an *automatic sprinkler system* installed in accordance with Section 903.3.1.1 or 903.3.1.2. In addition to the requirements in Section 710 for smoke partitions, doors protecting openings in the smoke partitions shall also

comply with Sections 710.5.2.2, 710.5.2.3, and 716.5.9 and duct penetrations of the smoke partitions shall be protected as required for *corridors* in accordance with Section 717.5.4.1.

65. Enclosed elevator lobbies are not required where the elevator hoistway is pressurized in accordance with Section 909.21.

76. Enclosed elevator lobbies are not required where the elevator serves only *open parking garages* in accordance with Section 406.5.

~~713.14.1.1 Area of refuge. Areas of refuge shall be provided as required by Section 1007.~~

Reason: This proposal is one of several proposals submitted by the CTC Elevator lobby SG. The ICC Executive Board directed the Code Technology Committee (CTC) to study the issue of elevator lobby separations in November 2010 due to the number of code change proposals submitted addressing this issue over a number of code change cycles. The Code Technology Committee formed a study group on the elevator lobby separation issue in December 2010. Note that this subject had been previously addressed by CABO/BCMC in 1986 with a similar conclusion. The code change proposals submitted are the result of the CTC's study of the issue. Note that the scope of the activity was as follows:

Scope

- Review the need for elevator lobbies, with emphasis on building use, building and hoistway height, active and passive fire protection features associated with the aforementioned.
- Review the differences and specific needs when dealing with elevator lobbies of traditional-use elevators, fire service elevators, and occupant evacuation elevators.
- Review related code provisions, such as egress from and through elevator lobbies.
- Review the appropriate use of alternatives including pressurization of hoistways, additional doors, roll-down style barriers, and gasketing systems.
- Review with members of elevator industry to scope the requirements of applicable elevator reference standards as it deals with elevator lobby design, use and construction.
- Review design and construction requirements for elevator lobbies, including but not limited to dimensions, location and separation.
- Review applicable code change history, technical studies and loss statistics as part of this review.

Based upon the extensive nature of this area of study, 5 Task Groups were formed during the process to provide in-depth review and to manage the number of issues. These task groups developed a number of proposals that were coordinated throughout the process.

More information on this CTC area of study can be found at the following link.
<http://www.iccsafe.org/cs/CTC/Pages/ElevatorLobbies.aspx>

This proposal is a technical shift away from what has been termed by the CTC study group "traditional elevator lobbies" as opposed to Fire Service Access Elevators and Occupant evacuation elevators. This shift is based upon background data and a technical analysis produced by the Study Group on Elevator lobbies for the CTC. An executive summary of the technical analysis is as follows:

EXECUTIVE SUMMARY

The ICC Executive Board directed the Code Technology Committee (CTC) to study the issue of elevator lobby separations in November 2010 due to the number of code change proposals submitted addressing this issue over a number of code change cycles. The Code Technology Committee formed a study group on the elevator lobby separation issue in December 2010. The code change proposals submitted are the result of the CTC's study of the issue.

This focus of the study group began with a review of technical documents and the history of the code provisions over the years. This led to extensive discussions on the intent and need for enclosed elevator lobbies and included calculations to determine the effect of stack effect in high rise buildings. This technical review resulted in a technical analysis that determined when enclosed elevator lobbies should be required.

Enclosed elevator lobbies should not be required for:

- Low-rise and mid-rise buildings not provided with sprinkler protection
- High rise buildings where the elevator hoistway is 420 feet or less in height.
Enclosed elevator lobbies should be required for:
- Elevator hoistways exceeding 420 feet in height
- Fire Service Access Elevators regardless of building height
- Occupant evacuation elevators regardless of building height

The basis for eliminating the requirement for enclosed elevator lobby separations in low-rise and mid-rise buildings (whether or not provided with sprinkler protection) is that these buildings can be evacuated in a relatively short period of time. Hence, any hazard of the spread of smoke via the elevator hoistways in these buildings is mitigated by evacuation of the building occupants.

The basis for eliminating the requirement for enclosed elevator lobby separations in high rise buildings (where the height of the elevator hoistway is 420 feet or less) is the many fire safety features required by the building code, including automatic sprinklers, that mitigate the hazard of the spread of smoke via elevator hoistways. The cooling of the smoke by automatic sprinkler discharge also reduces its buoyancy, the principal driving force which causes migration of smoke between floors. The "stack effect", the pressure differentials between floors due to differences in indoor and outdoor temperatures, is not significant enough to cause large quantities of smoke from the floor of origin to migrate to other floors in the building.

The decision to require enclosed elevator lobbies in buildings where the elevator hoistway height exceeds 420 feet in height relates to the greater concern with stack effect in such tall shafts and the potential consequences of fires in taller buildings with larger occupant loads further from the level of exit discharge.

One of the concerns that the CTC wrestled with in developing these proposals is the reliability and effectiveness of a building's many fire safety features but most specifically automatic sprinklers. To further address these concerns the technical analysis presents a brief analysis of the various protection features available in high rise buildings and how they work together. This analysis makes it clear that sprinklers are just one of many fire safety features that are part of a holistic protection strategy in high rise buildings.

Based upon the technical analysis the requirements for enclosed elevator lobbies have been shifted to hoistway heights starting beyond 420 feet. The full recommendations are listed below:

Recommendations:

1. Unsprinklered low- and mid-rise buildings (buildings with an occupied floor less than 55 feet above the lowest level of fire department vehicle access or less than 75 feet above the lowest level of fire department access with an occupant load less than 30 on each floor)

- **No enclosed elevator lobbies required for traditional elevators.**

- *Rationale: While fire temperatures can be high, causing smoke and gas migration throughout the building, occupants traveling at the typical rate of about 150 ft/min over the maximum permitted travel distance of 200 ft can reach the safety of an egress stairway in approximately 1.3 minutes and can descend to the level of exit discharge in less than five minutes. This time frame is merely an approximation but provides an indication of the required time necessary for egress in low and mid-rise buildings.*

Additionally, code officials participating in the study group stated that lobbies have traditionally not been required in these type buildings in their jurisdictions and their experience has been good.

Sprinklers are required in any building containing Fire service access (3007) and occupant evacuation (3008) elevators so these would not be found in buildings in this category.

Elevator lobbies serving as an area of refuge in accordance with Section 1007.6 for accessible means of egress are required to be enclosed by smoke barriers

2. Sprinklered buildings with occupied floors less than or equal to 75 feet to the lowest level of fire department vehicle access:

- **No enclosed elevator lobbies required for traditional elevators**

- *Rationale: In sprinklered buildings fire temperatures are kept relatively low so hot gas expansion and buoyancy are not driving forces. Traditional elevators are not to be used by occupants in fires, so any small infiltration into the hoistway is not significant. Shafts shorter than 75 feet have limited stack effect flows.*

- **Enclosed lobbies required for fire service access (3007) and occupant evacuation (3008) elevators**

- *Rationale: Fire service access and occupant egress elevators need to continue in operation during a fire. Lobbies provide a protected space to stage and to await the elevator and further provide a physical barrier to smoke that might activate a lobby smoke detector and trigger Phase I recall.*

3. Sprinklered buildings with an occupied floor more than 75 feet to the lowest level of fire department vehicle access and with elevator hoistway heights less than or equal to 420 feet.

- **No enclosed elevator lobbies required for traditional elevators.**

- *Rationale: In sprinklered buildings fire temperatures at the ceiling are kept relatively low so hot gas expansion and buoyancy are not driving forces. Traditional elevators are not to be used by occupants in fires, so any small infiltration into the hoistway is not significant. Shafts shorter than 420 feet have limited stack effect flows.*

- **Enclosed elevator lobbies required for fire service access (3007) and occupant evacuation (3008) elevators**

- *Rationale: Fire service access and occupant egress elevators need to continue in operation during a fire. Lobbies provide a protected space to stage and to await the elevator and further provide a physical barrier to smoke that might activate a lobby smoke detector and trigger Phase I recall.*

4. Sprinklered buildings with hoistway heights more than 420 feet in building height

- **Enclosed elevator lobbies or pressurization of the elevator hoistways required for traditional elevators.**

- *Rationale: While traditional elevators are not permitted to be used in fires, the elevator hoistway height may result in smoke migration due to "stack effect" and spread to remote areas. Enclosed lobbies with smoke tight construction or pressurization of the hoistways will limit infiltration. The consequences of smoke spread in tall buildings with elevator hoistway heights over 420 feet was of greater concern to the Study Group.*

- **EXCEPTION:**

1. **Hoistways for traditional elevators separated into vertical sections not exceeding 420 feet in height with no communication of the hoistway environment between sections shall not require enclosed lobbies or pressurization as long as the following condition is met.**

2. **Where connection of elevator banks is by a transfer corridor, it shall be necessary to pass through at least 2 swinging doors or a revolving door that maintains a separation of the environments to pass from one section to another.**

- *Rationale: By separating the hoistways into shorter sections and limiting communication of different shaft environments, both "stack effect" and smoke migration will be limited.*

- **Enclosed elevator lobbies required for fire service access (3007) and occupant evacuation (3008) elevators**

- *Rationale: Fire service access and occupant egress elevators need to continue in operation during a fire. Lobbies provide a protected space to stage and to await the elevator and further provide a physical barrier to smoke that might activate a lobby smoke detector and trigger Phase I recall.*

5. Elevator hoistway pressurization design

- **The design of pressurization systems for elevator hoistways shall be based on a *rational analysis* in accordance with Section 909.4 that utilizes a network model approved by the AHJ and which includes an analysis of possible interactions between building shafts pressurized by different systems, and between pressurized and unpressurized shafts that exceed 420 feet in height.**

Add guidance to commentary for 909.4 that the rational analysis should show that the pressurization design will maintain the estimated Fractional Effective Dose (FED) below 0.5 and the estimated visibility distance above 25 feet within the stairway for 1.5 times the estimated evacuation time for each of the design fires selected.

- *Rationale: Taller buildings with more complex flow paths require analysis utilizing a network model that can account for these interacting flow paths. The criteria suggested for commentary represents the standard of practice for a fire hazard analysis performed as the required rational analysis.*

It is important to note that these recommendations address fire service access elevators as well as occupant evacuation elevators but such elevators are not applicable to Section 713.14. In fact the recommendation of the analysis for those types of elevators was to keep the lobbies as they provide a multitude of functions that differ from traditional elevator lobbies. Additionally it should be noted that although enclosed elevator lobbies have been eliminated in many buildings for "traditional" elevators any building containing occupied floors more than 120 feet from the lowest level of fire department access will be required to have fire service access elevators. Such elevators are required to have a lobby with several integral features. If the elevators of choice are passenger elevators in the building an enclosed elevator lobby would be required of more substantial construction as compared to what is required in Section 713.14.1. This same logic would apply in buildings that allow the use of elevators for evacuation in accordance with Section 3008. In that case lobbies would be required for the entire building regardless of building height.

Since the buildings where elevator lobbies are required by this proposal will be sprinklered and area of refuge would not be required the reference to area of refuge as it relates to elevator lobbies is no longer necessary.

If this proposal passes the other CTC proposals related to elevator lobbies may require some level of renumbering or will no longer be necessary. As this is one of several proposals from the CTC on elevator lobbies a draft assuming all the CTC elevator lobby related proposals passing is provided to show how they would integrate together. Each proposal in intent are independent with one another. There are some situations that may need approval of the CCC but the following demonstrates the intent of the CTC should all proposals pass.

Chapter 2

(G175-12) DIRECT ACCESS. A path of travel from a space to an immediately adjacent space through an opening in the common wall between the two spaces.

Chapter 7

(FS37-12) 709.4 Continuity. *Smoke barriers* shall form an effective membrane continuous from outside wall to outside wall and from the top of the foundation or floor/ceiling assembly below to the underside of the floor or roof sheathing, deck or slab above, including continuity through concealed spaces, such as those found above suspended ceilings, and interstitial structural and mechanical spaces. The supporting construction shall be protected to afford the required *fire-resistance rating* of the wall or floor supported in buildings of other than Type IIB, IIIB or VB construction.

Exceptions:

1. Smoke-barrier walls are not required in interstitial spaces where such spaces are designed and constructed with ceilings that provide resistance to the passage of fire and smoke equivalent to that provided by the smoke-barrier walls.
2. Smoke barriers used for to enclose elevator lobbies in accordance with Section 405.4.3, 1007.6.2, 30078.7.2 or 30089.7.2 shall be permitted to terminate at the elevator hoistway shaft enclosure, not required to extend from outside wall to outside wall. A smoke and draft control door assembly as specified in Section 716.5.3.1 shall not be required at each elevator hoistway door opening.
3. Smoke barriers used for areas of refuge in accordance with Section 1007.6.2 are not required to extend from outside wall to outside wall.

(FS88-12) 716.5.3.1 Smoke and draft control. *Fire door* assemblies shall also meet the requirements for a smoke and draft control door assembly tested in accordance with UL 1784. The air leakage rate of the door assembly shall not exceed 3.0 cubic feet per minute per square foot (0.01524 m³/s · m²) of door opening at 0.10 inch (24.9 Pa) of water for both the ambient temperature and elevated temperature tests. Louvers shall be prohibited. Installation of smoke doors shall be in accordance with NFPA 105.

Exception: Where enclosed elevator lobbies are not required by Section 3007.2 713.14.1, elevator hoistway doors opening into a corridor are not required to meet the requirements for a smoke and draft control door assembly.

Chapter 10

(E45-12) 1007.6 Areas of refuge. Every required area of refuge shall be accessible from the space it serves by an accessible means of egress.

1007.6.1 Travel distance. The maximum travel distance from any accessible space to an area of refuge shall not exceed the travel distance permitted for the occupancy in accordance with Section 1016.1.

1007.6.2 Stairway or elevator access. Every required area of refuge shall have direct access to a stairway within an exit enclosure complying with Sections 1007.3 and 1022 or an elevator complying with Section 1007.4. ~~Where an elevator lobby is used as an area of refuge, the shaft and lobby shall comply with Section 1022.9 for smokeproof enclosures except where the elevators are in an area of refuge formed by a horizontal exit or smoke barrier.~~

1007.6.23 Separation. Each *area of refuge* shall be separated from the remainder of the story by a *smoke barrier* complying with Section 709 or a *horizontal exit* complying with Section 1025. Each *area of refuge* shall be designed to minimize the intrusion of smoke.

Exception: Areas of refuge located within an enclosure for exit access stairways or interior exit stairways complying with Section 1009.3 or Section 1022.

1007.6.35 Two-way communication. *Areas of refuge* shall be provided with a two-way communication system complying with Sections 1007.8.1 and 1007.8.2.

(E110-12) Add a new item 5 to section 1014.2:

5. Exit access through an enclosed elevator lobby is permitted. Access to at least one of the required exits shall be provided without travel through the enclosed elevator lobbies required by Sections 3007.2 713.14.1, 30078 or 30089.

Where the path of exit access travel passes through an enclosed elevator lobby the level of protection required for the enclosed elevator lobby is not required to be extended to the exit unless direct access to an exit is required by other sections of this code.

(E110-12) 1018.6 Corridor continuity. Fire-resistance-rated *corridors* shall be continuous from the point of entry to an *exit*, and shall not be interrupted by intervening rooms. Where the path of egress travel within a fire-resistance-rated *corridor* to the *exit* includes travel along unenclosed *exit access stairways* or *ramps*, the *fire resistance-rating* shall be continuous for the length of the *stairway* or *ramp* and for the length of the connecting *corridor* on the adjacent floor leading to the *exit*.

Exceptions:

1. Foyers, lobbies or reception rooms constructed as required for *corridors* shall not be construed as intervening rooms.
2. Enclosed elevator lobbies as permitted by Section 1014.2 item 5 shall not be construed as intervening rooms.

(E144-12) 1022.10 Elevator Lobby identification signs. At landings in interior exit stairways where two or more doors lead to the floor level, the door leading to the elevator lobby shall be identified by signage located on the door or directly adjacent to the door stating "Elevator Lobby." Signage shall be in accordance with Section 1022.9.1 items 4, 5 and 6.

(G125-12) 1027.1 General. Exits shall discharge directly to the exterior of the building. The exit discharge shall be at grade or shall provide a direct path of egress travel access to grade. The exit discharge shall not reenter a building. The combined use of Exceptions 1 and 2 shall not exceed 50 percent of the number and capacity of the required exits.

Chapter 30

(FS61-12, FS66-12, FS67-12, FS70-12, E110-12,)

SECTION 3007

ELEVATOR LOBBIES

3007.1 General. Enclosed elevator lobbies shall be provided in accordance with the following sections.

1. Section 3007.2 based upon hoistway height number of stories connected by a shaft enclosure. (CCC)
2. Section 405.4.3 for underground buildings.
3. Sections 407.5.3 and 711.9 for Group I-2 occupancies.
4. Section 4007.4 for areas of refuge. (CCC)
4. Section 3008.7.2 for fire service access elevators.
5. Section 3009.7.2 for occupant evacuation elevators.

3007.2-713-14.1 General. Protection of hoistway door openings Enclosed elevator lobbies (CCC) shall be provided in accordance with Section 3007.3 713-14.2 for hoistways exceeding 420 feet (128 000 mm) in height. The height of the hoistway shall be measured from the top of the lowest finished floor to the top of the highest finished floor of the floors served by the hoistway.

The height of elevator hoistways sharing a common atmosphere by elevator door openings at a common floor or by openings between hoistways shall be measured from the top of the lowest finished floor to the top of the highest finished floor of the floors served by the non separated hoistways.

Exceptions:

1. The height of elevator hoistways sharing a common atmosphere only at a level of exit discharge shall be permitted to be measured separately.
2. The height of elevator hoistways with openings at a common floor shall be permitted to be measured separately where the hoistways are separated by at least 2 sets of doors or a revolving door that maintains a separation of the atmosphere.
3. Protection of elevator hoistway door openings is not required where the elevator serves only open parking garages in accordance with Section 406.5.
4. Protection of elevator hoistway door openings is not required at the level(s) of exit discharge, provided the level(s) of exit discharge is equipped with an automatic sprinkler system in accordance with Section 903.3.1.1.
5. Elevators not required to be located in a shaft in accordance with Section 712.1 are not required to protect elevator hoistway door openings. (this is something that needs to be stated here but not in the original TG4 proposal 2 CCC)
6. Enclosed elevator lobbies and protection of elevator hoistway door openings are not required where the elevator hoistway opens to the exterior.

3007.3-713-14.2 Elevator hoistway door opening protection Lobby requirements. Where Section 3007.2-713-14.4 requires protection of the elevator hoistway door opening, one of the following protection options shall be provided. Where an enclosed elevator lobby is required they shall be provided at each floor hoistway entrance where an elevator shaft enclosure connects more than three stories.

1. The A lobby enclosure shall separate the elevator shaft enclosure doors from each floor by fire partitions. In addition to the requirements in Section 708 for fire partitions, doors protecting openings in the elevator lobby enclosure walls shall also comply with Section 716.5.3 as required for corridor walls and penetrations of the elevator lobby enclosure by air ducts and transfer openings shall be protected as required for corridors in accordance with Section 717.5.4.1. Elevator lobbies shall have at least one means of egress complying with Chapter 10 and other provisions within this code.

Exceptions:

1. Enclosed elevator lobbies are not required at the level(s) of exit discharge, provided the level(s) of exit discharge is equipped with an automatic sprinkler system in accordance with Section 903.3.1.1.
2. Elevators not required to be located in a hoistway shaft in accordance with Section 712 are not required to have enclosed elevator lobbies.
2. An enclosed elevator lobby shall be provided at each floor to separate the elevator hoistway shaft enclosure doors from each floor by smoke partitions in accordance with Section 710 where the building is equipped throughout with an automatic sprinkler system installed in accordance with 903.3.1.1 or 903.3.1.2. In addition, doors protecting openings in the smoke partitions shall comply with Sections 710.5.2.2, 710.5.2.3, and 716.5.9. Penetrations of the enclosed elevator lobby by ducts and air transfer openings shall be protected as required for corridors in accordance with Section 717.5.4.1.

3. Enclosed elevator lobbies are not required where An additional doors shall be are provided at the each elevator hoistway door opening in accordance with Section 3002.6. Such door shall comply with the smoke and draft control door assembly requirements in Section 716.5.3.1 when tested in accordance with UL 1784 without an artificial bottom seal.
4. Enclosed elevator lobbies are not required where the building is protected by an automatic sprinkler system installed in accordance with Section 903.3.1.1 or 903.3.1.2. This exception shall not apply to the following:
 - 4.1 Group I-2 occupancies;
 - 4.2 Group I-3 occupancies; and
 - 4.3 Elevators serving floor levels over 75 feet (22 860 mm) above the lowest level of fire department vehicle access in high-rise buildings.
5. Smoke partitions shall be permitted in lieu of fire partitions to separate the elevator lobby at each floor where the building is equipped throughout with an automatic sprinkler system installed in accordance with Section 903.3.1.1 or 903.3.1.2. In addition to the requirements in Section 710 for smoke partitions, doors protecting openings in the smoke partitions shall also comply with Sections 710.5.2.2, 710.5.2.3, and 716.5.9 and duct penetrations of the smoke partitions shall be protected as required for corridors in accordance with Section 717.5.4.1.
- 4.6. Enclosed Elevator lobbies are not required where the The elevator hoistway is shall be pressurized in accordance with Section 909.21.
7. Enclosed elevator lobbies are not required where the elevator serves only open parking garages in accordance with Section 406.5.

3007.4-713.14.3 Means of egress. Enclosed (CCC based on definition) Elevator lobbies shall be provided with at least one means of egress complying with Chapter 10 and other provisions in this code. Egress through an elevator lobby shall be permitted in accordance with Section 1014.2 item 5

713.14.1.1 Area of refuge. Areas of refuge shall be provided as required by Section 1007.

(note 3007 and 3008 would need to be renumbered in entirety)

(E110-12) 3007.7 Fire service access elevator lobby. The fire service access elevator shall open into a fire service access elevator lobby in accordance with Sections 3007.7.1 through 3007.7.5. Egress is permitted through the elevator lobby in accordance with Section 1014.2 item 5.

Exception: Where a fire service access elevator has two entrances onto a floor, the second entrance shall be permitted to open into an elevator lobby in accordance with Section 708.14.1.

(G175-12) 3007.7.1 Interior exit stairway access. The fire service access elevator lobby shall have direct access from the enclosed elevator lobby to an enclosure for an interior exit stairway.

Exception: Access to an interior exit stairway shall be permitted to be through a protected path of travel that has a level of fire protection not less than the elevator lobby enclosure. The protected path shall be separated from the enclosed elevator lobby through an opening protected by a smoke and draft control assembly in accordance Section 716.5.3.

(G177-12) 3007.7.4 Lobby size. Regardless of the number of fire service access elevators served by the same elevator lobby, each the enclosed fire service access elevator lobby shall be a minimum of 150 square feet (14 m²) in an area with a minimum dimension of 8 feet (2440 mm).

(E110-12) 3008.7 Occupant evacuation elevator lobby. The occupant evacuation elevators shall open into an elevator lobby in accordance with Sections 3008.7.1 through 3008.7.7. Egress is permitted through the elevator lobby in accordance with Section 1014.2 item 5.

(G175-12) 3008.7.1 Interior exit stairway access. The occupant evacuation elevator lobby shall have direct access from the enclosed elevator lobby to an interior exit stairway or ramp.

Exception: Access to an interior exit stairway shall be permitted to be through a protected path of travel that has a level of fire protection not less than the elevator lobby enclosure. The protected path shall be separated from the enclosed elevator lobby through an opening protected by a smoke and draft control assembly in accordance Section 716.5.3.

(Note if all proposals pass the following proposals are no longer necessary FS71-12 and FS69-12)

Cost Impact: This code change proposal will not increase the cost of construction.

FS66-12

Public Hearing:	Committee:	AS	AM	D
	Assembly:	ASF	AMF	DF

713.14.1 #1-FS-Baldassarra-CTC

FS67 – 12

713.14.1, 713.14.1.1, 713.14.3 (New)

Proponent: Carl Baldassarra, P.E., FSFPE, Chair, ICC Code Technology Committee

Revise as follows:

713.14 Elevator, dumbwaiter and other hoistways. Elevator, dumbwaiter and other hoistway enclosures shall be constructed in accordance with Section 713 and Chapter 30.

713.14.1 Elevator hoistway door opening protection required. Elevator hoistway door openings shall be protected in accordance with Section 713.14.2 where an elevator hoistway connects more than three stories, is required to be enclosed within a shaft enclosure in accordance with Section 712.1.1 and where any of the following conditions apply.

1. The building is not protected throughout with an automatic sprinkler system in accordance with Section 903.3.1.1 or 903.3.1.2
2. The building contains a Group I-2 occupancy;
3. The building contains a Group I-3 occupancy;
4. The building is a high rise building and the elevator serves floor levels over 75 feet above the lowest level of fire department vehicle access.

Exceptions:

1. Protection of elevator hoistway door openings is not required where the elevator serves only open parking garages in accordance with Section 406.5.
2. Protection of elevator hoistway door openings is not required at the level(s) of exit discharge, provided the level(s) of exit discharge is equipped with an automatic sprinkler system in accordance with Section 903.3.1.1.

713.14.4 713.14.2 Elevator hoistway door opening protection options Lobby. Where Section 713.14.1 requires protection of the elevator hoistway door opening, one of the following protection options shall be provided.

1. An enclosed elevator lobby shall be provided at each floor where an elevator shaft enclosure connects more than three stories. The shall to separate the elevator hoistway shaft enclosure doors from each floor by fire partitions in accordance with Section 708. In addition, to the requirements in Section 708 for fire partitions, doors protecting openings in the elevator lobby enclosure walls shall also comply with Section 716.5.3 as required for corridor walls, and Penetrations of the enclosed elevator lobby enclosure by ducts and air transfer openings shall be protected as required for corridors in accordance with Section 717.5.4.1. Elevator lobbies shall have at least one means of egress complying with Chapter 10 and other provisions within this code.

Exceptions:

1. Enclosed elevator lobbies are not required at the level(s) of exit discharge, provided the level(s) of exit discharge is equipped with an automatic sprinkler system in accordance with Section 903.3.1.1.
2. Elevators not required to be located in a shaft in accordance with Section 712.1 are not required to have enclosed elevator lobbies.
2. An enclosed elevator lobby shall be provided at each floor to separate the elevator hoistway shaft enclosure doors from each floor by smoke partitions in accordance with Section 710 where the building is equipped throughout with an automatic sprinkler system installed in accordance

with 903.3.1.1 or 903.3.1.2. In addition, doors protecting openings in the smoke partitions shall comply with Sections 710.5.2.2, 710.5.2.3, and 716.5.9. Penetrations of the enclosed elevator lobby by ducts and air transfer openings shall be protected as required for corridors in accordance with Section 717.5.4.1.

3. ~~Enclosed elevator lobbies are not required where~~ An additional doors shall be ~~are~~ provided at the each elevator hoistway door opening in accordance with Section 3002.6. Such door shall comply with the smoke and draft control door assembly requirements in Section 716.5.3.1 when tested in accordance with UL 1784 without an artificial bottom seal.
4. ~~Enclosed elevator lobbies are not required where the building is protected by an automatic sprinkler system installed in accordance with Section 903.3.1.1 or 903.3.1.2. This exception shall not apply to the following:~~
 - 4.1. ~~Group I-2 occupancies;~~
 - 4.2. ~~Group I-3 occupancies; and~~
 - 4.3. ~~Elevators serving floor levels over 75 feet above the lowest level of fire department vehicle access in high-rise buildings.~~
5. ~~Smoke partitions shall be permitted in lieu of fire partitions to separate the elevator lobby at each floor where the building is equipped throughout with an automatic sprinkler system installed in accordance with Section 903.3.1.1 or 903.3.1.2.~~

~~In addition to the requirements in Section 710 for smoke partitions, doors protecting openings in the smoke partitions shall also comply with Sections 710.5.2.2, 710.5.2.3, and 716.5.9 and duct penetrations of the smoke partitions shall be protected as required for corridors in accordance with Section 717.5.4.1.~~

- 4.6 ~~Enclosed Elevator lobbies are not required where the~~ The elevator hoistway is ~~shall be~~ pressurized in accordance with Section 909.21.
7. ~~Enclosed elevator lobbies are not required where the elevator serves only open parking garages in accordance with Section 406.5.~~

713.14.3 Means of egress. Elevator lobbies shall be provided with at least one means of egress complying with Chapter 10 and other provisions in this code.

713.14.1.1 713.14.4 Areas of refuge. Areas of refuge shall be provided as where required in Section 1007.

Reason: This proposal is one of several proposals submitted by the CTC Elevator lobby SG. The ICC Executive Board directed the Code Technology Committee (CTC) to study the issue of elevator lobby separations in November 2010 due to the number of code change proposals submitted addressing this issue over a number of code change cycles. The Code Technology Committee formed a study group on the elevator lobby separation issue in December 2010. Note that this subject had been previously addressed by CABO/BCMC in 1986 with a similar conclusion. The code change proposals submitted are the result of the CTC's study of the issue. Note that the scope of the activity was as follows:

Scope

- Review the need for elevator lobbies, with emphasis on building use, building and hoistway height, active and passive fire protection features associated with the aforementioned.
- Review the differences and specific needs when dealing with elevator lobbies of traditional-use elevators, fire service elevators, and occupant evacuation elevators.
- Review related code provisions, such as egress from and through elevator lobbies.
- Review the appropriate use of alternatives including pressurization of hoistways, additional doors, roll-down style barriers, and gasketing systems.
- Review with members of elevator industry to scope the requirements of applicable elevator reference standards as it deals with elevator lobby design, use and construction.
- Review design and construction requirements for elevator lobbies, including but not limited to dimensions, location and separation.
- Review applicable code change history, technical studies and loss statistics as part of this review.

Based upon the extensive nature of this area of study, 5 Task Groups were formed during the process to provide in-depth review and to manage the number of issues. These task groups developed a number of proposals that were coordinated throughout the process.

More information on this CTC area of study can be found at the following link.
<http://www.iccsafe.org/cs/CTC/Pages/ElevatorLobbies.aspx>

The purpose of this code change is editorial in nature and seeks only to convert the enclosed elevator lobby section to one focused on making the current exceptions equal in stature in the code to the main requirement for a lobby. This also removes some of the confusion with having requirements within some of the exceptions. This proposal focuses on the protection of the elevator opening into the hoistway enclosure versus requiring an enclosed elevator lobby. This allows the other exceptions to become more clear and equal design options.

This proposal may require correlation with other CTC Elevator Lobby SG proposals but more in terms of renumbering. Also if FS##-12 (*TG2 Proposal 1*) passes then Item 4 of new Section 713.14.1 is no longer required. See discussion on CTC elevator lobby proposal coordination in code change FS##-12

Cost Impact: This code change proposal will not increase the cost of construction.

FS67-12

Public Hearing:	Committee:	AS	AM	D
	Assembly:	ASF	AMF	DF

713.14.1 #4-FS-Baldassarra-CTC

FS68 – 12

713.14.1

Proponent: Carl Baldassarra, P.E., FSFPE, Chair, ICC Code Technology Committee

Revise as follows:

713.14.1 Elevator lobby. An enclosed elevator lobby shall be provided at each floor where an elevator shaft enclosure connects more than three stories. The lobby enclosure shall separate the elevator shaft enclosure doors from each floor by fire partitions. In addition to the requirements in Section 708 for fire partitions, doors protecting openings in the elevator lobby enclosure walls shall also comply with Section 716.5.3 as required for corridor walls and penetrations of the elevator lobby enclosure by ducts and air transfer openings shall be protected as required for corridors in accordance with Section 717.5.4.1. Elevator lobbies shall have at least one means of egress complying with Chapter 10 and other provisions within this code.

Exceptions:

1. Enclosed elevator lobbies are not required at the level(s) of exit discharge, provided the level(s) of exit discharge is equipped with an automatic sprinkler system in accordance with Section 903.3.1.1.
2. Elevators not required to be located in a shaft in accordance with Section 712.1 are not required to have enclosed elevator lobbies.
3. Enclosed elevator lobbies are not required where additional doors are provided at the hoistway opening in accordance with Section 3002.6. Such doors shall comply with the smoke and draft control door assembly requirements in Section 716.5.3.1 when tested in accordance with UL 1784 without an artificial bottom seal.
4. Enclosed elevator lobbies are not required where the building is protected by an automatic sprinkler system installed in accordance with Section 903.3.1.1 or 903.3.1.2. This exception shall not apply to the following:
 - 4.1 Group I-1, Condition 2 occupancies;
 - 4.2 Group I-2 occupancies;
 - 4.3 ~~4.2~~ Group I-3 occupancies; and
 - 4.4 ~~4.3~~ Elevators serving floor levels over 75 feet above the lowest level of fire department vehicle access in high-rise buildings.
5. Smoke partitions shall be permitted in lieu of fire partitions to separate the elevator lobby at each floor where the building is equipped throughout with an automatic sprinkler system installed in accordance with Section 903.3.1.1 or 903.3.1.2. In addition to the requirements in Section 710 for smoke partitions, doors protecting openings in the smoke partitions shall also comply with Sections 710.5.2.2, 710.5.2.3, and 716.5.9 and duct penetrations of the smoke partitions shall be protected as required for corridors in accordance with Section 717.5.4.1.
6. Enclosed elevator lobbies are not required where the elevator hoistway is pressurized in accordance with Section 909.21.
7. Enclosed elevator lobbies are not required where the elevator serves only open parking garages in accordance with Section 406.5.

Reason: The CTC Care facilities committee is aware of proposals from the CTC Elevator study group and the Adhoc Healthcare committee that will affect elevator lobby requirements. Currently elevator lobbies are required in Group I-2 and I-3 where smoke compartments are part of the emergency evacuation plan. The CTC Care facilities study group has asked for smoke compartments in Group I-1, Condition 2 as part of a plan to allow for staged evacuation for persons who may require limited assistance in evacuation. If the decision of the membership is that elevator lobby protection is needed in smoke compartment, they should also be required in Group I-1, Condition 2.

The ICC Board established the ICC Code Technology Committee (CTC) as the venue to discuss contemporary code issues in a committee setting which provides the necessary time and flexibility to allow for full participation and input by any interested party. The code issues are assigned to the CTC by the ICC Board as "areas of study". Information on the CTC, including: meeting agendas; minutes; reports; resource documents; presentations; and all other materials developed in conjunction with the CTC effort

can be downloaded from the following website: <http://www.iccsafe.org/cs/cc/ctc/index.html>. Since its inception in April, 2005, the CTC has held twenty-two meetings – all open to the public.

Cost Impact: The code change proposal will increase the cost of construction.

FS68-12

Public Hearing:	Committee:	AS	AM	D
	Assembly:	ASF	AMF	DF

713.14.1-FS-BALDASSARRA-CTC

FS69 – 12

713.14.1

Proponent: Carl Baldassarra, P.E., FSFPE, Chair, ICC Code Technology Committee

Revise as follows:

713.14.1 Elevator lobby. An enclosed elevator lobby shall be provided at each floor where an elevator shaft enclosure connects more than three stories. The lobby enclosure shall separate the elevator shaft enclosure doors from each floor by fire partitions. In addition to the requirements in Section 708 for fire partitions, doors protecting openings in the elevator lobby enclosure walls shall also comply with Section 716.5.3 as required for corridor walls and penetrations of the elevator lobby enclosure by ducts and air transfer openings shall be protected as required for corridors in accordance with Section 717.5.4.1. Elevator lobbies shall have at least one means of egress complying with Chapter 10 and other provisions within this code.

Exceptions:

1. Enclosed elevator lobbies are not required at the level(s) of exit discharge, provided the level(s) of exit discharge is equipped with an automatic sprinkler system in accordance with Section 903.3.1.1.
2. Elevators not required to be located in a shaft in accordance with Section 712.1 are not required to have enclosed elevator lobbies.
3. Enclosed elevator lobbies are not required where additional doors are provided at the hoistway opening in accordance with Section 3002.6. Such doors shall comply with the smoke and draft control door assembly requirements in Section 716.5.3.1 when tested in accordance with UL 1784 without an artificial bottom seal.
4. Enclosed elevator lobbies are not required where the building is protected by an *automatic sprinkler system* installed in accordance with Section 903.3.1.1 or 903.3.1.2. This exception shall not apply to the following:
 - 4.1. Group I-2 occupancies;
 - 4.2. Group I-3 occupancies; and
 - 4.3. Highrise buildings with Elevators hoistways travelling more than serving floor levels over 75 feet in height, above the lowest level of fire department vehicle access in high-rise buildings. The height of the hoistway shall be measured from the lowest floor to the highest floor of the floors served by the hoistway.
5. Smoke partitions shall be permitted in lieu of fire partitions to separate the elevator lobby at each floor where the building is equipped throughout with an automatic sprinkler system installed in accordance with Section 903.3.1.1 or 903.3.1.2. In addition to the requirements in Section 710 for smoke partitions, doors protecting openings in the smoke partitions shall also comply with Sections 710.5.2.2, 710.5.2.3, and 716.5.9 and duct penetrations of the smoke partitions shall be protected as required for corridors in accordance with Section 717.5.4.1.
6. Enclosed elevator lobbies are not required where the elevator hoistway is pressurized in accordance with Section 909.21.
7. Enclosed elevator lobbies are not required where the elevator serves only open parking garages in accordance with Section 406.5.

Reason: This proposal is part of a series of proposals from the CTC addressing elevator lobbies. The ICC Executive Board directed the Code Technology Committee (CTC) to study the issue of elevator lobby separations in November 2010 due to the number of code change proposals submitted addressing this issue over a number of code change cycles. The Code Technology Committee formed a study group on the elevator lobby separation issue in December 2010. Note that this subject had been previously addressed by CABO/BCMC in 1986 with a similar conclusion. The code change proposals submitted are the result of the CTC's study of the issue. Note that the scope of the activity was as follows:

Scope

- Review the need for elevator lobbies, with emphasis on building use, building and hoistway height, active and passive fire protection features associated with the aforementioned.
- Review the differences and specific needs when dealing with elevator lobbies of traditional-use elevators, fire service elevators, and occupant evacuation elevators.
- Review related code provisions, such as egress from and through elevator lobbies.
- Review the appropriate use of alternatives including pressurization of hoistways, additional doors, roll-down style barriers, and gasketing systems.
- Review with members of elevator industry to scope the requirements of applicable elevator reference standards as it deals with elevator lobby design, use and construction.
- Review design and construction requirements for elevator lobbies, including but not limited to dimensions, location and separation.
- Review applicable code change history, technical studies and loss statistics as part of this review.

Based upon the extensive nature of this area of study, 5 Task Groups were formed during the process to provide in-depth review and to manage the number of issues. These task groups developed a number of proposals that were coordinated throughout the process.

More information on this CTC area of study can be found at the following link.

<http://www.iccsafe.org/cs/CTC/Pages/ElevatorLobbies.aspx>

In particular this proposal comes from the Task Group addressing the design and construction of elevator lobbies when they are required by the code.

The wording was revised to clarify that the hazard is related to taller hoistway heights versus an elevator located higher up in the high rise building. In other words a single tenant dedicated elevator that travels only a couple stories should not require an enclosed elevator lobby.

The intent of this proposal is that if item 4.3 of the 2012 remains in the code then the change shall be made but if item 4 and item 4.3 are deleted by other proposals whether from the CTC or other proponents then the revision is no longer necessary. See discussion on CTC elevator lobby proposal coordination in code change FS##-12

Cost Impact: This code change proposal will not increase the cost of construction.

FS69-12

Public Hearing:	Committee:	AS	AM	D
	Assembly:	ASF	AMF	DF

713.14.1 #6-FS-BALDASSARRA-CTC

FS70 – 12

713.14.1

Proponent: Carl Baldassarra, P.E., FSFPE, Chair, ICC Code Technology Committee

Revise as follows:

713.14.1 Elevator lobby. An enclosed elevator lobby shall be provided at each floor where an elevator shaft enclosure connects more than three stories. The lobby enclosure shall separate the elevator shaft enclosure doors from each floor by fire partitions. In addition to the requirements in Section 708 for fire partitions, doors protecting openings in the elevator lobby enclosure walls shall also comply with Section 716.5.3 as required for corridor walls and penetrations of the elevator lobby enclosure by ducts and air transfer openings shall be protected as required for corridors in accordance with Section 717.5.4.1. Elevator lobbies shall have at least one means of egress complying with Chapter 10 and other provisions within this code.

Exceptions:

(No changes to Exceptions 1 through 7)

8. Enclosed elevator lobbies and protection of elevator hoistway door openings are not required where the elevator hoistway opens to the exterior.

Reason: This proposal is part of a series of proposals from the CTC Elevator Lobby Study Group. The ICC Executive Board directed the Code Technology Committee (CTC) to study the issue of elevator lobby separations in November 2010 due to the number of code change proposals submitted addressing this issue over a number of code change cycles. The Code Technology Committee formed a study group on the elevator lobby separation issue in December 2010. Note that this subject had been previously addressed by CABO/BCMC in 1986 with a similar conclusion. The code change proposals submitted are the result of the CTC's study of the issue. Note that the scope of the activity was as follows:

Scope

- Review the need for elevator lobbies, with emphasis on building use, building and hoistway height, active and passive fire protection features associated with the aforementioned.
- Review the differences and specific needs when dealing with elevator lobbies of traditional-use elevators, fire service elevators, and occupant evacuation elevators.
- Review related code provisions, such as egress from and through elevator lobbies.
- Review the appropriate use of alternatives including pressurization of hoistways, additional doors, roll-down style barriers, and gasketing systems.
- Review with members of elevator industry to scope the requirements of applicable elevator reference standards as it deals with elevator lobby design, use and construction.
- Review design and construction requirements for elevator lobbies, including but not limited to dimensions, location and separation.
- Review applicable code change history, technical studies and loss statistics as part of this review.

Based upon the extensive nature of this area of study, 5 Task Groups were formed during the process to provide in-depth review and to manage the number of issues. These task groups developed a number of proposals that were coordinated throughout the process.

More information on this CTC area of study can be found at the following link.
<http://www.iccsafe.org/cs/CTC/Pages/ElevatorLobbies.aspx>

There should be an exception similar to open parking since there is no accumulation of smoke where elevator hoist ways open to the exterior.

This proposal should not be affected by other proposals submitted by the CTC addressing elevator lobbies except for the need to renumber. None of the proposals from the CTC are intending to delete similar exceptions and thus this will simply be added as one of those exceptions. See discussion on CTC elevator lobby proposal coordination in code change FS##-12

Cost Impact: This code change proposal will not increase the cost of construction.

FS70-12

Public Hearing:	Committee:	AS	AM	D
	Assembly:	ASF	AMF	DF

713.14.1 #5-FS-Baldassarra-CTC

FS71 – 12

713.14.1.1, 713.14.1.2 (New), 713.14.1.3 (New), 713.14.1.4 (New), 713.14.1.5 (New)

Proponent: Carl Baldassarra, P.E., FSFPE, Chair, ICC Code Technology Committee

Revise as follows:

713.14.1.1 Areas of refuge. Where an area of refuge is required and an enclosed elevator lobby is provided to serve as an areas of refuge, the enclosed elevator lobby shall comply with as required in Section 1007.6.

713.14.1.2 Fire Service Access Elevators. Where fire service access elevators are provided, enclosed elevator lobbies shall comply with Section 3007.

713.14.1.3 Occupant Evacuation Elevators. Where occupant evacuation elevators are provided, enclosed elevator lobbies shall comply with Section 3008.

713.14.1.4 Underground buildings. Where enclosed elevator lobbies are required for underground buildings such lobbies shall comply with Section 405.4.3.

713.14.1.5 Group I-2 occupancies. Enclosed elevator lobbies required in Group I-2 Occupancies in accordance with Sections 407.5.3 and 711.9 shall comply with Section 713.14.1.

Reason. This proposal is part of a series of proposals from the CTC dealing with Elevator Lobbies. The ICC Executive Board directed the Code Technology Committee (CTC) to study the issue of elevator lobby separations in November 2010 due to the number of code change proposals submitted addressing this issue over a number of code change cycles. The Code Technology Committee formed a study group on the elevator lobby separation issue in December 2010. Note that this subject had been previously addressed by CABO/BCMC in 1986 with a similar conclusion. The code change proposals submitted are the result of the CTC's study of the issue. Note that the scope of the activity was as follows:

Scope

- Review the need for elevator lobbies, with emphasis on building use, building and hoistway height, active and passive fire protection features associated with the aforementioned.
- Review the differences and specific needs when dealing with elevator lobbies of traditional-use elevators, fire service elevators, and occupant evacuation elevators.
- Review related code provisions, such as egress from and through elevator lobbies.
- Review the appropriate use of alternatives including pressurization of hoistways, additional doors, roll-down style barriers, and gasketing systems.
- Review with members of elevator industry to scope the requirements of applicable elevator reference standards as it deals with elevator lobby design, use and construction.
- Review design and construction requirements for elevator lobbies, including but not limited to dimensions, location and separation.
- Review applicable code change history, technical studies and loss statistics as part of this review.

Based upon the extensive nature of this area of study, 5 Task Groups were formed during the process to provide in-depth review and to manage the number of issues. These task groups developed a number of proposals that were coordinated throughout the process.

More information on this CTC area of study can be found at the following link.
<http://www.iccsafe.org/cs/CTC/Pages/ElevatorLobbies.aspx>

The proposed language simply provides clarification as to where all the enclosed elevator lobby requirements are located in other portions of the code. Section 713.14.1.1 was revised to be consistent in approach to the new Sections 713.14.1.2 and 713.14.1.3. Sections 713.14.1.4 and 713.14.1.5 were added to be consistent with the concept of pointing to other relevant sections requiring enclosed elevator lobbies. If provisions are moved from Chapter 7 to Chapter 30 this proposal is no longer necessary.

This proposal will not be necessary if the provisions in 713.14.1 are moved to chapter 30. Other proposals such as the one revising to the elevator lobby exceptions to become permissions would require renumbering. Finally if the "where required provisions are heavily revised these sections may no longer be required. See discussion on CTC elevator lobby proposal coordination in code change FS##-12

Cost Impact: This code change proposal will not increase the cost of construction.

FS71-12

Public Hearing:	Committee:	AS	AM	D
	Assembly:	ASF	AMF	DF

713.14.1.1-FS-BALDASSARRA-CTC

FS72 – 12

714.2 (New)

Proponent: Renée R Jacobs, CHFM, CHC, Saint Luke's Health System

Revise as follows:

714.2 Contractor Qualifications. In buildings containing a Group I-2 occupancy, through-penetration firestop systems shall be installed by contractors qualified by UL, FM, or an approved agency.

Exception: Where the work is of a minor nature as approved by the building official.

(Renumber subsequent sections)

Reason: Proper design, installation, inspection, and maintenance of firestopping and fire-resistant joint systems are critical to fire and life safety in healthcare facilities. The life safety elements of healthcare facilities are critical to patient life and safety given that healthcare facilities defend-in-place in lieu of evacuate in the event of a fire. Accreditation entities surveying the life safety elements of healthcare facilities primarily focus on rated barriers and the integrity of the firestopping and joint installations within the rated barriers. The vast majority of findings by the accreditation surveyors are improperly installed UL systems and unsealed penetrations within the rated barriers, accounting for significant cost for corrections following a survey. Additionally, fire marshals are increasingly more educated in correct systems for different applications as well as proper installation, enforcing stricter compliance and increased extent of ramifications for non-compliance.

The extent of survey findings and deficiencies demonstrate a lack of knowledge of the correct systems and procedures for firestop and fire-resistive joint systems installation, which can be alleviated by requiring that all work be performed by a approved/qualified contractor.

The cost for corrections can be greatly reduced if the contractor is properly trained and approved/qualified. Initial construction costs remain the same for installation by an approved/qualified contractor, as the cost of approval/qualification is not substantial enough to pass along to the customer as a cost of the work. These costs can range from \$6,000 to \$10,000 for the initial audit and approximately \$3,000 annually for ongoing audits by Underwriters Laboratories and Factory Mutual, less than many contractors would spend on bidding a sizable project, attending a trade show, entertaining or advertising. Since any firm is eligible to obtain FM Approved Firestop Contractor and/or UL Qualified Firestop Contractor, experience shows that the main factor, the cost, can be recovered through the benefits of improved processes and reduced errors on projects.

Given that the contractor's cost for obtaining FM Approved Firestop Contractor and/or UL Qualified Firestop Contractor is minimal, the real factor is the on-going cost of repairs for incorrect or improperly installed systems, which remains a financial burden to most healthcare facilities. Annual outlay of capital dollars for continual corrections and repairs is commonplace for most healthcare facilities and is rarely even considered in the initial construction process.

Requiring installation of UL Firestop systems by approved/qualified firestop contractors is consistent with other code requirements mandating installation by certified contractors of other life safety systems such as medical gas systems certification of contractors and/or installers. Approval or qualification programs administered by approved agencies such as FM Approvals and Underwriters Laboratories currently exist for contractors who install materials that become firestop systems. Any contractor (trade or specialty firestop contractor) installing fire-resistant joint systems can be approved or qualified to the programs administered by these agencies. The programs are similar to ISO 9000 that is used for the manufacturing environment, but adjusted for the construction environment. Successful completion verifies that the company has policies and procedures in place that are sufficient to control operations resulting in installations conforming to the listed firestop system.

Availability of approved/qualified contractors that can easily attain the certification exists in virtually every state. Whereas the proposal is for the 2015 Edition of the IBC, it is reasonable to anticipate that many more contractors will participate in the programs prior to adoption of the Code.

Cost Impact: None

FS72-12

Public Hearing: Committee:	AS	AM	D
Assembly:	ASF	AMF	DF

714.2 (NEW)-FS-JACOBS

FS73 – 12

714.3 (New), 715.3 (New); ADMIN: 104.11.3 (New)

Proponent: James B. Smith, P.E., City of Waukesha Building Department, representing Wisconsin Code Officials Alliance (jsmith@ci.waukesha.wi.us)

Add new text as follows:

703.4 Engineering Judgments. Where the configuration of a penetrating item, group of items or a joint is such that a listed system is determined to be non-existent and reconfiguration of the penetrations or fire resistance rated assembly is determined to be impractical or impossible, alternative methods for maintaining the integrity of the required fire-resistance rating of the assembly shall be permitted to be established using an engineering analysis based on a comparison of listed systems prepared by a manufacturer's technical representative of the systems specified or prepared by the laboratory that conducted the original test. An engineering judgment shall be approved by the building official or an approved source where the information submitted is considered satisfactory. Approved engineering judgments shall be retained by the building official for the period required for retention of public records.

(Renumber subsequent sections)

714.3 Engineering Judgments. Where the configuration of a penetrating item or group of items is such that a listed system is determined to be non-existent and reconfiguration of the penetrations or fire resistance rated assembly is determined to be impractical or impossible, engineering judgments shall be permitted in accordance with Section 703.4.

(Renumber subsequent sections)

715.3 Engineering Judgments. Where the configuration of a joint is such that a listed system is determined to be non-existent and reconfiguration of the penetrations or fire resistance rated assembly is determined to be impractical or impossible, engineering judgments shall be permitted in accordance with Section 703.4.

(Renumber subsequent sections)

Reason: Engineering judgments are being used more often than necessary on construction projects. The code language that is currently being utilized to permit the use of engineering judgments is Section 104.11. Rather than relying on Section 104.11, I feel it is better to include expanded details specific to this type of engineering judgment within a newly created Section 703.4. The intent of the proposal is to provide reasonable parameter to limit the use of engineering judgments, restrict who may prepare an engineering judgment and to allow the approval of the engineering judgment to be by the building official or approved source when the documentation is considered to be acceptable. The last sentence of Section 703.4 has been provided to require retention of the engineering judgments consistent with what is required by existing text in Paragraph 104.11.2. In addition, the language is being proposed as new Sections 714.3 and 715.3 since those are the sections that address penetrations and joints.

Although there are over 8000 classified systems in the Underwriters Laboratories Fire Resistance Directory and thousands more in Intertek, FM Approvals and other laboratories listings, there are still configurations that appear at project sites that have no qualified system listed in a directory. That is particularly true when dealing with existing buildings that were constructed using materials that are outside the current norms that have been tested against. This is when the firestop contracting industry searches for advice from the manufacturer's headquarters technical personnel to seek a determination that a combination of systems that closely resembles the situation be suggested for approval from the manufacturer. Ultimately those are then forwarded to the code official for approval. As the Program Manager for the State of Wisconsin's commercial building program and the head of their material evaluation process, I was routinely called upon to review those "determinations" being proposed for use on projects in Wisconsin. In concert with Wisconsin laws on the practice of Architecture and Engineering I routinely called for those to be endorsed by the Wisconsin registered design or supervising professional (equivalent to "REGISTERED DESIGN PROFESSIONAL IN RESPONSIBLE CHARGE" – as defined in Section 202) for the project prior to my review. Knowing the widespread use of the IBC does not assure the same licensing/registration requirements will exist, I have not included that as a requirement within this proposal.

The end product of that service that is most usable by the code official is when it is performed by the manufacturer's qualified technical personnel who understand the fire performance of these products in systems or a representative of the testing laboratory, and provided they use the characteristics found in similar systems to make a determination about suitability for use of the products

in the specific application. The suggestions are then submitted by firestop manufacturer's technical staff through the contractor for approval. Using the knowledge from those who test the products frequently and understand their limitations, the manufacturer's technical personnel are expected to reference the closest possible tested system(s) to determine an appropriate method that provides a system closest to the field condition.

Those having the most experience with fire testing products at companies, as well as being the most removed from the sale of a specific product seem to be the manufacturer's technical personnel at headquarters locations. This Code language is needed to provide the building official transparency in the process when presented engineering judgments from the industry...only if a listed system cannot be found in the directories from any manufacturer...even if it means switching manufacturers for a few applications.

This Code language is needed to set some minimum parameters and requirements for when these determinations are permitted to be used, how these determinations (also known as Engineering Judgments or Equivalent Fire Resistance Rated Assemblies) are created, and who should be responsible for writing these determinations of suitability for use in specific applications.

Although alternative methods typically require approval by the building official, the proposal language also permits approval by an approved source (as defined in Section 202). Despite this language, on large projects there may still be a significant number of engineering judgments required and the need for the engineering judgment may be determined with relatively short lead time (due to changes that occur on the construction site). By including the language to allow approval of the engineering judgment by an approved source, pressure on code officials to grant approvals prior to installation can be reduced.

It should be noted that a separate proposal has been submitted by others to require submission of documents regarding how penetrations and joints are to be protected which should also reduce the need for engineering judgments.

During the last revision cycle various comments were raised ranging from how desperately this type of language is needed in the field to the thought that having such language will encourage an increased use of engineering judgments. I believe that by restricting the application to instances for which a listed system does not exist and by limiting who may prepare the engineering judgment there will not be an increase in the use of engineering judgments. Although the Code will now specifically permit engineering judgments, something permitted today by the Code as an alternative method, most manufacturers will continue to test applications that are commonly used in the field since there is still a cost involved in preparing engineering judgments and the use of engineering judgments has the potential to increase the construction time due to the specific approval required for an engineering judgment.

Cost Impact: None

FS73-12

Public Hearing:	Committee:	AS	AM	D
	Assembly:	ASF	AMF	DF

714.3 (NEW)-FS-SMITH

FS74 – 12

714.3.2

Proponent: Tony Crimi, A.C. Consulting Solutions Inc, representing International Firestop Council (tcrimi@sympatico.ca)

Revise as follows:

714.3.2 Membrane penetrations. Membrane penetrations shall comply with Section 714.3.1. Where walls or partitions are required to have a fire-resistance rating, recessed fixtures shall be installed such that the required fire-resistance will not be reduced.

Exceptions:

1. Membrane penetrations of maximum 2-hour fire-resistance-rated walls and partitions by steel electrical boxes that do not exceed 16 square inches (0.0103 m²) in area, provided the aggregate area of the openings through the membrane does not exceed 100 square inches (0.0645 m²) in any 100 square feet (9.29 m²) of wall area. The annular space between the wall membrane and the box shall not exceed 1/8 inch (3.1 mm). Such boxes on opposite sides of the wall or partition shall be separated by one of the following:
 - 1.1. By a horizontal distance of not less than 24 inches (610 mm) where the wall or partition is constructed with individual noncommunicating stud cavities;
 - 1.2. By a horizontal distance of not less than the depth of the wall cavity where the wall cavity is filled with cellulose loosefill, rockwool or slag mineral wool insulation;
 - 1.3. By solid fireblocking in accordance with Section 718.2.1;
 - 1.4. By protecting both outlet boxes with listed putty pads; or
 - 1.5. By other listed materials and methods.
2. Membrane penetrations by listed electrical boxes of any material, provided such boxes have been tested for use in fire-resistance-rated assemblies and are installed in accordance with the instructions included in the listing. The annular space between the wall membrane and the box shall not exceed 1/8 inch (3.1 mm) unless listed otherwise. Such boxes on opposite sides of the wall or partition shall be separated by one of the following:
 - 2.1. By the horizontal distance specified in the listing of the electrical boxes;
 - 2.2. By solid fireblocking in accordance with Section 718.2.1;
 - 2.3. By protecting both boxes with *listed* putty pads; or
 - 2.4. By other *listed* materials and methods.
3. Membrane penetrations by electrical boxes of any size or type, which have been *listed* as part of a wall opening protective material system for use in fire-resistance-rated assemblies and are installed in accordance with the instructions included in the listing.
4. Membrane penetrations by boxes other than electrical boxes, provided such penetrating items and the *annular space* between the wall membrane and the box, are protected by an *approved membrane penetration* firestop system installed as tested in accordance with ASTM E 814 or UL 1479, with a minimum positive pressure differential of 0.01 inch (2.49 Pa) of water, and shall have an F and T rating of not less than the required *fire-resistance rating* of the wall penetrated and be installed in accordance with their listing.
5. The *annular space* created by the penetration of an automatic sprinkler, provided it is covered by a metal escutcheon plate.
6. Membrane penetrations of maximum 2-hour fire resistance-rated walls and partitions by steel electrical boxes that exceed 16 square inches (0.0103 m²) in area, or steel electrical boxes of any size that exceed an aggregate area through the membrane of 100 square inches (0.0645 m²) in any 100 square feet (9.29 m²) of wall area, provided the wall or partition is constructed with individual non-communicating stud cavities, the *annular space* between the wall membrane and the box does not exceed 1/8 inch (3.1 mm), and provided:
 - 6.1. All electrical boxes within the stud cavity are protected by *listed* putty pads; or

6.2. All electrical boxes within the stud cavity are protected by other *listed* materials and methods.

Reason: This proposal reflects a very common current practice. It intends to permit an additional allowance for steel electrical boxes exceeding 16 square inches (0.0103 m²) in area, and exceeding an aggregate area through the membrane of 100 square inches (0.0645 m²) in any 100 square feet (9.29 m²) of wall area based on testing and listing of these devices in accordance with IBC requirements for membrane penetrations in Section 714.3.1.

Listings for protection of metallic Electrical Boxes specify the conditions under which they may be installed within fire-resistance-rated wall assemblies constructed with bearing and non-bearing wood or steel studs and wallboard membranes. The Listings for metallic outlet or switch boxes identify it is possible to install the boxes under less stringent conditions when such boxes are used in conjunction with tested firestop systems or devices. The individual Classifications indicate the specific applications and the method of installation for which the materials have been investigated.

Cost Impact: This change will reduce the cost of construction by permitting additional design options.

FS74-12

Public Hearing:	Committee:	AS	AM	D
	Assembly:	ASF	AMF	DF

714.3.2-FS-CRIMI

FS75 – 12

714.4.1.1.2

Proponent: Tony Crimi, A.C. Consulting Solutions Inc, representing International Firestop Council (tcrimi@sympatico.ca)

Revise as follows:

714.4.1.1.2 Through-penetration firestop system. *Through penetrations* shall be protected by an *approved through-penetration firestop system* installed and tested in accordance with ASTM E 814 or UL 1479, with a minimum positive pressure differential of 0.01 inch of water (2.49 Pa). The system shall have an F rating/T rating of not less than 1 hour but not less than the required rating of the floor penetrated.

Exceptions:

1. Floor penetrations contained and located within the cavity of a wall above the floor or below the floor do not require a T rating.
2. Floor penetrations by floor drains, tub drains or shower drains contained and located within the concealed space of a horizontal assembly do not require a T rating.
3. Floor penetrations of maximum 4-inch (102 mm) nominal diameter penetrating directly into metal-enclosed electrical power switchgear do not require a T rating.

Reason: This proposal intends to permit an additional exception for metallic EMT or conduit penetrating a horizontal assembly that directly enters a metal-enclosed power switchgear assembly. The National Electrical Code defines Metal-Enclosed Power Switchgear as a switchgear assembly completely enclosed on all sides and top with sheet metal (except for ventilating openings and inspection windows) and containing primary power circuit switching, interrupting devices, or both, with buses and connections. The assembly may include control and auxiliary devices. Access to the interior of the enclosure is provided by doors, removable covers, or both. These devices consist of a substantial metal structure and a sheet metal enclosure. The NEC further requires that, where installed over a combustibile floor, suitable protection to the floor must be provided, and requires clearances for cable conductors entering these enclosures. The unobstructed space opposite terminals or opposite raceways or cables entering a switchgear or control assembly must be adequate for the type of conductor and method of termination. Insulating these conduits or tubing creates a potential hazard, and requires derating of power cables. The condition below illustrates a typical installation:



Because these EMT goes through the floor and enters directly into these robust enclosures, it is reasonable to provide an exemption to the T-Rating requirements of the IBC in these conditions.

Cost Impact: This change will reduce the cost of construction.

FS75-12

Public Hearing: Committee:
Assembly:

AS
ASF

AM
AMF

D
DF

714.4.1.1.2-FS-CRIMI

FS76 – 12

714.4.1.2

Proponent: Sam Francis, American Wood Council (sfrancis@awc.org)

Revise as follows:

714.4.1.2 Membrane penetrations. Penetrations of membranes that are part of a *horizontal assembly* shall comply with Section 714.4.1.1.1 or 714.4.1.1.2. Where floor/ceiling assemblies are required to have a *fire resistance rating*, recessed fixtures shall be installed such that the required *fire resistance* will not be reduced.

Exceptions:

(No changes to Exceptions 1 through 6)

7. The ceiling membrane of 1- and 2-hour fire resistance- rated horizontal assemblies is permitted to be interrupted with the double wood top plate of a ~~fire-resistance-rated~~ wall assembly that is sheathed with Type X gypsum wallboard, provided that all penetrating items through the double top plates are protected in accordance with Section 714.4.1.1.1 or 714.4.1.1.2 and the ceiling membrane is tight to the top plates. ~~The fire-resistance-rating of the wall shall not be less than the rating of the horizontal assembly.~~

Reason: This is a common structural connection and prior to the 2012 edition the code had not prohibited where the floor structure rests on the top plate in wood frame construction. The requirement for similar rating should be left to the specific application in the code (where the code requires supporting construction to be rated the same as the construction being supported (depending on the type of floor or wall). As written, even nonbearing walls serving no fire protection purpose would have to be rated for up to 2 hours. A double top plate represents a minimum of 3 inches of solid wood at the point of interruption, representing no more hazard than the noncombustible penetrations permitted by Exceptions 1 and 2 of the section, since the annular space around such penetrations needs only protection against the passage of smoke and flame or nothing at all, since in the case of steel electrical boxes up to 1/8 inch of unprotected annular space is permitted. A ceiling running into double top plates provides superior protection in comparison.

Cost Impact: The code change proposal will not increase the cost of construction.

FS76-12

Public Hearing:	Committee:	AS	AM	D
	Assembly:	ASF	AMF	DF

714.4.1.2-FS-FRANCIS

FS77 – 12

715.4.2 (New)

Proponent: Tony Crimi, A.C. Consulting Solutions Inc, representing International Firestop Council (tcrimi@sympatico.ca)

Revise as follows:

715.4.2 Exterior curtain wall/vertical fire barrier intersections. Voids created at the intersection of nonfire-resistance rated exterior curtain wall assemblies and a fire-resistance-rated wall shall be filled. An approved material or system shall be used to fill the void, shall be securely installed in or on the intersection for its entire length so as not to dislodge, loosen or otherwise impair its ability to accommodate expected building movements and to retard the passage of fire and hot gases.

Reason: In the previous cycle, a Code change proposal was approved to 707.8 which clarified that the same requirement to protect the joint between a fire barrier and the underside of the floor also applies to the joint between a fire barrier and an exterior wall. The language in the 2012 IBC points the user to compliance with section 715. However, the IBC does not specifically address the intersection of non-fire-resistance rated exterior curtain walls to rated fire barriers. The proposed language provides clear performance requirements that can be applied and enforced in these conditions. It is similar to the language in other sections of the IBC for voids created between rated and unrated assemblies..

Cost Impact:

FS77-12

Public Hearing:	Committee:	AS	AM	D
	Assembly:	ASF	AMF	DF

705.4.2 (NEW)-FS-CRIMI

FS78 – 12

715.2 (New)

Proponent: Renée R Jacobs, CHFM, CHC, Saint Luke's Health System

Revise as follows:

715.2 Contractor Qualifications. In buildings containing a Group I-2 occupancy, fire-resistant joint systems shall be installed by contractors qualified by UL, FM, or an approved agency.

Exception: Where the work is of a minor nature as approved by the building official.

(Renumber subsequent sections)

Reason: Proper design, installation, inspection, and maintenance of firestopping and fire-resistant joint systems are critical to fire and life safety in healthcare facilities. The life safety elements of healthcare facilities are critical to patient life and safety given that healthcare facilities defend-in-place in lieu of evacuate in the event of a fire. Accreditation entities surveying the life safety elements of healthcare facilities primarily focus on rated barriers and the integrity of the firestopping and joint installations within the rated barriers. The vast majority of findings by the accreditation surveyors are improperly installed UL systems and unsealed penetrations within the rated barriers, accounting for significant cost for corrections following a survey. Additionally, fire marshals are increasingly more educated in correct systems for different applications as well as proper installation, enforcing stricter compliance and increased extent of ramifications for non-compliance.

The extent of survey findings and deficiencies demonstrate a lack of knowledge of the correct systems and procedures for firestop and fire-resistive joint systems installation, which can be alleviated by requiring that all work be performed by a approved/qualified contractor.

The cost for corrections can be greatly reduced if the contractor is properly trained and approved/qualified. Initial construction costs remain the same for installation by an approved/qualified contractor, as the cost of approval/qualification is not substantial enough to pass along to the customer as a cost of the work. These costs can range from \$6,000 to \$10,000 for the initial audit and approximately \$3,000 annually for ongoing audits by Underwriters Laboratories and Factory Mutual, less than many contractors would spend on bidding a sizable project, attending a trade show, entertaining or advertising. Since any firm is eligible to obtain FM Approved Firestop Contractor and/or UL Qualified Firestop Contractor, experience shows that the main factor, the cost, can be recovered through the benefits of improved processes and reduced errors on projects.

Given that the contractor's cost for obtaining FM Approved Firestop Contractor and/or UL Qualified Firestop Contractor is minimal, the real factor is the on-going cost of repairs for incorrect or improperly installed systems, which remains a financial burden to most healthcare facilities. Annual outlay of capital dollars for continual corrections and repairs is commonplace for most healthcare facilities and is rarely even considered in the initial construction process.

Requiring installation of UL Firestop systems by approved/qualified firestop contractors is consistent with other code requirements mandating installation by certified contractors of other life safety systems such as medical gas systems certification of contractors and/or installers. Approval or qualification programs administered by approved agencies such as FM Approvals and Underwriters Laboratories currently exist for contractors who install materials that become firestop systems. Any contractor (trade or specialty firestop contractor) installing fire-resistant joint systems can be approved or qualified to the programs administered by these agencies. The programs are similar to ISO 9000 that is used for the manufacturing environment, but adjusted for the construction environment. Successful completion verifies that the company has policies and procedures in place that are sufficient to control operations resulting in installations conforming to the listed firestop system.

Availability of approved/qualified contractors that can easily attain the certification exists in virtually every state. Whereas the proposal is for the 2015 Edition of the IBC, it is reasonable to anticipate that many more contractors will participate in the programs prior to adoption of the Code.

Cost Impact: None

FS78-12

Public Hearing:	Committee:	AS	AM	D
	Assembly:	ASF	AMF	DF

715.2 (NEW)-FS-JACOBS

FS79 – 12

715.4

Proponent: Vickie Lovell, InterCode Incorporated representing the 3M Company
(vickie@intercodeinc.com)

Revise as follows:

715.4 Exterior curtain wall/floor intersection. Where fire resistance-rated floor or floor/ceiling assemblies are required, voids created at the intersection of the exterior curtain wall assemblies and such floor assemblies shall be sealed with an *approved* system to prevent the interior spread of fire. Such systems shall be securely installed and tested in accordance with ASTM E 2307 to provide an *F rating* for a time period at least equal to the *fire-resistance rating* of the floor assembly. Height and fire-resistance requirements for curtain wall spandrels shall comply with Section 705.8.5.

Exception: Voids created at the intersection of the exterior curtain wall assemblies and such floor assemblies where the vision glass extends to the finished floor level shall be permitted to be sealed with an approved material to prevent the interior spread of fire. Such material shall be securely installed, and shall be capable of accommodating the dynamic movement cycles associated with wind sway, thermal expansion and contraction, and seismic movement appropriate for the building height and design. Such material shall be capable of preventing the passage of flame and hot gases sufficient to ignite cotton waste where subjected to ASTM E 119 time-temperature fire conditions under a minimum positive pressure differential of 0.01 inch (0.254 mm) of water column (2.5 Pa) for the time period at least equal to the *fire-resistance rating* of the floor assembly.

Reason: This proposal seeks to clarify the language the 2009 Fire Safety Committee approved when they added an exception to the requirement to test perimeter joints ASTM E 2307.

In reality, this exception as written is inadequate, and should be removed altogether because it creates two paths to compliance, two test methods that are not equivalent, and a myriad of subjective ways to determine compliance with the code section. However, if the 2012 Fire Safety Committee is inclined to keep this ambiguous exception in the code, then some additional language that resembles the intent of ASTM E 2307 is needed to keep from having two completely different acceptance and performance criteria for this intersection.

ASTM E119 is not, nor has it ever been, the appropriate single test for materials for use in such a dynamic location because it only addressed the fire resistance properties of the materials tested. In 2004, the standard ASTM E 2307 "Standard Test Method for Determining Fire Resistance of Perimeter Fire Barriers Using Intermediate-Scale, Multi-story Test Apparatus" was developed after more than a decade of work to specifically test this intersection. This test more accurately replicates the conditions of this unique joint, which is unlike any other opening.

During the 2006 cycle, the Fire Safety Committee approved language that completely removed the reference to ASTM E 119, and replaced it with the appropriate reference to ASTM E 2307 (FS111-07/08). The reason they provided is as follows:

The committee agreed that the single applicable standard to the test exterior curtain wall and floor intersection is ASTM E2307. This standard, unlike ASTM E119 and UL 263, addresses the unique construction details associated with the exterior curtain wall and floor intersections.

The fire exposure conditions used in ASTM E 2307 to evaluate the perimeter joint system as follows:

- the vertical passage of flames and hot gases at the building's exterior perimeter (incorporates the ASTM E119 time-temperature curve).
- the transmission of heat, flame and hot gases through the perimeter joint system.
- the movement capacity of the perimeter joint system for anticipated building movement from wind sway, seismic activity, wind loading and thermal expansion and contraction.
- the load bearing capacity of the perimeter joint system.

The construction materials used in the exterior wall is irrelevant and should not be a consideration. The test is for the void. This proposal adds similar performance requirements from ASTM E 2307 to the exception.

Cost Impact: The code change proposal will not increase the cost of construction.

FS79-12

Public Hearing:	Committee:	AS	AM	D
	Assembly:	ASF	AMF	DF

715.4 #2-FS-LOVELL

FS80 – 12

715.4

Proponent: Vickie Lovell, InterCode Incorporated representing the 3M Company
(vickie@intercodeinc.com)

Revise as follows:

715.4 Exterior curtain wall/floor intersection. Where fire resistance-rated floor or floor/ceiling assemblies are required, voids created at the intersection of the exterior curtain wall assemblies and such floor assemblies shall be sealed with an *approved* system to prevent the interior spread of fire. Such systems shall be securely installed and tested in accordance with ASTM E 2307 to provide an *F rating* for a time period at least equal to the *fire-resistance rating* of the floor assembly. Height and fire-resistance requirements for curtain wall spandrels shall comply with Section 705.8.5.

~~**Exception:** Voids created at the intersection of the exterior curtain wall assemblies and such floor assemblies where the vision glass extends to the finished floor level shall be permitted to be sealed with an approved material to prevent the interior spread of fire. Such material shall be securely installed and capable of preventing the passage of flame and hot gases sufficient to ignite cotton waste where subjected to ASTM E 119 time temperature fire conditions under a minimum positive pressure differential of 0.01 inch (0.254 mm) of water column (2.5 Pa) for the time period at least equal to the *fire-resistance rating* of the floor assembly.~~

Reason: This proposal seeks to restore the original language that was approved by the Fire Safety Committee for the 2009 IBC before this exception was added.

The legacy codes and the 1999-2006 International Building Code addressed the fire protection of the linear void at the intersection of the fire rated floor and the exterior curtain wall using the only criteria that was available at the time, the ASTM E119 time/temperature curve.

However, ASTM E119 alone is not, nor has it ever been, the appropriate test for materials to for use in such a dynamic locations because it only addressed the fire resistance properties of the materials tested. In 2004, the standard ASTM E2307 "Standard Test Method for Determining Fire Resistance of Perimeter Fire Barriers Using Intermediate-Scale, Multi-story Test Apparatus" was developed after more than a decade of work. This test more accurately replicates the conditions of this unique joint, which is unlike any other opening.

A perimeter joint system is a unique type of fire-resistive joint system that provides fire resistance to prevent passage of fire from floor to floor within the building at the opening between the exterior wall assembly and the floor assembly, which is not addressed by ASTM E1966, which is used to test other types of joints.

A perimeter joint system also prescribes a unique building construction detail, the intermediate-scale, multistory test apparatus (ISMA). It is not addressed by any fire test method, including ASTM E 119. ASTM E2307 describes criteria and test methods used to determine the fire resistance of perimeter joint system when subjected to standard fire exposure conditions using the intermediate-scale, multistory test apparatus (ISMA). The use of the multi-story test apparatus and this test method are intended to simulate a possible fire exposure on a perimeter joint system. It measures the performance of the perimeter joint system and its ability to maintain a seal to prevent fire spread during the deflection and deformation of the exterior wall assembly and floor assembly during the fire test, while resisting fire exposure from an interior compartment fire as well as from the flame plume emitted from the window burner below. The end point of the fire-resistance test is the period of time elapsing before the first condition of compliance is reached as the perimeter joint system is subjected to a time-temperature fire exposure.

The fire exposure conditions used in ASTM E2307 incorporates the ASTM E119 time-temperature curve, to determine the ability of the perimeter joint system to resist the vertical passage of flames and hot gases at the building's exterior perimeter, but the test method also identifies:

- The transmission of heat through the perimeter joint system.
- The movement capacity of the perimeter joint system for anticipated building movement from wind sway, seismic activity, wind loading and thermal expansion and contraction.
- The load bearing capacity of the perimeter joint system.

During the 2006 cycle, the Fire Safety Committee approved language that completely removed the reference to ASTM E119, and replaced it with the appropriate reference to ASTM E2307 (FS111-07/08). The reason they provided is as follows:

The committee agreed that the single applicable standard to the test exterior curtain wall and floor intersection is ASTM E2307. This standard, unlike ASTM E119 and UL 263, addresses the unique construction details associated with the exterior curtain wall and floor intersections.

This exception should be removed because it creates two paths to compliance, two test methods that are not equivalent, and a myriad of subjective ways to determine compliance with the code section.

Cost Impact: This code change will not increase the cost of construction and may in fact reduce the cost of construction.

FS80-12

Public Hearing:	Committee:	AS	AM	D
	Assembly:	ASF	AMF	DF

715.4 #1-FS-LOVELL

FS81 – 12

715.7 (New)

Proponent: Tony Crimi, A.C. Consulting Solutions Inc, representing International Firestop Council (tcrimi@sympatico.ca)

Add new text as follows:

715.7 Dissimilar materials. Joints installed in or between fire-resistance-rated walls or horizontal assemblies consisting of two or more assemblies of dissimilar materials shall be protected by an approved fire-resistant joint system complying with Section 715.3.

Reason: There are several instances within the IBC that provide specific guidance on the requirements governing the interaction of dissimilar materials. Specific examples are included in Sections 714, 722 and 1403. There is a need to provide specific requirements for assemblies complying with the both Sections 703 (tested) and Section 721 (calculated) fire resistance ratings. This proposal clarifies the application of Section 715 to joints between dissimilar fire-resistance rated wall, floor or ceiling assembly materials used adjacent to one another. There are numerous systems which have been tested by nationally recognized testing organizations for these applications. Information concerning these details is described in the individual systems.

Joint systems are installed in joints, voids, gaps, or other discontinuities between or bounded by two or more fire-resistance rated elements. When these assemblies are tested and listed to ASTM E119 in order to obtain their fire resistance rating, the testing/listing includes the joints that would normally occur within the floor, wall or ceiling, which would bind together and provide continuity between independent units of the same building material, such as the compound and tape joints between gypsum boards, or the mortared joints between concrete masonry units. However, the joint that could occur when that floor, wall or ceiling intersects another assembly of a different material is not anticipated nor accounted for in the E119 test. Preventing fire spread through the joint between such dissimilar materials is in fact the principle reason for testing fire-resistance rated joint systems to ASTM E1996, UL 2079. This code change would help to clarify that it is these joints between dissimilar materials/assemblies that require a joint system tested for each desired combination of materials.

Cost Impact: This code change will not increase the cost of construction.

FS81-12

Public Hearing:	Committee:	AS	AM	D
	Assembly:	ASF	AMF	DF

715.7-FS-CRIMI

FS82 – 12

707.5, 707.9, 717.9, 711.4.1, 707.9, 711.6, 711.9, 712.1.17, 715, 715.1, 715.4.1, 715.5, 715.6, Chapter 35

Proponent: Tony Crimi, A.C. Consulting Solutions, representing International Firestop Council; Gary Hamilton, Hamilton Benchmark; William Koffel, P.E., Koffel Associates; John Valiulis, Hilti, Inc (john.valiulis@hilti.com)

Revise as follows:

707.5 Continuity. Fire barriers shall extend from the top of the foundation or floor/ceiling assembly below to the underside of the floor or roof sheathing, slab or deck above and shall be securely attached thereto. Such fire barriers shall be continuous through concealed space, such as the space above a suspended ceiling. Joints ~~and voids at intersections~~ shall comply with Sections 707.8 and 707.9

707.9 Joints. Joints at the intersection of fire barriers and the underside of a non-fire resistance rated floor or roof sheathing, slab or deck above, shall comply with 715.4

711.6 Joints. Joints made in or between horizontal assemblies shall comply with Section 715.1. The void created at the intersection of a floor/ceiling assembly and an exterior curtain wall assembly shall be protected in accordance with Section ~~715.4~~ 715.2.

711.9 Smoke barrier. Where horizontal assemblies are required to resist the movement of smoke by other sections of this code in accordance with the definition of smoke barrier, penetrations and joints in such horizontal assemblies shall be protected as required for smoke barriers in accordance with Sections 714.5 and 715.1.6. Regardless of the number of stories connected by elevator shaft enclosures, doors located in elevator shaft enclosures that penetrate the horizontal assembly shall be protected by enclosed elevator lobbies complying with Section 713.14.1. Openings through horizontal assemblies shall be protected by shaft enclosures complying with Section 713. Horizontal assemblies shall not be allowed to have unprotected vertical openings.

712.1.17 Nonfire-resistance-rated joints. Joints in or between floors without a required fire-resistance rating shall be permitted in accordance with Section ~~715.64.4.1~~ 715.64.4.1.

SECTION 715 FIRE-RESISTANT JOINT SYSTEMS PROTECTION OF JOINTS

715.1 Joints in or between systems fire resistance rated assemblies. Joints in or between fire resistance rated assemblies shall comply with Sections 715.1.1 through 715.1.4.

~~715.1~~ **715.1.1 General.** Joints ~~installed~~ in or between fire-resistance rated walls, floor or floor/ceiling assemblies and roofs or roof/ceiling assemblies shall be protected by an approved *fire-resistant joint system* designed to prevent ~~resist~~ the passage of fire flames, excessive heat, and hot gases for a time period not less than the required *fire-resistance rating* of the wall, floor or roof in or between which it is installed. *Fire-resistant joint systems* shall be tested in accordance with Section 715.1.3.

Exception: *Fire-resistant joint systems* shall not be required for joints in all of the following locations:

1. Floors within a single *dwelling unit*.
2. Floors where the joint is protected by a shaft enclosure in accordance with Section 713.
3. Floors within atriums where the space adjacent to the atrium is included in the volume of the atrium for smoke control purposes.
4. Floors within malls.

5. Floors and ramps within open and enclosed parking garages or structures constructed in accordance with Sections 406.5 and 406.6, respectively.
6. Mezzanine floors.
7. Walls that are permitted to have unprotected openings.
8. Roofs where openings are permitted.
9. Control joints not exceeding a maximum width of 0.625 inch (15.9 mm) and tested in accordance with ASTM E119 or UL263.

715.1.1 ~~Curtain wall assembly.~~ ~~The void created at the intersection of a floor/ceiling assembly and an exterior curtain wall assembly shall be protected in accordance with Section 715.4.~~

715.2 ~~715.1.2~~ Installation. A fire-resistant joint system shall be securely installed in accordance with the listing criteria in or on the joint for its entire length so as not to dislodge, loosen or otherwise impair its ability to accommodate expected building movements and to resist the passage of fire and hot gases.

715.3 ~~715.1.3~~ Fire test criteria. Fire-resistant joint systems shall be tested in accordance with the requirements of either ASTM E 1966 or UL 2079. Nonsymmetrical wall joint systems shall be tested with both faces exposed to the furnace, and the assigned fire-resistance rating shall be the shortest duration obtained from the two tests. When evidence is furnished to show that the wall was tested with the least fire-resistant side exposed to the furnace, subject to acceptance of the building official, the wall need not be subjected to tests from the opposite side.

Exception: For exterior walls with a horizontal fire separation distance greater than 5 feet (1524 mm), the joint system shall be required to be tested for interior fire exposure only.

715.6 ~~715.1.4~~ Fire-resistant joint systems in smoke barriers. *Fire-resistant joint* systems in or between smoke barriers, ~~and joints at the intersection of a horizontal smoke barrier and an exterior curtain wall,~~ shall be tested in accordance with the requirements of UL 2079 for air leakage. The L rating of the joint system shall not exceed 5 cfm per linear foot (0.00775 m³/s m) of joint at 0.30 inch (7.47 Pa) of water for both the ambient temperature and elevated temperature test.

715.4 ~~715.2~~ Exterior curtain wall/floor intersection. Joints between fire-resistance rated floor assemblies and curtain walls. Joints between curtain walls and floor or floor/ceiling assemblies that are required to be fire resistance rated shall comply with Sections 715.2.1 through 715.2.3.

715.2.1 Fire resistance-rated floor or floor/ceiling assemblies. Where fire resistance-rated floor or floor/ceiling assemblies are required, voids created at the intersection of the exterior curtain wall assemblies and such floor assemblies shall be sealed with an approved system to prevent the interior spread of fire. Such systems shall be securely installed and tested in accordance with ASTM E 2307 to provide an F rating for a time period at least equal to the fire-resistance rating of the floor assembly. Height and fire-resistance requirements for curtain wall spandrels shall comply with Section 705.8.5.

Exception: Voids created at the intersection of the exterior curtain wall assemblies and such floor assemblies where the vision glass extends to the finished floor level shall be permitted to be sealed with an approved material to prevent the interior spread of fire. Such material shall be securely installed and capable of preventing the passage of flame and hot gases sufficient to ignite cotton waste where subjected to ASTM E 119 time-temperature fire conditions under a minimum positive pressure differential of 0.01 inch (0.254 mm) of water column (2.5 Pa) for the time period at least equal to the fire-resistance rating of the floor assembly.

715.5 ~~715.2.2~~ Spandrel wall. Height and fire-resistance requirements for curtain wall spandrels shall comply with Section 705.8.5. Where Section 705.8.5 does not require a fire-resistance rated spandrel wall, the requirements of Section 715.2.14 shall still apply to the intersection between the spandrel wall and the floor.

715.2.3 Joints at the intersection of a horizontal smoke barrier and an exterior curtain wall. Joints at the intersection of a horizontal smoke barrier and an exterior curtain wall shall be tested in accordance with the requirements of UL 2079 for air leakage. The L rating of the joint system shall not exceed 5 cfm per linear foot (0.00775 m³/s m) of joint at 0.30 inch (7.47 Pa) of water for both the ambient temperature and elevated temperature tests.

715.3 Joints between fire resistance rated walls and non-fire resistance rated floors or roofs. Joints between fire barriers and non-fire resistance rated floors or roofs shall comply with Sections 715.3.1 and 715.3.2.

715.3.1 Fire test criteria. Joints at the intersection of fire barriers with the underside of a non-fire resistance rated floor or roof sheathing, slab or deck above shall be protected by an approved continuity head of wall joint system installed as tested in accordance with ASTM E2837 and designed to resist the passage of fire for a time period not less than the required fire resistance rating of the wall in which it is installed.

715.3.2 Installation. Continuity head of wall joint systems shall be securely installed in or on the joint for its entire length so as not to dislodge, loosen or otherwise impair its ability to accommodate expected building movements and to retard the passage of fire and hot gases.

707.9 715.4 Voids at intersections Joints between fire resistance rated walls and non-fire resistance rated walls. The voids created at the intersection of a fire barrier and a non-fire-resistance-rated wall shall be filled. An approved material or system shall be used to fill the void, shall be securely installed in or on the intersection for its entire length so as not to dislodge, loosen or otherwise impair its ability to accommodate expected building movements and to retard the passage of fire and hot gases.

715.4.4 715.5 Exterior curtain wall/nonfire-resistance-rated floor assembly intersections Joints between non-fire resistance rated floors and curtain walls. Voids created at Joints between the intersection of exterior curtain wall assemblies and nonfire-resistance-rated floor or floor/ceiling assemblies shall be sealed with an approved material or system to retard the interior spread of fire and hot gases between stories.

714.4.4 715.6 Nonfire-resistance-rated assemblies Joints within non-fire resistance rated floors. Joints in or between floor assemblies without a required fire-resistance rating shall comply with one of the following:

1. The joint shall be concealed within the cavity of a wall.
2. The joint shall be located above a ceiling.
3. The joint shall be sealed, treated or covered with an approved material or system to resist the free passage of flame and the products of combustion.

Exception: Joints meeting one of the joint exceptions listed in Section 715.1.

Add new standard as follows to Chapter 35:

ASTM	ASTM International 100 Barr Harbor Drive West Conshohocken, PA 19428-2959
E 2634—08	Standard Specification for Flat Wall Insulating Concrete Form (ICF) Systems1903.3
<u>E2837 – 11</u>	<u>Standard Test Method for Determining the Fire Resistance of Continuity Head-Of-Wall Joint Systems Installed Between Rated Wall Assemblies and Nonrated Horizontal Assemblies715.3</u>
F 547—06	Terminology of Nails for Use with Wood and Wood-based MaterialsTable 2506.2

Reason: Section 715 organization is revised as follows, to group the rules for any given application together, and to draw clear distinctions between each one of them.

- 715.1 JOINTS IN OR BETWEEN FIRE RESISTANCE RATED ASSEMBLIES
- 715.2 JOINTS BETWEEN FIRE RESISTANCE RATED FLOOR ASSEMBLIES AND CURTAIN WALLS
- 715.3 JOINTS BETWEEN FIRE RESISTANCE RATED WALLS AND NON-FIRE RESISTANCE RATED FLOORS OR ROOFS
- 715.4 JOINTS BETWEEN FIRE RESISTANCE RATED WALLS AND NON-FIRE RESISTANCE RATED WALLS
- 715.5 JOINTS BETWEEN NON-FIRE RESISTANCE RATED FLOORS AND CURTAIN WALLS
- 715.6 JOINTS WITHIN NON-FIRE RESISTANCE RATED FLOORS

Almost all of the code requirements are exactly as in the 2012 IBC, except moved to the appropriate new sub-section of 715. Section 715.3 is new, to incorporate the testing to the 2011-issued ASTM standard E2837. Referencing the test standard should mostly avoid the need for AHJ's to be given engineering judgments to evaluate for that same application, as the existence of the ASTM fire test and corresponding listings from UL will allow standardized, tested and listed designs to be used. The performance requirements for the joint are listed in 715.3.2, which are identical to what IBC 2012 article 707.9 required for the performance of that same joint. Thus, the only real addition is the addition of 715.3.1, which references the ASTM test standard, thus allowing the AHJ to expect some documented proof that the proposed design does meet the performance requirements as enumerated in IBC 2012.

The charging statements in the earlier parts of Chapter 7 that have pointed to sections or articles within 715 are modified to correct the articles to which they need to reference in the proposed, reorganized section 715.

715.1.1:

The change that now proposes to reference that a fire-resistive joint system will prevent the passage of "flames, excessive heat, and hot gases" and not just "fire" is made in order to harmonize with the IBC definition of fire resistance. The test method tests for all three, so adding this verbiage does not add any new requirements that have not always been complied with when testing to ASTM E1966 or UL 2079.

Cost Impact: Will not increase the cost of construction.

Analysis: A review of the standard proposed for inclusion in the code, ASTM E2837-11 with regard to the ICC criteria for referenced standards (Section 3.6 of CP#28) will be posted on the ICC website on or before April 2, 2012.

FS82-12

Public Hearing:	Committee:	AS	AM	D
	Assembly:	ASF	AMF	DF

707.5-FS-CRIMI-HAMILTON-KOFFEL-VALIULIS

FS83 – 12

716.2

Proponent: Carl Baldassarra, P.E., FSFPE, Chair, ICC Code Technology Committee

Revise as follows:

716.2 Fire-resistance-rated glazing. Fire-resistance-rated glazing tested as part of a fire-resistance-rated wall or floor/ceiling assembly in accordance with ASTM E 119 or UL 263 and labeled in accordance with Section 703.6 shall be permitted in fire doors and fire window assemblies where tested and installed in accordance with their listings and shall not otherwise be required to comply with this section when used as part of a wall or floor/ceiling assembly. Fire-resistance-rated glazing shall be permitted in fire door and fire window assemblies where tested and installed in accordance with their listings and when in compliance with the requirements of this section.

Reason: The ICC Board established the ICC Code Technology Committee (CTC) as the venue to discuss contemporary code issues in a committee setting which provides the necessary time and flexibility to allow for full participation and input by any interested party. The code issues are assigned to the CTC by the ICC Board as “areas of study”. Information on the CTC, including: meeting agendas; minutes; reports; resource documents; presentations; and all other materials developed in conjunction with the CTC effort can be downloaded from the following website: <http://www.iccsafe.org/cs/CTC/Pages/default.aspx>. Since its inception in April/2005, the CTC has held twenty two meetings - all open to the public.

This proposed change is a result of the CTC’s investigation of the area of study entitled “Labeling of Fire Rated Glazing”. The scope of the activity is noted as:

Identify root causes of problems selecting, specifying, installing, and inspecting fire protective and fire resistive glazing and other assembly components including the frames. Propose identification requirements and other related code changes.

The changes proposed for Section 716.2 clarify how the code currently provides fire-resistance-rated glazing. The modifications to the first sentence clarify that when fire-resistance-rated glazing tested in accordance with ATM E119 and used as part of a wall or floor/ceiling assembly, it is not subject to the provisions of Section 716.

However, the second sentence clarifies that when fire-resistance-rated glazing is used as part of a fire door or fire window assembly there are provisions in Section 716 that apply to its use. As currently worded the user could be misled as to the application of the additional requirements for applications involving fire door and window assemblies.

Cost Impact: The code change proposal will not increase the cost of construction.

FS83-12

Public Hearing:	Committee:	AS	AM	D
	Assembly:	ASF	AMF	DF

716.2-FS-BALDASSARRA-CTC

FS84 – 12

716.3.1, 716.3.2 (New), 716.5.8.3, 716.5.8.3.1 and 716.6.8

Proponent: Carl Baldassarra, P.E., FSFPE, Chair, ICC Code Technology Committee

Revise as follows:

716.3 Marking fire-rated glazing assemblies. *Fire-rated glazing* assemblies shall be marked in accordance with Tables 716.3, 716.5, and 716.6.

716.3.1 Identification. For fire-rated glazing, the *label* shall bear the identification required in Table 716.3 and Table 716.5. “D” indicates that the glazing is permitted to be used in *fire door* assemblies and that the glazing meets the fire protection requirements of NFPA 252. “H” shall indicate that the glazing meets the hose stream requirements of NFPA 252. “T” shall indicate that the glazing meets the temperature requirements of Section 716.5.5.1. The placeholder “XXX” represents the fire -rating period, in minutes.

716.3.2 Identification. For fire-protection-rated glazing, the *label* shall bear the following identification required in Table 716.3 and Table 716.6: “OH – XXX.” “OH” indicates that the glazing meets both the fire protection and the hose-stream requirements of NFPA257 or UL9 and is permitted to be used in fire window openings. The placeholder “XXX” represents the fire-rating period, in minutes.

716.3.4 716.3.3 Fire-rated glazing that exceeds the code requirements. *Fire-rated glazing* assemblies marked as complying with hose stream requirements (H) shall be permitted in applications that do not require compliance with hose stream requirements. *Fire-rated glazing* assemblies marked as complying with temperature rise requirements (T) shall be permitted in applications that do not require compliance with temperature rise requirements. *Fire-rated glazing* assemblies marked with ratings (XXX) that exceed the ratings required by this code shall be permitted.

716.5.8.3 Labeling. Fire-protection-rated glazing shall bear a *label* or other identification showing the name of the manufacturer, the test standard and information required in Section 716.3.1 716.5.8.3.4 that shall be issued by an *approved agency* and shall be permanently identified on the glazing.

716.5.8.3.1 Identification. For fire-protection-rated glazing, the *label* shall bear the following four-part identification: “D H or NH T or NT XXX.” “D” indicates that the glazing shall be used in *fire door* assemblies and that the glazing meets the fire protection requirements of NFPA 252. “H” shall indicate that the glazing meets the hose stream requirements of NFPA 252. “NH” shall indicate that the glazing does not meet the hose stream requirements of the test. “T” shall indicate that the glazing meets the temperature requirements of Section 716.5.5.1. “NT” shall indicate that the glazing does not meet the temperature requirements of Section 716.5.5.1. The placeholder “XXX” shall specify the fire-protection-rating period, in minutes.

716.6.8 Labeling requirements. Fire-protection-rated glazing shall bear a label or other identification showing the name of the manufacturer, the test standard and information required in Section 716.3.2 and Table 716.6 that shall be issued by an approved agency and shall be permanently identified on the glazing.

Reason: The ICC Board established the ICC Code Technology Committee (CTC) as the venue to discuss contemporary code issues in a committee setting which provides the necessary time and flexibility to allow for full participation and input by any interested party. The code issues are assigned to the CTC by the ICC Board as “areas of study”. Information on the CTC, including: meeting agendas; minutes; reports; resource documents; presentations; and all other materials developed in conjunction with the CTC effort can be downloaded from the following website: <http://www.iccsafe.org/cs/CTC/Pages/default.aspx>. Since its inception in April/2005, the CTC has held twenty two meetings - all open to the public.

This proposed change is a result of the CTC’s investigation of the area of study entitled “Labeling of Fire Rated Glazing”. The scope of the activity is noted as:

Identify root causes of problems selecting, specifying, installing, and inspecting fire protective and fire resistive glazing and other assembly components including the frames. Propose identification requirements and other related code changes.

The proposed changes to Section 716.3 (the addition of Section 716.3.1 and 716.3.2) clarify the requirements for marking of fire-rated glazing assemblies. No technical changes are being introduced.

Section 716.3.1 was moved from Section 716.5.8.3.1. The language was modified to clarify that the provisions of the section apply to fire-rated glazing used in fire door assemblies. Additionally, consistent with Tables 716.3 and Table 716.5, the language was modified to reflect the fact that fire-rated glazing assemblies that do not meet the temperature or hose stream requirements of this section are not required to be labeled as "NT" and "NH" respectively.

Section 716.3.2 was added to clarify that Tables 716.3 and 716.6 are the appropriate tables to be used for fire-protection-rated glazing, and to provide details of the required label and standards for performance, consistent with such tables. This section essentially reflects the same language as contained in Section 715.5.9.1 of the 2009 IBC.

The remaining changes are made to update cross-references to reflect the new section numbers.

Cost Impact: The code change proposal will not increase the cost of construction.

FS84-12

Public Hearing:	Committee:	AS	AM	D
	Assembly:	ASF	AMF	DF

716.3-FS-BALDASSARRA-CTC

FS85 – 12

Table 716.5

Proponent: Carl Baldassarra, P.E., FSFPE, Chair, ICC Code Technology Committee

Revise as follows:

**TABLE 716.5
OPENING FIRE PROTECTION ASSEMBLIES, RATINGS AND MARKINGS**

TYPE OF ASSEMBLY	REQUIRED WALL ASSEMBLY RATING (hours)	MINIMUM FIRE DOOR AND FIRE SHUTTER ASSEMBLY RATING (hours)	DOOR VISION PANEL SIZE ^b	FIRE RATED GLAZING MARKING DOOR VISION PANEL ^{e,d}	MINIMUM SIDELIGHT/TRANSOM ASSEMBLY RATING (hours)		FIRE-RATED GLAZING MARKING SIDELITE/TRANSOM PANEL	
					Fire protection	Fire resistance	Fire protection	Fire resistance
Fire walls and fire barriers having a required fire-resistance rating greater than 1 hour	4	3	Not Permitted See note <u>b</u>	Not Permitted <u>D-H-W-240</u>	Not Permitted	4	Not Permitted	W-240
	3	3 ^a	Not Permitted See note <u>b</u>	Not Permitted <u>D-H-W-180</u>	Not Permitted	3	Not Permitted	W-180
	2	1½	100 sq. in. ^e	<input type="checkbox"/> 100 sq.in. = D-H-90 >100 sq.in.= D-H-W-90	Not Permitted	2	Not Permitted	W-120
	1½	1½	100 sq. in. ^e	<input type="checkbox"/> 100 sq.in. = D-H-90 >100 sq.in.= D-H-W-90	Not Permitted	1½	Not Permitted	W-90
<u>Horizontal exits in fire walls</u> ^a	<u>4</u>	<u>3</u>	<u>100 sq. in.</u>	<input type="checkbox"/> 100 sq.in. = D-H-180 > 100 sq.in.= <u>D-H-W-240</u>	<u>Not Permitted</u>	<u>4</u>	<u>Not Permitted</u>	<u>W-240</u>
	<u>3</u>	<u>3^a</u>	<u>100 sq. in.</u>	<input type="checkbox"/> 100 sq.in. = D-H-180 > 100 sq.in.= <u>D-H-W-180</u>	<u>Not Permitted</u>	<u>3</u>	<u>Not Permitted</u>	<u>W-180</u>
Shaft, exit enclosures and exit passageway walls	2	1½	100 sq. in. ^{c,d}	<input type="checkbox"/> 100 sq.in. = D-H-90 > 100 sq.in.= D-H-T D-H-T-W-90	Not Permitted	2	Not Permitted	W-120

TYPE OF ASSEMBLY	REQUIRED WALL ASSEMBLY RATING (hours)	MINIMUM FIRE DOOR AND FIRE SHUTTER ASSEMBLY RATING (hours)	DOOR VISION PANEL SIZE ^b	FIRE RATED GLAZING MARKING DOOR VISION PANEL ^{e,d}	MINIMUM SIDELIGHT/TRANSOM ASSEMBLY RATING (hours)		FIRE-RATED GLAZING MARKING SIDELITE/TRANSOM PANEL	
					Fire protection	Fire resistance	Fire protection	Fire resistance
Fire barriers having a required fire-resistance rating of 1 hour: Enclosures for shafts, exit access stairways, exit access ramps, interior exit stairways, interior exit ramps and exit passageway walls	1	1	100 sq. in. ^{c,d}	<input type="checkbox"/> 100 sq.in. = D-H-60 <input type="checkbox"/> >100 sq.in. = D-H-T-60 or D-H-T-W-60	Not Permitted	1	Not Permitted	W-60
					Fire protection			
Other fire barriers	1	³ / ₄	Maximum size tested	D-H-NT-45		³ / ₄		D-H-NT-45
Fire partitions: Corridor walls	1	¹ / ₃ ^b	Maximum size tested	D-20		³ / ₄ ^b		D-H-OH-45
	0.5	¹ / ₃ ^b	Maximum size tested	D-20		¹ / ₃		D-H-OH-20
Other fire partitions	1	³ / ₄	Maximum size tested	D-H-45		³ / ₄		D-H-45
	0.5	¹ / ₃	Maximum size tested	D-H-20		¹ / ₃		D-H-20

(continued)

TABLE 716.5—continued
OPENING FIRE PROTECTION ASSEMBLIES, RATINGS AND MARKINGS

TYPE OF ASSEMBLY	REQUIRED WALL ASSEMBLY RATING (hours)	MINIMUM FIRE DOOR AND FIRE SHUTTER ASSEMBLY RATING (hours)	DOOR VISION PANEL SIZE ^b	FIRE RATED GLAZING MARKING DOOR VISION PANEL ^{e,d}	MINIMUM SIDELIGHT/TRANSOM ASSEMBLY RATING (hours)		FIRE-RATED GLAZING MARKING SIDELITE/TRANSOM PANEL		
					Fire protection	Fire resistance	Fire protection	Fire resistance	
Exterior walls	3	1½	100 sq. in. ^{e,b}	□100 sq.in. = D-H-90 >100 sq.in = D-H-W-90	Not Permitted	3	Not Permitted	W-180	
	2	1½	100 sq. in. ^{e,b}	□100 sq.in. = D-H-90 >100 sq.in.= D-H-W-90	Not Permitted	2	Not Permitted	W-120	
						Fire Protection			
	1	¾	Maximum size tested	D-H-45	¾		D-H-45		
Smoke barriers						Fire protection			
	1	1/3 ^b	Maximum size tested	D-20	¾		D-H-OH-45		

For SI: 1 square inch = 645.2 mm.

- a. Two doors, each with a fire protection rating of 1½ hours, installed on opposite sides of the same opening in a fire wall, shall be deemed equivalent in fire protection rating to one 3-hour fire door.
- b. For testing requirements, see Section 716.6.3.
- b.e. Fire-resistance-rated glazing tested to ASTM E 119 in accordance with Section 716.2 shall be permitted, in the maximum size tested.
- c.d. Except where the building is equipped throughout with an automatic sprinkler and the fire-rated glazing meets the criteria established in Section 716.5.5.
- d.e. Under the column heading “Fire-rated glazing marking door vision panel,” W refers to the fire-resistance rating of the glazing, not the frame.
- e. See Section 716.5.8.1.2.1.

Reason: The ICC Board established the ICC Code Technology Committee (CTC) as the venue to discuss contemporary code issues in a committee setting which provides the necessary time and flexibility to allow for full participation and input by any interested party. The code issues are assigned to the CTC by the ICC Board as “areas of study”. Information on the CTC, including: meeting agendas; minutes; reports; resource documents; presentations; and all other materials developed in conjunction with the CTC effort can be downloaded from the following website: <http://www.iccsafe.org/cs/CTC/Pages/default.aspx>. Since its inception in April/2005, the CTC has held twenty two meetings - all open to the public.

This proposed change is a result of the CTC’s investigation of the area of study entitled “Labeling of Fire Rated Glazing”. The scope of the activity is noted as:

Identify root causes of problems selecting, specifying, installing, and inspecting fire protective and fire resistive glazing and other assembly components including the frames. Propose identification requirements and other related code changes.

Table 716.5 was heavily modified for the 2012 edition of the International Building Code to serve as a reference summary of current code requirements, i.e., the items located in the table are specified by technical language found in the code. Based upon a review of the table as currently depicted in the 2012 IBC as compared to the current language of the IBC additional items require inclusion and some items require modification to reflect the current code as modified by other proposals during the last cycle.

There are no technical changes to current code requirements proposed, the changes are editorial.

A section was added to the table for "Horizontal Exits in Fire Walls" to provide for a summary of current glazing requirements for openings in those assemblies.

Note b, (formerly note c), has been relocated to the top of the column "Door Vision Panel Size" because the allowance for fire-resistance rated glazing in the maximum size tested applies in all cases depicted.

Specific reference is added to Note b for door vision panels in fire doors located in 3 and 4 hour fire walls because only fire-resistance rated glazing is permitted to be utilized, fire protection rated glazing is not permitted in any size. The appropriate marking requirements have been added as well in the next column, "Fire Rated Glazing Marking Door Vision Panel".

"D-H-T" or and "D-H-T-60 or" have been stricken from 2 hr "Shaft, exit enclosures and exit passageway walls" and from 1 hr "Fire barriers having a required fire-resistance rating of 1 hour." requirements since fire-protection rated glazing is limited to the 100 sq. in. size and only fire-resistance rated glazing can be utilized in larger proportions.

NT has been stricken in several locations as the requirement for marking glazing as "not tested" for a particular feature has been eliminated as a code consideration. Glazing is simply required to be marked for those attributes it has been tested and listed for.

Existing Note b is being deleted as no longer accurate or necessary for application of the table.

Note e is added to provide guidance on where the requirements for the horizontal exit in fire walls glazing requirements are located and to highlight that there is a dimension restriction in addition to the maximum size limitation.

Cost Impact: The code change proposal will not increase the cost of construction.

FS85-12

Public Hearing:	Committee:	AS	AM	D
	Assembly:	ASF	AMF	DF

716.5-FS-BALDASSARRA-CTC

FS86 – 12

Table 716.5, 716.5.8.1.2.1, 716.5.8.1.2.2

Proponent: Thomas S. Zaremba, Roetzel & Address, representing Glazing Industry Code Committee and Primary Fire Rated Glazing Manufacturers (tzaremba@ralaw.com)

Revise as follows:

**TABLE 716.5
OPENING FIRE PROTECTION ASSEMBLIES, RATINGS AND MARKINGS**

TYPE OF ASSEMBLY	REQUIRED WALL ASSEMBLY RATING (hours)	MINIMUM FIRE DOOR AND SHUTTER ASSEMBLY RATING (hours)	DOOR VISION PANEL SIZE	FIRE RATED GLAZING MARKING DOOR VISION PANEL ^e	MINIMUM SIDELIGHT! TRANSOM ASSEMBLY RATING (hours)		FIRE-RATED GLAZING MARKING SIDELITE/TRANSOM PANEL	
					Fire protection	Fire resistance	Fire protection	Fire resistance
Fire walls and fire barriers having a required fire-resistance rating greater than 1 hour	4	3	Not Permitted	Not Permitted	Not Permitted	4	Not Permitted	W-240
	3	3 ^a	Not Permitted	Not Permitted	Not Permitted	3	Not Permitted	W-180
	2	1½	400 sq. in. <u>Maximum size tested</u> ^c	≤100 sq.in. = D-H-90 >100 sq.in. = <u>or D-H-W-90</u>	Not Permitted	2	Not Permitted	W-120
	1½	1½	400 sq. in. <u>Maximum size tested</u> ^c	≤100 sq. in. = D-H-90 >100 sq. in. = <u>or D-H-W-90</u>	Not Permitted	1½	Not Permitted	W-90
Shaft, exit enclosures and exit passageway walls	2	1½	100 sq. in. ^{c,d}	≤100 sq. in. = D-H-90 >100 sq in. = D-H-T-or D-H-T-W-90	Not Permitted	2	Not Permitted	W-120

Fire barriers having a required fire-resistance rating of 1 hour: Enclosures for shafts, exit access stairways, exit access ramps, interior exit stairways, interior exit ramps and exit passageway walls	1	1	100 sq.in. ^{cd}	≤100 sq.in. = D-H-60 >100 sq.in. = D-H-T-60 or D-H-T-W-60	Not Permitted	1	Not Permitted	W-60
					Fire protection			
Other fire barriers	1	34	Maximum size tested	D-H-NT-45	34		D-H-NT-45	
Fire partitions: Corridor walls	1 0.5	13 ^b 13 ^b	Maximum size tested Maximum size tested	D-20 D-20	34 ^b 13		D-H-OH-45 D-H-OH-20	
Other fire partitions	1 0.5	34 13	Maximum size tested Maximum size tested	D-H-45 D-H-20	34 13		D-H-45 D-H-20	

**TABLE 716.5—continued
OPENING FIRE PROTECTION ASSEMBLIES, RATINGS AND MARKINGS**

TYPE OF ASSEMBLY	REQUIRED WALL ASSEMBLY RATING (hours)	MINIMUM FIRE DOOR AND FIRE SHUTTER ASSEMBLY RATING (hours)	DOOR VISION PANEL SIZE	FIRE RATED GLAZING MARKING DOOR VISION PANEL ^e	MINIMUM SIDELIGHT/TRANSOM ASSEMBLY RATING (hours)		FIRE-RATED GLAZING MARKING SIDELITE/TRANSOM PANEL		
					Fire protection	Fire resistance	Fire protection	Fire resistance	
Exterior walls	3	1½	400 sq. in. Maximum size tested _c	≤100 sq.in. = D-H-90 >100 sq.in. = or D-H-W-90	Not Permitted	3	Not Permitted	W-180	
	2	1½	400 sq. in. Maximum size tested _c	≤100 sq.in. = D-H-90 >100 sq.in. = or D-H-W-90	Not Permitted	2	Not Permitted	W-120	
						Fire Protection			
	1	¾	Maximum Size tested	D-H-45	¾		D-H-45		
Smoke barriers						Fire protection			
	1 ₁	1 ³ _b	Maximum Size tested Size Tested size tt	D-20	¾		D-H-OH-45		

For SI: 1 square inch = 645.2 mm

- a. Two doors, each with a fire protection rating of 1½ hours, installed on opposite sides of the same opening in a fire wall, shall be deemed equivalent in fire protection rating to one 3-hour fire door.
- b. For testing requirements, see Section 716.6.3.
- c. Fire-resistance-rated glazing tested to ASTM E 119 in accordance with Section 716.2 shall be permitted, in the maximum size tested.
- d. Except where the building is equipped throughout with an automatic sprinkler and the fire-rated glazing meets the criteria established in Section 716.5.5.
- e. Under the column heading "Fire-rated glazing marking door vision panel," W refers to the fire-resistance rating of the glazing, not the frame.

716.5.8.1.2.1 Horizontal exits. Fire-protection rated glazing shall be permitted as vision panels in 1½-hour fire protection rated, self-closing swinging fire door assemblies serving as horizontal exits in fire walls where limited to 100 square inches (0.065 m²) with no dimension exceeding 40 inches (0.3 m²).

716.5.8.1.2.2 Fire barriers. Fire-protection-rated glazing shall be permitted in fire doors having a 1½-hour fire protection rating intended for installation in fire barriers, where limited to 100 square inches (0.065 m²).

Reason: This proposal eliminates an inconsistency in the IBC and an inconsistency between the IBC and NFPA 80. In that regard, IBC section 716.5 says that "fire door assemblies and shutters shall be installed in accordance with ... NFPA 80." In turn, NFPA 80 provides that fire protection rated glazing may be used to the maximum sizes tested in 1½ hour fire protection rated doors in fire walls and fire barriers. In allowing fire protection rated glazing in the maximum sizes tested in these applications, NFPA 80 correctly recognizes that, since the doors in these applications are not fire-resistance or temperature rise rated, there is no reason to limit their use of fire protection rated glazing to 100 sq. in. If adopted, this proposal would reconcile these sections of the IBC and NFPA 80.

Cost Impact: The code change proposal will not increase the cost of construction.

FS86-12

Public Hearing:	Committee:	AS	AM	D
	Assembly:	ASF	AMF	DF

T716.5-FS-ZAREMBA

FS87 – 12

716.5.2

Proponent: William E. Koffel, P.E., Koffel Associates, Inc., representing Won-Door Corporation (wkoffel@koffel.com)

Revise as follows:

716.5.2 Other types of assemblies. *Fire door* assemblies with other types of doors, including swinging elevator doors, horizontal sliding fire door assemblies, and fire shutter assemblies, bottom and side-hinged chute intake doors, and top-hinged chute discharge doors, shall be tested in accordance with NFPA 252 or UL 10B. The pressure in the furnace shall be maintained as nearly equal to the atmospheric pressure as possible. Once established, the pressure shall be maintained during the entire test period.

Reason: Paragraph 716.5.1 applies to side-hinged or pivoted swinging doors and Paragraph 716.5.2 applies to other types of fire doors. However, the list of other types of fire doors is not all inclusive which has led some to wonder how the provisions apply to fire protection rated horizontal sliding doors. Therefore, the phrase “horizontal sliding doors” has been proposed to be added to the list.

Alternatively, if concern exists that the list may still be incomplete, all the text between the first and second comma could be deleted, thereby deleting the list from the Code and indicating that Paragraph 716.5.2 applies to all doors other than those covered by Paragraph 716.5.1.

Cost Impact: None

FS87-12

Public Hearing:	Committee:	AS	AM	D
	Assembly:	ASF	AMF	DF

716.5.2-FS-KOFFEL

FS88 – 12

716.5.3.1

Proponent: Carl Baldassarra, P.E., FSFPE, Chair, ICC Code Technology Committee

Revise as follows:

716.5.3.1 Smoke and draft control. *Fire door* assemblies shall also meet the requirements for a smoke and draft control door assembly tested in accordance with UL 1784. The air leakage rate of the door assembly shall not exceed 3.0 cubic feet per minute per square foot ($0.01524 \text{ m}^3/\text{s} \cdot \text{m}^2$) of door opening at 0.10 inch (24.9 Pa) of water for both the ambient temperature and elevated temperature tests. Louvers shall be prohibited. Installation of smoke doors shall be in accordance with NFPA 105.

Exception: Where enclosed elevator lobbies are not required by Section 713.14.1, elevator hoistway doors opening into a corridor are not required to meet the requirements for a smoke and draft control door assembly.

Reason: The ICC Executive Board directed the Code Technology Committee (CTC) to study the issue of elevator lobby separations in November 2010 due to the number of code change proposals submitted addressing this issue over a number of code change cycles. The Code Technology Committee formed a study group on the elevator lobby separation issue in December 2010. Note that this subject had been previously addressed by CABO/BCMC in 1986 with a similar conclusion. The code change proposals submitted are the result of the CTC's study of the issue. Note that the scope of the activity was as follows:

Scope

- Review the need for elevator lobbies, with emphasis on building use, building and hoistway height, active and passive fire protection features associated with the aforementioned.
- Review the differences and specific needs when dealing with elevator lobbies of traditional-use elevators, fire service elevators, and occupant evacuation elevators.
- Review related code provisions, such as egress from and through elevator lobbies.
- Review the appropriate use of alternatives including pressurization of hoistways, additional doors, roll-down style barriers, and gasketing systems.
- Review with members of elevator industry to scope the requirements of applicable elevator reference standards as it deals with elevator lobby design, use and construction.
- Review design and construction requirements for elevator lobbies, including but not limited to dimensions, location and separation.
- Review applicable code change history, technical studies and loss statistics as part of this review.

Based upon the extensive nature of this area of study, 5 Task Groups were formed during the process to provide in-depth review and to manage the number of issues. These task groups developed a number of proposals that were coordinated throughout the process.

More information on this CTC area of study can be found at the following link.
<http://www.iccsafe.org/cs/CTC/Pages/ElevatorLobbies.aspx>

This proposal is intended to clarify that when an enclosed elevator lobby is not required in accordance with Section 713.14.1 that smoke and draft protection is not required when the hoistway opens into a rated corridor. See figure below. Section 713.14.1 is based upon number of stories and not the fact that such elevators open onto a rated corridor so it is not entirely clear how the code is currently written that this was the intent. The following are the sections that are relevant to this issue and which demonstrate how such confusion could occur. The lobby provisions are independent from the corridor provisions.

Note that this proposal is one of several proposals submitted by the CTC Elevator Lobby study group. This particular proposal will be correlated as necessary. For instance if the elevator lobby provisions are moved to chapter 30 then the referenced section will be appropriately revised. See discussion on CTC elevator lobby proposal coordination in code change FS##-12

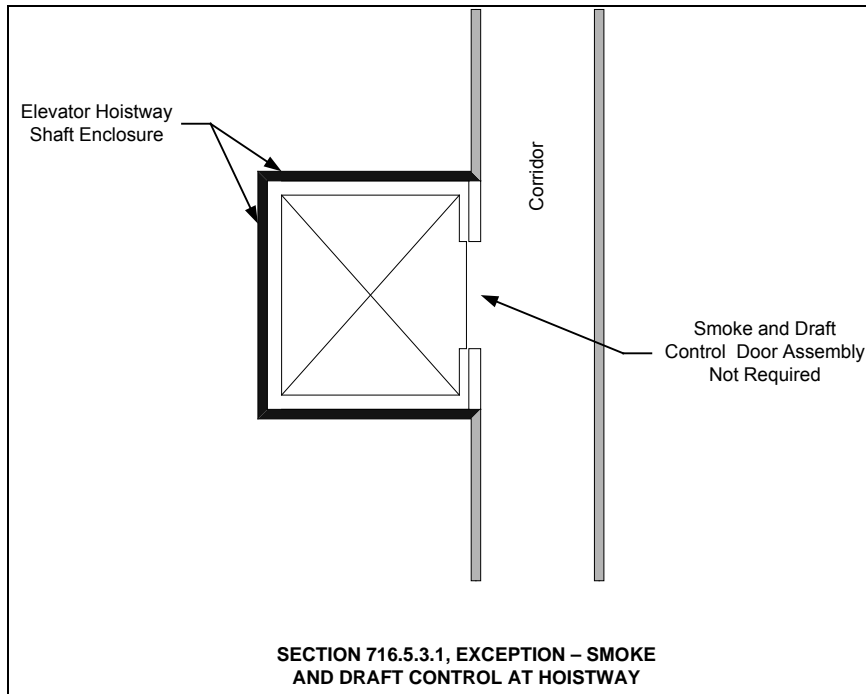

713.14 Elevator, dumbwaiter and other hoistways. Elevator, dumbwaiter and other hoistway enclosures shall be constructed in accordance with Section 713 and Chapter 30.

713.14.1 Elevator lobby. An enclosed elevator lobby shall be provided at each floor where an elevator shaft enclosure connects more than three *stories*. The lobby enclosure shall separate the elevator shaft enclosure doors from each floor by *fire partitions*. In addition to the requirements in Section 708 for *fire partitions*, doors protecting openings in the elevator lobby enclosure walls shall also comply with Section 716.5.3 as required for *corridor* walls and penetrations of the elevator lobby enclosure by ducts and air transfer openings shall be protected as required for *corridors* in accordance with Section 717.5.4.1. Elevator lobbies shall have at least one *means of egress* complying with Chapter 10 and other provisions within this code.

Exceptions:

1. Enclosed elevator lobbies are not required at the level(s) of *exit discharge*, provided the level(s) of *exit discharge* is equipped with an *automatic sprinkler system* in accordance with Section 903.3.1.1.
2. Elevators not required to be located in a shaft in accordance with Section 712.1 are not required to have enclosed elevator lobbies.
3. Enclosed elevator lobbies are not required where additional doors are provided at the hoistway opening in accordance with Section 3002.6. Such doors shall comply with the smoke and draft control door assembly requirements in Section 716.5.3.1 when tested in accordance with UL 1784 without an artificial bottom seal.
4. Enclosed elevator lobbies are not required where the building is protected by an *automatic sprinkler system* installed in accordance with Section 903.3.1.1 or 903.3.1.2. This exception shall not apply to the following:
 - 4.1. Group I-2 occupancies;
 - 4.2. Group I-3 occupancies; and
 - 4.3. Elevators serving floor levels over 75 feet above the lowest level of fire department vehicle access in high-rise buildings.
5. Smoke partitions shall be permitted in lieu of *fire partitions* to separate the elevator lobby at each floor where the building is equipped throughout with an *automatic sprinkler system* installed in accordance with Section 903.3.1.1 or 903.3.1.2. In addition to the requirements in Section 710 for smoke partitions, doors protecting openings in the smoke partitions shall also comply with Sections 710.5.2.2, 710.5.2.3, and 716.5.9 and duct penetrations of the smoke partitions shall be protected as required for *corridors* in accordance with Section 717.5.4.1.
6. Enclosed elevator lobbies are not required where the elevator hoistway is pressurized in accordance with Section 909.21.
7. Enclosed elevator lobbies are not required where the elevator serves only *open parking garages* in accordance with Section 406.3.

713.14.1.1 Areas of refuge. Areas of refuge shall be provided as required in Section 1007.

SECTION 1018 CORRIDORS

1018.1 Construction. *Corridors* shall be fire-resistance rated in accordance with Table 1018.1. The *corridor* walls required to be fire-resistance rated shall comply with Section 709 for *fire partitions*.

Exceptions:

1. A *fire-resistance rating* is not required for *corridors* in an occupancy in Group E where each room that is used for instruction has at least one door opening directly to the exterior and rooms for assembly purposes have at least one-half of the required *means of egress* doors opening directly to the exterior. Exterior doors specified in this exception are required to be at ground level.
2. A *fire-resistance rating* is not required for *corridors* contained within a dwelling or sleeping unit in an occupancy in Group R.
3. A *fire-resistance rating* is not required for *corridors* in *open parking garages*.
4. A *fire-resistance rating* is not required for *corridors* in an occupancy in Group B which is a space requiring only a single *means of egress* complying with Section 1015.1.
5. Corridors adjacent to the exterior walls of buildings shall be permitted to have unprotected openings on unrated exterior wall where unrated walls are permitted by Table 602 and unprotected openings are permitted by Table 705.8.

SECTION 708 FIRE PARTITIONS

708.1 General. The following wall assemblies shall comply with this section.

1. Walls separating *dwelling units* in the same building as required by Section 420.2.
2. Walls separating *sleeping units* in the same building as required by Section 420.2.
3. Walls separating tenant spaces in *covered mall buildings* as required by Section 402.7.2.
4. Corridor walls as required by Section 1018.1.
5. Elevator lobby separation as required by Section 713.14.1.

708.2 Materials. The walls shall be of materials permitted by the building type of construction.

708.3 Fire-resistance rating. Fire partitions shall have a *fire-resistance rating* of not less than 1 hour.

Exceptions:

1. Corridor walls permitted to have a $\frac{1}{2}$ hour *fire-resistance rating* by Table 1018.1.
2. *Dwelling unit* and *sleeping unit* separations in buildings of Type IIB, IIIB and VB construction shall have *fire-resistance ratings* of not less than $\frac{1}{2}$ hour in buildings equipped throughout with an *automatic sprinkler system* in accordance with Section 903.3.1.1.

708.6 Openings. Openings in a *fire partition* shall be protected in accordance with Section 716.

SECTION 710 SMOKE PARTITIONS

710.1 General. Smoke partitions installed as required elsewhere in the code shall comply with this section.

710.5 Openings. Openings in smoke partitions shall comply with Sections 710.5.1 and 710.5.2.

710.5.1 Windows. Windows in smoke partitions shall be sealed to resist the free passage of smoke or be automatic-closing upon detection of smoke.

710.5.2 Doors. Doors in smoke partitions shall comply with Sections 710.5.2.1 through 710.5.2.3.

710.5.2.1 Louvers. Doors in smoke partitions shall not include louvers.

710.5.2.2 Smoke and draft control doors. Where required elsewhere in the code, doors in smoke partitions shall meet the requirements for a smoke and draft control door assembly tested in accordance with UL 1784. The air leakage rate of the door assembly shall not exceed 3.0 cubic feet per minute per square foot ($0.015424 \text{ m}^3/(\text{s} \cdot \text{m}^2)$) of door opening at 0.10 inch (24.9 Pa) of water for both the ambient temperature test and the elevated temperature exposure test. Installation of smoke doors shall be in accordance with NFPA 105.

SECTION 716 OPENING PROTECTIVES

716.1 General. Opening protectives required by other sections of this code shall comply with the provisions of this section.

716.5 Fire door and shutter assemblies. Approved *fire door* and fire shutter assemblies shall be constructed of any material or assembly of component materials that conforms to the test requirements of Section 716.5.1, 716.5.2 or 716.5.3 and the *fire protection rating* indicated in Table 716.5. *Fire door* frames with transom lights, sidelights or both shall be permitted in accordance

with Section 716.5.6. *Fire door* assemblies and shutters shall be installed in accordance with the provisions of this section and NFPA 80.

Exceptions:

1. Labeled protective assemblies that conform to the requirements of this section or UL 10A, UL 14B and UL 14C for tin-clad *fire door* assemblies.
2. Floor *fire door* assemblies in accordance with Section 711.8.

**TABLE 716.5
OPENING FIRE PROTECTION ASSEMBLIES, RATINGS AND MARKINGS**

TYPE OF ASSEMBLY	REQUIRED WALL ASSEMBLY RATING (hours)	MINIMUM FIRE DOOR AND FIRE SHUTTER ASSEMBLY RATING (hours)	DOOR VISION PANEL SIZE	FIRE RATED GLAZING MARKING DOOR VISION PANEL ^e	MINIMUM SIDELIGHT/TRANSOM ASSEMBLY RATING (hours)	FIRE RATED GLAZING MARKING SIDELITE/TRANSOM PANEL
Fire partitions: Corridor walls	0.5	1/3 ^b	Maximum size tested	D-20	1/3	D-H- OH-20

716.5.3 Door assemblies in corridors and smoke barriers. *Fire door* assemblies required to have a minimum *fire protection rating* of 20 minutes where located in *corridor* walls or *smoke barrier* walls having a *fire-resistance rating* in accordance with Table 716.5 shall be tested in accordance with NFPA 252 or UL 10C without the hose stream test.

Exceptions:

1. Viewports that require a hole not larger than 1 inch (25 mm) in diameter through the door, have at least a 0.25-inch-thick (6.4 mm) glass disc and the holder is of metal that will not melt out where subject to temperatures of 1,700°F (927°C).
2. *Corridor* door assemblies in occupancies of Group I-2 shall be in accordance with Section 407.3.1.
3. Unprotected openings shall be permitted for *corridors* in multitheater complexes where each motion picture auditorium has at least one-half of its required *exit* or *exit access doorways* opening directly to the exterior or into an *exit* passageway.
4. Horizontal sliding doors in *smoke barriers* that comply with Sections 408.3 and 408.8.4 in occupancies in Group I-3.

Cost Impact: The code change proposal will not increase the cost of construction.

FS88-12

Public Hearing: Committee: AS AM D
 Assembly: ASF AMF DF

716.5.3.1-FS-BALDASSARRA-CTC

FS89 – 12

716.5.3.2, 716.5.3.2.1 (New), 716.6.7.4 (New)

Proponent: Robert J Davidson, Davidson Code Concepts, LLC, representing SaftiFirst a Division of O'Keefes, Inc. (rjd@davidsoncodeconcepts.com)

Revise as follows:

716.5.3 Door assemblies in corridors and smoke barriers. *Fire door* assemblies required to have a minimum *fire protection rating* of 20 minutes where located in *corridor walls* or *smoke barrier walls* having a *fire-resistance rating* in accordance with Table 716.5 shall be tested in accordance with NFPA 252 or UL 10C without the hose stream test.

Exceptions: (No change to current text)

716.5.3.2 Glazing in door assemblies. In a 20-minute *fire door assembly*, the glazing material in the door itself shall have a minimum fire-protection-rated glazing of 20 minutes and shall be exempt from the hose stream test. Glazing material in any other part of the door assembly, including transom lights and sidelights, shall be tested in accordance with NFPA 257 or UL 9, including the hose stream test, in accordance with Section 716.6, subject to the limitations in Section 716.5.3.2.1.

716.5.3.2.1 Glazing in sidelites. The use of fire protection rated glazing in sidelites shall be limited to a minimum of 44 inches above the finished floor surface.

716.6.7 Interior fire window assemblies. Fire-protection- rated glazing used in *fire window assemblies* located in *fire partitions* and *fire barriers* shall be limited to use in assemblies with a maximum *fire-resistance rating* of 1 hour in accordance with this section.

716.6.7.4 Interior fire windows in fire-resistant rated corridors and exit passageways. Fire protection-rated glazing in fire windows tested to NFPA 257 used in fire-resistant rated corridors and exit passageways shall be limited to applications where the bottom edge of the window frame is a minimum of 44-inches above the finished floor surface. The bottom edge height of fire resistance rated glazing tested as an assembly to ASTM E119 or UL 263 and rated a minimum of 1-hour shall not be limited.

Reason: The purpose of this proposal is to provide for protection of specific egress paths against radiant heat exposure that can occur through the use of fire protection rated glazing. Building codes in other countries such as New Zealand and the United Kingdom have taken this exposure problem into account in the application of their requirements with height above egress path limitations of 1100 mm (43.3 inches) and up to 2 M (6.6 feet).

Fire protection rated glazing materials do not protect against radiant heat. The unrestricted use of these materials in exit corridors in the large sizes for which they have been tested and listed threaten the life safety of building occupants attempting to exit past them in a fire as well as firefighters using the same protected path for rescue and firefighting. By restricting the use of these materials to above 44" from the floor along specific egress paths, occupants and firefighters can crawl below the level of the fire windows, and combustibles piled on the floor are not as likely to pose a threat to windows installed at this height.

This proposal addresses the radiant heat issue by providing for a height limitation in the application of fire protection rated glazing in sidelights with proposed Section 716.5.3.2.1 and the use of fire protection rated glazing in specific egress paths in proposed Section 716.6.7.2.

The recognition of this issue is not restricted to overseas; NFPA 80 provides background information and recommends that the consideration be given to the issue.

NFPA 80-2010

4.4.5* *Glazing material shall be permitted in fire doors having the fire protection ratings shown in Table 4.4.5 when tested in accordance with NFPA 252, Standard Methods of Fire Tests of Door Assemblies, and shall be limited in size and area in accordance with Table 4.4.5.*

A.4.4.5 *Doors containing fire resistance-rated glazing materials fabricated and tested as door assemblies in accordance with NFPA 252, Standard Methods of Fire Tests of Door Assemblies, to determine a fire protection rating should be regulated by this standard as a fire assembly and not as a glazing material permitted in fire door assemblies as prescribed in Section 4.4.*

Regarding Table 4.4.5, footnote c, consideration should be given to limiting fire protection glazing size in non-temperature rise doors where 60- and 90-minute fire protection is required due to radiant heat hazards. See Annex I.

If the limited amount of glazing in a fire door presents a risk, fire windows along a corridor or exit passageway would be a greater risk. Within NFPA 80 Appendix I the opening paragraph states:

I.1 Background. Fire windows were originally designed for protecting openings in exterior walls. In such applications, radiant heat transfer was not a significant consideration, since the main function of fire windows was to contain the flames within the building. However, where fire windows are used in interior partitions, users of this standard might need to consider radiant heat transfer during fire. Exiting through corridors and past fire windows could be compromised, and combustible materials on the unexposed side of fire windows could be ignited. The information that follows is a guide to the evaluation of radiant heat transfer through fire windows.

The third paragraph of NFPA 80 Appendix I states:

Test Method. Because the present fire test standard, NFPA 257, does not require measuring and reporting temperature rise on the unexposed face of the glazing material or radiant heat transmission, glazing products tested to this standard have not been required to retard heat transfer. However, these data are required in many European fire test standards. [2] As a result, European building codes place limitations on the use of glazing in fire-resistant partitions inside buildings and require the use of insulating glazing in means of egress as well as where combustibles could be in close proximity

This code change at the same time permits use in larger sizes of products that meet fire resistance radiant heat and temperature rise limits of ASTM E119, as those products do not transmit dangerous levels of radiant heat.

Fire test data show that at 45-minutes, these products transmit in excess of 20 kW/m², at 20 minutes of fire exposure, these materials transmit in excess of 10 kW/m², and at 10 minutes of fire exposure, transmit 5 kW/m². <http://vimeo.com/13218481> See below, Chart Cumulative Radiant Heat Energy Data Chart, prepared by the test sponsor of the test cited above. The Society of Fire Protection Engineers Fire Protection Engineering Handbook identifies a fairly obvious tolerance limit for exposure to radiant heat of 2.5 kW/m² due to unbearable pain. (See SFPE Handbook of Fire Protection Engineering, 2nd edition, page 2-114).

Radiant Heat Flux: Comparison

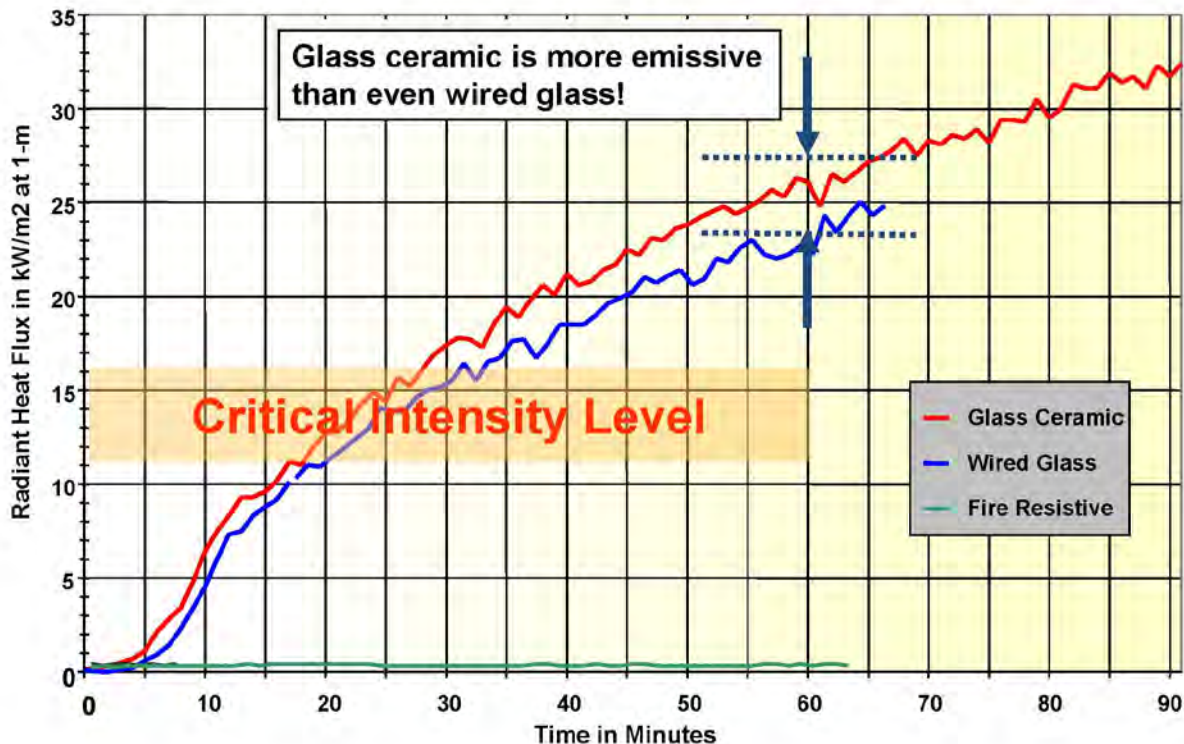

Also included as further support of this code change are two test reports from the Coast Guard testing of (1) Ceramic (FireLite) in steel bulkheads (Report No. CG-D-37-95), and (2) wired glass in steel bulkheads (Report No. CG-D-38-95). Temperature rise and radiant heat flux measurements were recorded. The tests were intended to measure radiant heat flux and surface temperature performance at 60 minutes.

The tests can be summarized as follows:

Wired Glass Test

The test of the wired glass panels resulted in glazing failure prior to 60-minutes, so radiant heat and temperature rise were only recorded up to the time of the wired glass failure.

Test 1

- Heat flux at end of test (41:24 minutes) - 71 kW/m sq.
- Surface temperature - wired glass temperature - 730 degrees C; steel frame - 540 degrees C

Test 2

- Heat flux at end of test (37:46 minutes) - 48 kW/m sq.
- Surface temperature - wired glass temperature - 730 degrees C; steel frame - 550 degrees C

Test 3

- Heat flux at end of test (48:30 minutes) - 57 kW/m sq.
- Surface temperature - wired glass temperature - 760 degrees C; steel frame - 585 degrees C

Conclusion on page 8 - As the window panes began to reach their melting point and flow out of the test frame, the recorded heat flux levels showed obvious increases. In all three tests, the recorded heat flux increased approximately 5-7 kW/m sq. until the wire glass fell out of the test frame and the test was terminated.

Ceramic (FireLite) Test

Test 1

- Heat flux at end of test (60:00 minutes) - 75 kW/m sq.
- Surface temperature - ceramic glass temperature - 800 degrees C; steel frame - 600 degrees C

Test 2

- Heat flux at end of test (60:00 minutes) - 69 kW/m sq.
- Surface temperature - ceramic glass temperature - 800 degrees C; steel frame - 600 degrees C

Test 3

- Heat flux at end of test (60:00 minutes) - 73 kW/m sq.
- Surface temperature - ceramic glass temperature - 800 degrees C; steel frame - 600 degrees C

According to these test reports, the surface temperature is significantly higher on the glazing than it is on the steel frame. Also, the report notes that the radiant heat measurements taken that included the "cooler steel frame" were several percentages lower than the view that included just the glazing. (see Ceramic test report (Report No. CG-D-37-95), page 6.)

Limitations on area uses of fire protection-rated glazing products is long overdue. In Europe, code regulators have recognized the need for restricting use of fire protection-rated glazing materials based on radiant heat hazards, particularly their use in egress paths. Reasonable limits protecting life safety are achieved by limiting the height of windows in exit corridors, permitting building occupants safe egress. The restriction on use in other fire barriers and fire partitions reduces the possibility of fire spread due to auto-ignition, which test data show can occur well before the 45-minute fire exposure to which fire protection-rated glazing products have been tested.

Bibliography

1. Test Report, Fire Performance of Three Wired Glazed Window Assemblies, Report No. CG-D-38-95
<http://www.dtic.mil/cgi-bin/GetTRDoc?AD=ADA302226>
2. Test Report, Fire Performance Evaluation of Three A-O Glazed Window Assemblies, Report No. CG-D-37-95
<http://www.dtic.mil/cgi-bin/GetTRDoc?AD=ADA302316>
3. New Zealand Compliance Document for New Zealand Building Code Clauses C1, C2, C3, C4 Fire Safety
<http://www.dbh.govt.nz/UserFiles/File/Publications/Building/Compliance-documents/C-fire-safety-1st-edition-amendment-9.pdf>
4. United Kingdom Building regulations Fire Safety, Volume 2 – Buildings Other than Dwellinghouses
http://www.planningportal.gov.uk/uploads/br/BR_App_Doc_B_v2.pdf
5. NFPA 80-2010 "Standard for Fire Doors and Other Opening Protectives"
<http://www.nfpa.org/aboutthecodes/AboutTheCodes.asp?DocNum=80>

Cost Impact: This code change will not increase construction costs, as fire protection-rated glazing materials are still permitted, and the cost of fire resistance products permitted for larger applications and next to the floor is now comparable to safety rated fire protection products that pass hose stream testing.

FS89-12

Public Hearing:	Committee:	AS	AM	D
	Assembly:	ASF	AMF	DF

716.6.7.3 (NEW)-FS-DAVIDSON

FS90 – 12

716.5.3.2, 716.5.4, 716.5.4.1 (New)

Proponent: Robert J Davidson, Davidson Code Concepts, LLC, representing SaftiFirst a Division of O'Keeffes, Inc. (rjd@davidsoncodeconcepts.com)

Revise as follows:

716.5.3.2 Glazing in door assemblies. In a 20-minute fire door assembly, the glazing material ~~in the door itself~~ shall have a minimum fire-protection-rated glazing of 20 minutes and shall be exempt from the hose stream test. ~~Glazing material in any other part of the door assembly, including transom lights and sidelights, shall be tested in accordance with NFPA 257 or UL 9, including the hose stream test, in accordance with Section 716.6.~~

716.5.4 Door assemblies in other fire partitions. Fire door assemblies required to have a minimum fire protection rating of 20 minutes where located in other fire partitions having a fire-resistance rating of 0.5 hour in accordance with Table 716.5 shall be tested in accordance with NFPA 252, UL 10B or UL 10C ~~with~~ without the hose stream test.

716.5.4.1 Glazing in door assemblies. In a 20-minute fire door assembly, the glazing material shall have a minimum fire-protection-rated glazing of 20 minutes and shall be exempt from the hose stream test.

Reason: This code change proposal is intended to eliminate an unnecessary hose stream test requirement, provide for increased consistency in the code requirements and increased consistency with the referenced standards for fire door assemblies.

The first change is at Section 716.5.3.2. A 20 minute fire door in a corridor or smoke barrier does not require a hose stream test. Section 716.5.3.2 does not require a hose stream test for the glazing in the door itself, but it then requires the hose stream test for the glazing located anywhere else in the fire door assembly. This does not make sense, it is one assembly and it should be consistently tested as an assembly to the same standard. The hose stream test is either needed or it is not.

The next proposed change is to eliminate the hose stream test requirement for 20 minute doors in other fire partitions. Since we have eliminated the requirement for 20 minute doors in corridors (the means of egress protection) and smoke barriers (patient protection), why would we then require the hose test in other cases of 20 minute doors located in fire partitions that only have a 0.5 hour rating? This lacks consistency.

The final proposed change is to add glazing requirement language for the "other fire partition" door assemblies, matching the language proposed for the doors in corridors and smoke barriers.

It should be noted that NFPA 80 "Standard for Fire Doors and Other Opening Protectives" 2010 edition provides for the door and the glazing to be tested as an assembly in accordance with NFPA 252 which is consistent with Section 716.5.3 and points out the difference between glazing tested separately as fire protection rated glazing and then installed in a fire door as compared to glazing tested as part of the door assembly. (See A.4.4.5)

NFPA 80-2010

4.4.4* Fire protection glazing not exceeding 100 in.2 (0.065m2) shall be permitted in fire doors having a 3-hour fire protection rating or in fire doors having a 1 1/2-hour fire protection rating for use in severe exterior fire exposure locations where the fire protection glazing has been tested for the desired rating period with no through-openings in accordance with NFPA 252, Standard Methods of Fire Tests of Door Assemblies.

4.4.5* Glazing material shall be permitted in fire doors having the fire protection ratings shown in Table 4.4.5 when tested in accordance with NFPA 252, Standard Methods of Fire Tests of Door Assemblies, and shall be limited in size and area in accordance with Table 4.4.5.

A.4.4.5 Doors containing fire resistance-rated glazing materials fabricated and tested as door assemblies in accordance with NFPA 252, Standard Methods of Fire Tests of Door Assemblies, to determine a fire protection rating should be regulated by this standard as a fire assembly and not as a glazing material permitted in fire door assemblies as prescribed in Section 4.4.

The NFPA 252 "Standard Methods of Fire Tests of Door Assemblies" 2008 edition provides for the elimination of the hose stream test at the option of the sponsor, recognizing that there are codes that allow for elimination of the hose stream test and it goes on to explain that the elimination is based upon the field application.

NFPA 252-2008

6.2 Hose Stream Test.

6.2.1* *Within the 2 minutes immediately following the fire test, the fire-exposed side of the fire door assembly shall be subjected to the impact, erosion, and cooling effects of a standard hose stream, unless otherwise permitted by 6.2.2.*

6.2.2* *For 20-minute fire protection-rated fire door assemblies, at the option of the test sponsor, the hose stream test shall not be required to be performed.*

A.6.2.2 *The elimination of the hose stream test for some 20-minute-rated assemblies is based on their field application.*

Since NFPA 80 identifies that the glazing be tested as part of the fire door assembly in accordance with NFPA 252, and NFPA 252 recognizes the elimination of the hose stream test with no special requirement that the glazing be subjected to the hose stream test anyway, this proposal will provide for better harmony between the IBC and the referenced standards.

Cost Impact: The code change proposal will reduce the cost of construction.

FS90-12

Public Hearing:	Committee:	AS	AM	D
	Assembly:	ASF	AMF	DF

716.5.3.2-FS-DAVIDSON

FS91 – 12

716.5.5.1

Proponent: Thomas S. Zaremba, Roetzel & Andress, representing Glazing Industry Code Committee and Primary Fire Rated Glazing Manufacturers (tzaremba@ralaw.com)

Revise as follows:

716.5.5.1 Glazing in doors. Fire-protection-rated glazing in excess of 100 square inches (0.065 m²) is not permitted. Fire-resistance-rated glazing in excess of 100 square inches (0.065 m²) shall be permitted in fire doors, assemblies when tested as components of the door assemblies, and not as glass lights, and shall have a maximum transmitted temperature rise of 450o F (250o C) in accordance with Section 716.5.5. Fire doors using listed fire-resistance-rated glazing shall have a maximum transmitted temperature rise in accordance with Section 716.5.5 when tested in accordance NFPA 252, UL 10B or UL 10C.

Reason: This proposal is not intended to change the underlying requirements of section 716.5.5.1. It is intended to provide uniformity for testing fire-resistance-rated glazing when it is used in temperature rise fire doors.

When glazing in temperature rise fire doors exceeds 100 sq. in., it must be fire-resistance-rated glazing. An issue arises as to the sequence of testing when fire-resistance-rated glazing is used in a fire door because fire-resistance-rated glazing is tested to ASTM E119 and the fire door is tested to NFPA 252. Working closely with UL, this code change proposal was developed to answer the question as to how to test a fire door when it uses fire-resistance-rated glazing. In that regard, the proposal would require the glazing to be tested first, and, if it meets the ASTM E119 acceptance criteria, it is listed as a fire-resistance-rated glazing. That "listed fire-resistance rated glazing" is then installed in a fire door and tested in accordance with NFPA 252, the fire door test, including tests for the maximum transmitted temperature rise requirements of Section 716.5.5.

If adopted, this proposal will provide uniformity for testing ASTM E119 fire-resistance-rated glazing when used in NFPA 252 tested fire doors.

Cost Impact: The code change proposal will not increase the cost of construction.

FS91-12

Public Hearing:	Committee:	AS	AM	D
	Assembly:	ASF	AMF	DF

716.5.5.1-FS-ZAREMBA

FS92 – 12
716.5.7.1.1

Proponent: Bob Eugene, representing Underwriters Laboratories (Robert.Eugene@ul.com)

Revise as follows:

716.5.7.1.1 Light kits, louvers and components. Listed light kits and louvers and their required preparations shall be considered as part of the labeled door where such installations are done under the listing program of the third-party agency. ~~Where tested for such use, Fire doors and door assemblies shall be permitted to consist of components, including glazing, vision light kits and hardware that are listed and labeled, listed or classified for such use by different third-party agencies.~~

Reason: This proposal clarifies that the evidence a combination of components have been tested for such use is listing and labeling.

Cost Impact: None

FS92-12

Public Hearing:	Committee:	AS	AM	D
	Assembly:	ASF	AMF	DF

716.5.7.1.1-FS-EUGENE

FS93 – 12
716.5.7.5 (New)

Proponent: William E. Koffel, P.E., Koffel Associates, Inc., representing Won-Door Corporation
(wkoffel@koffel.com)

Revise as follows:

716.5.7.5 Fire door operator labeling requirements. Fire door operators for horizontal sliding doors shall be labeled and listed for use with the assembly

Reason: Section 716.5 requires fire door assemblies to be installed in accordance with NFPA 80. NFPA 80 requires fire door operators to be listed for use with the door. As such, the proposed new text is already required by NFPA 80. However, it can easily be overlooked or confusion may occur as to whether this specific requirement in NFPA 80 applies since Section 716.5.7 requires specific components to be labeled but does not include the operator for horizontal sliding doors.

Cost Impact: None

FS93-12

Public Hearing:	Committee:	AS	AM	D
	Assembly:	ASF	AMF	DF

716.5.7.5 (NEW)-KOFFEL

FS94 – 12

716.5.8, 716.5.8.1, 716.5.8.1.2.1, 716.5.8.3

Proponent: Bob Eugene, representing Underwriters Laboratories (Robert.Eugene@ul.com)

Revise as follows:

716.5.8 Glazing material. Fire-protection-rated glazing conforming to the opening protective requirements in Section 716.5 shall be permitted in *fire door* assemblies.

716.5.8.1 Size limitations. Fire-resistance-rated glazing shall comply with the size limitations in Section 716.5.8.1.1. Fire-protection-rated glazing shall comply with the size limitations of NFPA 80, except as provided in Sections ~~716.5.8.1.1 and~~ 716.5.8.1.2.

716.5.8.1.1 Fire-resistance-rated glazing in door assemblies in fire walls and fire barriers rated greater than 1 hour. Fire-resistance-rated glazing tested to ASTM E 119 or UL 263 and NFPA 252, UL 10B or UL 10C shall be permitted in *fire door assemblies* located in *fire walls* and in *fire barriers* in accordance with Table 716.5 to the maximum size tested in accordance with their listings.

716.5.8.1.2 Fire-protection-rated glazing in door assemblies in fire walls and fire barriers rated greater than 1 hour. Fire-protection-rated glazing shall be prohibited in *fire walls* and *fire barriers* except as provided in Sections 716.5.8.1.2.1 and 716.5.8.1.2.2.

716.5.8.1.2.1 Horizontal exits. Fire-protection-rated glazing shall be permitted as vision panels in *self-closing* swinging *fire door* assemblies serving as horizontal exits in *fire walls* where limited to 100 square inches (0.065 m²) with no dimension exceeding 10 inches (0.3 m).

716.5.8.1.2.2 Fire barriers. Fire-protection-rated glazing shall be permitted in *fire doors* having a 1-1/2-hour *fire protection rating* intended for installation in *fire barriers*, where limited to 100 square inches (0.065 m²).

716.5.8.2 Elevator, stairway and ramp protectives. Approved fire-protection-rated glazing used in *fire door* assemblies in elevator, stairways and ramps enclosures shall be so located as to furnish clear vision of the passageway or approach to the elevator, stairway or ramp.

716.5.8.3 Labeling. Fire-protection-rated glazing shall bear a label or other identification showing the name of the manufacturer, the test standard and information required in Section ~~716.5.8.3.4~~ Table 716.3 that shall be issued by an *approved agency* and shall be permanently identified on the glazing.

Reason: The charging language of Section 716.5.8 references fire-protection-rated glazing. The sub sections which follow detail requirements for both fire-protection-rated glazing and fire-resistance-rated glazing. The proposed changes to Section 716.5.8 editorially correct this along with several other typographical errors. No technical changes are being introduced.

Cost Impact: None

FS94-12

Public Hearing:	Committee:	AS	AM	D
	Assembly:	ASF	AMF	DF

716.5.8-FS-EUGENE

FS95 – 12

716.5.8.4, 716.6.3

Proponent: Carl Baldassarra, P.E., FSFPE, Chair, ICC Code Technology Committee

Revise as follows:

716.5.8.4 Safety glazing. Fire-protection-rated glazing installed in *fire doors assemblies* in areas subject to human impact in hazardous locations shall also comply with the safety glazing requirements of Chapter 24 where applicable.

716.6.3 Safety glazing. Fire-protection-rated glazing installed in *fire window assemblies* in areas subject to human impact in hazardous locations shall also comply with the safety glazing requirements of Chapter 24 where applicable.

Reason: The ICC Board established the ICC Code Technology Committee (CTC) as the venue to discuss contemporary code issues in a committee setting which provides the necessary time and flexibility to allow for full participation and input by any interested party. The code issues are assigned to the CTC by the ICC Board as “areas of study”. Information on the CTC, including: meeting agendas; minutes; reports; resource documents; presentations; and all other materials developed in conjunction with the CTC effort can be downloaded from the following website: <http://www.iccsafe.org/cs/CTC/Pages/default.aspx>. Since its inception in April/2005, the CTC has held twenty two meetings - all open to the public.

This proposed change is a result of the CTC’s investigation of the area of study entitled “Labeling of Fire Rated Glazing”. The scope of the activity is noted as:

Identify root causes of problems selecting, specifying, installing, and inspecting fire protective and fire resistive glazing and other assembly components including the frames. Propose identification requirements and other related code changes.

The proposed changes to Section 716.5.8.4 and 716.6.3 are needed to clarify the code changes approved in the last code cycle to ensure that there is no question that Chapter 24 language covers both fire-protection-rated glazing and fire-resistance-rated glazing. Proposed language also addresses requirements for safety glazing not defined as hazardous locations by referencing compliance with Chapter 24. No technical changes are being introduced.

Cost Impact: The code change proposal will not increase the cost of construction.

FS95-12

Public Hearing:	Committee:	AS	AM	D
	Assembly:	ASF	AMF	DF

716.5.8.4-FS-BALDASSARRA-CTC

FS96 – 12

716.5.9

Proponent: Sharon S. Gilyeat, Koffel Associates, Inc., representing CHUTES International

Revise as follows:

716.5.9 Door closing. Fire doors shall be self- or automatic-closing in accordance with this section. ~~Self-closing chute intake doors shall not fail in a “door open” position in the event of a closer failure.~~

Exceptions:

1. Fire doors located in common walls separating sleeping units in Group R-1 shall be permitted without automatic- or self-closing devices.
2. The elevator car doors and the associated hoistway enclosure doors at the floor level designated for recall in accordance with Section 3003.2 shall be permitted to remain open during Phase I emergency recall operation.

Reason: In the last code cycle this change was made as part of FS 39. In my review of the documentation relating to the change, it appears that the proposal was attempting to ensure the door stayed closed and latched even if the closer was broken. In other words, the closer could not be the device keeping the door shut, the latch needed to do this. The changes that ultimately went into 715.4.8.1.1 accomplished this goal. It does not appear that it was intended for there be multiple door closing devices on the door.

It is not possible to have a chute door fail safe to the closed position if the self-closer is broken and the door is open at the time the closer fails. It is the closer that brings the door to the closed position. If this requirement were taken literally, it would require all intake doors to be top hinged. For safety reasons this is not acceptable as the doors are generally arranged to minimize the risk of someone falling into the chute inadvertently. This is why side or bottom hinged doors are used as loading doors. I believe this requirement is unclear. It is attempting to address a maintenance and inspection issue by adding more hardware.

Cost Impact: The code change proposal will not increase the cost of construction.

FS96-12

Public Hearing:	Committee:	AS	AM	D
	Assembly:	ASF	AMF	DF

716.5.9-FS-GILYEAT

FS97 – 12

716.5.9.3

Proponent: Sharon S. Gilyeat, Koffel Associates, Inc., representing CHUTES International

Revise as follows:

716.5.9.3 Smoke-activated doors. Automatic-closing doors installed in the following locations shall be automatic-closing by the actuation of smoke detectors installed in accordance with Section 907.3 or by loss of power to the smoke detector or hold-open device. Doors that are automatic-closing by smoke detection shall not have more than a 10-second delay before the door starts to close after the smoke detector is actuated:

1. Doors installed across a corridor.
2. Doors that protect openings in exits or corridors required to be of fire-resistance-rated construction.
3. Doors that protect openings in walls that are capable of resisting the passage of smoke in accordance with Section 509.4.
4. Doors installed in smoke barriers in accordance with Section 709.5.
5. Doors installed in fire partitions in accordance with Section 708.6.
6. Doors installed in a fire wall in accordance with Section 706.8.
7. Doors installed in shaft enclosures in accordance with Section 713.7.
8. Doors installed in ~~refuse and laundry waste and linen~~ chutes, discharge openings, and access and ~~termination~~ discharge rooms in accordance with Section 713.13. ~~Automatic-closing Chute intake loading doors installed in refuse and laundry waste and linen chutes shall also meet the requirements of Section 716.5.9 and 716.5.9.1.1.~~
9. Doors installed in the walls for compartmentation of underground buildings in accordance with Section 405.4.2.
10. Doors installed in the elevator lobby walls of underground buildings in accordance with Section 405.4.3.
11. Doors installed in smoke partitions in accordance with Section 710.5.2.3.

Reason: Editorial changes intended to use consistent terms throughout the ICC that correlate with NFPA 82. This change corresponds with the related change to 713.13.1. The industry standard is for the loading doors to remain normally closed and in the case of linen, to be secured. Allowing a loading door to a chute to be held open creates a safety risk. The risk of someone falling into the chute inadvertently is minimized by the door being normally closed.

Cost Impact: The code change proposal will not increase the cost of construction.

FS97-12

Public Hearing:	Committee:	AS	AM	D
	Assembly:	ASF	AMF	DF

716.5.9.3-FS-GILYEAT

FS98 – 12

716.5.9.3

Proponent: Philip Brazil, Reid Middleton, Inc., representing Washington Association of Building Officials, Technical Code Development Committee (pbrazil@reidmiddleton.com)

Revise as follows:

716.5.9.3 Smoke-activated doors. Automatic-closing doors installed in the following locations shall be automatic-closing by the actuation of smoke detectors installed in accordance with Section 907.3 or by loss of power to the smoke detector or hold-open device. Doors that are automatic-closing by smoke detection shall not have more than a 10-second delay before the door starts to close after the smoke detector is actuated:

1. Doors installed across a *corridor*.
2. Doors that protect openings in *exits* or *corridors* required to be of fire-resistance-rated construction.
3. Doors that protect openings in walls that are capable of resisting the passage of smoke in accordance with Section 509.4.
4. Doors installed in *smoke barriers* in accordance with Section 709.5.
5. Doors installed in *fire partitions* in accordance with Section 708.6.
6. Doors installed in a *fire wall* in accordance with Section 706.8.
7. Doors installed in shaft enclosures in accordance with Section 713.7.
8. Doors installed in refuse and laundry chutes and access and termination rooms in accordance with Section 713.13. Automatic-closing chute intake doors installed in refuse and laundry chutes shall also meet the requirements of Sections 716.5.9 and 716.5.9.1.1.
9. Doors installed in the walls for compartmentation of underground buildings in accordance with Section 405.4.2.
10. Doors installed in the elevator lobby walls of underground buildings in accordance with Section 405.4.3.
11. Doors installed in smoke partitions in accordance with Section 710.5.2.3.
12. Doors installed in the enclosures of *exit access stairways* and *ramps* in accordance with Sections 1009.3.1.4 and 1010.2, respectively.

Reason: The addition of Item 12 is for correlation with the reference to Section 716.5.9.3 in Section 1009.3.1.4 for exit access stairways and, by inference, in Section 1010.2 for exit access ramps, which specifies compliance with Section 1009.3 for enclosure of stairways.

Cost Impact: The code change proposal will not increase the cost of construction.

FS98-12

Public Hearing:	Committee:	AS	AM	D
	Assembly:	ASF	AMF	DF

716.5.9.3-FS-BRAZIL

FS99 – 12

202, 712.1.3.3 (New), 717 (New)

Proponent: Tom Meyer, Colorado Code Consulting, LLC, representing Stobich Fire Protection (tmeyers@coloradocode.net); Steve Thomas, Colorado Code Consulting, LLC, representing Stobich Fire Protection (sthomas@coloradocode.net)

THIS IS A 5 PART CODE CHANGE. ALL PARTS WILL BE HEARD BY THE IBC FIRE SAFETY COMMITTEE. SEE THE TENTATIVE HEARING ORDER FOR THIS COMMITTEE.

PART I – IBC FIRE SAFETY

Add new definition as follows:

Fire Curtain. A flexible membrane assembly constructed of materials designed to restrict the spread of fire when tested in accordance with UL 10D.

Add new text as follows:

SECTION 717 **FIRE AND SMOKE CURTAINS**

717.1 General. Fire and smoke curtains permitted by other sections of this code shall comply with the provisions of this section.

717.2 Fire Test Criteria. Fire and smoke curtains shall be tested in accordance with the requirements of UL 10D.

717.3 Activation. Fire and smoke curtains shall comply with the following criteria:

1. Fire and smoke curtains shall be actuated by approved spot-type detectors listed for releasing service.
2. Fire detection systems providing control input or output signals to fire and smoke curtains or elements thereof shall comply with the requirements of Section 907. Such systems shall be equipped with a control unit complying with UL 864 and listed as smoke control equipment.

(Renumber subsequent sections)

Add new standard to Chapter 35 as follows:

UL 10D-09 Outline of Investigation for Fire Tests for Fire Protective Curtains

PART II – IBC FIRE SAFETY

Add new text as follows:

712.1.3.3 Fire Curtains. Protection of the opening by approved fire curtains in accordance with Section 717 at every penetrated floor shall be permitted in accordance with this section. The curtain shall be so constructed as to close immediately upon the actuation of a smoke detector installed in accordance with Section 907.3.1 and shall completely shut off the well opening. Escalators shall cease operation when the curtain begins to close. The curtain shall operate at a speed of not more than 30 feet per minute (152.4 mm/s) and shall be equipped with a sensitive leading edge to arrest its progress where in contact with any obstacle, and to continue its progress on release there from.

PART III – IBC FIRE SAFETY

Add new text as follows:

721.1.18 Fire Curtains. Vertical floor openings shall be permitted where protected by a fire curtain in accordance with Section 717. Fire curtains shall achieve a fire-resistance rating not less than the assembly being penetrated, but need not exceed 2 hours.

(Renumber subsequent sections)

PART IV – IBC GENERAL

Revise as follows:

404.6 Enclosure of atriums. Atrium spaces shall be separated from adjacent spaces by a 1-hour fire barrier constructed in accordance with Section 707 or a horizontal assembly constructed in accordance with Section 711, or both.

Exception: A fire barrier is not required where a glass wall forming a smoke partition is provided. The glass wall shall comply with all of the following:

1. Automatic sprinklers are provided along both sides of the separation wall and doors, or on the room side only if there is not a walkway on the atrium side. The sprinklers shall be located between 4 inches and 12 inches (102 mm and 305 mm) away from the glass and at intervals along the glass not greater than 6 feet (1829 mm). The sprinkler system shall be designed so that the entire surface of the glass is wet upon activation of the sprinkler system without obstruction;
 - 1.1. The glass wall shall be installed in a gasketed frame in a manner that the framing system deflects without breaking (loading) the glass before the sprinkler system operates; and
 - 1.2. Where glass doors are provided in the glass wall, they shall be either self-closing or automatic-closing.
2. A fire barrier is not required where a glass-block wall assembly complying with Section 2110 and having a 3/4-hour fire protection rating is provided.
3. A fire barrier is not required between the atrium and the adjoining spaces of any three floors of the atrium provided such spaces are accounted for in the design of the smoke control system.
4. A fire barrier is not required between the atrium and the adjoining spaces when a fire curtain having a one-hour fire-resistance rating in accordance with Section 717 is installed at the perimeter of the atrium opening. The curtain shall not be placed in such a location as to obstruct the means of egress.

PART V – IBC MEANS OF EGRESS

Add new definition as follows:

1009.3 Exit access stairways. Floor openings between stories created by exit access stairways shall be enclosed.

Exceptions:

(No changes to Exceptions 1 through 10)

11. In other than Group I-2 and I-3 occupancies, stairways that serve, or atmospherically communicate between only four stories, and are not part of the required means of egress shall be permitted to be enclosed by a fire curtain installed in accordance with Section 717.

Reason: This proposal introduces fire curtains into the code to be used in protecting vertical openings. A new section has been proposed to address the requirements for a fire curtain in a new Section 717. The current code has several different ways to protect these openings. These curtains have been tested in accordance with UL 10D which is similar to UL 263 without the hose stream test. Horizontal assemblies are not required to pass the hose stream test. Therefore, the standards are similar in how they evaluate the system. The proposal is also creating a new definition to address the testing and installation requirements for the curtain. UL 10D has been specified as the test standard for the fire curtains. It is similar to other fire-resistance tests with the exception of a hose stream test.

Section 712.1.2 currently permits the installation of a draft curtain and closely spaced automatic sprinklers in lieu of providing a fire-resistant rated shaft enclosure. The intent of this requirement is to limit the amount of smoke and heat that can extend up through the opening created for an escalator. This proposal is intended to provide a third option to the designer to address the floor openings created by an escalator. The installation of a fire curtain is being presented as that option. A fire curtain can meet the requirement of a fire rated assembly, but has not been tested with a hose stream. A fire curtain will provide an equal level of protection, if not better, than the current draft curtain and sprinklers.

Section 721.1.18 would permit a horizontally deployed curtain that would enclose the vertical floor opening and provide the same protection as the horizontal assembly.

Section 404.6 requires that an atrium be separated from other spaces of the building by a one-hour fire barrier. The exceptions to that requirement permit the installation of a non-fire rated assembly in exception 1. The proposal permits the installation of a fire curtain around the perimeter of the atrium as an additional option. A fire curtain provides an equivalent level of protection to glass forming a smoke partition protected by automatic sprinklers outlined in exception 1. The intent of the exception is to provide a smoke separation at the atrium.

Section 1009.3 presents a new type of separation requirement for exit access stairways. It introduces the concept of fire curtains into the code and permits their use to enclose exit access stairs that serve a maximum of four stories. Fire curtains are tested to UL 10D which does not include the hose stream test. The intent is to allow an alternative to a full enclosure. The current code permits stairs to be open between adjacent stories without enclosure. This proposal is also consistent with the protection that Exceptions 3 and 4 of Section 1009.3 provides, with the draft curtain and closely spaced sprinklers.

Cost Impact: This change will reduce the cost of construction

Analysis: A review of the standard proposed for inclusion in the code, UL10D-09 with regard to the ICC criteria for referenced standards (Section 3.6 of CP#28) will be posted on the ICC website on or before April 2, 2012.

FS99-12

PART I – IBC FIRE SAFETY

Public Hearing:	Committee:	AS	AM	D
	Assembly:	ASF	AMF	DF

PART II – IBC FIRE SAFETY

Public Hearing:	Committee:	AS	AM	D
	Assembly:	ASF	AMF	DF

PART III – IBC FIRE SAFETY

Public Hearing:	Committee:	AS	AM	D
	Assembly:	ASF	AMF	DF

PART IV – IBC GENERAL

Public Hearing:	Committee:	AS	AM	D
	Assembly:	ASF	AMF	DF

PART V – IBC MEANS OF EGRESS

Public Hearing:	Committee:	AS	AM	D
	Assembly:	ASF	AMF	DF

712.1.3.3 (NEW)-FS-MEYERS-THOMAS-721.1.18 (NEW)-FS-MEYERS-THOMAS-404.6-FS-MEYERS-THOMAS-1009.3-FS-MEYERS-THOMAS

FS100 – 12

714.1.1 (New)

Proponent: Clay Aler, P.E., Koffel Associates, representing self

Add new text as follows:

717.1 General. The provisions of this section shall govern the protection of duct penetrations and air transfer openings in assemblies required to be protected and duct penetrations in nonfire-resistance-rated floor assemblies.

717.1.1 Ducts and Air Transfer Openings. Ducts transitioning horizontally between shafts shall not require a shaft enclosure provided that the duct penetration into each associated shaft is protected with dampers complying with the this section.

Reason: The code intent is to maintain the integrity of shaft enclosures when they are provided. The code intent is maintained by providing dampers in accordance with Section 717. The code intent is not to require a continuous shaft enclosure of main ducts where adequate protection of the individual shaft enclosures is maintained. The overriding intent is to maintain appropriate separation between stories within an enclosed building and to minimize the spread of fire and smoke through the use of dampers as ductwork leaves a shaft enclosure. Providing a continuous horizontal shaft enclosure with required supporting construction will have significant cost implications.

Cost Impact: The proposed code language will allow the designer to determine the approach taken to protect ductwork that must transition horizontally between shaft enclosures that are not continuous through all stories of a building. Designers choosing to provide dampers at each duct penetration of the associated discontinuous shaft enclosures should see a reduction in construction cost

FS100-12

Public Hearing:	Committee:	AS	AM	D
	Assembly:	ASF	AMF	DF

607.1.1-FS-ALER – 714.1.1-FS-ALER

FS101 – 12

717.2 (IMC 607.2)

Proponent: Umesh Kumar Bhargava, PE., Bhargava International, Inc., representing self

Revise as follows:

717.2 (IMC 607.2) Installation. *Fire dampers, smoke dampers, combination fire/smoke dampers and ceiling radiation dampers* located within air distribution and smoke control systems shall be installed in accordance with the requirements of this section, the manufacturer's installation instructions and the dampers' listing.

Exceptions:

1. The duct shall not exceed 7-inch (102 mm) nominal diameter and the total area of such ducts shall not exceed 100 square inches (0.065 m²) in any 100 square feet (9.3 m²) of floor area.
2. Duct shall be metallic thickness minimum 20 gauge, Where duct length exceeds 3 feet on either side of membrane penetration, duct shall be minimum 20 gauge up to 3 feet on either side of membrane penetration.
3. The duct shall open into only one dwelling or sleeping unit and the duct system shall be continuous from the unit to the exterior of the building.
4. Buildings equipped throughout with an automatic sprinkler system in accordance with Section 903.3.1.1 or 903.3.1.2.
5. The annular space around the duct is protected with materials that prevent the passage of flame and hot gases sufficient to ignite cotton waste where subjected to ASTM E 119 or UL 263 time-temperature conditions under a minimum positive pressure differential of 0.01 inch (2.49 Pa) of water at the location of the penetration for the time period equivalent to the *fire-resistance rating* of the construction penetrated.
6. Grille openings located in a ceiling of a fire-resistance- rated floor/ceiling or roof/ceiling assembly shall be protected with a *listed ceiling radiation damper* installed in accordance with Section 717.6.2.1.

Reason:

1. Fire dampers are available from any manufacturer for ceiling membrane penetration
2. Ceiling radiation dampers are applicable for thru penetration
3. Currently due to lack of fire damper or ceiling radiation damper availability, most authorities having jurisdiction officials are reluctantly permitting fire dampers, while admitting it is not correct application.
4. Metallic duct with fire stop system should provide protection

Cost Impact: None

FS101-12

Public Hearing:	Committee:	AS	AM	D
	Assembly:	ASF	AMF	DF

716.2-FS-BHARGAVA

FS102 – 12

717.1.2 (New) [(IMC607.1.2 (New))] , 717.5.2 (IMC 607.5.2), Chapter 35

Proponent: John D. Nicholas, Perceptive Solutions LLC, representing Unifrax I LLC
(john@perceptivesolutionsllc.com)

THIS IS A 2 PART CODE CHANGE. BOTH PARTS WILL BE HEARD BY THE IBC FIRE SAFETY COMMITTEE. SEE THE TENTATIVE HEARING ORDER FOR THIS COMMITTEE.

PART I – IBC FIRE SAFETY

Add new text as follows:

717.1.2 (IMC 607.1.2) Ducts that penetrate fire-resistance-rated assemblies. Ducts tested and listed in accordance with ASTM E2816 having a fire-resistance rating equal to the construction being penetrated that protect horizontal ducts penetrating fire-resistance-rated vertical assemblies or that protect vertical ducts or both are not required to have fire dampers.

Add new standard to Chapter 35 as follows:

ASTM
E2816 Standard Test Methods for Fire Resistive Metallic HVAC Duct Systems

PART II – IBC FIRE SAFETY

Revise as follows:

717.5.2 (IMC 607.5.2) Fire barriers. Ducts and air transfer openings of *fire barriers* shall be protected with *approved fire dampers* installed in accordance with their listing. Ducts and air transfer openings shall not penetrate enclosures for stairways, ramps and exit passageways except as permitted by Sections 1022.4 and 1023.6, respectively.

Exception: *Fire dampers* are not required at penetrations of *fire barriers* where any of the following apply:

1. Penetrations are tested in accordance with ASTM E 119 or UL 263 as part of the fire-resistance-rated assembly.
2. Ducts are used as part of an approved smoke control system in accordance with Section 909 and where the use of a fire damper would interfere with the operation of a smoke control system.
3. Such walls are penetrated by ducted HVAC systems, have a required fire-resistance rating of 1 hour or less, are in areas of other than Group H and are in buildings equipped throughout with an automatic sprinkler system in accordance with Section 903.3.1.1 or 903.3.1.2. For the purposes of this exception, a ducted HVAC system shall be a duct system for conveying supply, return or exhaust air as part of the structure's HVAC system. Such a duct system shall be constructed of sheet steel not less than No. 26 gage thickness and shall be continuous from the air-handling appliance or equipment to the air outlet and inlet terminals.
4. Ducts tested and listed in accordance with ASTM E2816 having a fire-resistance rating equal to the type of building construction being penetrated.

Add new standard to Chapter 35 as follows:

ASTM
E2816 Standard Test Methods for Fire Resistive Metallic HVAC Duct Systems

Reason: This proposal allows another means to provide fire protection in lieu of fire dampers when the duct complies with ASTM E2816-11, *Standard Test Methods for Fire Resistive Metallic HVAC Duct Systems*. The level of fire protection offered by the

proposal is typically greater than currently required by Table 717.3.2.1 for fire dampers. For example, a typical 2-hour fire-resistance rated construction only requires a fire damper having a 1-1/2-hour fire-resistance rating. The duct will maintain the same fire-resistance rating of the building construction being penetrated by the duct. Further, the duct will provide an insulation (temperature) rating where the fire damper is only required to provide an integrity (flame) rating.

These proposed code changes allow for the use of either a pre-fabricated duct system or field applied enclosure system. *ASTM E2816-11, Standard Test Methods for Fire Resistive Metallic HVAC Duct Systems* is a full consensus test method that was specifically designed to assess both specific end use of the ductwork and its protection materials.

ASTM E2816-11 provides tests for all four (4) possible duct system's configurations: Conditions A, B, C, and D. The application of these Conditions can be applied to specific types of duct system's use within a building. ASTM E2816 uses the ASTM E119 time-temperature curve and replicates use of exhaust by using a fan technique to create a negative pressure within the duct similar to that occurring while a cloth's drier exhaust system is in use. This method of tests also assesses both an internal and external fire threat to the duct as well as the transition or connection of horizontal ducts to vertical ducts. In ASTM E2816, the systems supports are also tested as part of the fire resistance test. ASTM E2816 offers the following tests to assess performance:

This method of tests uses the ASTM E119 time-temperature curve to test the ductwork and the enclosure materials. The Standard can evaluate the fire performance of HVAC ducts for both supply (pressurization) and return air, in the vertical and horizontal orientation, with or without openings. This method of tests also assesses both an internal and external fire threat to the duct as well as the transition or connection of horizontal ducts to vertical ducts.

ASTM E2816 References
1.4.1 <i>Condition A</i> —These test methods provide a means for evaluating a horizontal HVAC duct system, without openings exposed to fire, passing through a vertical fire-separating element.
1.4.2 <i>Condition B</i> —These test methods provide a means for evaluating a vertical HVAC duct system, without openings exposed to fire and outfitted with a horizontal connection, passing through a horizontal fire-separating element.
1.4.3 <i>Condition C</i> —These test methods provide a means for evaluating a horizontal HVAC duct system, with unprotected openings exposed to fire, passing through a vertical fire-separating element.
1.4.4 <i>Condition D</i> —These test methods provide a means for evaluating a vertical HVAC duct system with a horizontal connection, and with unprotected openings exposed to fire, passing through a horizontal fire-separating element.

The new ASTM Standard evaluates the HVAC duct systems for surface burning characteristics, non-combustibility, fire resistance, durability, and fire engulfment with horizontal and vertical through-penetration firestops. ASTM E2816-11 also contains provisions for testing other service attributes of the duct system. ASTM E84 is used for the system's flame spread and smoke developed indices: ASTM E136 is used for insulation's non-combustibility: ASTM C518 is used for the insulation's durability: ASTM E814 is used for the system's ability as a firestop to prevent the spread of fire from compartment to compartment: ASTM E2226 is used for the resistance to the application of a hose stream: and ASTM C411 is used for the insulation covering's and lining's ability to resist flaming, glowing, smoldering or smoking while in service, which was just approved in December 2011 and this test method will also become part of the standard upon its latest publication.

ICC-ES AC179, *Acceptance Criteria for Metallic HVAC Duct Enclosure Assemblies*, cites ASTM E2816-11 to establish requirements for fire protection enclosure systems, applied to metallic HVAC ducts, which provide an alternate to required fire-resistance-rated shafts or an alternate to required fire dampers in specific locations, as well as to determine the characteristics of the system and enclosure material currently cited in the codes. This criteria provides an alternate to shaft enclosures for vertical ducts, and an alternate to fire dampers in horizontal ducts (penetrating fire barriers, fire partitions, and or smoke barriers) and vertical ducts connecting multiple stories

These comments are respectfully submitted as the ASTM Task Group Chair of ASTM E2816 who drafted its first version, as the proponent of the latest approved revisions to ICC ES AC179 *Acceptance*

Criteria For Metallic HVAC Duct Enclosure Assemblies, as the ANSI Designated Expert to ISO TC92 Fire SC2 Fire Resistance WG4 that created and maintains ISO 6944 *Fire Containment — Elements of Building Construction — Part 1: Ventilation Ducts* and one who has designed, supervised, and overseen HVAC fire tests as a member of an international laboratory as well as the one who had jurisdiction over the product certification process for products and materials.

Cost Impact: This change will potentially reduce the cost of construction.

Analysis: FS 102, Part I and FS103 provide provisions for duct penetrations of fire rated assemblies. Also, FS 102, Part II and FS 109 provide similar provisions for ducts penetrating fire barriers. The committee needs to make its intent clear with respect to these provisions. A review of the standard proposed for inclusion in the code, ASTM E2816 with regard to the ICC criteria for referenced standards (Section 3.6 of CP#28) will be posted on the ICC website on or before April 2, 2012.

FS102
-12

PART I – IBC FIRE SAFETY

Public Hearing: Committee: AS AM D
Assembly: ASF AMF DF

PART II – IBC FIRE SAFETY

Public Hearing: Committee: AS AM D

Assembly:

ASF

AMF

DF

717.1.2 (NEW)-FS-NICHOLAS-717.5.2-fs-nicholas

FS103-12

717.1.2 (New) [(IMC 607.1.2 (New))], Chapter 35

Proponent: Tony Crimi, A.C. Consulting Solutions Inc, representing International Firestop Council (tcrimi@sympatico.ca)

Add new text as follows:

717.1.2 (IMC 607.1.2) Ducts that penetrate fire-resistance-rated assemblies. Fire dampers are not required in vertical or horizontal HVAC ducts penetrating vertical fire resistance-rated assemblies provided the duct system complies with the requirements of ASTM E2816-11.

Add new standard to Chapter 35 as follows:

ASTM

E2816-11 Standard Test Methods for Fire Resistive Metallic HVAC Duct Systems.

Reason: This proposal permits an additional exception to the requirement to install fire dampers in duct and air transfer openings through fire barriers provided the HVAC ducts are protected by a tested and listed assembly conforming to the new *ASTM E2816-11, Standard Test Methods for Fire Resistive Metallic HVAC Duct Systems* evaluated for the specific purpose. This ASTM test is now also referenced as part of ICC-ES AC179, Acceptance Criteria for Metallic HVAC Duct Enclosure Assemblies. The purpose of the acceptance criteria is to establish requirements for fire protection enclosure systems applied to metallic HVAC ducts, which provides an alternate to required fire-resistance-rated shafts or an alternate to required fire dampers in specific locations. This proposal mirrors the AC 179 acceptance criteria, which provides an alternate to shaft enclosures for vertical ducts, and an alternate to fire dampers in horizontal ducts (penetrating fire barriers, fire partitions, and or smoke barriers) and vertical ducts connecting multiple stories.

The test method evaluate the ability of a HVAC duct system to resist the spread of fire from one compartment to other compartments separated by a fire resistance rated construction when the HVAC duct system is exposed to fire under one or more of the following conditions:

- Condition A* — Fire exposure from the outside of the horizontal HVAC duct system without openings,
- Condition B* — Fire exposure from the outside of the vertical HVAC duct system without openings,
- Condition C* — Fire exposure from the outside with hot gases entering the inside of the horizontal HVAC duct system with unprotected openings, and
- Condition D* — Fire exposure from the outside with hot gases entering the inside of the vertical HVAC duct system with unprotected openings.

The new ASTM Standard evaluates the HVAC duct systems for surface burning characteristics, non-combustibility, fire resistance, durability, and fire engulfment with horizontal and vertical through-penetration firestops. The Standard can evaluate the fire performance of HVAC ducts for both supply (pressurization) and return air, in the vertical and horizontal orientation, with or without openings. These test methods evaluate the ability of a HVAC duct system to resist the spread of fire from one compartment to another compartment when subjected to the standard time-temperature curve of ASTM E119.

Cost Impact: This change will potentially reduce the cost of construction.

Analysis: FS 102, Part I and FS103 provide provisions for duct penetrations of fire rated assemblies. The committee needs to make its intent clear with respect to these provisions.

Public Hearing: Committee:	AS	AM	D
Assembly:	ASF	AMF	DF

717.2.1 (NEW)-FS-CRIMI

FS104-12

717.3.1 (IMC 607.3.1)

Proponent: Bob Eugene, representing Underwriters Laboratories (Robert.Eugene@ul.com)

Revise as follows:

717.3.1 (IMC 607.3.1) Damper testing. *Dampers* shall be listed and labeled in accordance with the standards in this section. *Fire dampers* shall comply with the requirements of UL 555. Only *fire dampers* and *ceiling radiation dampers* labeled for use in dynamic systems shall be installed in heating, ventilation and air-conditioning systems designed to operate with fans on during a fire. *Smoke dampers* shall comply with the requirements of UL 555S. *Combination fire/smoke dampers* shall comply with the requirements of both UL 555 and UL 555S. *Ceiling radiation dampers* shall comply with the requirements of UL 555C or shall be tested as part of a fire-resistance-rated floor/ceiling or roof/ceiling assembly in accordance with ASTM E119 or UL 263.

Reason: The code currently requires ceiling radiation dampers to comply with the requirements of the 2006 edition of UL 555C, with revisions through May 2010, which includes performance requirements for ceiling radiation dampers intended for use in dynamic HVAC systems where the airflow is operational at the time of a fire. The UL 555C standard requires ceiling radiation dampers investigated for use in dynamic systems to be marked for dynamic system use, along with the established airflow and closure pressure. This proposal will require the use of ceiling radiation dampers labeled for use in dynamic systems in these applications.

Cost Impact: None

FS104-12

Public Hearing:	Committee:	AS	AM	D
	Assembly:	ASF	AMF	DF

717.3.1-FS-EUGENE

FS105 – 12

202 (New), 717.3.1 (IMC 607.3.1), 717.3.3.5 (New) [(IMC 607.3.3.5 (New))]

Proponent: Vickie Lovell, InterCode Incorporated representing AMCA International
(vickie@intercodeinc.com)

Add new definition as follows:

COMBINATION CEILING RADIATION/SMOKE DAMPER. *A listed device installed in a ceiling membrane of a fire-resistance-rated floor/ceiling or roof/ceiling assembly designed to close automatically upon the detection of heat and resist the passage of heat and smoke. The device is installed to operate automatically, controlled by a smoke detection system, and where required, is capable of being positioned from a fire command center.*

Revise as follows:

717.3.1 (IMC 607.3.1) Damper testing. *Dampers shall be listed and labeled in accordance with the standards in this section. Fire dampers shall comply with the requirements of UL 555. Only ceiling radiation dampers labeled for use in dynamic systems or fire dampers labeled for use in dynamic systems shall be installed in heating, ventilation and air-conditioning systems designed to operate with fans on during a fire. Smoke dampers shall comply with the requirements of UL 555S. Combination fire/smoke dampers shall comply with the requirements of both UL 555 and UL 555S. Ceiling radiation dampers shall comply with the requirements of UL 555C or shall be tested as part of a fire-resistance-rated floor/ceiling or roof/ceiling assembly in accordance with ASTM E119 or UL 263.*

717.3.3.5 (IMC 607.3.3.5) Combination ceiling radiation/smoke damper actuation: *Combination ceiling radiation damper/smoke damper actuation shall be in accordance with Sections 717.3.3.2 and 717.3.3.4.*

Reason: This proposed code change clarifies that ceiling radiation dampers installed in HVAC systems where fans remain on during a fire must be labeled for use in dynamic systems to attest to their ability to close under heated airflow conditions. The 2012 IBC requires HVAC penetrations in the ceiling membrane of a rated floor ceiling assembly to be both a ceiling radiation damper and a smoke damper. For example, a fire rate corridor where the ceiling membrane is part of rated floor/ceiling assembly and the penetration is not protected by a shaft. In this example, IBC Section 717.6.2 requires a ceiling radiation damper where the duct opening penetrates the ceiling membrane **and** IBC Section 717.5.4.1 requires a smoke damper where the duct penetrates the corridor enclosure.

One solution for these situations is to provide a separate ceiling radiation damper and a separate smoke damper. The other solution is to provide a single combination ceiling radiation/smoke damper that meets the requirements of both a ceiling radiation damper and a smoke damper.

This code change clarifies that when a combination ceiling radiation/smoke damper is used it shall comply with the actuation requirements of **both** the ceiling radiation damper **and** the smoke damper.

Cost Impact: The code change proposal will not increase the cost of construction.

FS105-12

Public Hearing:	Committee:	AS	AM	D
	Assembly:	ASF	AMF	DF

717.3.1-FS-LOVELL

FS106 – 12

202, 702.1, 717.3.1, 717.3.2.4 (new), 717.3.3.5 (New), 717.5, 717.5.4.1

Proponent: Bob Eugene representing Underwriters Laboratories (Robert.Eugene@ul.com)

Revise as follows:

SECTION 202 DEFINITIONS

CORRIDOR DAMPER. A listed device intended for use where air ducts penetrate or terminate at horizontal openings in the ceilings of interior corridors, where the corridor ceiling is constructed as required for the corridor walls.

DAMPER. See “Ceiling radiation damper,” “Combination fire/smoke damper,” “Corridor damper.” “Fire damper” and “Smoke damper.”

Revise text as follows:

702.1 Definitions. The following terms are defined in Chapter 2:
CORRIDOR DAMPER

(Portions of text not shown remain unchanged)

717.3.1 Damper testing. Dampers shall be listed and labeled in accordance with the standards in this section.

1. Fire dampers shall comply with the requirements of UL 555. Only fire dampers labeled for use in dynamic systems shall be installed in heating, ventilation and air-conditioning systems designed to operate with fans on during a fire.
2. Smoke dampers shall comply with the requirements of UL 555S.
3. Combination fire/smoke dampers shall comply with the requirements of both UL 555 and UL 555S.
4. Ceiling radiation dampers shall comply with the requirements of UL 555C or shall be tested as part of a fire-resistance-rated floor/ceiling or roof/ceiling assembly in accordance with ASTM E119 or UL 263.
5. Corridor dampers shall comply with requirements of both UL 555 and UL 555S. Corridor dampers shall also demonstrate acceptable closure performance when subjected to 150 fpm (0.76 mps) velocity across the face of the damper during the UL 555 fire exposure test.

717.3.2.4 Corridor damper ratings. Corridor dampers shall have the following minimum ratings:

1. One hour fire-resistance rating.
2. Class I or II leakage rating as specified in Section 717.3.2.2.

717.3.3.5 Corridor damper actuation. Corridor damper actuation shall be in accordance with Sections 717.3.3.1 and 717.3.3.2.

717.5 Where required. *Fire dampers, smoke dampers, ~~and combination fire/smoke dampers,~~ ceiling radiation dampers and corridor dampers shall be provided at the locations prescribed in Sections 717.5.1 through 717.5.7 and 717.6. Where an assembly is required to have both *fire dampers* and *smoke dampers, combination fire/smoke dampers* or a *fire damper* and a *smoke damper* shall be ~~required~~ provided.*

717.5.4.1 Corridors. Duct and air transfer openings that penetrate corridors shall be protected with dampers as follows.

1. A corridor damper shall be provided where corridor ceilings, constructed as required for the corridor walls as permitted in Section 708.4, Exception 3, are penetrated.
2. A ceiling radiation damper shall be provided where the ceiling membrane of a fire-resistance-rated floor-ceiling or roof-ceiling assembly, constructed as permitted in Section 708.4, Exception 2, is penetrated.
3. A listed smoke damper designed to resist the passage of smoke shall be provided at each point a duct or air transfer opening penetrates a corridor enclosure required to have smoke and draft control doors in accordance with Section 716.5.3.

Exceptions:

1. *Smoke dampers* are not required where the building is equipped throughout with an approved smoke control system in accordance with Section 909, and *smoke dampers* are not necessary for the operation and control of the system.
2. *Smoke dampers* are not required in corridor penetrations where the duct is constructed of steel not less than 0.019 inch (0.48 mm) in thickness and there are no openings serving the corridor.

Reason: This proposal clarifies the appropriate types of dampers required to protect duct and air transfer openings that penetrate corridors. It accomplishes this as follows.

1. A new definition of corridor damper is proposed. These products have been around for several years, and 18 companies currently have corridor damper Listings.
2. IBC section 717.3.1 and 717.3.2.4 (IMC 607.3.1 and 607.3.2.4) describe the testing standards and ratings that corridor dampers must meet. Corridor dampers are listed for both a fire resistance rating of 1 hr, and a Class I or II leakage rating as defined by the Standard UL 555S. Leakage ratings of corridor dampers are determined at an elevated temperature 250°F or 350°F. Corridor dampers have also demonstrated acceptable closure performance when subjected to 150 fpm velocity across the face of the damper during fire exposure. Corridor dampers are only intended to be used to protect duct and air transfer openings in corridor ceilings, where the ceilings are constructed as required for the corridor walls (as permitted in Section 708.4, Exception 3.)
3. Section 717.3.3.5 (IMC 607.3.3.5) cover the actuation criteria for corridor dampers using existing criteria for both fire dampers and smoke dampers.
4. Language was added to Section 717.5.4.1 (IMC 607.5.4) describing the applications that require corridor dampers to be installed. Additional language was also added to indicate the applications in which a ceiling radiation damper is required to be installed, which was not covered in the current code.

Currently, Section 717.5.4.1, in conjunction with Sections 717.5.4 and/or 717.6.1, would imply these penetrations should be protected with combination fire/smoke dampers or fire dampers and smoke dampers. However, these devices are not designed and tested to be mounted in a wall installed in the horizontal orientation. The correct devices for this application are corridor dampers.

Cost Impact: None

Analysis: FS 106 and FS 107 provide similar provisions for corridor dampers. The committee needs to make its intent clear with respect to these provisions.

FS106-12

Public Hearing:	Committee:	AS	AM	D
	Assembly:	ASF	AMF	DF

202-CORRIDOR DAMPER (NEW)-G-EUGENE

FS107– 12

202, 717.3.2.4 (New) [IMC 607.3.2.4 (New)], 717.3.3 (IMC 607.3.3), 717.3.3.5 (New) [IMC 607.3.3.5 (New)], 717.5 (IMC 607.5), 717.5.4.1 (IMC 607.5.4)

Proponent: Joe Pierce, Dallas Fire Department, TX, representing the ICC Fire Code Action Committee

Revise as follows:

CORRIDOR DAMPER. A listed device intended for use where air ducts penetrate or terminate at horizontal openings in the ceilings of interior corridors, and where the corridor ceiling is constructed as required for the corridor walls.

DAMPER. See “Ceiling radiation damper,” “Combination fire/smoke damper,” “Corridor damper,” “Fire damper” and “Smoke damper.”

Revise as follows:

717.3.2.4 (IMC 607.3.2.4) Corridor dampers ratings. Corridor dampers shall be listed in accordance with applicable requirements in UL 555 and UL 555S for all of the following:

1. A minimum one-hour fire-resistance rating.
2. A Class I or II leakage rating established at an elevated temperature of minimum 250°F.
3. Acceptable closure performance when subjected to 150 fpm velocity across the face of the damper during fire exposure.

717.3.3 (IMC 607.3.3) Damper actuation. Damper actuation shall be in accordance with Sections 717.3.3.1 through ~~717.3.3.4~~ 717.3.3.5 as applicable.

717.3.3.5 (IMC 607.3.3.5) Corridor damper actuation. Corridor dampers shall close upon actuation of the fire damper actuation device in accordance with Section 717.3.3.1 or upon actuation of a listed smoke detector or detectors installed in accordance with Section 907.3 and one of the following methods, as applicable:

1. By a smoke detector installed in the duct within 5 feet (1524 mm) of the corridor damper with no air outlets or inlets between the detector and the damper. The detector shall be listed for the air velocity, temperature and humidity anticipated at the point where it is installed. Other than in mechanical smoke control systems, dampers shall be closed upon fan shutdown where local smoke detectors require a minimum velocity to operate.
2. By a smoke detection system installed in the corridor.
3. Where a total-coverage smoke detection system is provided within areas served by a heating, ventilation and air-conditioning (HVAC) system, corridor dampers shall be permitted to be controlled by the smoke detection system.

717.5 (IMC 607.5) Where required. *Fire dampers, smoke dampers, and combination fire/smoke dampers, ceiling radiation dampers and corridor dampers* shall be provided at the locations prescribed in Sections 717.5.1 through 717.5.7 and 717.6. Where an assembly is required to have both *fire dampers* and *smoke dampers, combination fire/smoke dampers* or a *fire damper* and a *smoke damper* shall be required.

717.5.4.1 (IMC 607.5.4) Corridors. A *listed smoke damper* designed to resist the passage of smoke shall be provided at each point a duct or air transfer opening penetrates a corridor enclosure required to have smoke and draft control doors in accordance with Section 716.5.3.

Exceptions:

1. *Smoke dampers* are not required where the building is equipped throughout with an approved smoke control system in accordance with Section 909, and *smoke dampers* are not necessary for the operation and control of the system.
2. *Smoke dampers* are not required in corridor penetrations where the duct is constructed of steel not less than 0.019 inch (0.48 mm) in thickness and there are no openings serving the corridor.
3. Smoke dampers are not required in corridor ceilings constructed as permitted in Section 708.4, Exception 3, provided the openings are protected with listed corridor dampers installed in accordance with their listings.

Reason: The IBC does not mention listed corridor dampers. UL 555 and UL 555S both evaluate dampers for installation in corridor ceilings and are titled “corridor dampers”. These dampers are listed specifically for this purpose.

IBC Section 202 is revised to include the definition of “corridor damper” and correlate the definition of “damper”.

Section 717.3.2.4 is added to specify the performance requirements for ceiling dampers. Dampers are required to be listed as meeting UL 555 or UL 555S and meet specific testing criteria.

Section 717.3.3 is revised to include the new section in the referenced sections.

Section 717.3.3.5 is added to provide specific language for actuation of the corridor damper.

Section 717.5 is revised to include the reference to corridor dampers, and include ceiling radiation dampers which are not included.

Section 717.5.4.1 is revised to add the requirement to use corridor dampers when the corridor ceiling is constructed as part of the fire partition for the corridor. This is the appropriate location for the corridor dampers to be installed.

Cost Impact: The code change will not increase the cost of construction.

Analysis: FS 106 and FS 107 provide similar provisions for corridor dampers. The committee needs to make its intent clear with respect to these provisions.

FS107-12

Public Hearing:	Committee:	AS	AM	D
	Assembly:	ASF	AMF	DF

717.3.2.4-FS-PIERCE-FCAC

FS108 – 12

717.3.3.2 (IMC 607.3.3.2)

Proponent: Al Godwin, CBO, CPM, representing Aon Fire Protection Engineering (al.godwin@aon.com)

Revise as follows:

717.3.3.2 (IMC 607.3.3.2) Smoke damper actuation. The *smoke damper* shall close upon actuation of a *listed* smoke detector or detectors installed in accordance with Section 907.3 and one of the following methods, as applicable:

1. Where a *smoke damper* is installed within a duct, a smoke detector installed in the duct, or smoke detector installed outside the duct with sampling tubes protruding into the duct, shall be installed ~~in the duct~~ within 5 feet (1524 mm) of the *damper* with no air outlets or inlets between the detector and the *damper*. The detector shall be *listed* for the air velocity, temperature and humidity anticipated at the point where it is installed. Other than in mechanical smoke control systems, *dampers* shall be closed upon fan shutdown where local smoke detectors require a minimum velocity to operate.
2. Where a *smoke damper* is installed above *smoke barrier* doors in a *smoke barrier*, a spot-type detector ~~listed for releasing service~~ shall be installed on either side of the *smoke barrier* door opening. The detector shall be listed for releasing service if used for direct interface with the damper.
3. Where a *smoke damper* is installed within an air transfer opening in a wall, a spot-type detector ~~listed for releasing service~~ shall be installed within 5 feet (1524 mm) horizontally of the *damper*. The detector shall be listed for releasing service if used for direct interface with the damper.
4. Where a *smoke damper* is installed in a *corridor* wall or ceiling, the *damper* shall be permitted to be controlled by a smoke detection system installed in the *corridor*.
5. Where a ~~total-coverage smoke detector~~ detection system is installed in provided within areas served by the duct in which the damper would be located, a heating, ventilation and air-conditioning (HVAC) system, ~~the~~ *smoke dampers* shall be permitted to be controlled by the smoke detection system.

Reason: This section has remained the same for a number of cycles and is outdated.

There are several things of concern related to this section. Firstly, in methods 2 and 3 above, spot-type detectors “listed for releasing service” are referenced. While a limited number of manufacturers produce these types of detectors, most do not and it should not be a requirement that the detectors used be listed for release service. This can be confirmed by research to the UL Fire Protection Equipment Directory, Category UROX. The interface to close dampers is most often achieved by using a relay module, not a relay on the detector or detector base.

Secondly, method 1 is an example of a detector being located “within” a duct. In most cases, detectors are located outside the duct with sampling tubes protruding into the duct. While the restrictions of this method are often applied to duct detectors with sampling tubes, it suggests that only detectors placed within the duct may be used.

Lastly method 5, in our opinion, has two faults. One, the definition of “total-coverage smoke detector system” is not appropriate for the intent of the section, and two, the location for detectors should not be based on areas served by the HVAC system but rather by the areas served by the duct in which the damper is located. We were unable to locate a total-coverage smoke detector system in the IBC. And the definition in NFPA 72 is located in Chapter 17. NFPA 72 requires detectors above ceilings in some cases. My firm has also been called on a case where a duct detector at a shaft was being replaced with detection in all areas served by the duct on one floor as part of a renovation. The smoke dampers on the floors above had duct detectors with sampling tubes. The AHJ stated that the HVAC system also serves the floors above and without full coverage on those levels they could not approve the design approach.

Also, of the 5 methods listed, method 5 is the only one that uses the plural of smoke dampers. All others apply to single dampers.

Cost Impact: There should be no cost impact as this is the standard method of installation.

FS108-12

Public Hearing:	Committee:	AS	AM	D
	Assembly:	ASF	AMF	DF

717.3.3.2-FS-GODWIN

FS109 – 12

717.5.2 (IMC 607.5.2), Chapter 35

Proponent: Tony Crimi, A.C. Consulting Solutions Inc, representing International Firestop Council (tcrimi@sympatico.ca)

Revise as follows:

717.5.2 (IMC 607.5.2) Fire barriers. Ducts and air transfer openings of *fire barriers* shall be protected with *approved fire dampers* installed in accordance with their listing. Ducts and air transfer openings shall not penetrate enclosures for stairways, ramps and exit passageways except as permitted by Sections 1022.4 and 1023.6, respectively.

Exception: *Fire dampers* are not required at penetrations of *fire barriers* where any of the following apply:

1. Penetrations are tested in accordance with ASTM E 119 or UL 263 as part of the fire-resistance rated assembly.
2. Ducts are used as part of an *approved* smoke control system in accordance with Section 909 and where the use of a *fire damper* would interfere with the operation of a smoke control system.
3. Such walls are penetrated by ducted HVAC systems, have a required *fire-resistance rating* of 1 hour or less, are in areas of other than Group H and are in buildings equipped throughout with an *automatic sprinkler system* in accordance with Section 903.3.1.1 or 903.3.1.2. For the purposes of this exception, a ducted HVAC system shall be a duct system for conveying supply, return or exhaust air as part of the structure's HVAC system. Such a duct system shall be constructed of sheet steel not less than No. 26 gage thickness and shall be continuous from the air-handling appliance or equipment to the air outlet and inlet terminals.
4. HVAC ducts comply with the requirements of ASTM E2816-11, Standard Test Methods for Fire Resistive Metallic HVAC Duct Systems.

Add new standard to Chapter 35 as follows:

ASTM

E2816-11, Standard Test Methods for Fire Resistive Metallic HVAC Duct Systems.

Reason: This proposal permits an additional exception to the requirement to install fire dampers in duct and air transfer openings through fire barriers provided the HVAC ducts are protected by a tested and listed assembly conforming to the new *ASTM E2816-11, Standard Test Methods for Fire Resistive Metallic HVAC Duct Systems* evaluated for the specific purpose.

This ASTM is now referenced as part of ICC-ES AC179, Acceptance Criteria for Metallic HVAC Duct Enclosure Assemblies. The purpose of these acceptance criteria is to establish requirements for fire protection enclosure systems applied to metallic HVAC ducts, which provides an alternate to required fire-resistance-rated shafts or an alternate to required fire dampers in specific locations. This proposal is consistent with AC 179 criterion providing an alternate to shaft enclosures for vertical ducts, and an alternate to fire dampers in horizontal ducts (penetrating fire barriers, fire partitions, and or smoke barriers) and vertical ducts.

The new ASTM Standard evaluates the HVAC duct systems for surface burning characteristics, non-combustibility, fire resistance, durability, and fire engulfment with horizontal and vertical through-penetration firestops. The Standard evaluates the fire performance of HVAC ducts for both supply (pressurization) and return air, in the vertical and horizontal orientation, with or without openings. These test methods evaluate the ability of a HVAC duct system to resist the spread of fire from one compartment to another compartment when subjected to the standard time-temperature curve of ASTM E119.

The test method evaluates the ability of a HVAC duct system to resist the spread of fire from one compartment to another compartment separated by a fire resistance rated construction when the HVAC duct system is exposed to fire under one or more of the following conditions:

Condition A— Fire exposure from the outside of the horizontal HVAC duct system without openings,

Condition B— Fire exposure from the outside of the vertical HVAC duct system without openings,

Condition C— Fire exposure from the outside with hot gases entering the inside of the horizontal HVAC duct system with unprotected openings, and

Condition D— Fire exposure from the outside with hot gases entering the inside of the vertical HVAC duct system with unprotected openings.

Cost Impact: This change will potentially reduce the cost of construction.

Analysis: FS 102, Part II and FS 109 provide similar provisions for ducts penetrating fire barriers. The committee needs to make its intent clear with respect to these provisions. A review of the standard proposed for inclusion in the code, ASTM E2816-11 with regard to the ICC criteria for referenced standards (Section 3.6 of CP#28) will be posted on the ICC website on or before April 2, 2012.

FS109-12

Public Hearing:	Committee:	AS	AM	D
	Assembly:	ASF	AMF	DF

717.5.2-FS-CRIMI

FS110 – 12

717.5.3 (IMC 607.5.5)

Proponent: Al Godwin, CBO, CPM, representing Aon Fire Protection Engineering (al.godwin@aon.com)

Revise as follows:

717.5.3 (IMC 607.5.5) Shaft enclosures. Shaft enclosures that are permitted to be penetrated by ducts and air transfer openings shall be protected with approved fire and smoke dampers installed in accordance with their listing.

Exceptions:

1. Fire dampers are not required at penetrations of shafts where:
 - 1.1. Steel exhaust subducts are extended at least 22 inches (559 mm) vertically in exhaust shafts, provided there is a continuous airflow upward to the outside; or
 - 1.2. Penetrations are tested in accordance with ASTM E 119 or UL 263 as part of the fire-resistance-rated assembly; or
 - 1.3. Ducts are used as part of an approved smoke control system designed and installed in accordance with Section 909 and where the fire damper will interfere with the operation of the smoke control system; or
 - 1.4. The penetrations are in parking garage exhaust or supply shafts that are separated from other building shafts by not less than 2-hour fire-resistance-rated construction.
2. In Group B and R occupancies equipped throughout with an automatic sprinkler system in accordance with Section 903.3.1.1, smoke dampers are not required at penetrations of shafts where:
 - 2.1 Kitchen, clothes dryer, bathroom and toilet room exhaust openings are installed with steel exhaust subducts, having a minimum wall thickness of 0.0187-inch (0.4712 mm) (No. 26 gage);
 - 2.2. The subducts extend at least 22 inches (559 mm) vertically; and
 - 2.3. An exhaust fan is installed at the upper terminus of the shaft that is powered continuously in accordance with the provisions of Section 909.11, so as to maintain a continuous upward airflow to the outside.
 - 2.4 Kitchen systems, clothes dryer systems, and bathroom and toilet room systems are permitted to share the same shaft but not the same duct. Where multiple ducts are in the same shaft, each system shall have its own fan providing continuous upward flow, as required by Sections 504 and 505 of the International Mechanical Code.
 - 2.5 Dryer ducts shall have a cleanout located near the shaft penetration to permit cleaning of the 22" subduct. The subduct shall be considered in the calculation of allowable duct length reduction.
 - 2.6 Kitchen ducts shall be provided with an approved method for preventing grease buildup and cleaning of the duct.
3. Smoke dampers are not required at penetration of exhaust or supply shafts in parking garages that are separated from other building shafts by not less than 2-hour fire-resistance-rated construction.
4. Smoke dampers are not required at penetrations of shafts where ducts are used as part of an approved mechanical smoke control system designed in accordance with Section 909 and where the smoke damper will interfere with the operation of the smoke control system.
5. Fire dampers and combination fire/smoke dampers are not required in kitchen and clothes dryer exhaust systems when installed in accordance with the International Mechanical Code.

Reason: Since exception 2 has been installed in the IBC, it has been incomplete. The IMC has done a good job of updating the provisions for common ducts with clothes dryers but nothing has been done for domestic kitchens.

Designers would not go to the expense of installing a shaft for domestic kitchen exhaust if there was not a smoke issue. When expensive condo's install super domestic kitchens, there is going to be smoke.

Also, IMC Section 505.1 specifically requires systems with downdraft exhaust to discharge to the exterior. How is that going to

be done in a multi-story building?

And, where there is smoke, there is grease. Thus, provisions are needed for kitchen exhaust and such exhaust needs to be separate from bathroom/toilet exhaust.

The designer should take some responsibility for controlling grease discharge, but specifics are left to his/her discretion.

Long dryer ducts have to install a 90 degree riser at the very end of their discharge, the weakest point. A cleanout is appropriate.

Perhaps someone has a better idea, but this should be a start.

Cost Impact: This code proposal will not increase the cost of construction since this is the method it should be designed to and it is less expensive than installation of a Type I hood.

Analysis: FS 110 proposes revisions for kitchen and dryer exhaust ducts in Groups B and R. FS 112 proposes to delete these provisions. The committee needs to make its intent clear with respect to these provisions.

FS110-12

Public Hearing:	Committee:	AS	AM	D
	Assembly:	ASF	AMF	DF

717.5.3-FS-GODWIN

FS111 – 12

717.5.3 (IMC 607.5.5)

Proponent: Guy McMann MCP, Jefferson County Colorado, representing Colorado Association of Plumbing and Mechanical Officials (CAPMO) (gmcman@jeffco.us)

Revise as follows:

717.5.3 (IMC 607.5.5) Shaft enclosures. Shaft enclosures that are permitted to be penetrated by ducts and air transfer openings shall be protected with approved fire and smoke dampers installed in accordance with their listing.

Exceptions:

1. Fire dampers are not required at penetrations of shafts where:
 - 1.1. Steel exhaust subducts are extended at least 22 inches (559 mm) vertically in exhaust shafts, provided there is a continuous airflow upward to the outside; or
 - 1.2. Penetrations are tested in accordance with ASTM E 119 or UL 263 as part of the fire-resistance-rated assembly; or
 - 1.3. Ducts are used as part of an approved smoke control system designed and installed in accordance with Section 909 and where the fire damper will interfere with the operation of the smoke control system; or
 - 1.4. The penetrations are in parking garage exhaust or supply shafts that are separated from other building shafts by not less than 2-hour fire-resistance-rated construction.
2. In Group B and R occupancies equipped throughout with an automatic sprinkler system in accordance with Section 903.3.1.1, smoke dampers are not required at penetrations of shafts where:
 - 2.1. Kitchen, clothes dryer, bathroom and toilet room exhaust openings are installed with steel exhaust subducts, having a minimum wall thickness of 0.187-inch (0.4712 mm) (No. 26 gage);
 - 2.2. The subducts extend at least 22 inches (559 mm) vertically; and
 - 2.3. An exhaust fan is installed at the upper terminus of the shaft that is powered continuously in accordance with the provisions of Section 909.11, so as to maintain a continuous upward airflow to the outside.
3. Smoke dampers are not required at penetration of exhaust or supply shafts in parking garages that are separated from other building shafts by not less than 2-hour fire-resistance-rated construction.
4. Smoke dampers are not required at penetrations of shafts where ducts are used as part of an approved mechanical smoke control system designed in accordance with Section 909 and where the smoke damper will interfere with the operation of the smoke control system.
5. ~~Fire dampers and combination fire/smoke dampers are not required in kitchen and clothes dryer exhaust systems when installed in accordance with the International Mechanical Code~~

Reason: This text has nothing to do with shafts and is improperly located. This information is covered completely in the IMC.

Cost Impact: None

FS111-12

Public Hearing:	Committee:	AS	AM	D
	Assembly:	ASF	AMF	DF

717.5.3-FS-MCMANN

FS112 – 12

717.5.3 (IMC 607.5.5)

Proponent: Ray Grill, P.E., Arup, representing self (Ray.Grill@arupgp.com)

Revise as follows:

717.5.3 (IMC 607.5.5) Shaft enclosures. Shaft enclosures that are permitted to be penetrated by ducts and air transfer openings shall be protected with *approved* fire and smoke *dampers* installed in accordance with their listing.

Exceptions:

- ~~1. *Fire dampers* are not required at penetrations of shafts where:
 - 1.1. Steel exhaust subducts are extended at least 22 inches (559 mm) vertically in exhaust shafts, provided there is a continuous airflow upward to the outside; or
 - 1.2. Penetrations are tested in accordance with ASTM E 119 or UL 263 as part of the fire-resistance-rated assembly; or
 - 1.3. Ducts are used as part of an *approved* smoke control system designed and installed in accordance with Section 909 and where the *fire damper* will interfere with the operation of the smoke control system; or
 - 1.4. The penetrations are in parking garage exhaust or supply shafts that are separated from other building shafts by not less than 2-hour fire-resistance-rated construction.~~
- ~~2. In Group B and R occupancies equipped throughout with an *automatic sprinkler system* in accordance with Section 903.3.1.1, *smoke dampers* are not required at penetrations of shafts where:
 - 2.1. Kitchen, clothes dryer, bathroom and toilet room exhaust openings are installed with steel exhaust subducts, having a minimum wall thickness of 0.0187-inch (0.4712 mm) (No. 26 gage);
 - 2.2. The subducts extend at least 22 inches (559 mm) vertically; and
 - 2.3. An exhaust fan is installed at the upper terminus of the shaft that is powered continuously in accordance with the provisions of Section 909.11, so as to maintain a continuous upward airflow to the outside.~~
- ~~3. *Smoke dampers* are not required at penetration of exhaust or supply shafts in parking garages that are separated from other building shafts by not less than 2-hour fire-resistance-rated construction.~~
- ~~4. *Smoke dampers* are not required at penetrations of shafts where ducts are used as part of an *approved* mechanical smoke control system designed in accordance with Section 909 and where the *smoke damper* will interfere with the operation of the smoke control system.~~
1. Fire and smoke dampers are not required where steel exhaust subducts extend at least 22 inches (559 mm) vertically in exhaust shafts provided there is a continuous airflow upward to the outside.
2. Fire dampers are not required where penetrations are tested in accordance with ASTM E 119 as part of the fire-resistance rated assembly.
3. Fire and smoke dampers are not required where ducts are used as part of an approved smoke-control system in accordance with Section 909.
4. Fire and smoke dampers are not required where the penetrations are in parking garage exhaust or supply shafts that are separated from other building shafts by not less than two-hour fire-resistance-rated construction.
5. Smoke dampers are not required where the building is equipped throughout with an automatic sprinkler system in accordance with Section 903.3.1.1.
56. *Fire dampers* and *combination fire/smoke dampers* are not required in kitchen and clothes dryer exhaust systems when installed in accordance with the *International Mechanical Code*.

Reason: This revision is consistent with amendments that have been in place in Virginia and the District of Columbia since the first adoption of the IBC.

There was never a technical basis for requiring smoke dampers at all shaft penetrations when it was first adopted during the comment period of the initial 2000 IBC development.

This requirement did not exist in any of the model building codes (BOCA, UBC & SBC) or in NFPA 101 (Life Safety Code). There have been proposals to add smoke dampers to all shaft penetrations in the NFPA codes for the last three cycles of code development and they have been rejected by the membership every time.

The justification for smoke dampers in the original code change is that smoke can travel through a duct to locations in a building that are remote from the fire. While this statement is correct, smoke travel through ducted ventilation shafts has not been a contributing factor to fire deaths in buildings. Smoke detectors at HVAC equipment have been a requirement to accomplish automatic shut off to minimize the potential of smoke spread through ventilation ducts. For example, the majority of fire deaths in upper stories of the MGM grand fire of 1980 were due to smoke spread through stair shafts and seismic joints that were not protected. Fancoil units in guestrooms drew air from the corridors which also contributed to fatalities. While the HVAC system was cited as a potential source of smoke spread, smoke detectors were not present to provide automatic shutoff of equipment (NFPA Preliminary Report of the MGM Grand Hotel Fire). There was only one fatality in an upper story of the San Juan DuPont fire in 1986 which was not readily explained. Smoke travel through ventilation shafts was not a contributing factor in the First Interstate fire in Los Angeles or the Meridian fire in Philadelphia.

Even in the World Trade Center bombing of 1993, 6 fatalities were attributed to the explosion, but there were no fatalities due to the effects of smoke (Isner, Michael S. and Klem, Thomas J., "World Trade Center Explosion and Fire," National Fire Protection Association).

While these fires were thoroughly investigated, and code changes promulgated to address fire safety issues, smoke dampers in duct penetrations of shafts were never adopted as changes to any of the model codes as a result of these fires.

There have been modifications to this section every cycle to correct the challenges with the application of the requirement. Exceptions for B and R don't make sense from a hazard or potential fire spread perspective.

Performance of Fully Sprinklered Buildings

It is important to note that the IBC requires sprinkler protection for most buildings of any significant size or occupant load (see section 903). Therefore, the performance of sprinklered buildings is relevant. There has never been a multiple life loss fire in a fully sprinkler building of any occupancy type where the occupants have not been intimate with the fire or where an explosive or terrorist event has occurred.

The original submitter of the code change in adding the additional smoke dampers does not question the reliability of sprinklers, he questions whether a 98% success factor is adequate to justify not having smoke dampers at duct penetrations and shafts. There were no fire incidents identified as part of the code change to demonstrate the need. The need for smoke dampers at ventilation shafts as a general requirement had never before been considered to be necessary to provide a reasonable level of life safety even in unsprinklered buildings.

Implications of the Requirement

The requirement for installation of smoke dampers drives additional features and requirements. These include a smoke detector in the duct to activate the damper which would be required to be supervised and connected to a fire alarm panel. HVAC controls and logic would be required to cause the appropriate damper operation upon smoke detector initiation. Ongoing maintenance and testing of the above devices is required on a regular frequency to assure operability.

Implementation of these requirements is not feasible in many instances. Smoke detectors in exhaust ducts from showers, dryers, kitchens, and other locations that produce aerosols or other materials that could trigger smoke detectors, are subject to unwanted alarms. Unwanted alarms on systems that are monitored off-site result in the fire department responding unnecessarily. This presents an added risk to firefighters.

A rough installed cost estimate for the smoke dampers and associated required equipment ranges from \$1500-\$3000 per damper or even more for large dampers. This does not include the ongoing cost of testing the dampers and detectors.

Cost Impact: Approval of this change will reduce the cost of construction in fully sprinklered buildings anywhere from \$1500-\$3000 for each smoke damper that would have been installed. This estimate includes the smoke dampers and associated required equipment. This does not include the ongoing cost of testing the dampers and detectors.

Analysis: FS 110 proposes revisions for kitchen and dryer exhaust ducts in Groups B and R. FS 112 proposes to delete these provisions. The committee needs to make its intent clear with respect to these provisions.

FS112-12

Public Hearing:	Committee:	AS	AM	D
	Assembly:	ASF	AMF	DF

717.5.3-FS-GRILL

FS113 – 12

717.5.5 (IMC 607.5.4)

Proponent: Barry Gupton, PE, NC Department of Insurance, Office of State Fire Marshal, Engineering Division (barry.gupton@ncdoi.gov)

Revise as follows:

717.5.5 (IMC 607.5.4) Smoke Barriers. A listed smoke damper designed to resist the passage of smoke and a listed fire damper, or a listed combination fire/smoke damper, shall be provided at each point a duct or air transfer opening penetrates a smoke barrier. Smoke dampers and smoke damper actuation methods shall comply with Section 717.3.3.2

Exceptions:

1. Smoke dampers are not required where the openings in ducts are limited to a single smoke compartment and the ducts are constructed of steel.
2. Fire dampers are not required where the code does not require fire dampers for duct penetrations of fire barriers or fire-resistant-rated horizontal assemblies.

Reason: The current wording of the section does not address the required fire-rating portion of the barrier. Clearly indicates the use of combination fire/smoke dampers. Coordinates the section with the requirements of the IMC.

Cost Impact: The code change proposal will not increase the cost of construction.

FS113-12

Public Hearing:	Committee:	AS	AM	D
	Assembly:	ASF	AMF	DF

717.5.5-FS-GUPTON

FS114 – 12

717.5.5 (IMC 607.5.4)

Proponent: John Williams, CBO, Chair, ICC Ad Hoc Committee on Healthcare

Revise as follows:

717.5.5 (IMC 607.5.4) Smoke barriers. *A listed smoke damper designed to resist the passage of smoke shall be provided at each point a duct or air transfer opening penetrates a smoke barrier. Smoke dampers and smoke damper actuation methods shall comply with Section 717.3.3.2.*

Exceptions:

1. Smoke dampers are not required where the openings in ducts are limited to a single smoke compartment and the ducts are constructed of steel.
2. Smoke dampers are not required in ambulatory care facilities and Group I-2 hospital occupancies where the HVAC system is fully ducted in accordance with Section 603 of the *International Mechanical Code* and where buildings are equipped throughout with an automatic sprinkler system in accordance with Sections 903.3.1.1 and equipped with quick response sprinklers in accordance with Section 903.3.2.

Reason: This proposal is submitted by the ICC Ad Hoc Committee for Healthcare (AHC). The AHC was established by the ICC Board of Directors to evaluate and assess contemporary code issues relating to hospitals and ambulatory healthcare facilities. The AHC is composed of building code officials, fire code officials, hospital facility engineers, and state healthcare enforcement representatives. The goals of the committee are to ensure that the ICC family of codes appropriately addresses the fire and life safety concerns of a highly specialized and rapidly evolving healthcare delivery system. This process is part of a joint effort between ICC and the American Society for Healthcare Engineering (ASHE), a subsidiary of the American Hospital Association, to eliminate duplication and conflicts in healthcare regulation. Since its inception in April, 2011, the AHC has held 5 open meetings and over 80 workgroup calls which included members of the AHC as well as any interested party to discuss and debate the proposed changes. All meeting materials and reports are posted on the AHC website at: <http://www.iccsafe.org/cs/AHC/Pages/default.aspx>

Duct smoke dampers at smoke barrier walls in facilities fully protected with electronically supervised, tested and maintained quick response automatic sprinkler systems should be omitted from the I-codes, have not been required by other model codes and have shown a history of success without the additional dampers. In preparation for this proposal the AHC asked Rolf Jensen & Associates (RJA) to review and provide comments on the "Smoke Damper Evaluation for Air Movement & Control Association International, Inc." analysis and dated May 14, 2010. A copy of their summary can be found at www.iccsafe.org.

The supporting information, summarized by RJA for the AHC, describes information gathered in the years since quick response sprinklers (QRS) have been deployed. Untenable conditions are typically measured in amount of heat, obscuration of exit signs, and carbon monoxide levels. The studies summarized these conditions taking approximately 2 hours to 2-1/2 hours to reach untenable levels. Considering non-smoking policies in hospitals, use of Class A materials, and overall reduction of items to fuel a fire, it is highly unlikely to reach the constant burning levels noted in the study. However, even if judged in those timeframes noted in the report, the actual responder timeframe should enter into the equation. The following summarizes emergency responder timeframes:

Alarm is sounded, either by manual pull by the staff or by the automatic smoke detection system (most likely an addressable system)

- Staff employs defend-in-place method, which includes shutting doors to the origin of the fire and relocating patients out of the immediate area (i.e. to the other side of the compartment smoke barrier)
- Within 10 minutes of alarm, the fire department arrives
- In the context of the fire response, doors are opened by the fire department to find the source of the fire. These are the doors that automatically closed upon initiation of the alarm. Any mechanical system is now out of the equation, because of the active use of the doorways in the fire response, or if needed, the patient movement away from the room of origin.

In conclusion, the meaningful time of the fire protection of the building occurs in the first 30 minutes of the fire incident, when decisions are made by fire professionals and the safety staff of the hospital in terms of status of the patients. Quick response sprinklers are more often noted as the most important feature of the overall building fire protection system, and are demonstrated to be effective in containing spread of the fire than dampering of the duct system.

Please note that this proposal deals only with smoke zone barrier walls. It is not proposed to change the requirement for these dampers at shafts or at the air handler units.

The RJA comments are as follows:

Evaluations of recent automatic sprinkler performance data and smoke movement analysis report for smoke dampers revealed the following:

1. In 3,750 fires reported over the years of 2003 – 2006 in hospitals, mental health and substance abuse facilities; one civilian death was recorded. That individual was within the room of fire origin within a mental health facility and started the fire.
2. The overwhelming majority (i.e. 97+%) of fires within these facilities did not extend beyond the room of origin, despite having an automatic suppression system present in only 57% of reported fires.
3. Automatic sprinkler protection in a hospital has higher reliability and better performance than other occupancies. In over 1,600 fires in hospitals spanning 2003 - 2006, when sprinklers were present and the fires were large enough to activate an automatic suppression system, those systems showed a 97% operational reliability and were effective 100% of the time.
4. The requirements for electronically supervised hydraulically designed automatic sprinkler system increases the system reliability
5. Properly documented testing and maintenance improves the reliability of these systems. CMS holds healthcare facility operators accountable for the testing and maintenance requirements of NFPA 25. Verification of this documentation and maintenance records are checked every 1 to 3 years.
6. Tenable conditions are present in the smoke movement analysis for sprinklered buildings with or without smoke dampers.
7. Tenable conditions in non sprinklered configurations can be maintained for test fire duration of 30 minutes beyond room of origin.

Due the required automatic system design requirements, the limited smoke movement in a fully sprinklered building, required testing and maintenance of these suppression systems, the omission of smoke dampers is justified. There are still multiple safeguards to protect the building occupants from a multiple loss of life fire.

The use of smoke dampers between smoke zones in hospitals protected with Quick Response automatic Sprinklers (QRS) is being evaluated based on the reports of fire outcomes in hospitals; automatic sprinkler system reliability, performance, and effectiveness; and an assessment of previous smoke movement work in non sprinklered configurations.

NFPA issued an updated report on automatic sprinkler performance in two different reports ⁽¹⁾⁽²⁾. The reported data has been reviewed and evaluated for hospital facilities when possible. The failure modes will be reviewed and addressed based on current Building Code and Fire Code requirements.

Jennifer Flynn's report ⁽²⁾ shows there were 3,750 fires reported to have occurred over the years of 2003 – 2006 in hospitals, mental health, substance abuse and medical office type facilities. In all those fires, one fatality was reported, and that fatality occurred within the room of fire origin. That one fatality occurred as a result of a mental health patient using flammable liquids and igniting the mattress and other materials within his room.

Of reported 2003-2007 structure fires in health care properties, an estimated 57% showed sprinklers present, with higher percentages for hospitals (71%) and nursing homes (65%) and a much lower percentage for clinics and doctor's offices (28%). Sprinklers were also reported as present in half or more of all reported fires in laboratories (60%), manufacturing facilities (52%), theaters (50%), and prisons and jails (50%). In every other property use, more than half of all reported fires had no sprinklers.

Hospitals have the highest percentage of automatic sprinklers present in all the occupancies analyzed in this report. Despite suppression systems being present in only 57% of health care properties where fires were reported, those fires only extended beyond the room of origin in less than 3 percent of all reported fires. This can be directly attributed to the **R.A.C.E.** training medical staff are mandated to receive annually. The **C** in RACE relates to *confining* the fire. More simply, medical staff are trained to close the doors in rooms where fires ignite, after they **R**escue patients near the fire origin and **A**lert others of the presence of the fire.

For most property use groups and most types of automatic extinguishing equipment, the majority of reported fires were too small to activate operational equipment.

When automatic extinguishing equipment was present, the percentages of fires too small to activate operating equipment, based on overall reported structure fires, were as follows:

- 65% for all sprinklers,
- 65% for wet pipe sprinklers,
- 70% for dry pipe sprinklers,
- 61% for dry (or possibly wet) chemical systems,
- 43% for carbon dioxide systems,
- 66% for foam systems, and
- 59% for halogen systems.

Sprinklers in the area of fire failed to operate in only 7% of reported structure fires large enough to activate sprinklers. Based on Table A ⁽¹⁾, non confined fires larger than the sprinkler design area happened less than 2.0 % of the total non-confined and confined structure fires for healthcare buildings. These fires may affect a large part of a smoke compartment but they rarely happen.

Table 3A ⁽¹⁾ indicates the percentage of effective operation of sprinklers in 620 fires large enough for sprinkler activation at 87% in all healthcare related facilities. The Flynn report breaks this down by type of healthcare facility. Where sprinklers were present and the fire was large enough to operate the sprinklers in hospitals alone, sprinklers were effective 100 percent of the time.

The assessment of automatic sprinkler failures are summarized in Table 4A ⁽¹⁾. However, healthcare or hospitals are not separated as an occupancy type.

The reason sprinklers fail to operate in all occupancies are:

1. System turned off	53%
2. Inappropriate suppression system	20%
3. Lack of Maintenance	15%
4. Manual intervention	9%
5. System component damages	2%

In new and existing hospitals, the automatic sprinkler systems require electronic supervision. This supervision will typically address the major (53%) reason for system failure. This analysis is limited to hospitals. Automatic water based suppression is the appropriate means to control fires in this healthcare occupancy. This addresses 20% of the documented failures. Automatic water based suppression systems are required for all new hospitals and all renovations over 4000 square feet. 73% of the failures are addressed by electronically supervised automatic sprinkler systems.

Lack of maintenance is addressed by the CMS enforcement which ensures facilities follow NFPA 25. Existing healthcare facilities are required to document the NFPA 25 inspection, testing and maintenance on all water based suppression systems. Through contracts with state public health and fire marshal's offices that direct periodic surveys, CMS ensures that the needed inspection, testing and maintenance is provided in health care facilities. This work will also identify damaged system components. The required testing and maintenance and damage will address 17% of the documented failures.

Manual intervention is a fire service function. Standard operating procedures recommend determining the fire no longer poses a threat before shutting the system down.

The Hall report ⁽¹⁾ also notes reasons for ineffectiveness of systems. This category addresses the effectiveness of a system not the failure. These systems still operated but not at the design intent. These have 2 major categories. Extinguishing agent did not reach the fire and not enough extinguishing agent available.

Shielded fires are the first category. These can be addressed by proper design. Small shielded fires under tables or beds are within the design parameters of a NFPA 13 compliant sprinkler system. Missing areas under duct work or within storage racks are the typical issues in this category. These types of items, if missed in the initial design and installation, should be identified in the ongoing testing and maintenance required by NFPA 25.

Insufficient extinguishing agent addresses inadequate water supply and partially closed valves. Proper maintenance and testing will identify a deteriorating water supply. The electronic supervision required for the hospital sprinkler system will send a trouble alarm to the fire alarm panel for partially closed control valves.

The hydraulically designed, electronically supervised, and regularly tested and maintained automatic sprinkler system is substantially more reliable than the current performance data indicate. Fire loss data also shows there has not been a documented multiple loss of live fire due to fire in a fully sprinklered building.

This sprinkler system analysis was done to evaluate the current data and how it relates to hospitals and demonstrates that the probability of a catastrophic failure of the required sprinkler system is remote. The biggest influence on the automatic sprinkler performance is the fire services for a properly designed, installed and maintained sprinkler system.

SMOKE DAMPER EVALUATION – ADDITIONAL CONSIDERATIONS

This portion of the reason statement evaluates an analysis prepared by Koffel Associates, Inc. (KA) titled "Smoke Damper Evaluation for Air Movement & Control Association International, Inc." and dated May 14, 2010. The purpose of our evaluation is to closely examine the details, assumptions, and conclusions related to the KA analysis to quantify the severity of hazardous conditions expected given the smoke spread predicted in the analysis for the scenarios with and without smoke dampers.

The KA analysis utilized a CONTAM computer model to predict smoke movement throughout a representative building under various conditions. The primary variables considered in this comparative analysis were whether the fire was sprinklered or unsprinklered and whether smoke dampers were included or omitted from the model. Data from a study titled "Fire Experiments of Zoned Smoke Control at the Plaza Hotel in Washington DC" by John H. Klote at the National Institute of Standards and Technology (NIST), 1990, was used as a basis for modeling smoke in the CONTAM model. Specifically, the KA analysis assumed a smoke concentration of 5.66×10^{-5} lb/ft³ in the compartment of origin for the unsprinklered fire scenario and a concentration of 1.89×10^{-6} lb/ft³ for the sprinklered fire scenario which is reportedly based on the fire test data contained in the Klote study.

The Klote study involved real fire tests conducted in the Plaza Hotel, a seven-story masonry structure. The Plaza Hotel tests were intended to evaluate the effectiveness of zoned mechanical smoke control systems. While not specified in the KA analysis, it appears that data from Plaza Hotel Test 1 and/or Test 5 was used for the unsprinklered fire scenario and data from Test 10 was used for the sprinklered fire scenario. Each of these three fire tests involved burning a 300 lb wood crib in a second floor corridor of the Plaza hotel with no mechanical smoke control systems active and all windows closed. Table 1 and Table 2 below summarize the select relevant data presented in the Klote study and KA analysis. This data shows movement away from the area of fire origin with and without smoke dampers installed in the model.

Table 1: Klote Study Results

	Tests 1 and 5	Test 10
Fuel Load	300 lb Wood Crib	300 lb Wood Crib
Test Duration	30 min	30 min
Sprinkler Interaction	No Sprinklers	Quick Response Sprinkler above Wood Crib
Peak Optical Density on Fire Floor (Fig. 24, 25)	$3 \text{ m}^{-1} @ 4 \text{ mins}^1$	$0.1 \text{ m}^{-1} @ 3 \text{ mins}$
Peak CO Concentration on Fire Floor (Fig. 21)	~6,000 ppm	~200 ppm

The maximum optical density from Tests 1 and 5 was not reported in the Klote study. This optical density value is estimated based on the CO concentrations, which show a factor of 30 differential between the sprinklered and unsprinklered fire scenarios. This factor of 30 was applied to the maximum optical density value that was reported in the sprinklered fire test (Test 10). This assumption matches the KA analysis which assumed a smoke concentration for the unsprinklered fire scenario that was approximately 30 times the sprinklered scenario.

Table 2: KA Analysis Results
Smoke Concentration on Non-Fire Floor
 (presented as % of smoke concentration on Fire Floor)

	Smoke Dampers	Without Smoke Dampers
5 Story Building @ 30 mins	1.37%	25.05%
5 Story Building @ 1 hour	2.51%	40.33%
5 Story Building @ 12 hours	7.78%	64.28%
50 Story Building @ 30 mins	0.11%	2.88%
50 Story Building @ 1 hour	0.21%	5.21%
50 Story Building @ 12 hours	0.69%	15.15%

The most severe conditions on the non-fire floor predicted by the KA analysis consider a 5 story building, no smoke dampers, and a constant smoke concentration on the fire floor over a 12-hour period. This scenario predicted that after 12 hours, the conditions on the non-fire floor, in terms of smoke concentrations, would be 64.28% of the conditions on the fire floor. After 30 minutes of constant conditions on the fire floor, the non-fire floor smoke concentration is 25.05% of that on the fire floor.

It should be noted that the assumption of constant peak smoke conditions for an extended period of time (as much as 12 hours) on the fire floor is extremely conservative. The Klote study data is based on a 30 minute test duration where the peak smoke concentrations (obscuration and CO concentrations) occur at one particular instance during the 30 minute test. Further, a fire burning at a constant rate over a 12 hour period of time would necessitate a fuel load to support such a fire. The most densely packed storage occupancies have fuel loads approaching only 3 or 4 hours.

The KA assumption is particularly conservative when considering the sprinkler controlled fire where Klote's study indicates that the fire in Test 10 was extinguished about 7 minutes after fire ignition. Klote's study also indicates that for the unsprinklered fires (Tests 1 and 5) the heat release rate of the fire decreased due to low oxygen levels after approximately 15 minutes as can be seen by the reduction in temperature shown in Figure 12 of the Klote study. So, maintaining a constant fire burning rate over a 30-minute duration is unlikely and is a very conservative assumption, especially in a building like hospitals that is occupied 24/7 by alert staff.

The following tables are intended to assess the degree of tenable conditions that may be present on the non-fire floor (for cases with and without smoke dampers) considering the referenced data from the Klote's study and the smoke concentration modeling performed in the KA analysis. The data in Table 3 is based on the CONTAM model results for the 5 story building only, which was the most challenging building configuration in terms of smoke concentrations on the non-fire floor.

Table 3: Tenability Analysis- Sprinklered Fire Scenario

Klote Test 10 (Sprinklered Fire)		
Peak Optical Density (D) on Fire Floor (Fig. 24, 25)	0.1 m ⁻¹ @ 3 mins	
Peak CO Concentration on Fire Floor (Fig. 21)	~200 ppm	
Calculated Visibility Based on Optical Density ¹	34.8 m (lighted sign)	
	With Smoke Dampers	Without Smoke Dampers
Predicted CO Concentration on Non-Fire Floor at 30 mins	200 ppm * 1.37% = 3 ppm	200 ppm * 25.05% = 50 ppm
Predicted Visibility on Non-Fire Floor at 30 mins	34.8 m / 1.37% = 2538 m	34.8 m / 25.05% = 138 m
Predicted CO Concentration on Non-Fire Floor at 1 hour	200 ppm * 2.51% = 5 ppm	200 ppm * 40.33% = 81 ppm
Predicted Visibility on Non-Fire Floor at 1 hour	34.8 m / 2.51% = 1385 m	34.8 m / 40.33% = 86 m
Predicted CO Concentration on Non-Fire Floor at 12 hours	200 ppm * 7.78% = 16 ppm	200 ppm * 64.28% = 129 ppm
Predicted Visibility on Non-Fire Floor at 12 hours	34.8 m / 7.78% = 447 m	34.8 m / 64.28% = 54 m

¹ The optical densities (D) reported in the Klote Study were converted to light extinction coefficients (K) by $K=2.3D$ and visibilities (V) were calculated to light-emitting (exit) sign by $V=8/K$.

Table 4: Tenability Analysis- Unsprinklered Fire Scenario

Klote Tests 1 and 5 Data (Unsprinklered Fire)		
Peak Optical Density (D) on Fire Floor (Fig. 24, 25)	3 m ⁻¹ @ 4 min	
Peak CO Concentration on Fire Floor (Fig. 21)	~6,000 ppm	
Calculated Visibility Based on Optical Density ¹	1.2 m (lighted sign)	
	With Smoke Dampers	Without Smoke Dampers
Predicted CO Concentration on Non-Fire Floor at 30 mins	6,000 ppm * 1.37% = 83 ppm	6,000 ppm * 25.05% = 1503 ppm
Predicted Visibility on Non-Fire Floor at 30 mins	1.2 m / 1.37% = 84.7 m	1.2 m / 25.05% = 4.6 m
Predicted CO Concentration on Non-Fire Floor at 1 hour	6,000 ppm * 2.51% = 151 ppm	6,000 ppm * 40.33% = 2420 ppm
Predicted Visibility on Non-Fire Floor at 1 hour	1.2 m / 2.51% = 46.2 m	1.2 m / 40.33% = 2.9 m
Predicted CO Concentration on Non-Fire Floor at 12 hour	6,000 ppm * 7.78% = 467 ppm	6,000 ppm * 64.28% = 3857 ppm
Predicted Visibility on Non-Fire Floor at 12 hour	1.2 m / 7.78% = 14.9 m	1.2 m / 64.28% = 1.8 m

¹ The optical densities (D) reported in the Klote Study were converted to light extinction coefficients (K) by $K=2.3D$ and visibilities (V) were calculated to light-emitting (exit) sign by $V=8/K$.

The KA analysis discusses tenability on the non-fire floor in terms of visibility through smoke. A tenability performance criterion of approximately 10 meters (30 feet) is cited by the KA analysis as a commonly used value. While this visibility criterion is within ranges of visibility criteria for general building applications presented by The SFPE Handbook, 4th edition (Section 2, Chapter 4) Table 2-4.3, a lower criterion of 4 meters is suggested for healthcare occupancies where patients and staff are familiar with their surroundings and egress paths are typically defined by small rooms and corridors as opposed to large open

spaces where greater visibility is necessary. Table 2-4.2 of the SFPE Handbook suggest a visibility threshold of 4 meters to allow safe escape when occupants are familiar with their surroundings.

Although not referenced in the KA analysis, tenability is also often measured in terms of carbon monoxide (CO) concentrations. CO is a measure of the toxicity of smoke that occupants are exposed to during evacuation. Carbon monoxide (CO) causes the formation of carboxyhemoglobin in the bloodstream when it is being breathed in the air during exposure. This relationship between exposure time and the concentration of carbon monoxide is dynamic, varying based upon the varying concentrations of CO within the surroundings and the physical condition of the individual. A more detailed discussion of the formation of carboxyhemoglobin can be found in the SFPE Handbook, 4th edition (Section 2, Chapter 6). Figure 2-6.14 of the SFPE Handbook indicates that occupant exposure with an at rest respiratory rate to a carbon monoxide concentration of 2,000 parts per million (ppm) can be experienced for 30 minutes before incapacitation occurs. Based on this relationship between exposure time and concentration, a conservative tenability criterion for carbon monoxide concentrations of 2000 ppm is suggested.

Based on the tenability criteria of 4 meters for visibility and 2000 ppm for CO concentrations, the data in the Klote study for the sprinklered fire indicates that conditions were tenable on the fire floor during the 30 minute fire test as the minimum visibility was measured to be 34.8 meters to a lighted exit sign and a maximum CO concentration of approximately 200 ppm. If the conditions on the fire floor are tenable, then any lower concentrations of smoke on non-fire floors, as predicted by the KA analysis, will also be tenable. This suggests that for sprinkler controlled fires, tenable conditions will be maintained on the non-fire floor, regardless of whether smoke dampers are installed, when considering the assumptions contained in the KA analysis. This is further supported by a study performed by Notarianni, "Measurement of Room Conditions and Response of Sprinklers and Smoke Detectors During a Simulated Two-Bed Hospital Patient Room Fire", NISTIR 5240, 1993 which assessed performance of sprinklers and smoke detectors in typical hospital room configurations. This study concluded that in all tests, with one exception, the sprinklers actuated in the room of fire origin before the patient's life would be threatened. The one exception was the shielded fire test where the sprinklers activated after untenable conditions were reached in the patient room. This study supports the assertion that in most cases sprinklers will activate and control further growth of the fire before untenable conditions are reached in the room of origin. Therefore, the sprinklers help to control the spread of untenable conditions throughout the building.

The results of for the unsprinklered fire scenario in Table 4 above show a minimum visibility on the non-fire floor of 4.6 meters to a lighted exit sign and a maximum CO concentration of 1503 ppm after 30 minutes of constant peak conditions on the fire floor. Based on the tenability criteria cited above of at least 4 meters of visibility and a maximum CO concentration of 2000 ppm, the conditions after 30 minutes for the unsprinklered fire scenario can also be considered tenable. It should be noted that the lowest visibility conditions in the Klote study occurred no earlier than 4 minutes after fire ignition and the maximum CO concentrations occurred no earlier than 15 minutes after fire ignition. The KA analysis for the 30 minute exposure assumes these most severe conditions on the fire floor from fire ignition (time zero) which indicates that tenable conditions should be maintained on the non-fire floor for more than 30 minutes after fire ignition when considering the delay in the Klote tests from ignition to when the most severe conditions occur in on the fire floor.

For the 1991 edition of NFPA 101, the Subcommittee on Health Care Occupancies performed studies that evaluated the benefits of healthcare occupancies when provided with a fully automatic sprinkler system and quick response sprinkler heads. All new Group I-2 buildings are required to be provided with a fully automatic sprinkler system and QRS. The studies discussed and mentioned above provide further scientific documentation that sprinklers are a more than effective means of mitigating the transfer of smoke beyond smoke compartment walls, as was discussed over twenty years ago.

Additionally, the requirements for interior finishes, decorative materials, mattresses, upholstered furniture, decorative vegetation and other decorative furnishings have become more restrictive in the past twenty years as well. Test standards have been developed to further quantify statistical information regarding the flame spread and smoke development of each of these above items. With these added restrictions within Group I-2 occupancies, the flame spread and smoke development ratings of these have assisted in the reduction of a greater potential event.

This review and analysis of previous fire tests, studies, and performance data provides a basis for justification to omit smoke dampers in new I-2 healthcare facilities. The performance of a building without automatic sprinkler protection has many variables to consider. The analysis above does look at typical non sprinklered scenarios and shows acceptable performance for at least the first 30 minutes. Emergency responders will be on site to assist the staff in a fire response. The recent fire records in healthcare facilities both sprinklered and non sprinklered show an ability to protect the person not intimate with a fire.

Bibliography

- (1) *U.S. Experience with Sprinklers and Other Automatic Fire Extinguishing Equipment*, John R. Hall, Jr. P.E. PhD, National Fire Protection Association, 2010
- (2) *Structure Fires in Medical, Mental Health, and Substance Abuse Facilities*; Jennifer D. Flynn; National Fire Protection Association; February 2009

Cost Impact: The code change proposal will reduce the cost of construction and will eliminate on-going maintenance costs.

FS114-12

Public Hearing:	Committee:	AS	AM	D
	Assembly:	ASF	AMF	DF

717.5.5-FS-Williams-AdHocHealthcare

FS115 – 12
717.6.2.1 (IMC 607.6.2.1)

Proponent: Bob Eugene, representing Underwriters Laboratories (Robert.Eugene@ul.com)

Revise as follows:

717.6.2.1 (IMC 607.6.2.1) Ceiling radiation dampers. *Ceiling radiation dampers* shall be tested in accordance with Section 717.3.1. *Ceiling radiation dampers* shall be installed in accordance with the details *listed* in the fire-resistance-rated assembly and the manufacturer's installation instructions and the listing. *Ceiling radiation dampers* are not required where ~~either~~ one of the following applies:

1. Tests in accordance with ASTM E 119 or UL 263 have shown that *ceiling radiation dampers* are not necessary in order to maintain the *fire-resistance rating* of the assembly.
2. Where exhaust duct penetrations are protected in accordance with Section 714.4.1.2, are located within the cavity of a wall and do not pass through another *dwelling unit* or tenant space.
3. Where duct and air transfer openings are protected with a duct outlet protection system tested as part of a fire-resistance-rated assembly in accordance with ASTM E 119 or UL 263.

Reason: This proposal is intended to permit the use of duct protection methods other than ceiling radiation dampers for protecting ducts and air transfer openings through the ceiling membrane of a fire-resistance-rated floor/ceiling or roof/ceiling assembly. The acceptance of the alternate duct protection systems is based on testing conducted in accordance with ASTM E 119 or UL 263. Although one could argue use the current Provision No. 1 of Section 717.6.2.1 to rationalize the use of alternate duct protection methods, this proposal makes it clear that alternate methods are permitted based on testing. Example of alternate protection methods include insulation and wrap materials.

Cost Impact: None

FS115-12

Public Hearing:	Committee:	AS	AM	D
	Assembly:	ASF	AMF	DF

717.6.2.1-FS-EUGENE

FS116 – 12

717.6.3 (IMC 607.6.3)

Proponent: Guy McMann MCP, Jefferson County Colorado, representing Colorado Association of Plumbing and Mechanical Officials (CAPMO) (gmcmann@jeffco.us)

Revise as follows:

717.6.3 (IMC 607.6.3) Nonfire-resistance-rated floor assemblies. Duct systems constructed of *approved* materials in accordance with the *International Mechanical Code* that penetrate nonfire-resistance-rated floor assemblies shall be protected by any of the following methods:

1. A shaft enclosure in accordance with Section 713.
2. The duct connects not more than two *stories*, and the *annular space* around the penetrating duct is protected with an *approved* noncombustible material that resists the free passage of flame and the products of combustion.
3. ~~The duct connects not more than three stories, and the annular space around the penetrating duct is protected with an approved noncombustible material that resists the free passage of flame and the products of combustion and a fire damper is installed at each floor line.~~

~~**Exception:** Fire dampers are not required in ducts within individual residential dwelling units.~~

Reason: This text is in conflict with where fire-dampers are to be installed. Fire dampers are not tested or listed to be installed in this application. This is an apparent cost saving measure in an attempt to circumvent the requirements for shafting by installing fire-dampers in wood floors. The code has stood on the cherished principle that materials and products be installed in accordance with the manufacturer's instructions and the listings but in this case there are no instructions or listings to install the product. Code enforcement is placed in an awkward position to permit installations that violate listings. There needs to be other language installed in the code that achieves the desired outcome without resorting to violating listings. This is an inappropriate use of a product and it's difficult to defend the practice. A companion change has been submitted to the IMC committee

Cost Impact: None

FS116-12

Public Hearing:	Committee:	AS	AM	D
	Assembly:	ASF	AMF	DF

717.6.3-FS-MCMANN

FS117 – 12

716.7 (IMC 607.7), 716.7.1 (IMC 607.7.1 (New))

Proponent: Umesh Kumar Bhargava, PE., Bhargava International, Inc., representing self

Add new text as follows:

717.7 (IMC 607.7) Flexible ducts and air connectors. Flexible ducts and air connectors shall not pass through any fire-resistance-rated assembly. Flexible air connectors shall not pass through any wall, floor or ceiling.

717.7.1 (IMC 607.7.1) Length of metallic duct. The minimum length and minimum thickness of metallic duct on either side of the any wall, floor or ceiling shall be 36 inches (914 mm) and 20 gauge, respectively.

Reasons: Current code does not provide guidance regarding length of the metallic duct on either side of fire rated assembly. Metallic duct will protect fire characteristic of fire rated assembly. This is similar to opening are not permitted within fire rated walls and rated demising walls.

Cost Impact: None

FS117-12

Public Hearing:	Committee:	AS	AM	D
	Assembly:	ASF	AMF	DF

716.7-FS-BHARGAVA

FS118 – 12

717.8 (New) [IMC 607.8 (New)]

Proponent: Timothy Burgos, InterCode Incorporated, representing 3M Company

Add new text as follows:

717.8 (IMC 607.8) Reflective Ducts. Reflective ducts that are designed and installed to provide light to the interior space of a building shall be constructed, braced, reinforced and installed to provide structural strength and durability in accordance with the requirements of Section 608 of the *International Mechanical Code*. The installation of reflective ducts shall not affect the fire protection requirements specified in this code. Reflective ducts shall not be used for conveying air and are not required to be pressurized.

Reason: The purpose of this code change proposal is to add a new section to the International Building Code in order to differentiate between duct used to convey air and duct used to convey light. There are many new technologies that exist worldwide today that bring light from the exterior of a building to the interior space of a building. These technologies utilize a reflective duct to convey the light into the building. The reflective duct is similar in construction to duct used to convey air in the way it is braced, reinforced, and installed. Reflective duct differs because it is not used to condition a space. Additionally, reflective duct does not need to meet all the requirements of an air conveying duct, i.e. the insulation and pressurization requirements.

The language used to create the new Section 717.8 was adapted from Section 603 of the 2012 International Mechanical Code.



Reflective duct (the two ducts on the outside) in an open ceiling alongside a traditional HVAC duct.

Cost Impact: The code change proposal will not increase the cost of construction.

FS118-12

Public Hearing:	Committee:	AS	AM	D
	Assembly:	ASF	AMF	DF

717.8 (NEW)-FS-BURGOS

FS119 – 12

718.2.1

Proponent: Tony Crimi, A.C. Consulting Solutions Inc, representing North American Insulation Manufacturers Association (NAIMA) (tcrimi@sympatico.ca)

Revise as follows:

718.2.1 Fireblocking materials. *Fireblocking* shall consist of the following materials:

1. Two-inch (51 mm) nominal lumber.
2. Two thicknesses of 1-inch (25 mm) nominal lumber with broken lap joints.
3. One thickness of 0.719-inch (18.3 mm) wood structural panels with joints backed by 0.719-inch (18.3 mm) wood structural panels.
4. One thickness of 0.75-inch (19.1 mm) particleboard with joints backed by 0.75-inch (19 mm) particleboard.
5. One-half-inch (12.7 mm) gypsum board.
6. One-fourth-inch (6.4 mm) cement-based millboard.
7. Batts or blankets of *mineral wool*, *mineral fiber* or other *approved* materials installed in such a manner as to be securely retained in place.
8. Cellulose insulation installed as tested in accordance with ASTM E119 or UL 263, for the specific application.

Reason: This proposals clarifies the code requirement and prevents potentially unintended test methods from being used for these purposes. The proposal aims to provide more detail to the requirement to test cellulose insulation in accordance with the appropriate fire test standards. During the last cycle, FS118-09/10 added spray-applied cellulose to the list of acceptable fireblocking materials. The proponents statement does identify ASTM E119 as the test standard used by the Cellulose Insulation Manufacturers Association (CIMA) to conduct a variety of fireblocking fire tests.

Cost Impact: This proposal will not increase the cost of construction.

FS119-12

Public Hearing:	Committee:	AS	AM	D
	Assembly:	ASF	AMF	DF

718.2.1-FS-CRIMI

FS120 – 12

720.2, 720.3, 720.4, 720.6

Proponent: Rick Thornberry, P.E. representing the Cellulose Insulation Manufacturers Association (CIMA)

Revise as follows:

720.2 Concealed insulation. Insulating materials, where concealed as installed in buildings of any type of construction, shall have a flame spread index of not more than 25 and a smoke-developed index of not more than 450.

Exception: ~~Cellulose~~ Cellulosic fiber loose-fill insulation ~~that is not spray applied~~, complying with the requirements of Section 720.6; shall only be required to meet the smoke-developed index of not more than 450.

720.3 Exposed insulation. Insulating materials, where exposed as installed in buildings of any type of construction, shall have a flame spread index of not more than 25 and a smoke-developed index of not more than 450.

Exception: ~~Cellulose~~ Cellulosic fiber loose-fill insulation ~~that is not spray applied~~ complying with the requirements of Section 720.6 shall only be required to meet the smoke-developed index of not more than 450.

720.4 Loose-fill insulation. Loose-fill insulation materials that cannot be mounted in the ASTM E 84 or UL 723 apparatus without a screen or artificial supports shall comply with the flame spread and smoke-developed limits of Sections 720.2 and 720.3 when tested in accordance with CAN/ULC S102.2.

Exception: ~~Cellulose~~ Cellulosic fiber loose-fill insulation shall not be required to be tested in accordance with CAN/ULC S102.2, provided such insulation has a smoke-developed index of not more than 450 and complies with the requirements of ~~Section 720.2 or 720.3, as applicable, and~~ Section 720.6.

720.6 ~~Cellulose~~ Cellulosic fiber loose-fill insulation and self-supported spray applied cellulosic insulation. ~~Cellulose~~ Cellulosic fiber loose-fill insulation and self-supported spray applied cellulosic insulation shall comply with CPSC 16 CFR Parts 1209 and ~~CPSC 16 CFR Part~~ 1404. Each package of such insulating material shall be clearly labeled in accordance with CPSC 16 CFR Parts 1209 and ~~CPSC 16 CFR Part~~ 1404.

Reason: The purpose of this code change proposal is to clarify the requirements for cellulose insulation by substituting the industry terms for the two types of cellulose insulation commonly used: cellulosic fiber loose-fill insulation and self-supported spray applied cellulosic insulation. These two terms are taken from ASTM C 739, Standard Specification for Cellulosic Fiber Loose-Fill Thermal Insulation and ASTM C 1149, Standard Specification for Self-Supported Spray Applied Cellulosic Thermal Insulation, respectively. The application of the Exception to Section 720.4 is also simplified and made more user friendly by including the smoke-developed index requirement and deleting the references to Sections 720.2 and 720.3 where that requirement is specified by the Exceptions to those sections. This saves the code user a step in the process of applying Section 720.4 and avoids potential misapplications and misinterpretations that often occur when dealing with multiple Exceptions.

Cost Impact: The code change proposal will not increase the cost of construction.

FS120-12

Public Hearing:	Committee:	AS	AM	D
	Assembly:	ASF	AMF	DF

720.2-FS-THORNBERRY

FS121 – 12

720.2, 720.3, 720.4

Proponent: Marcelo M Hirschler, GBH International (gbhint@aol.com)

Revise as follows:

720.2 Concealed installation. Insulating materials, where concealed as installed in buildings of any type of construction, shall have a flame spread index of not more than 25 and a smoke-developed index of not more than 450.

Exception: Cellulose loose-fill insulation that is not spray applied, complying with the requirements of Section 720.6, shall not be required to meet a flame spread index requirement but shall only be required to meet a the smoke-developed index of not more than 450 when tested in accordance with CAN/ULC S102.2.

720.3 Exposed installation. Insulating materials, where exposed as installed in buildings of any type of construction, shall have a flame spread index of not more than 25 and a smoke-developed index of not more than 450.

Exception: Cellulose loose-fill insulation that is not spray applied, complying with the requirements of Section 720.6, shall not be required to meet a flame spread index requirement but shall only be required to meet a the smoke-developed index of not more than 450 when tested in accordance with CAN/ULC S102.2.

720.4 Loose-fill insulation. Loose-fill insulation materials that cannot be mounted in the ASTM E 84 or UL 723 apparatus without a screen or artificial supports shall comply with the flame spread and smoke-developed limits of Sections 720.2 and 720.3 when tested in accordance with CAN/ULC S102.2.

Exception: Cellulose loose-fill insulation shall not be required to meet a flame spread index requirement when be tested in accordance with CAN/ULC S102.2, provided such insulation complies with the requirements of Section 720.2 or 720.3, as applicable, and Section 720.6.

Reason: Recent discussions have shown that cellulose loose fill insulation is actually tested in the ASTM E84 test by using an artificial steel screen with tiny grid openings such that the flame spread index determined is meaningless because of the massive effect of the metal included with the loose fill insulation. Unless that screen is used the cellulose loose fill insulation falls through the grid onto the tunnel floor. The IBC (and the IRC) have long ceased to require that cellulose loose fill insulation meets a flame spread index criterion (if it complies with the CPSC requirements in 16 CFR 1209 and 16 CFR 1404, i.e. smoldering tests) but only that the insulation meets a smoke developed index. There is consensus in the fire test community that if the flame spread index cannot be determined adequately with the ASTM E84 test using that steel screen, neither can the smoke developed index be determined. Therefore, the recommendation is that the tests be conducted in accordance with CAN/ULC S102.2 and not ASTM E84, where no metal screen is needed since the loose fill insulation material is tested on the floor and not on the ceiling.

Usually cellulose loose fill insulation will meet the appropriate smoke developed index values but the appropriate fire test needs to be used.

Language in ASTM E84:

X1.6.1 Loose-fill insulation shall be placed on galvanized steel screening (Note 11) with approximate 3/64-in. (1.2-mm) openings supported on a test frame 20 in. (508 mm) wide by 2 in. (51 mm) deep, made from 2 by 3 by 3/16-in. (51 by 76 by 5-mm) steel angles (see Fig. X1.2). Three frames are required to cover the full tunnel length. The insulation shall be packed to the density specified by the manufacturer.

Note 11: The use of galvanized steel screening normally lowers the flame spread index values obtained for some materials that are tested in this manner and, therefore, the results do not necessarily relate directly to values obtained for other materials mounted without galvanized steel screening.

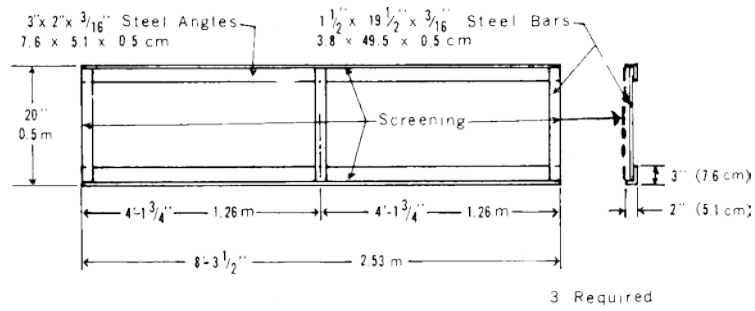

FIG. X1.2 Steel Frame for Loose Fill Materials

Cost Impact: None

FS121-12

Public Hearing: Committee: AS AM D
 Assembly: ASF AMF DF

720.2-FS-HIRSCHLER

FS122 – 12
Table 721.1(3)

Proponent: Sam Francis, American Wood Council (sfrancis@awc.org)

Revise as follows:

TABLE 721.1(3)
MINIMUM PROTECTION FOR FLOOR AND ROOF SYSTEMS^{a, q}

FLOOR OR ROOF CONSTRUCTION	ITEM NUMBER	CEILING CONSTRUCTION	THICKNESS OF FLOOR OR ROOF SLAB (inches)				MINIMUM THICKNESS OF CEILING (inches)			
			4 hr	3 hr	2 hr	1 hr	4 hr	3 hr	2 hr	1 hr
23. Wood I-joist (minimum joist depth 9-1/4" with a minimum flange depth of 1-5/16" and a minimum flange cross-sectional area of 2.25 square inches) at 24" o.c. spacing with 4" by 4 inch (nominal) a minimum 1x4 (3/4" x 3.5" actual) wood furring strip spacer ledger strip applied parallel to and covering the bottom of the bottom flange of each member, tacked in place. 2" mineral wool insulation, 3.5 pcf (nominal) installed adjacent to the bottom flange of the I-joist and supported by the 1"x4" furring strip spacer 1x4 ledger strip.	23-1.1	1/2" deep single leg resilient channel 16" on center (channels doubled at wallboard end joints), placed perpendicular to the furring strip and joist and attached to each joist by 1-7/8" Type S drywall screws, 5/8" Type C gypsum wallboard applied perpendicular to the channel with end joints staggered at least 4' and fastened with 1-1/8" Type S drywall screws spaced 7" on center. Wallboard joints to be taped and covered with joint compound.	—	—	—	Varies	—	—	—	5/8
27. Wood I-joist (minimum I-joist depth 9-1/2" with a minimum flange depth of 1-15/16" and a minimum flange cross-sectional area of 1.95 square inches; minimum web thickness of 3/8") @ 24" o.c.	27-1.1	Minimum 0.019" thick resilient channel 16" o.c. (Channels doubled at wallboard end joints), placed perpendicular to the joists and attached to each joist by 1-5/8" 1-1/4" Type S drywall screws. Two Layers of 1/2" Type X gypsum wallboard applied with the long dimension perpendicular to the I-joists with end joints staggered. The base layer is fastened with 1-1/4" Type S drywall screws spaced 12" o.c. and the face layer is fastened with 1-5/8" Type S drywall screws spaced 12" o.c. Face layer end joints shall not occur on the same I-joist as base layer end joints and edge joints shall be offset 24" from base layer joints. Face layer to also be attached to base layer with 1-1/2" Type G drywall screws spaced 8" o.c. placed 6" from face layer end joints. Face layer wallboard joints to be taped and covered with joint compound.	—	—	—	Varies	—	—	—	1

(Portions of table not shown remain unchanged)

Reason: The changes proposed here are editorial. The original publication of this entry contained typographical errors such as rounding the minimum flange cross-sectional area to 2.3 cubic inches from the original submitted text of 2.25 cubic inches. Other changes are simply to clean up language involving nominal dimension or actual dimension and other nontechnical issues. In Item 27, the minimum required length of the drywall screws was incorrectly entered as 1-5/8inch when the actual minimum is 1-1/4inch.

On the following pages, WIJ-1.3 is the information from AWC, including the test report reference, for item #23 and WIJ-1.6 is the information for item #27 in the table.

WIJ-1.3 One-Hour Fire-Resistive Ceiling Assembly

Floor/Ceiling - 100% Design Load - 1 Hour Rating - ASTM E 119 / NFPA 251

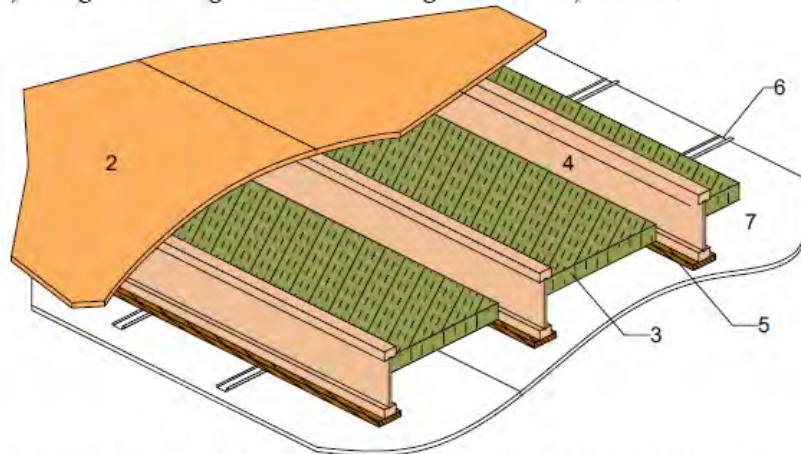

1. **Floor Topping (optional, not shown):** Gypsum concrete, lightweight or normal concrete topping.
2. **Floor Sheathing:** Minimum 23/32 inch thick tongue-and-groove wood sheathing (Exposure 1). Installed per code requirements.
3. **Insulation:** Minimum 2 inch thick mineral wool insulation batts – 3.5 pcf (nominal), supported by setting strip edges, friction-fitted between the sides of the I-joist flanges.
4. **Structural Members:** Wood I-joists spaced a maximum of 24 inches on center.
 Minimum I-joist flange depth: 1-5/16 inches Minimum I-joist flange area: 2.25 inches²
 Minimum I-joist web thickness: 3/8 inch Minimum I-joist depth: 9-1/4 inches
 See ASTM D 5055-07 for qualification requirements.
5. **Setting Strips:** Minimum 1x4 (nominal) wood setting strips attached with 1-1/2 inch long drywall screws at 24 inches on center along the bottom flange of I-joist creating a ledge to support insulation.
6. **Resilient Channels:** Minimum 0.019 inch thick galvanized steel resilient channels, attached perpendicular to I-joists using 1-7/8 inch long drywall screws. Resilient channels spaced 16 inches on center and doubled at each wallboard end joint extending to the next joist.
7. **Gypsum Wallboard:** Minimum 5/8 inch thick Type C gypsum wallboard installed with long dimension perpendicular to resilient channels and fastened to each channel with minimum 1-1/8 inch long Type S drywall screws. Fasteners spaced 7 inches on center and 3/4 inches from panel edges and ends. End joints of wallboard staggered.
7. **Finish System (not shown):** Face layer joints covered with tape and coated with joint compound. Screw heads covered with joint compound.

Fire Test conducted at National Gypsum Testing Services, Inc.
 Third Party Witness: Underwriter’s Laboratories, Inc.

September 28, 2001
 Report No: NC3369

STC and IIC Sound Ratings for Listed Assembly							
Without Gypsum Concrete				With Gypsum Concrete			
Cushioned Vinyl		Carpet & Pad		Cushioned Vinyl		Carpet & Pad	
STC	IIC	STC	IIC	STC	IIC	STC	IIC
51 ^b	46 ^b	52	66	60 ^b	48 ^b	60 ^b	60 ^b

^a This assembly may also be used in a fire-rated roof/ceiling application, but only when constructed exactly as described.

^b STC and IIC values estimated by David L. Adams Associates, Inc

WIJ-1.6 One-Hour Fire-Resistive Ceiling Assembly

Floor³/Ceiling - 100% Design Load - 1 Hour Rating - ASTM E 119 / NFPA 251

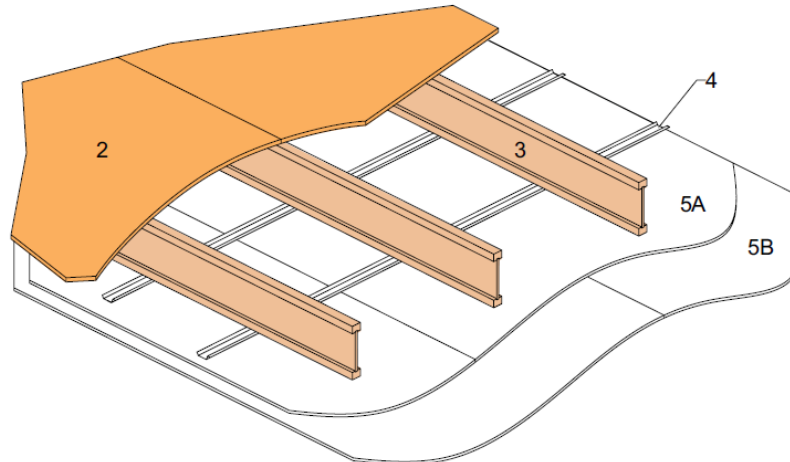

1. **Floor Topping (optional, not shown):** Gypsum concrete, lightweight or normal concrete topping.
2. **Floor Sheathing:** Minimum 23/32 inch thick tongue-and-groove wood sheathing (Exposure 1). Installed per code requirements with minimum 8d common nails.
3. **Structural Members:** Wood I-joists spaced a maximum of 24 inches on center.
 Minimum I-joist flange depth: 1-5/16 inches Minimum I-joist flange area: 2.25 inches²
 Minimum I-joist web thickness: 3/8 inch Minimum I-joist depth: 9-1/2 inches
 See ASTM D 5055-07 for qualification requirements.
4. **Resilient Channels^b:** Minimum 0.019 inch thick galvanized steel resilient channel attached perpendicular to the bottom flange of the I-joists with one 1-1/4 inch drywall screw. Channels spaced a maximum of 16 inches on center [24 inches on center when I-joists are spaced a maximum of 16 inches on center].
5. **Gypsum Wallboard:** Two layers of minimum 1/2 inch Type X gypsum wallboard attached with the long dimension perpendicular to the resilient channels as follows:
 - 5a. **Wallboard Base Layer:** Base layer of wallboard attached to resilient channels using 1-1/4 inch Type S drywall screws at 12 inches on center.
 - 5b. **Wallboard Face Layer:** Face layer of wallboard attached to resilient channels through base layer using 1-5/8 inch Type S drywall screws spaced 12 inches on center. Edge joints of wallboard face layer offset 24 inches from those of base layer. Additionally, wallboard face layer attached to base layer with 1-1/2 inch Type G drywall screws spaced 8 inches on center, placed 1-1/2 inches from face layer end joints.
6. **Finish System (not shown):** Face layer joints covered with tape and coated with joint compound. Screw heads covered with joint compound.

Fire Test conducted at National Research Council of Canada Report No. A-4440.1 June 24, 1997

STC and IIC Sound Ratings for Listed Assembly							
Without Gypsum Concrete				With Gypsum Concrete			
Cushioned Vinyl		Carpet & Pad		Cushioned Vinyl		Carpet & Pad	
STC	IIC	STC	IIC	STC	IIC	STC	IIC
-	-	54	68	-	-	58 ^c	55 ^c

^a This assembly may also be used in a fire-rated roof/ceiling application, but only when constructed exactly as described.
^b Direct attachment of gypsum wallboard in lieu of attachment to resilient channels is typically deemed acceptable. When gypsum wallboard is directly attached to the I-joists, the wallboard should be installed with long dimension perpendicular to the I-joists and sound ratings for WIJ-1.5 should be used.
^c STC and IIC values estimated by David L. Adams Associates, Inc

Copyright © 2010
 American Wood Council

January 2009

Cost Impact: The code change proposal will not increase the cost of construction.

FS122-12

Public Hearing: Committee: AS AM D
 Assembly: ASF AMF DF

T721.1(3) #1-FS-FRANCIS

FS123 – 12

Table 721.1(3)

Proponent: Tony Crimi, A.C. Consulting Solutions Inc, representing North American Insulation Manufacturers Association (NAIMA) (tcrimi@sympatico.ca)

Revise as follows:

TABLE 721.1(3)
MINIMUM PROTECTION FOR FLOOR AND ROOF SYSTEMS^{a, q}

FLOOR OR ROOF CONSTRUCTION	ITEM NUMBER	CEILING CONSTRUCTION	THICKNESS OF FLOOR OR ROOF SLAB (inches)				THICKNESS OF FLOOR OR CEILING (inches)			
			4 hours	3 hours	2 hours	1 hours	4 hours	3 hours	2 hours	1 hours
28. Wood I-joint (minimum I-joint depth 91/4" with a minimum flange depth of 11/2" and a minimum flange cross-sectional area of 2.25 square inches; minimum web thickness of 3/8") @ 24" o.c. Unfaced fiberglass insulation or mineral wool insulation is installed between the joists supported on the upper surface of the flange by stay wires spaced 12" o.c.	28-1.1	Base layer of 3/8" Type C gypsum wall-board attached directly to I-joists with 1 3/8" Type S drywall screws spaced 12" o.c. with ends staggered. Minimum 0.0179" thick hat-shaped 7/8" -inch furring channel 16" o.c. (channels doubled at wallboard end joints), placed perpendicular to the joist and attached to each joist by 1 5/8" Type S drywall screws after the base layer of gypsum wall-board has been applied. The middle and face layers of 3/8" Type C gypsum wall-board applied perpendicular to the channel with end joints staggered. The middle layer is fastened with 1" Type S drywall screws spaced 12" o.c. The face layer is applied parallel to the middle layer but with the edge joints offset 24" from those of the middle layer and	—	—	—	Varies	—	—	2 3/4	—

FLOOR OR ROOF CONSTRUCTION	ITEM NUMBER	CEILING CONSTRUCTION	THICKNESS OF FLOOR OR ROOF SLAB (inches)				THICKNESS OF FLOOR OR CEILING (inches)			
			4 hours	3 hours	2 hours	1 hours	4 hours	3 hours	2 hours	1 hours
		fastened with 1 ⁵ / ₈ " Type S drywall screws 8" o.c. The joints shall be taped and covered with joint compound.								

(Portions of table not shown remain unchanged)

Reason: The IBC treats glass fiber insulation and mineral wool insulation as interchangeable in parallel in most applications in this Table. This particular assembly in Section 721 does not identify miner fiber insulation as being permitted. Since mineral wool insulation performs at least as well as glass fiber insulation under fire conditions, it should be added to this design.

Cost Impact: This proposal should not increase the cost of construction.

FS123-12

Public Hearing: Committee: AS AM D
Assembly: ASF AMF DF

T721.1(3)-FS-CRIMI

FS124 – 12
Table 721.1(3)

Proponent: Sam Francis, American Wood Council (sfrancis@awc.org)

Revise as follows:

TABLE 721.1(3)
MINIMUM PROTECTION FOR FLOOR AND ROOF SYSTEMS^{a, q}

FLOOR OR ROOF CONSTRUCTION	ITEM NUMBER	CEILING CONSTRUCTION	THICKNESS OF FLOOR OR ROOF SLAB (inches)				MINIMUM THICKNESS OF CEILING (inches)			
			4 hr	3 hr	2 hr	1 hr	4 hr	3 hr	2 hr	1 hr
30. Wood I-joist (minimum I-joist depth 9-1/2" with a minimum flange depth of 1-1/2" and a minimum flange cross-sectional area of 2.25 square inches; minimum web thickness of 3/8") @ 24" o.c. Fiberglass insulation placed between I-joists supported by the resilient channels.	30-1.1	Minimum 0.019" thick resilient channel 16" o.c. (Channels doubled at wallboard end joints), placed perpendicular to the joists and attached to each joist by 1-1/4" Type S drywall screws. Two Layers of 1/2" Type X gypsum wallboard applied with the long dimension perpendicular to the I-joists with end joints staggered. The base layer is fastened with 1-1/4" Type S drywall screws spaced 12" o.c. and the face layer is fastened with 1-5/8" Type S drywall screws spaced 12" o.c. Face layer end joints shall not occur on the same I-joist as base layer end joints and edge joints shall be offset 24" from base layer joints. Face layer to also be attached to base layer with 1-1/2" Type G drywall screws spaced 8" o.c. placed 6" from face layer end joints. Face layer wallboard joints to be taped and covered with joint compound.	=	=	=	Varies	=	=	=	1

(Portions of table not shown remain unchanged)

Reason: Many code officials have come to rely upon Table 721 as the preferred source of information regarding fire resistance rated assemblies. Because of its importance, we believe that the table should offer the most common generic assemblies. Floor systems utilizing I-joists have increased from less than 10 percent in 1990 to more than 50 percent. With the increased prevalence of I-joist floor/ceiling assemblies, including this assembly in the table will make the IBC more complete and it will be more useful to code officials. It is also expected that the document will be "user friendly", particularly for designers. In an effort to fulfill this expectation, we propose this common assembly for incorporation into Table 721.1(3). It is supported by ASTM E-119 test results as shown on the attached page. The following information and test results are provided with the understanding that their inclusion does not place them within the copyright release requirements of the signature statement.

WIJ-1.7 One-Hour Fire-Resistive Ceiling Assembly

Floor²/Ceiling - 100% Design Load - 1 Hour Rating - ASTM E 119 / NFPA 251

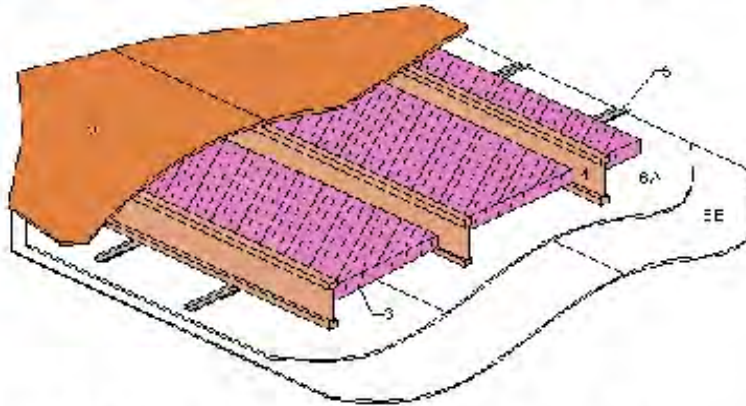

1. **Floor Topping (optional, not shown):** Gypsum concrete, lightweight or normal concrete topping.
2. **Floor Sheathing:** Minimum 23/32 inch thick tongue-and-groove wood sheathing (Exposure 1). Installed per code requirements with minimum 8d common nails.
3. **Insulation:** Fiberglass insulation placed between I-joists supported by the resilient channels.
4. **Structural Members:** Wood I-joists spaced a maximum of 24 inches on center.
 - Minimum I-joist flange depth: 1-1/2 inches
 - Minimum I-joist web thickness: 3/8 inch
 - Minimum I-joist flange area: 2.25 inches²
 - Minimum I-joist depth: 9-1/2 inches

See ASTM D 5055-07 for qualification requirements.

5. **Resilient Channels:** Minimum 0.019 inch thick galvanized steel resilient channel attached perpendicular to the bottom flange of the I-joists with one 1-1/4 inch drywall screw. Channels spaced a maximum of 16 inches on center [24 inches on center when I-joists are spaced a maximum of 16 inches on center].
6. **Gypsum Wallboard:** Two layers of minimum 1/2 inch Type X gypsum wallboard attached with the long dimension perpendicular to the resilient channels as follows:
 - 6a. **Wallboard Base Layer:** Base layer of wallboard attached to resilient channels using 1-1/4 inch Type S drywall screws at 12 inches on center.
 - 6b. **Wallboard Face Layer:** Face layer of wallboard attached to resilient channels through base layer using 1-5/8 inch Type S drywall screws spaced 12 inches on center. Edge joints of wallboard face layer offset 24 inches from those of base layer. Additionally, wallboard face layer attached to base layer with 1-1/2 inch Type G drywall screws spaced 8 inches on center, placed 1-1/2 inches from face layer end joints.
7. **Finish System (not shown):** Face layer joints covered with tape and coated with joint compound. Screw heads covered with joint compound.

Fire Test conducted at National Research Council of Canada

Report No: A-4219.13.2

March 23, 1998

STC and IIC Sound Ratings for Listed Assembly							
Without Gypsum Concrete				With Gypsum Concrete			
Cushioned Vinyl		Carpet & Pad		Cushioned Vinyl		Carpet & Pad	
STC	IIC	STC	IIC	STC	IIC	STC	IIC
59	50	55 ^b	68 ^b	65	51	63 ^b	65 ^b

^a This assembly may also be used in a fire-rated roof/ceiling application, but only when constructed exactly as described.

^b STC and IIC values estimated by David L. Adams Associates, Inc.

AMERICAN WOOD COUNCIL

Copyright © 2002, 2007, 2009
AMERICAN FOREST & PAPER ASSOCIATION, INC

January 2009

Cost Impact: The code change proposal will not increase the cost of construction.

FS124-12

Public Hearing: Committee: AS AM D
 Assembly: ASF AMF DF

T721.1(3) #2-FS-FRANCIS

FS125 – 12

722.2.2.1

Proponent: Jason J. Krohn, P.E., representing the Precast/Prestressed Concrete Institute (jkrohn@pci.org)

Revise as follows:

722.2.2.1 Reinforced and prestressed floors and roofs. The minimum thicknesses of reinforced and prestressed concrete floor or roof slabs for *fire-resistance ratings* of 1 hour to 4 hours are shown in Table 722.2.2.1.

Exception: Minimum thickness shall not be required for floors and ramps within open and enclosed parking garages constructed in accordance with Sections 406.5 and 406.6, respectively.

Reason:

1. Section 712.1.9 permits floor openings for automobile ramps in open and enclosed parking garages without shaft enclosures.
2. Exception 5 of Section 715.1 does not require fire-resistant joint systems for floors and ramps within open and enclosed parking garages or structures.

Referenced standard ACI 216.1-07, *Standard Method for Determining Fire Resistance of Concrete and Masonry Construction Assemblies*, states that the purpose of the minimum thickness requirements (Section 722.2.2.1) is for "barrier fire resistance." It can be concluded from section 712.1.9 and 715.1 that there is no intent of creating a fire barrier between floors and ramps in open and enclosed parking garages. Therefore, there is no logic in requiring a minimum thickness for floors and ramps of open and enclosed parking garages due to heat transmission theory.

Even with this proposed exception, Section 722.2.3 requires the minimum thickness of concrete cover over reinforcement which is necessary to preserve the structural integrity of the floors and can be used to meet the structural end point criteria. Section 722.2.3 specifies the concrete cover protection for the purposes of maintaining fire endurance of the structural element.

Cost Impact: The code change proposal will not increase the cost of construction.

FS125-12

Public Hearing:	Committee:	AS	AM	D
	Assembly:	ASF	AMF	DF

722.2.2.1-FS-KROHN

FS126 – 12

722.5.1.2.1, Figure 722.5.1(2), Figure 722.5.1(3)

Proponent: Michael Gardner, representing Gypsum Association (mgardner@gypsum.org)

Revise as follows:

722.5.1.2.1 Attachment. The gypsum ~~wallboard~~ board or gypsum panel products shall be supported as illustrated in either Figure 722.5.1(2) for fire-resistance ratings of 4 hours or less, or Figure 722.5.1(3) for fire-resistance ratings of 3 hours or less.

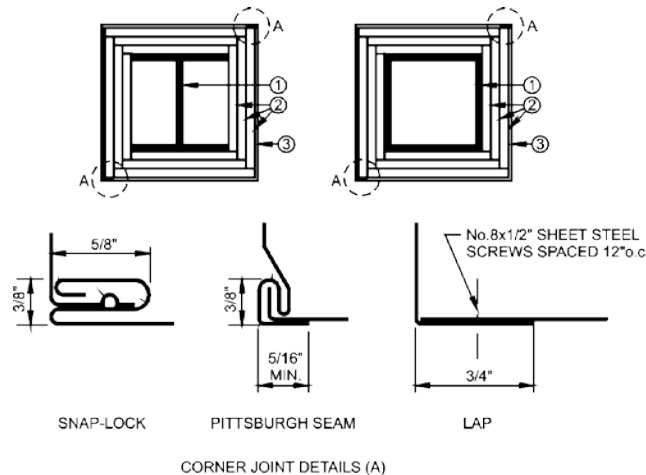

FIGURE 722.5.1(2)

GYPHUM WALLBOARD PROTECTED STRUCTURAL STEEL COLUMNS WITH SHEET STEEL COLUMN COVERS

For SI: 1 inch = 25.4 mm, 1 foot = 305 mm.

1. Structural steel column, either wide flange or tubular shapes.
2. Type X gypsum ~~wallboard~~ board or gypsum panel products in accordance with ASTM C 36, C 1177, C 1178, C 1278, C 1396 or C 1658. The total thickness of gypsum board or gypsum panel products calculated as h in 722.5.1.2, shall be applied vertically to an individual column using one of the following methods:
 1. As a single layer with no horizontal joints.
 2. As multiple layers with no horizontal joints permitted in any layer.
 3. As multiple layers with horizontal joints staggered not less than 12 inches vertically between layers and not less than 8 feet vertically in any single layer. For single-layer applications, the wallboard shall be applied vertically with no horizontal joints. For multiple-layer applications, horizontal joints are permitted at a minimum spacing of 8 feet, provided that the joints in successive layers are staggered at least 12 inches. The total required thickness of wallboard gypsum board or gypsum panel products shall be determined on the basis of the specified fire-resistance rating and the weight-to-heated-perimeter ratio (W/D) of the column. For fire-resistance ratings of 2 hours or less, one of the required layers of gypsum wallboard board or gypsum panel product may be applied to the exterior of the sheet steel column covers with 1-inch long Type S screws spaced 1 inch from the wallboard edge and 8 inches on center. For such installations, 0.0149-inch minimum thickness galvanized steel corner beads with 1 1/2-inch legs shall be attached to the wallboard with Type S screws spaced 12 inches on center.
3. For fire-resistance ratings of 3 hours or less, the column covers shall be fabricated from 0.0239-inch minimum thickness galvanized or stainless steel. For 4-hour fire-resistance ratings, the column covers shall be fabricated from 0.0239-inch minimum thickness stainless steel. The column covers shall be erected with the Snap Lock or Pittsburgh joint details. For fire-resistance ratings of 2 hours or less, column covers fabricated from 0.0269-inch minimum thickness galvanized or stainless steel shall be permitted to be erected with lap joints. The lap joints shall be permitted to be located anywhere around the perimeter of the column cover. The lap joints shall be secured with 1/2-inch-long No. 8 sheet metal screws spaced 12 inches on center. The column covers shall be provided with a minimum expansion clearance of 1/8 inch per linear foot between the ends of the cover and any restraining construction.

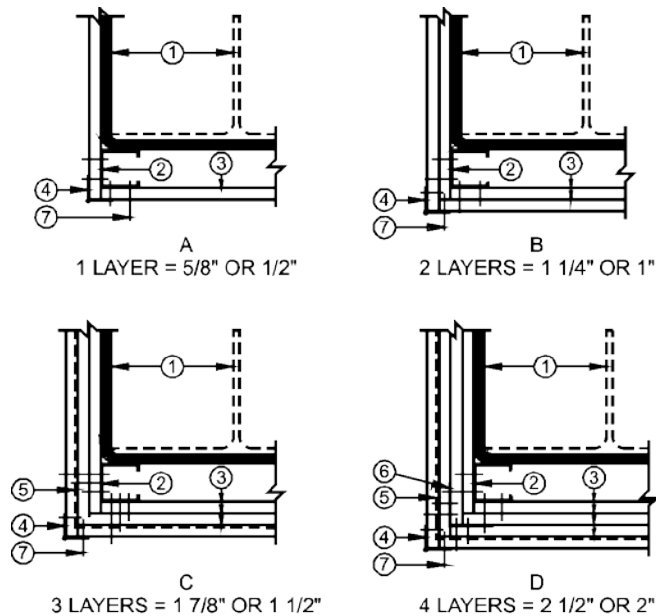

FIGURE 722.5.1(3)
GYPSON WALLBOARD PROTECTED STRUCTURAL STEEL COLUMNS WITH STEEL
STUD/SCREW ATTACHMENT SYSTEM

For SI: 1 inch = 25.4 mm, 1 foot = -305 mm.

1. Structural steel column, either wide flange or tubular shapes.
2. $1\frac{5}{8}$ -inch deep studs fabricated from 0.0179-inch minimum thickness galvanized steel with 15/16 or 17/16-inch legs. The length of the steel studs shall be 1/2 inch less than the height of the assembly.
3. Type X gypsum board or gypsum panel products wallboard-in accordance with ASTM C36-C177, C1178, C1278, C1396 pr C1658. The total thickness of gypsum board or gypsum panel products calculated as h in 722.5.1.2, shall be applied vertically to an individual column using one of the following methods:
 1. As a single layer with no horizontal joints.
 2. As multiple layers with no horizontal joints permitted in any layer.
 3. As multiple layers with horizontal joints staggered not less than 12 inches vertically between layers and not less than 8 feet vertically in any single layer For single-layer applications, the wallboard shall be applied vertically with no horizontal joints. For multiple-layer applications, horizontal joints are permitted at a minimum spacing of 8 feet, provided that the joints in successive layers are staggered at least 12 inches. The total required thickness of wallboard gypsum board or gypsum panel products shall be determined on the basis of the specified fire-resistance rating and the weight-to-heated-perimeter ratio (W/D) of the column.
4. Galvanized 0.0149-inch minimum thickness steel corner beads with 1 1/2-inch legs attached to the wallboard gypsum board or gypsum panel products with 1-inch-long Type S screws spaced 12 inches on center.
5. No. 18 SWG steel tie wires spaced 24 inches on center.
6. Sheet metal angles with 2-inch legs fabricated from 0.0221-inch minimum thickness galvanized steel.
7. Type S screws, 1 inch long, shall be used for attaching the first layer of wallboard gypsum board or gypsum panel product to the steel studs and the third layer to the sheet metal angles at 24 inches on center. Type S screws 1 3/4-inch long shall be used for attaching the second layer of wallboard gypsum board or gypsum panel product to the steel studs and the fourth layer to the sheet metal angles at 12 inches on center. Type S screws 2 1/4 inches long shall be used for attaching the third layer of wallboard gypsum board or gypsum panel product to the steel studs at 12 inches on center.

Reason: The existing language requirement that prohibits the installation of horizontal joints in a single-layer protection system is occasionally overlooked or ignored. In addition, the phrase requiring a “minimum spacing of 8 feet between joints” is being misinterpreted and applied to the horizontal distance between joints in adjacent columns and not the joints in a single column.

Proposal presents the language in a clearer format that is intended to specifically define the three possible application methods for the gypsum board or gypsum panel protection system.

To clarify that materials other than gypsum wallboard can be used to achieve the desired fire-resistance-rating, the proposal inserts language acknowledging that Type X gypsum panel products – gypsum products manufactured without a paper facing – and gypsum board materials other than gypsum wallboard may be used to achieve the desired fire-resistance rating.

Cost Impact: No change to the cost of construction.

FS126-12

Public Hearing:	Committee:	AS	AM	D
	Assembly:	ASF	AMF	DF

722.5.1.2.1-FS-GARDNER

FS127 – 12

722.6.1.2

Proponent: Larry Wainright, Qualtim, representing the Structural Building Components Association (lwainright@qualtim.com)

Revise as follows:

722.6.1.2 Dissimilar membranes. Where dissimilar membranes are used on a an interior wall assembly, the calculation shall be made from the least fire-resistant (weaker) side.

Reason: To avoid confusion between the requirements for interior and exterior walls. Except where required elsewhere in the code to have fire resistance calculated for exterior exposure, the requirements for exterior walls apply only exposure from the interior of the structure (722.6.2.3). This language is intended to provide clarity and is not intended to change any requirement of the code.

Cost Impact: This proposal will not increase the cost of construction.

FS127-12

Public Hearing:	Committee:	AS	AM	D
	Assembly:	ASF	AMF	DF

722.6.1.2-FS-WAINRIGHT

FS128 – 12

702.1, Table 722.6.2(3), 2603.5.7

Proponent: John Mulder, Intertek Testing Services NA, Inc., representing International Standards Organization Technical Committee 77, Products in Fibre-reinforced Cement and self

Revise as follows:

702.1 Definitions. The following terms are defined in Chapter 2:

FIBER-CEMENT SIDING

**TABLE 722.6.2(3)
MEMBRANE^a ON EXTERIOR FACE OF WOOD STUD WALLS**

SHEATHING	PAPER	EXTERIOR FINISH
$\frac{5}{8}$ – inch T & G lumber $\frac{5}{16}$ – inch exterior glue wood structural panel $\frac{1}{2}$ - inch gypsum wallboard $\frac{5}{8}$ – inch gypsum wallboard $\frac{1}{2}$ - inch fiberboard	Sheathing paper	Lumber siding Wood shingles and shakes <u>$\frac{1}{4}$-inch fiber-cement lap, panel or shingle siding</u> $\frac{1}{4}$ -inch wood structural panels- exterior type $\frac{1}{4}$ -inch hardboard Metal siding Stucco on metal lath Masonry veneer Vinyl siding
None		$\frac{3}{8}$ – inch exterior-grade wood structural panels

For SI: 1 pound/cubic foot = 16.0185 kg/m².

a. Any combination of sheathing, paper and exterior finish is permitted.

Revise as follows:

2603.5.7 Ignition. Exterior walls shall not exhibit sustained flaming where tested in accordance with NFPA 268. Where a material is intended to be installed in more than one thickness, tests of the minimum and maximum thickness intended for use shall be performed.

Exception: Assemblies protected on the outside with one of the following:

1. A thermal barrier complying with Section 2603.4.
2. A minimum 1 inch (25 mm) thickness of concrete or masonry.
3. Glass-fiber-reinforced concrete panels of a minimum thickness of $\frac{3}{8}$ inch (9.5 mm).
4. Metal-faced panels having minimum 0.019-inch-thick (0.48 mm) aluminum or 0.016-inch-thick (0.41 mm) corrosion-resistant steel outer facings.
5. A minimum $\frac{7}{8}$ inch (22.2 mm) thickness of stucco complying with Section 2510.
6. A minimum $\frac{1}{4}$ -inch (6.4 mm) thickness of fiber-cement lap, panel or shingle siding complying with Section 1405.16 and 1405.16.1 or 1405.16.2.

Reason:

1. A revision to Table 722.6.2(3) is proposed to include “fiber-cement lap, panel and shingle siding”. The term “fiber-cement products” is proposed to be included in the definitions here consistent with the definition published in the Terminology Standard ASTM C1154-06, *Standard Terminology for Non-Asbestos Fiber-Reinforced Cement Products* (see attached Standard) and also proposed for revision in Chapter 2 of the IBC code.
2. The application of $\frac{1}{4}$ -inch fiber-cement lap, panel or shingle siding complying with ASTM C1186, Type A (or ISO 8336 Category A) provides less potential for flame spread and smoke developed than the current wood-based and vinyl siding products currently recognized for use in this table. Fiber-cement siding having a flame spread of 0 and smoke developed index

of 5 or less as required in the referenced specifications (see attached ICC-ES ESR-1381[reference Section 3.0], ESR-1572[reference Section 3.0], ESR-1844[reference Section 3.1], ESR-2290[reference Section 3.1], and ESR-2894[reference Section 3.2] as supporting documents) provides a greater level of fire protection than the wood or vinyl siding currently permitted under Section 722.6.2.3 of the Code.

3. ¼-inch thick fiber-cement product complying with the provisions of Section 1405.16 (“complying with the requirements of ASTM C1186, Type A, minimum Grade II [or ISO 8336, Category A, Class 2]) has a flame spread of 0 and smoke developed index of 5 or less. The proposed fiber-cement siding is also classed as noncombustible in accordance with ASTM E 136 (see ICC-ES ESR-1381[reference Section 3.0], ESR-1572[reference Section 3.0], ESR-1844[reference Section 3.1], ESR-2290[reference Section 3.1], and ESR-2894[reference Section 3.2]) documenting these claims (<http://www.icc-es.org/>).

Cost Impact: The code change proposal will not increase the cost of construction because the change only adds a new term to the definitions section of Chapter 7, and because the proposed addition of fiber-cement siding products to the table [(722.6.2(3))] and to the exceptions (2603.5.7) only provides for the choice and use of a type of siding product having greater fire resistance.

FS128-12

Public Hearing:	Committee:	AS	AM	D
	Assembly:	ASF	AMF	DF

702 FIBER CEMENT PRODUCTS-FS-FULDER AND T722.6.2(3)-FS-MULDER-2603.5.7-FES-MULDER

FS129 – 12

Table 722.6.2(4)

Proponent: John Mulder, Intertek Testing Services NA, Inc., representing International Standards Organization Technical Committee 77, *Products in Fibre-reinforced Cement* and Self

Revise as follows:

**TABLE 722.6.2(4)
FLOORING OR ROOFING OVER WOOD FRAMING^a**

ASSEMBLY	STRUCTURAL MEMBERS	SUBFLOOR OR ROOF DECK	FINISHED FLOORING OR ROOFING
Floor	Wood	$\frac{15}{32}$ – inch wood structural panels or $\frac{11}{16}$ – inch T & G softwood	Hardwood or softwood flooring on building paper, resilient flooring, parquet floor, felted-synthetic fiber floor covering, carpeting or ceramic tile on $\frac{1}{4}$ -inch-thick fiber-cement underlayment or ceramic tile on $\frac{3}{8}$ -inch-thick panel type underlay Ceramic tile on $1\frac{1}{4}$ -inch mortar bed
Roof	Wood		Finished roofing material with or without insulation

For SI: 1 pound/cubic foot = 16.0185 kg/m².

a. Any combination of sheathing, paper and exterior finish is permitted.

Reason: Add comma between building paper and resilient flooring and between parquet floor and felted-synthetic fiber floor covering to clean up the language. $\frac{1}{4}$ -inch fiber-cement underlayment (having a flame spread of 0 and smoke developed index of 5 or less as required in the referenced product specifications (ASTM C1288, Grade II) or [ISO 8336, Type C, Class 2]) provides a greater level of fire protection than the wood panel-type underlay currently permitted under Section 722.6.2.4 of the Code. The proposed fiber-cement underlayment is also classed as noncombustible in accordance with ASTM E 136 (see ICC-ES ESR-1381[reference Section 3.0], ESR-2280[reference Section 3.1], and ESR-2292[reference Section 3.0]) as supporting documentation (<http://www.icc-es.org/>).

Cost Impact: The code change proposal will not increase the cost of construction because the proposed addition of fiber-cement underlayment products to the table only provides for the choice and use of a type of underlayment product having greater fire resistance than the product currently recognized.

FS129-12

Public Hearing: Committee: AS AM D
 Assembly: ASF AMF DF

722.6.2(4)-FS-MULDER

FS130 – 12

722.6.3

Proponent: Sam Francis, American Wood Council (sfrancis@awc.org)

Delete without substitution:

722.6.3 Design of fire-resistant exposed wood members. The fire resistance rating, in minutes, of timber beams and columns with a minimum nominal dimension of 6 inches (152 mm) is equal to:

Beams: $2.54Zb [4 - 2(b/d)]$ for beams which may be exposed to fire on four sides. (Equation 7-18)

$2.54Zb [4 - (b/d)]$ for beams which may be exposed to fire on three sides. (Equation 7-19)

Columns: $2.54Zd [3 - (d/b)]$ for columns which may be exposed to fire on four sides (Equation 7-20)

$2.54Zd [3 - (d/2b)]$ for columns which may be exposed to fire on three sides. (Equation 7-21)

where:

- b = The breadth (width) of a beam or larger side of a column before exposure to fire (inches).
- d = The depth of a beam or smaller side of a column before exposure to fire (inches).
- Z = Load factor, based on Figure 722.6.3(1).

722.6.3.1 Equation 7-21. Equation 7-21 applies only where the unexposed face represents the smaller side of the column. If a column is recessed into a wall, its full dimension shall be used for the purpose of these calculations.

722.6.3.2 Allowable loads. Allowable loads on beams and columns are determined using design values given in AF&PA NDS.

722.6.3.3 Fastener protection. Where minimum 1-hour *fire resistance* is required, connectors and fasteners shall be protected from fire exposure by 1 1/2 inches (38 mm) of wood, or other *approved* covering or coating for a 1-hour rating. Typical details for commonly used fasteners and connectors are shown in AITC Technical Note 7.

722.6.3.4 Minimum size. Wood members are limited to dimensions of 6 inches (152 mm) nominal or greater. Glued-laminated timber beams utilize standard laminating combinations except that a core lamination is removed. The tension zone is moved inward and the equivalent of an extra nominal 2-inch-thick (51 mm) outer tension lamination is added.

FIGURE 722.6.3(1) LOAD FIGURE

- K_e = The effective length factor as noted in Figure 722.6.3(2).
- l = The unsupported length of columns (inches).

FIGURE 722.6.3(2) EFFECTIVE LENGTH FACTORS

Reason: A more robust design methodology for designing these members is contained in Chapter 16 of *the National Design Specification for Wood construction (NDS)*. This ANSI consensus standard is referenced in 722.1.

Cost Impact: The code change proposal will not increase the cost of construction.

FS130-12

Public Hearing:	Committee:	AS	AM	D
	Assembly:	ASF	AMF	DF

722.6.3-FS-FRANCIS

FS131 – 12

803.2

Proponent: Marcelo M Hirschler, GBH International (gbhint@aol.com)

Revise as follows:

803.2 Thickness exemption. Materials having a thickness less than 0.036 inch (0.9 mm) applied directly to the surface of walls or ceilings shall not be required to be tested if the surface to which they are applied complies with the requirements of section 703.5.1 or of section 703.5.2, as appropriate.

Reason: This section is intended to avoid the need to test very thin materials (such as the paper covering on gypsum board or other thin layers) applied directly to noncombustible surfaces. That is very reasonable, since very thin layers will not add a significant level of fire safety to a surface when there is no significant flame spread from the substrate itself.

Unfortunately, however, this section has been used as the excuse for applying facings or veneers to wood surfaces and having them exempted. In that case the interpretation of this section results in the use of materials where there is no fire testing of the facing or veneer and no fire testing of the composite system (i.e. the facing or veneer and the wood backing).

If the surface is an untreated wood surface (with a typical flame spread index of 100-200), adding a combustible facing or veneer (and the corresponding adhesive) is likely to increase the flame spread index to exceed 200 and thus to go from a Class C to an unclassified material. If the surface is a fire-retardant-treated wood (FRTW) surface (with always has a flame spread index of less than 25), the effect of adding a combustible facing or veneer (which is not composed of FRTW) together with the corresponding adhesive, is virtually guaranteed to increase the flame spread index so as to exceed 25 and thus to go from a material classified as a Class A material to one classified as a Class B or worse. Note that specific test results cannot be presented because the available information is based on proprietary tests.

Please note that this code change proposal would not affect gypsum board as the language of section 703.5 of the IBC was specifically designed so that gypsum board is classified as a noncombustible material, in accordance with 703.5.2, as shown below:

703.5 Noncombustibility tests. The tests indicated in Sections 703.5.1 and 703.5.2 shall serve as criteria for acceptance of building materials as set forth in Sections 602.2, 602.3 and 602.4 in Type I, II, III and IV construction. The term "noncombustible" does not apply to the flame spread characteristics of interior finish or trim materials. A material shall not be classified as a noncombustible building construction material if it is subject to an increase in combustibility or flame spread beyond the limitations herein established through the effects of age, moisture or other atmospheric conditions.

703.5.1 Elementary materials. Materials required to be noncombustible shall be tested in accordance with ASTM E 136.

703.5.2 Composite materials. Materials having a structural base of noncombustible material as determined in accordance with Section 703.5.1 with a surfacing not more than 0.125 inch (3.18 mm) thick that has a flame spread index not greater than 50 when tested in accordance with ASTM E 84 or UL 723 shall be acceptable as noncombustible materials.

Cost Impact: None

FS131-12

Public Hearing:	Committee:	AS	AM	D
	Assembly:	ASF	AMF	DF

803.2-FS-HIRSCHLER

FS132 – 12

803.3

Proponent: Sam Francis, American Wood Council (sfrancis@awc.org)

Revise as follows:

803.3 Heavy timber exemption. Exposed portions of ~~structural members~~ building elements complying with the requirements for buildings of Type IV construction in Section 602.4 shall not be subject to *interior finish* requirements.

Reason: "Structural members" is not a well defined term. Building Elements is a term used in Table 601 to refer to various structural members. The various members in Table 601 are part of the structural frame concept upon which the table is based. The intent here is to use an expression which is familiar to the user and understandable to the enforcer and practitioner.

Cost Impact: The code change proposal will not increase the cost of construction.

FS132-12

Public Hearing:	Committee:	AS	AM	D
	Assembly:	ASF	AMF	DF

803.3-FS-FRANCIS

FS133 – 12

202, 803.14 (New), 803.14.1 (New), 803.14.2 (New)

Proponent: Jesse J. Beitel, Hughes Associates, Inc., representing Scranton Products
(jbeitel@haifire.com)

Revise definition as follows:

INTERIOR WALL AND CEILING FINISH. The exposed *interior surfaces* of buildings, including but not limited to: fixed or movable walls and partitions; ~~toilet room privacy partitions~~; columns; ceilings; and interior wainscoting, paneling or other finish applied structurally or for decoration, acoustical correction, surface insulation, structural fire resistance or similar purposes, but not including *trim*.

Add new text as follows:

803.14 Toilet Room Privacy Partitions. Toilet room privacy partitions shall comply with the requirements of 803.14.1 and 803.14.2.

803.14.1 Flame-spread. Toilet room privacy partitions shall comply with 803.1.1.

803.14.2 Full-scale Testing. If the toilet room privacy partitions exhibit melting or dripping during the ASTM E 84 or UL 723 test, the toilet room privacy partition shall also comply with the requirements of 803.1.2.

Reason: Currently, toilet room partitions must be tested to ASTM E84 or UL 723 (Section 803.1.1). However, if the toilet room privacy partition is constructed of high-density polyethylene or polypropylene then Section 803.12 requires that the material must be tested per NFPA 286 (Section 803.1.2).

Section 803.12 was developed to address the specific issue of melting and dripping materials that might provide a Flame-spread Index that is not indicative of their actual performance. Based on previous full-scale fire testing which identified the burning of melting and dripping material as a potential hazard, the NFPA 286 fire testing was required. One example used to justify this Code section was toilet room privacy partitions.

However, if a high-density polyethylene or polypropylene can be formulated for this application and which show that melting and dripping does not occur, then these products should be allowed to only be tested per ASTM E 84 or UL 723.

Additionally, if melting and dripping is an issue for some polymeric materials used in this application, then the same requirements should be applied to all other polymeric materials used in this application. This Code proposal addresses these issues in the proposed new section.

Cost Impact: The Code change proposal will increase the cost of construction because for those materials used in this application that melt and drip and are not subject to section 803.12, additional testing will be required.

FS133-12

Public Hearing:	Committee:	AS	AM	D
	Assembly:	ASF	AMF	DF

803.14 (NEW)-FS-BEITEL

FS134_____ – 12
901.1

Proponent: Tom Allen, City of Mount Dora, FL, representing self

Revise as follows:

901.1 Scope. The provisions of this chapter shall specify where fire protections systems are required and shall apply to the design, installation and operation of fire protection systems and carbon monoxide alarms and detection systems.

Reason: Adds carbon monoxide detection to scope of chapter 9, goes with new section 916.

Cost Impact: There is not a cost impact.

Analysis: The "new section 916" mentioned in the reason statement is a Group B code change to be heard by the IFC code development committee.

FS134-12

Public Hearing:	Committee:	AS	AM	D
	Assembly:	ASF	AMF	DF

901.1-FS-ALLEN

FS135-12

909.10.3 (New) (IFC 909.10.3 (New)), Chapter 35

Proponent: Tony Crimi, A.C. Consulting Solutions Inc, representing International Firestop Council (tcrimi@sympatico.ca)

Revise as follows:

909.10.3 Fire-r esistance Rated Duct Enclosures. Where ducts form part of a required *smoke control* system and penetrate a fire-resistance rated wall assemblies or *horizontal assembly*, they shall comply with the requirements of ASTM E2816.

Exception: Where the installation of a *smoke or fire damper* will not interfere with the operation of a required smoke control system in accordance with Section 909. penetrations by ducts and air transfer openings are permitted to comply with Section 717.

(Renumber subsequent sections)

Add new standard to Chapter 35 as follows:

ASTM

E2816-11. Standard Test Methods for Fire Resistive Metallic HVAC Duct Systems.

Reason: This proposal would require HVAC ducts installed as part of a required smoke control system to be protected by a tested and listed assembly conforming to the new ASTM E2816-11, Standard Test Methods for Fire Resistive Metallic HVAC Duct Systems evaluated for the specific purpose. In addition, an exception to comply with section 717 is incorporated. This principle of protecting HVAC ducts used as part of a smoke control system from the effects of fire exposure is already contained in section 909.4 as part of a rational analysis supporting the design of smoke control systems to be employed. Section 909.4.4 requires that the design shall consider the effects of the heating, ventilating and air-conditioning (HVAC) systems on both smoke and fire transport. The analysis must include all permutations of systems status, and the design shall consider the effects of the fire on the HVAC systems.

This test is now also referenced as part of ICC-ES AC179, Acceptance Criteria for Metallic HVAC Duct Enclosure Assemblies. The purpose of these acceptance criteria is to establish requirements for fire protection enclosure systems applied to metallic HVAC ducts, which provides an alternate to required fire-resistance-rated shafts or an alternate to required fire dampers in specific locations. This criteria provides an alternate to shaft enclosures for vertical ducts, and an alternate to fire dampers in horizontal ducts (penetrating fire barriers, fire partitions, and or smoke barriers) and vertical ducts connecting multiple stories.

The new ASTM Standard evaluates the HVAC duct systems for surface burning characteristics, non-combustibility, fire resistance, durability, and fire engulfment with horizontal and vertical through-penetration firestops. The Standard can evaluate the fire performance of HVAC ducts for both supply (pressurization) and return air, in the vertical and horizontal orientation, with or without openings. These test methods evaluate the ability of a HVAC duct system to resist the spread of fire from one compartment to another compartment separated by fire resistance rated construction when the HVAC duct system is exposed to fire from the outside of the horizontal or vertical HVAC duct system, or from the outside with hot gases entering the inside of the HVAC duct system from unprotected openings, when subjected to the standard time-temperature curve of ASTM E119.

Cost Impact: This change will not affect the cost of construction.

Analysis: FS58, Part II and FS 135 contain similar requirements for ducts that form smoke control systems. The committee needs to make its intent clear with respect to these provisions. A review of the standard proposed for inclusion in the code, ASTM E2816-11 with regard to the ICC criteria for referenced standards (Section 3.6 of CP#28) will be posted on the ICC website on or before April 2, 2012.

FS135-12

Public Hearing:	Committee:	AS	AM	D
	Assembly:	ASF	AMF	DF

909.10.3 (NEW)-FS-CRIMI

FS136 – 12

909.20.5.1 (New), Chapter 35

Proponent: Tony Crimi, A.C. Consulting Solutions Inc, representing International Firestop Council (tcrimi@sympatico.ca)

Add new text as follows:

909.20.5.1 Stair Pressurization Ducts. Where interior exit stairways are pressurized, HVAC ducts used to supply uncontaminated air shall be protected with a shaft enclosures in accordance with Section 713, or tested in accordance with ASTM E2816.

Add new standard to Chapter 35 as follows:

ASTM

E2816-11, Standard Test Methods for Fire Resistive Metallic HVAC Duct Systems.

Reason: This proposal would require HVAC ducts installed for the purposes of stairwell pressurization to be enclosed within a shaft or protected by a tested and listed assembly conforming to the new *ASTM E2816-11, Standard Test Methods for Fire Resistive Metallic HVAC Duct Systems* evaluated for the specific purpose. The new ASTM Standard evaluates the HVAC duct systems for surface burning characteristics, non-combustibility, fire resistance, durability, and fire engulfment with horizontal and vertical through-penetration firestops. The Standard can evaluate the fire performance of HVAC ducts for both supply (pressurization) and return air, in the vertical and horizontal orientation, with or without openings. These test methods evaluate the ability of a HVAC duct system to resist the spread of fire from one compartment to another compartment separated by fire resistance rated construction when the HVAC duct system is exposed to fire from the outside of the horizontal or vertical HVAC duct system, or from the outside with hot gases entering the inside of the HVAC duct system from unprotected openings, when subjected to the standard time-temperature curve of ASTM E119. This test is now also referenced as part of ICC-ES AC179, Acceptance Criteria for Metallic HVAC Duct Enclosure Assemblies. The purpose of these acceptance criteria is to establish requirements for fire protection enclosure systems applied to metallic HVAC ducts, which provides an alternate to required fire-resistance-rated shafts or an alternate to required fire dampers in specific locations. This criteria provides an alternate to shaft enclosures for vertical ducts, and an alternate to fire dampers in horizontal ducts (penetrating fire barriers, fire partitions, and or smoke barriers) and vertical ducts connecting multiple stories.

The purpose of a closed pressurization system is to provide fresh air directly to stairwells or egress areas. This design air pressures need to be sufficient to maintain closed doors while preventing smoke from entering the egress path. . Smoke control systems have been required in nearly two thirds of the United States for over a decade. High-rise buildings constructed to the requirements of International Building Code, but without any specific measures to control smoke migration, are all the more vulnerable to property damage and occupants' loss of life.

Pressurization results in airflows of high velocity in the gaps around closed doors and construction cracks, thereby preventing smoke from flowing back into the pressurized space through these openings. Pressurized stairwells are provided with the goal of maintaining a tenable environment within the escape routes in the event of a building fire. While the option to use stairwell pressurization exists, the IBC does not require stairwell pressurization in high-rise buildings, and only requires smoke control in underground buildings, atriums, and covered mall buildings. Section 403.5.4 of the 2012 IBC requires smokeproof exit enclosures for high-rise buildings in every required stairway serving floors more than 75 feet (22.86 m) above the ground. Section 909.20.5 merely permits sprinklered buildings to use stairwell pressurization as an alternate to the smokeproof enclosures. When employed, ducts used for Stair pressurization to provide uncontaminated air within required interior exit stairwells or areas of egress need to be protected from the effect of fire, or constructed as fire resistant systems.

This principle of protecting HVAC ducts used as part of a smoke control system from the effects of fire exposure is already contained in section 909.4 as part of a rational analysis supporting the design of smoke control systems to be employed. Section 909.4.4 requires that the design shall consider the effects of the heating, ventilating and air-conditioning (HVAC) systems on both smoke and fire transport. The analysis must include all permutations of systems status, and the design shall consider the effects of the fire on the HVAC systems.

Particularly in the case of tall buildings, the predominant factors that cause smoke movement are stack effects, the affect of external wind forces, and forced air movement within the building. Smoke removal and venting practices are complicated by stack effects, which will tend to favour natural air movement vertically through the building as a results of differences in temperature and densities between the inside and outside air. ¹

Options such as the use of natural ventilation are only available where openings in exterior stairwells can be accommodated. Even then, a number of problems have been identified with this approach. Firstly, the required volume of fresh air is high. Secondly, natural supply and exhaust through vents may be subject to adverse exterior wind conditions, and even when functioning satisfactorily, would generally require vents located on different exterior walls. Thirdly, the performance of natural vents is influenced by building stack effects, which may be particularly significant on the upper or lowermost stories for tall buildings. This effect can range from either strong inflow or strong outflow from all natural vents on a given storey. ²

Bibliography:

1. Klotz, J.H. and Milke, J.A. Fire Protection Handbook, NFPA 19th Edition, Volume II, Smoke Movement in Buildings, Chapter 6, Section 12-113 –12-126
2. Building Research Establishment, UK, Smoke Ventillation of Common Access Areas of Flats & Maisonettes (BD2410), Final Factual Report, Appendix A (Review), BRE Ltd, 2005

Cost Impact: This change will not affect the cost of construction.

Analysis: FS58, Part III and FS 136 contain similar requirements for stair pressurization ducts. The committee needs to make its intent clear with respect to these provisions. A review of the standard proposed for inclusion in the code, ASTM E2816-11 with regard to the ICC criteria for referenced standards (Section 3.6 of CP#28) will be posted on the ICC website on or before April 2, 2012.

FS136-12

Public Hearing:	Committee:	AS	AM	D
	Assembly:	ASF	AMF	DF

909.20.5.1-FS-CRIMI

FS137 – 12

909.20.6.1, 909.20.6.2 (New), Chapter 35

Proponent: Tony Crimi, A.C. Consulting Solutions Inc, representing International Firestop Council (tcrimi@sympatico.ca)

Revise as follows:

909.20.6.1 Ventilation systems. Smokeproof enclosure ventilation systems shall be independent of other building ventilation systems. The equipment, control wiring, power wiring and ductwork shall comply with one of the following:

1. Equipment, control wiring, power wiring and ductwork shall be located exterior to the building and directly connected to the smokeproof enclosure or connected to the smokeproof enclosure by ductwork enclosed by not less than 2-hour *fire barriers* constructed in accordance with Section 707 or *horizontal assemblies* constructed in accordance with Section 711, or both, or with ductwork conforming to 909.20.6.2.
2. Equipment, control wiring, power wiring and ductwork shall be located within the smokeproof enclosure with intake or exhaust directly from and to the outside or through ductwork enclosed by not less than 2-hour *fire barriers* constructed in accordance with Section 707 or *horizontal assemblies* constructed in accordance with Section 711, or both, or with ductwork conforming to 909.20.6.2.
3. Equipment, control wiring, power wiring and ductwork shall be located within the building if separated from the remainder of the building, including other mechanical equipment, by not less than 2-hour *fire barriers* constructed in accordance with Section 707 or *horizontal assemblies* constructed in accordance with Section 711, or both, or with ductwork conforming to 909.20.6.2.

909.20.6.2 Smokeproof enclosure ductwork. Ductwork tested and listed to have not less than 2-hour fire-resistance in accordance with ASTM E2816 shall be permitted to enclose equipment, control wiring, power wiring and ductwork required to comply with 9.20.6.1.

Add new standard to Chapter 35 as follows:

ASTM

E2816-11, Standard Test Methods for Fire Resistive Metallic HVAC Duct Systems.

Reason: This proposal would allow an additional tested method of protection for enclosures used to protect equipment, control wiring, power wiring and ductwork required by 9.20.6.1. The enclosures or ductwork would be permitted to be used if it were protected by a tested and listed assembly conforming to the new *ASTM E2816-11, Standard Test Methods for Fire Resistive Metallic HVAC Duct Systems* evaluated for the specific purpose. This Standard has criteria for testing rigid or flexible fire protection enclosure systems (including stability, integrity, and insulation) that are installed on or as part of metallic HVAC ducts, yielding an alternate to required fire-resistance-rated shafts which are required to be protected from both internal and external fire exposure. This criteria provides an alternate to shaft enclosures for vertical ducts, and an alternate to fire dampers in horizontal ducts.

The new ASTM Standard evaluates the HVAC duct systems for surface burning characteristics, non-combustibility, fire resistance, durability, and fire engulfment with horizontal and vertical through-penetration firestops. The Standard can evaluate the fire performance of HVAC ducts for both supply (pressurization) and return air, in the vertical and horizontal orientation, with or without openings. These test methods evaluate the ability of a HVAC duct system to resist the spread of fire from one compartment to another compartment separated by fire resistance rated construction when the HVAC duct system is exposed to fire from the outside of the horizontal or vertical HVAC duct system, or from the outside with hot gases entering the inside of the HVAC duct system from unprotected openings, when subjected to the standard time-temperature curve of ASTM E119. This test is now also referenced as part of ICC-ES AC179, Acceptance Criteria for Metallic HVAC Duct Enclosure Assemblies. The purpose of these acceptance criteria is to establish requirements for fire protection enclosure systems applied to metallic HVAC ducts, which provides an alternate to required fire-resistance-rated shafts or an alternate to required fire dampers in specific locations. This criteria provides an alternate to shaft enclosures for vertical ducts, and an alternate to fire dampers in horizontal ducts (penetrating fire barriers, fire partitions, and or smoke barriers) and vertical ducts connecting multiple stories.

This principle of protecting HVAC ducts used as part of a smoke control system from the effects of fire exposure is already contained in section 909.4 as part of a rational analysis supporting the design of smoke control systems to be employed. Section 909.4.4 requires that the design shall consider the effects of the heating, ventilating and air-conditioning (HVAC) systems on both smoke and fire transport. The analysis must include all permutations of systems status, and the design shall consider the effects of the fire on the HVAC systems.

Cost Impact: This change will reduce the cost of construction.

Analysis: FS58, Part IV, FS 137 and FS139 contain similar requirements for smokeproof enclosure ventilation systems. The committee needs to make its intent clear with respect to these provisions. A review of the standard proposed for inclusion in the code, ASTM E2816-11 with regard to the ICC criteria for referenced standards (Section 3.6 of CP#28) will be posted on the ICC website on or before April 2, 2012.

FS137-12

Public Hearing:	Committee:	AS	AM	D
	Assembly:	ASF	AMF	DF

909.20.6.1-FS-CRIMI

FS138 – 12

202 (New), 909.20.6.1, 3007.9.1, 3008.9

Proponent: Vickie Lovell, InterCode Incorporated representing 3M Company (vickie@intercodeinc.com)

THIS CODE CHANGE WILL BE HEARD BY THE IBC-GENERAL COMMITTEE. SEE THE TENTATIVE HEARING ORDER FOR THIS COMMITTEE.

Add new definition as follows:

ELECTRICAL CIRCUIT PROTECTIVE SYSTEM. A specific construction of devices, materials, or coatings installed as a fire resistive barrier system applied to electrical system components, such as cable trays, conduits and other raceways, open run cables and conductors, cables, and conductors.

Revise as follows:

909.20.6 Ventilating equipment. The activation of ventilating equipment required by the alternatives in Sections 909.20.4 and 909.20.5 shall be by smoke detectors installed at each floor level at an *approved* location at the entrance to the smokeproof enclosure. When the closing device for the *stair* shaft and vestibule doors is activated by smoke detection or power failure, the mechanical equipment shall activate and operate at the required performance levels. Smoke detectors shall be installed in accordance with Section 907.3.

909.20.6.1 Ventilation systems. Smokeproof enclosure ventilation systems shall be independent of other building ventilation systems. The equipment, control wiring, power wiring and ductwork shall comply with one of the following:

1. Equipment, control wiring, power wiring and ductwork shall be located exterior to the building and directly connected to the smokeproof enclosure or connected to the smokeproof enclosure by ductwork enclosed by not less than 2-hour *fire barriers* constructed in accordance with Section 707 or *horizontal assemblies* constructed in accordance with Section 711, or both.
2. Equipment, control wiring, power wiring and ductwork shall be located within the smokeproof enclosure with intake or exhaust directly from and to the outside or through ductwork enclosed by not less than 2-hour *fire barriers* constructed in accordance with Section 707 or *horizontal assemblies* constructed in accordance with Section 711, or both.
3. Equipment, control wiring, power wiring and ductwork shall be located within the building if separated from the remainder of the building, including other mechanical equipment, by not less than 2-hour *fire barriers* constructed in accordance with Section 707 or *horizontal assemblies* constructed in accordance with Section 711, or both.

Exceptions:

1. Control wiring and power wiring utilizing a 2-hour rated cable, ~~or cable system~~
2. Where encased with not less than 2 inches (51 mm) of concrete.
3. Control wiring and power wiring protected by a listed electrical circuit protective system with a *fire-resistance rating* of not less than 2 hours.

Revise as follows:

3007.9 Electrical power. The following features serving each fire service access elevator shall be supplied by both normal power and Type 60/Class 2/Level 1 standby power:

1. Elevator equipment.
2. Elevator hoistway lighting.
3. Elevator machine room *ventilation* and cooling equipment.
4. Elevator controller cooling equipment.

3007.9.1 Protection of wiring or cables. Wires or cables that are located outside of the elevator hoistway and machine room and that provide normal or standby power, control signals, communication with the car, lighting, heating, air conditioning, *ventilation* and fire-detecting systems to fire service access elevators shall be protected by construction having a *fire-resistance rating* of not less than 2 hours, ~~or shall be a circuit integrity cable having a *fire-resistance rating* of not less than 2 hours,~~ or shall be protected by a listed electrical circuit protective system having a *fire-resistance rating* of not less than 2 hours.

Exception: Wiring and cables to control signals are not required to be protected provided that wiring and cables do not serve Phase II emergency in-car operations.

3008.9 Electrical power. The following features serving each occupant evacuation elevator shall be supplied by both normal power and Type 60/Class 2/Level 1 standby power:

1. Elevator equipment.
2. Elevator machine room *ventilation* and cooling equipment.
3. Elevator controller cooling equipment.

3008.9.1 Protection of wiring or cables. Wires or cables that are located outside of the elevator hoistway and machine room and that provide normal or standby power, control signals, communication with the car, lighting, heating, air conditioning, *ventilation* and fire-detecting systems to fire service access elevators shall be protected by construction having a *fire-resistance rating* of not less than 2 hours, or shall be circuit integrity cable having a *fire-resistance rating* of not less than 2 hours, or shall be protected by a listed electrical circuit protective system having a *fire-resistance rating* of not less than 2 hours.

Exception: Wiring and cables to control signals are not required to be protected provided that wiring and cables do not serve Phase II emergency in-car operations.

Reason: This proposal is intended to add the option of using fire-resistive cables, which are tested to UL 2196 *Tests for Fire Resistive Cables*, and to include the option of using conventional cables with a protective material applied to them. These materials are called electrical circuit protective systems.

Electrical circuit protective systems are already recognized by NFPA 70 the *National Electrical Code* for protection of fire pump control wiring, emergency system circuit wiring, and critical operations power system circuit wiring. The recognized standards to test fire-resistive electrical circuit protective systems are as follows:

- ASTM E1725 *Standard Test Methods for Fire Tests of Fire-Resistive Barrier systems for Electrical System Components.*
- UL 1724 *Fire Tests for Electrical Circuit Protective Systems*

The UL category for this designation of this type of protective system is FHIT.

This definition is a compilation of excerpts from the terminology section ASTM E1725 the *Standard Test Methods for Fire Tests of Fire-Resistive Barrier systems for Electrical System Components.*

Cost Impact: The code change proposal will not increase the cost of construction.

FS138-12

Public Hearing:	Committee:	AS	AM	D
	Assembly:	ASF	AMF	DF

909.20.6.1-FS-LOVELL

FS139 – 12

909.20.6.1, Chapter 35

Proponent: Mark Lund, representing 3M Company, Fire Protection Products (mwlund@mmm.com)

Revise as follows:

909.20.6.1 Ventilation systems. Smokeproof enclosure ventilation systems shall be independent of other building ventilation systems. The equipment, control wiring, power wiring and ductwork shall comply with one of the following:

1. Equipment, control wiring, power wiring and ductwork shall be located exterior to the building and directly connected to the smokeproof enclosure or connected to the smokeproof enclosure by ductwork enclosed by not less than 2-hour fire barriers constructed in accordance with Section 707 or horizontal assemblies constructed in accordance with Section 711, or both.
2. Equipment, control wiring, power wiring and ductwork shall be located within the smokeproof enclosure with intake or exhaust directly from and to the outside or through ductwork enclosed by not less than 2-hour fire barriers constructed in accordance with Section 707 or horizontal assemblies constructed in accordance with Section 711, or both.
3. Equipment, control wiring, power wiring and ductwork shall be located within the building if separated from the remainder of the building, including other mechanical equipment, by not less than 2-hour fire barriers constructed in accordance with Section 707 or horizontal assemblies constructed in accordance with Section 711, or both.

Exceptions:

1. Control wiring and power wiring utilizing a 2-hour rated cable or cable system.
2. Where encased with not less than 2 inches (51 mm) of concrete.
3. Ductwork tested and listed for not less than 2-hour fire-resistance in accordance with ASTM E2816

Add new standard to Chapter 35 as follows:

ASTM

E2816-11, Standard Test Methods for Fire Resistive Metallic HVAC Duct Systems.

Reason: This proposal would allow an additional tested method of protection for enclosures used to protect equipment, control wiring, power wiring and ductwork required by 909.20.6.1. The enclosures or ductwork would be permitted to be used if it were protected by a tested and listed assembly conforming to the new *ASTM E2816-11, Standard Test Methods for Fire Resistive Metallic HVAC Duct Systems* evaluated for the specific purpose. This Standard has criteria for testing rigid or flexible fire protection enclosure systems (including stability, integrity, and insulation) that are installed on or as part of metallic HVAC ducts, yielding an alternate to required fire-resistance-rated shafts which are required to be protected from both internal and external fire exposure. This criteria provides an alternate to shaft enclosures for vertical ducts, and an alternate to fire dampers in horizontal ducts.

The new ASTM Standard evaluates the HVAC duct systems for surface burning characteristics, non-combustibility, fire resistance, durability, and fire engulfment with horizontal and vertical through-penetration firestops. The Standard can evaluate the fire performance of HVAC ducts for both supply (pressurization) and return air, in the vertical and horizontal orientation, with or without openings. These test methods evaluate the ability of a HVAC duct system to resist the spread of fire from one compartment to another compartment separated by fire resistance rated construction when the HVAC duct system is exposed to fire from the outside of the horizontal or vertical HVAC duct system, or from the outside with hot gases entering the inside of the HVAC duct system from unprotected openings, when subjected to the standard time-temperature curve of ASTM E119.

This principle of protecting HVAC ducts used as part of a smoke control system from the effects of fire exposure is already contained in section 909.4 as part of a rational analysis supporting the design of smoke control systems to be employed. Section 909.4.4 requires that the design shall consider the effects of the heating, ventilating and air-conditioning (HVAC) systems on both smoke and fire transport. The analysis must include all permutations of systems status, and the design shall consider the effects of the fire on the HVAC systems.

Cost Impact: This change will reduce the cost of construction.

Analysis: FS58, Part IV, FS 137 and FS139 contain similar requirements for smokeproof enclosure ventilation systems. The committee needs to make its intent clear with respect to these provisions. A review of the standard proposed for inclusion in the code, ASTM E2816-11 with regard to the ICC criteria for referenced standards (Section 3.6 of CP#28) will be posted on the ICC website on or before April 2, 2012.

FS139-12

Public Hearing: Committee:
Assembly:

AS
ASF

AM
AMF

D
DF

909.20.6.1-FS-LUND

FS140 – 12

909.21.1

Proponent: Michael Perrino, CBO, Code Consultants, Inc., representing self

Revise as follows:

909.21.1 Pressurization requirements. Elevator hoistways shall be pressurized to maintain a minimum positive pressure of 0.10 inches of water (25 Pa) and a maximum positive pressure of 0.25 inches of water (67 Pa) with respect to adjacent occupied space on all floors. This pressure shall be measured at the midpoint of each hoistway door, with all elevator cars at the floor of recall and all hoistway doors on the floor of recall open and all other hoistway doors closed. The opening and closing of hoistway doors at each level must be demonstrated during this test. The supply air intake shall be from an outside, uncontaminated source located a minimum distance of 20 feet (6096 mm) from any air exhaust system or outlet.

Exception: The minimum positive pressure of 0.10 inches of water (25 Pa) and a maximum positive pressure of 0.25 inches of water (67 Pa) with respect to occupied floors is not required at the floor of recall with the doors open.

Reason: The IBC requires the pressure difference, required for the pressurization alternative, to be measured at the midpoint of each hoistway door, with all elevator cars at the floor of recall and all hoistway doors on the floor of recall open and all other hoistway doors closed. There is not currently an exception for the measurement of the pressure at the floor of elevator recall.

Elevator hoistway pressurization is intended to minimize smoke movement into an elevator shaft when a lobby is not provided. Meeting the required pressure difference on the recall floor with the hoistway doors open is not necessary, because the recall floor is protected by smoke detectors that will not allow the hoistway doors to open if smoke is present.

The pressurization method is based on using pressure differences produced by fans to minimize the spread of smoke across a barrier. A barrier will not exist on the recall floor when the hoistway doors are open and smoke detectors used for elevator recall prevent the doors from opening when smoke is present.

The intent of hoistway pressurization is to create the pressure difference between the floor of origin (low pressure) and the elevator hoistway (high pressure) to minimize smoke movement into the shaft. However, both a primary and alternate recall floor are provided so that the floor of fire origin will not be the designated level of recall. Therefore, it is not necessary to create a pressure differential across the open hoistway doors on the level of recall, because the recall floor will not be the floor of fire origin.

Cost Impact: The code change proposal will not increase the cost of construction.

FS140-12

Public Hearing:	Committee:	AS	AM	D
	Assembly:	ASF	AMF	DF

909.21.1-FS-PERRINO

FS141 – 12

909.21.1, 909.21.1.1(New)

Proponent: Jonathan Siu, representing City of Seattle Department of Planning & Development (jon.siu@seattle.gov)

Revise as follows:

909.21.1 Pressurization requirements. Elevator hoistways shall be pressurized to maintain a minimum positive pressure of 0.10 inches of water (25 Pa) and a maximum positive pressure of 0.25 inches of water (67 Pa) with respect to adjacent occupied space on all floors. This pressure shall be measured at the midpoint of each hoistway door, with all elevator cars at the floor of recall and all hoistway doors on the floor of recall open and all other hoistway doors closed. The pressure differentials shall be measured between the hoistway and the adjacent elevator landing. The opening and closing of hoistway doors at each level must be demonstrated during this test. The supply air intake shall be from an outside, uncontaminated source located a minimum distance of 20 feet (6096 mm) from any air exhaust system or outlet.

Exceptions:

1. On floors containing only Group R occupancies, the pressure differential is permitted to be measured between the hoistway and a dwelling unit or sleeping unit.
2. Where an elevator opens into a lobby enclosed in accordance with Sections 3007.7 or 3008.7, the pressure differential is permitted to be measured between the hoistway and the space immediately outside the door(s) from the floor to the enclosed lobby.
3. The pressure differential is permitted to be measured relative to the outdoor atmosphere on floors other than the following:
 - 3.1. The fire floor
 - 3.2. The two floors immediately below the fire floor, and
 - 3.3. The floor immediately above the fire floor

909.21.1.1 Use of Ventilation Systems. Ventilation systems, other than hoistway supply air systems, are permitted to be used to exhaust air from adjacent spaces on the fire floor, two floors immediately below, and one floor immediately above the fire floor to the building exterior where necessary to maintain the positive pressure relationships as required in 708.14.2.1 during the operation of the elevator shaft pressurization system.

Reason: The purpose of this code change proposal is to introduce a method of measuring pressure differentials in pressurized hoistways.

The City of Seattle has had a long history of requiring pressurized hoistways in high rise buildings to prevent smoke migration. In 2005, the City of Seattle Department of Planning & Development (DPD) convened a committee which included representatives from industry, the Seattle Fire Department, and DPD, to decide whether to recommend changes to the high rise smoke migration control requirements in place at that time. The committee also consulted with Dr. John Klote, who suggested the approach that Seattle eventually adopted with some small modifications. This proposal takes the Seattle approach and adapts it to the 2012 IBC.

During the 2009/2010 code change cycle, a proposal was made to delete the hoistway pressurization requirements in the IBC without substitution (FS51-09/10), based on a study conducted by Drs. Miller and Beasley. This study showed that requiring the pressure differential of 0.10 inches of water column to be maintained at the recall floor with the elevator doors in the open position resulted in overpressurization of all the other floors—meaning the current standards in the code cannot be met. Based on further modeling by Dr. Miller, the proponent for FS51 submitted a public comment introducing Seattle's requirements into the IBC. The reason statement for the public comment stated Dr. Miller "concluded that the 'Seattle approach' does indeed meet all the prescriptive requirements of the IBC 2009." The proposal and its public comment were ultimately withdrawn by the proponent in anticipation of the formation of the CTC Elevator Lobby Study Group.

While not specifically endorsed by the CTC Elevator Lobby Study Group, the Seattle approach was discussed as one of several viable options for preventing smoke from entering hoistways. Unfortunately, the Study Group did not recommend any changes to the prescriptive hoistway pressurization requirements currently in the code. DPD has chosen to submit this method because we believe the code needs a viable alternative to the currently unworkable requirements. It should be noted that this proposal is independent of the Study Group proposals, and will work regardless of the outcome of the proposals from the Study Group.

Specific changes:

The new text in Section 909.21.1 clarifies between which two points the pressure differential gets measured. In general, the intent of the code is to keep smoke out of the hoistway, so the pressure should be measured between the elevator hoistway and the elevator landing/lobby. However, the first exception allows the pressure to be measured between the hoistway and sleeping or dwelling units in residential buildings, since they are highly compartmented. In addition, the fire source is most likely to be in the dwelling or sleeping unit, and providing positive pressure in the corridor/hallway outside the units (via leakage through the elevator hoistway doors) will help reduce the smoke migrating from the affected unit. The second exception allows the pressure to be measured between the hoistway and the space on the outside the smoke barrier that forms the lobby.

The third exception is the key to this proposal, in that it requires the 0.10 inch water column pressure differential between the hoistway and the floor be met only on the 4 most critical floors—the floor of fire origin, the two floors immediately below, and one floor immediately above. For all other stories, the pressure differential is allowed to be measured between the hoistway and the outside of the building. The purpose of this requirement is to maintain a slightly positive pressure in the building relative to atmospheric, so as to lower the neutral pressure plane in the building, which then reduces the driving force of stack effect. This exception is intended to be permitted to be used in conjunction with Exceptions 1 and 2. The engineers who design this system begin by modeling one floor as the “notionalized” fire floor, and designing the system (fans, dampers, etc.) accordingly. Each floor is subsequently modeled as the notionalized fire floor, and the system is checked to make sure the maximum and minimum pressure differentials are met. (Note that actual models may not have to be run for each floor, if it is clear the worst case has been covered.) Ultimately, the system will need to be designed so it will correctly configure itself for a fire originating on any floor in the building.

New section 909.21.1.1 allows the use of the general building HVAC system to exhaust air to create/maintain the required pressure differential. It is to be noted that the requirements of the rest of Section 909.21, in particular, Section 909.21.10 regarding protection of equipment, would still apply to these components.

Cost Impact: This proposal will increase the cost of construction.

FS141-12

Public Hearing:	Committee:	AS	AM	D
	Assembly:	ASF	AMF	DF

909.21.1.1-FS-SIU

FS142 – 12

909.21.3, Chapter 35

Proponent: Tony Crimi, A.C. Consulting Solutions Inc, representing International Firestop Council (tcrimi@sympatico.ca)

Revise as follows:

909.21.3 Ducts for system. Any duct system that is part of the pressurization system shall be protected with the same *fire-resistance rating* as required for the elevator shaft enclosure.

Exception: Ducts tested and listed for not less than 2-hour fire-resistance in accordance with ASTM E2816 are permitted.

Add new standard to Chapter 35 as follows:

ASTM

E2816-11, Standard Test Methods for Fire Resistive Metallic HVAC Duct Systems.

Reason: This proposal permits an additional exception to the requirement to install fire dampers in duct and air transfer openings through fire barriers provided the HVAC ducts are protected by a tested and listed assembly conforming to the new *ASTM E2816-11, Standard Test Methods for Fire Resistive Metallic HVAC Duct Systems* evaluated for the specific purpose. This test is now also referenced as part of ICC-ES AC179, Acceptance Criteria for Metallic HVAC Duct Enclosure Assemblies. The purpose of these acceptance criteria is to establish requirements for fire protection enclosure systems applied to metallic HVAC ducts, which provides an alternate to required fire-resistance-rated shafts or an alternate to required fire dampers in specific locations. This criteria provides an alternate to shaft enclosures for vertical ducts.

This principle of protecting HVAC ducts used as part of a smoke control system from the effects of fire exposure is also already contained in section 909.4.4 which requires that the design consider the effects of the heating, ventilating and air-conditioning (HVAC) systems on both smoke and fire transport. The analysis must include all permutations of systems status, and the design shall consider the effects of the fire on the HVAC systems.

The ASTM test method achieves this by evaluate the ability of a HVAC duct system to resist the spread of fire from one compartment to other compartments separated by a fire resistance rated construction when the HVAC duct system is exposed to fire under one or more of the following conditions:

- Condition A*— Fire exposure from the outside of the horizontal HVAC duct system without openings,
- Condition B*— Fire exposure from the outside of the vertical HVAC duct system without openings,
- Condition C*— Fire exposure from the outside with hot gases entering the inside of the horizontal HVAC duct system with unprotected openings, and
- Condition D*— Fire exposure from the outside with hot gases entering the inside of the vertical HVAC duct system with unprotected openings.

The new ASTM Standard evaluates the HVAC duct systems for surface burning characteristics, non-combustibility, fire resistance, durability, and fire engulfment with horizontal and vertical through-penetration firestops. The Standard can evaluate the fire performance of HVAC ducts for both supply (pressurization) and return air, in the vertical and horizontal orientation, with or without openings. These test methods evaluate the ability of a HVAC duct system to resist the spread of fire from one compartment to another compartment when subjected to the standard time-temperature curve of ASTM E119.

Cost Impact: This change will potentially reduce the cost of construction.

Analysis: FS58, Part V and FS 142 contain similar requirements for elevator hoistway pressurization. The committee needs to make its intent clear with respect to these provisions. A review of the standard proposed for inclusion in the code, ASTM E2816-11 with regard to the ICC criteria for referenced standards (Section 3.6 of CP#28) will be posted on the ICC website on or before April 2, 2012.

FS142-12

Public Hearing:	Committee:	AS	AM	D
	Assembly:	ASF	AMF	DF

909.21.3-FS-CRIMI

FS143 – 12
909.21.4, 909.21.4.5 (New)

Proponent: Bill Ziegert, Smoke Guard, Inc representing self

Revise as follows:

909.21.4 Fan system. The fan system provided for the pressurization system shall be as required by Sections 909.21.4.1 through ~~909.21.4.4~~ 909.21.4.5.

909.21.4.5 Pressurization Air Temperature. The temperature of elevator shaft pressurization air shall comply with Section 2.7.9.2 of ASME A17.1.

Reason: This proposal clarifies that when the elevator shaft pressurization option is chosen in lieu of fully enclosed elevator lobbies when required by the code, that the pressurization air shall not negatively impact elevator equipment. The Elevator Code restricts that ambient air temperature in elevator machine rooms and control spaces to be within the range specified by the elevator manufacturer which is typically 40 – 105 degrees Fahrenheit.

With the advent of machine room less elevators, the control equipment is often with the elevator shaft. This requirement would insure that elevator shaft pressurization air is conditioned to the levels required by the elevator manufacturer. This is particularly important since pressurization systems will at times be running at the same time as elevator operation including both Pre – Phase 1 and during Phase 2 when the Fire Service may be using the elevator systems to move equipment and personnel and elevator reliability is particularly critical.

Cost Impact: In colder climates this may require conditioning systems to be added to the pressurization intake.

FS143-12

Public Hearing:	Committee:	AS	AM	D
	Assembly:	ASF	AMF	DF

909.21.4.5 (NEW)-FS-ZIEGERT

FS144 – 12

1403.2, 1404.2

Proponent: Jonathan Humble, AIA, NCARB, LEED AP-BD&C, American Iron and Steel Institute representing: American Iron and Steel Institute and the Metal Building Manufacturers Association (Jhumble@steel.org)

Revise as follows:

1403.2 Weather protection. Exterior walls shall provide the building with a weather-resistant *exterior wall envelope*. The *exterior wall envelope* shall include flashing, as described in Section 1405.4. The *exterior wall envelope* shall be designed and constructed in such a manner as to prevent the accumulation of water within the wall assembly by providing a means for draining water that enters the wall assembly to the exterior, or by providing an exterior wall covering which acts as both a weather-resistant and water-resistive barrier. ~~A a water-resistive barrier behind the exterior veneer,~~ as described in Section 1404.2, shall be provided behind the exterior veneer of a veneered *exterior wall envelope* ~~and a means for draining water that enters the assembly to the exterior.~~ Protection against condensation in the *exterior wall* assembly shall be provided in accordance with Section 1405.3.

Exceptions: (*Portions of text remain unchanged*)

1404.2 Water-resistive barrier. A minimum of one layer of No.15 asphalt felt, complying with ASTM D 226 for Type 1 felt or other *approved* materials, shall be attached to the studs or sheathing of a veneered system, with flashing as described in Section 1405.4, in such a manner as to provide a continuous *water-resistive barrier* behind the *exterior wall veneer*.

Reason: This code change proposes to modify Section 1403.2 in two places. The intent is to resolve the confusion of metal wall systems versus veneered wall assemblies.

The intent of the modifications is to make clear the fundamental requirement for providing a means for draining water that enters a veneered or non-veneered wall assembly by moving this requirement to the preceding sentence that focuses on the prevention of accumulation of water within the wall assembly.

This modification also clarifies that the requirement for a water-resistive barrier is only applicable to a veneered system. We propose to allow those non-veneered systems to be exempted from the requirement for a water-resistive barrier as that is redundant. For example, the traditional non-veneered walls used for an engineered metal building utilize an exterior metal cladding attached to girts and a water-resistive barrier behind this exterior metal cladding is not required as the metal skin acts both as the weather-resistant barrier and water-resistive barrier. Another non-veneered example is the metal composite material system or insulated metal panel wall system which also serves in a similar capacity. The MCM and IMP systems constitute another type of metal cladding system where the edges of the panels are both interlocked and gasketed, thus acting as both a weather-resistant barrier and water-resistive barrier.

The remaining provisions of Section 1403.2 remain unchanged.

The change in Section 1404.2 is for clarification and coordination with the changes in Section 1403.2.

Cost Impact: No impact to the cost of construction is anticipated.

FS144-12

Public Hearing:	Committee:	AS	AM	D
	Assembly:	ASF	AMF	DF

1403.2-FS-HUMBLE

FS145 – 12

1403.2

Proponent: Theresa Weston, PhD., representing DuPont Building Innovations
(theresa.a.weston@usa.dupont.com)

Revise as follows:

1403.2 Weather protection. Exterior walls shall provide the building with a weather-resistant *exterior wall envelope*. The *exterior wall envelope* shall include flashing, as described in Section 1405.4. The *exterior wall envelope* shall be designed and constructed in such a manner as to prevent the accumulation of water within the wall assembly by providing a *waterresistive barrier* behind the exterior veneer, as described in Section 1404.2, and a means for draining water that enters the assembly to the exterior. In areas with an average annual rainfall exceeding 35 inches, walls shall have an average minimum drainage efficiency of 75 percent when tested in accordance the requirements of ASTM E 2273. Protection against condensation in the *exterior wall* assembly shall be provided in accordance with Section 1405.3.

Exception: (No change to current text)

Reason: This proposal adds a method of measuring drainage to the requirement for a means of drainage for high rainfall areas. Drainage is an important component of managing water, especially under high rainfall/ exposure conditions, such as those in the Pacific Northwest (Portland, OR 43.5" avg, Seattle, WA 37.7" avg.). Drainage requirements, including the proposed requirement, have been included in the Oregon State Residential Code.

Cost Impact: The code change proposal will increase the cost of construction in locations with high rainfall.

FS145-12

Public Hearing: Committee:	AS	AM	D
Assembly:	ASF	AMF	DF

1403.2-FS-WESTON

FS146 – 12

1403.3.1 (New)

Proponent: Edward L. Keith, P.E., representing APA – The Engineered Wood Association.
(ed.keith@apawood.org)

THIS CODE CHANGE WILL BE HEARD BY THE IBC-STRUCTURAL COMMITTEE. SEE THE TENTATIVE HEARING ORDER FOR THIS COMMITTEE.

Add new text as follows:

1403.3 Structural. *Exterior walls*, and the associated openings, shall be designed and constructed to resist safely the superimposed loads required by Chapter 16.

1403.3.1 Structural capacity of an assembly. Where the exterior wall covering and the backing materials are designed to resist wind loads together as an assembly, the opaque exterior wall, including gable ends, shall be constructed as an assembly with required backing materials.

Reason: There are a number of wall constructions promoted today for use in exterior wall applications that use the code recognized assembly approach to resist wind loads normal (acting perpendicular) to the exterior walls. The assembly approach recognizes that in a properly assembled wall system, the applied wind loads are distributed to a number of different wall components. These components may include the exterior siding, sheathing and interior gypsum wall board finish. The performance of the wall system is dependent on each of the component members being properly installed and present during the wind event. The assembly systems can only resist the design wind load when this is the case as each component carries some part of the load. Loss of a single layer of the assembly can mean the failure of that portion of wall.

The code change is proposed to clarify that when such systems are used that they must be used on all areas of the exterior wall including the gable-end walls. Surveys of wind storm damage over the last few years have consistently shown that gable end walls are one of the most common areas where breaches in the building envelope occur, in many cases at wind speeds much lower than the code design wind speed. It often does not occur to the builder that the use of gypsum wall board is a requisite part of the wall assembly when cladding the gable-end walls. Lacking the interior gypsum wall board sheathing, the incomplete wall assemblies are often unable to resist the applied wind loads. This leads to the loss of the structural and weather resistance of the gable end. Loss of the gable-end cladding and the resulting pressurization of the building envelope often lead to more severe structural failures to the roof system, as well as water damage to the interior of the structure.

A recently published article in the Journal of Structural Engineering (August 5, 2011) entitled *Effects of Pressure Equalization on the Performance of Residential Wall Systems under Extreme Wind Loads*, by G. A. Kopp and E. Gavanski, is one of the most recent articles that recognize the susceptibility of structural wall assemblies to failure when any one of the assembly components is compromised or eliminated.

Cost Impact: The code change proposal will not increase the cost of construction.

FS146-12

Public Hearing:	Committee:	AS	AM	D
	Assembly:	ASF	AMF	DF

1403.3.1 (NEW)-FS-KEITH

FS147 – 12

1403.5

Proponent: Theresa Weston, PhD., representing DuPont Building Innovations
(theresa.a.weston@usa.dupont.com)

Revise as follows:

1403.5 Vertical and lateral flame propagation. Exterior walls on buildings of Type I, II, III or IV construction that are greater than 40 feet (12 192 mm) in height above grade plane and contain a combustible water-resistive barrier shall be tested in accordance with and comply with the acceptance criteria of NFPA 285.

Exception: Walls that contain less than 500 gm/m² combustible material and where the water-resistive barrier has a flame spread index of 25 or less and a smoke-developed index of 450 or less as determined in accordance with ASTM E 84 or UL 723.

Reason: Section 1403.5 (new in 2012) requires NFPA 285 testing for exterior walls containing a combustible water-resistive barrier. Since walls are required by Section 1402.3 to incorporate a water-resistive barrier and virtually all water-resistive barriers currently on the market are combustible, the introduction of this section into the code is requiring testing of all walls. This proposal exempts walls in which the only combustible material is a water-resistive barrier with low flame spread and low mass so that it will have an insignificant contribution to the total fuel load of the wall system.

Cost Impact: The code change proposal will not increase the cost of construction.

Analysis: FS14 7 revised the provisions for flame propagation in noncombustible exterior walls. FS148 deletes these requirements. The committee needs to make its intent clear with respect to these provisions.

FS147-12

Public Hearing:	Committee:	AS	AM	D
	Assembly:	ASF	AMF	DF

1403.5-FS-WESTON

FS148 – 12

1403.5

Proponent: David S. Collins, FAIA, The Preview Group, Inc., representing The American Institute of Architects (dcollins@preview-group.com); Henry Green, President, National Institute of Building Sciences, representing NIBS BETEC Committee (hgreen@nibs.org)

Delete without substitution:

~~**1403.5 Vertical and Lateral Flame Propagation.** Exterior walls on buildings of Type I, II, III or IV construction that are greater than 40 feet (12 192 mm) in height above grade plane and contain a combustible water resistive barrier shall be tested in accordance with and comply with the acceptance criteria of NFPA 285.~~

Reason: There are materials that are available, tried and tested by long-term proven history of performance as weather barriers that are not able to meet the standards in this test. Section 1403.2 of the IBC requires weather-resistive barriers while Section 1403.5 requires them to be tested to a standard if they contain a combustible water resistive barrier that many materials that are traditionally used and have proven their value can't meet.

Section 2603.5 establishes requirements for protection and testing of combustible water resistive barriers that include foam plastic insulation, so Section 1403.5 is not necessary for those products. Given that 75% of construction litigation relates to water leakage suggests that this paragraph should be deleted or we are likely to face significant problems in the future with the failure of exterior water barriers.

Cost Impact: The change will reduce the cost of construction.

Analysis: FS14 7 revised the provisions for flame propagation in noncombustible exterior walls. FS148 deletes these requirements. The committee needs to make its intent clear with respect to these provisions.

FS148-12

Public Hearing:	Committee:	AS	AM	D
	Assembly:	ASF	AMF	DF

1403.5-FS-COLLINS-GREEN

FS149 – 12

1403.6 (New), Chapter 35

Proponent: Marcelo M. Hirschler, GBH International (gbhint@aol.com); Sean DeCrane, representing Cleveland Fire Department/International Association of Fire Fighters (rovloc93@aol.com)

Add new text as follows:

1403.6 Resistance to Radiant Heat. Exterior walls on buildings of Type V construction that are greater than 20 feet (6096 mm) in height above grade plane, contain combustible components and are not required to exhibit a fire resistance rating shall be tested in accordance with ASTM E2707 and demonstrate absence of flame penetration through the wall assembly at any time during the test and absence of evidence of glowing combustion on the interior surface of the assembly at the end of the test.

Exceptions:

1. Exterior walls that comply with NFPA 285.
2. Exterior walls that comply with FM 4880.
3. Exterior walls that comply with UL 1040.
4. Exterior walls that exhibit a 1 hour fire resistance rating if tested to ASTM E119 or UL 263.
5. The fire separation distance to the adjacent building is no less than 10 feet (3048 mm).

(Renumber subsequent sections)

Add new standard to Chapter 35 as follows:

ASTM

E2707 (2009), Standard Test Method for Determining Fire Penetration of Exterior Wall Assemblies Using a Direct Flame Impingement Exposure.

Reason: The requirements for insulation of buildings of Type V construction are increasing to such an extent that there will be a significantly increased use of combustible insulation materials as part of exterior walls. If we believe that these buildings are not just "built to burn down" we need to consider protecting them from radiant heat generated by neighboring buildings.

ASTM E2707 was developed specifically for this purpose. It assesses whether the wall resists a radiant exposure of 150 kW for 10 minutes. The conditions of acceptance are not in the mandatory part of the standard but in section X1.2.10, which is a non mandatory appendix and are therefore needed in the code.

The exceptions are for walls that comply with a severe fire test (or have a fire resistance rating) already: they don't need to be retested. Note that NFPA 285, FM 4880 and UL 1040 are all severe fire tests that were specifically designed to assess the fire performance of exterior walls containing combustible materials.

If the walls have not been tested the separation distance must be increased to lower the risk of radiant heat ignition from the neighboring building.

Note that exterior walls for buildings of Type VB construction are not required to comply with a fire resistance rating in accordance with ASTM E119 or UL 263 (see Tables 601 and 602). Also, exterior walls for buildings of Type VA construction are permitted to be exempt from complying with a fire resistance rating if the building is sprinklered. The sprinklers will protect the interior of the building but will have no effect on the radiated heat released externally by the burning wall, which can then potentially affect neighboring buildings.

Cost Impact: Minimal

FS149-12

Public Hearing:	Committee:	AS	AM	D
	Assembly:	ASF	AMF	DF

1403.6 (NEW)-FS-DECRANE-HIRSCHLER

FS150 – 12

1403.6

Proponent: Philip Line, American Wood Council, representing American Wood Council

Revise as follows:

1403.6 Flood resistance. For buildings in flood hazard areas as established in Section 1612.3, *exterior walls* extending below the elevation required by Section 1612 shall be constructed with flood-damage-resistant materials. ~~Wood shall be pressure-preservative treated in accordance with AWPA U1 for the species, product and end use using a preservative listed in Section 4 of AWPA U1 or decay-resistant heartwood of redwood, black locust or cedar.~~

Reason: The specific requirement for preservative treated wood in *exterior walls* extending below the base flood elevation is deleted because wood products such as plywood sheathing, plywood panel siding and wall studs have been shown to be resistant to effects of flood exposure without aid of preservatives required elsewhere in the code for protection of wood from decay and termites.

Primary considerations for material performance and use in flood hazard areas are outlined in FEMA *TB2 Flood Damage Resistant Materials Requirements for Buildings Located in Special Flood Hazard Areas*. A flood damage resistant material is one that is “capable of withstanding direct and prolonged contact with floodwaters without sustaining significant damage”. Evaluation consists of consideration of material performance following 72 hr immersion and presence of only limited damage requiring no more than cosmetic repair (e.g. cleaning, sanitizing, and resurfacing such as sanding, repair of joints, repainting). Research conducted by Oak Ridge National Laboratory and Tuskegee University (ORNL/TM-2005/34 Field Testing of Energy-Efficient Flood-Damage-Resistant Residential Envelope Systems Summary Report, June 2004) and field observations of material performance from actual floods were considerations in the update of FEMA TB2-2008. Within TB2, examples of wood that are not required to be preservative treated for flood damage resistance that may form a part of *exterior walls* include studs and Exterior and Marine Plywood used as wall sheathing. While preservative treated studs and preservative treated exterior plywood sheathing were not tested in the ORNL/Tuskegee study, it is not expected that presence of preservative treatment would improve the already acceptable performance of these materials.

Requirements for preservative treated wood for protection from decay and termites are addressed elsewhere in the code (see 2303.1.8, 2304.11 and Chapter 18) and will continue to be in effect including in flood hazard areas. These include required preservative treatment of: i) wood framing members, including wood sheathing, that rest on exterior foundation walls and are less than 8 inches from exposed earth, ii) wood framing members and furring strips attached directly to the interior of exterior masonry or concrete walls below grade, iii) sleepers and sills on a concrete or masonry slab that is in direct contact with earth, iv) wood siding where clearance is less than 6 inches from earth or less than 2 inches horizontal surfaces such as concrete porch or similar surface, and v) wood in contact with ground.

A similar requirement for preservative-treated wood along with reference to FEMA TB2 is in the 2012 IRC. A companion change to this proposal will be submitted to the IRC to make provisions of the IRC and IBC consistent.

FS150-12

Public Hearing:	Committee:	AS	AM	D
	Assembly:	ASF	AMF	DF

1403.6-FS-LINE

FS151 – 12

1404.2, Chapter 35

Proponent: Theresa Weston, PhD., representing DuPont Building Innovations
(theresa.a.weston@usa.dupont.com)

Revise as follows:

1404.2 Water-resistive barrier. A minimum of one layer of ~~No. 15 asphalt felt~~ water-resistive barrier, complying with ASTM ~~D 226 for Type 1 felt~~ E 2556 or other *approved* materials, shall be attached to the studs or sheathing, with flashing as described in Section 1405.4, in such a manner as to provide a continuous *water-resistive barrier* behind the *exterior wall veneer*.

Add new standard to Chapter 35 as follows:

ASTM
E2556-10 Standard Specification for Vapor Permeable Flexible Sheet Water-Resistive Barriers Intended for Mechanical Attachment

Reason: The proposal updates the water-resistive barrier reference to the most recent consensus standard. ASTM E2556 includes housewrap materials, building papers and felt, instead of just felt and therefore is more representative of the state of the industry. ASTM E2556 is consistent with the current ICC-ES acceptance criteria for water-resistive barriers (AC-38) and therefore should not limit the use of current WRBs.

Cost Impact: The code change proposal will not increase the cost of construction.

Analysis: A review of the standard proposed for inclusion in the code, ASTM E2556-10 with regard to the ICC criteria for referenced standards (Section 3.6 of CP#28) will be posted on the ICC website on or before April 2, 2012.

FS151-12

Public Hearing:	Committee:	AS	AM	D
	Assembly:	ASF	AMF	DF

1404.2-FS-WESTON

FS152 – 12

1404.2, 1405.4 (New)

Proponent: Jay Crandell, ARES Consulting, representing the Foam Sheathing Committee of the American Chemistry Council- Plastics Division (jcrandell@aresconsulting.biz)

Revise as follows:

1404.2 Water-resistive barrier. A water-resistive barrier material shall be a minimum of one layer of No.15 asphalt felt, complying with ASTM D 226 for Type 1 felt, Grade D paper in accordance with Section 2510.6, or other approved materials and installations performance tested for water resistance and durability and determined to be at least equivalent to a typical installation of No. 15 asphalt felt over a continuous substrate. At a minimum, water resistance tests of the water-resistive barrier installation without cladding installed shall be conducted using ASTM E 331 with a minimum 15 minute test duration and a minimum 2.86 psf (137 Pa) pressure differential using minimum 4-foot (1.2 m) by 8-foot (2.4 m) wall specimens including at least one horizontal and one vertical joint with joints and attachments installed in the manner intended for end use, shall be attached to the studs or sheathing, with flashing as described in Section 1405.4, in such a manner as to provide a continuous water-resistive barrier behind the exterior wall veneer. Where water-resistive barriers are evaluated as part of a wall assembly with cladding installed, the water resistance performance testing provisions of Section 1403.2 exception 2 shall apply.

1405.4 Water-resistive barrier. Water-resistive barrier materials and flashing shall be installed in such a manner as to provide a continuous water-resistive barrier behind the exterior wall cladding. Where No. 15 asphalt felt complying with ASTM D226 for Type 1 felt is used as a water-resistive barrier material, a minimum of one layer shall be required with minimum 2-inch (51 mm) horizontal shingle-style lap joints and minimum 6-inch (152 mm) vertical lap joints. No. 15 asphalt felt and other approved membrane-type water-resistive barrier materials shall be attached to sheathing for backing or an approved water-resistive barrier sheathing installation shall be used.

(Renumber subsequent sections)

Reason: Current section 1404.2 includes installation requirements as well as material requirements while Section 1404 Materials is meant to apply to materials only. Installation requirements for exterior wall covering assembly components or materials are intended to be addressed in Section 1405. Therefore, this proposal moves installation requirements from Section 1404.2 to a new Section 1405.4, just ahead of existing section 1405.4 which deals with the closely associated requirements for flashing installation. Material requirements only are retained in Section 1404.2 and the performance requirement for “other approved materials” is clarified to ensure equivalency to No. 15 felt which defines the traditional benchmark for WRBs. Performance testing requirements for alternatives are clarified for the case when the WRB is tested without cladding installed. In addition, installation requirements for No. 15 felt and other membrane WRBs are strengthened in proposed Section 1405.4 by requiring installation over sheathing to ensure lap joints remain closed and wind pressure fluctuations do not create a “pumping effect” drawing air in and out of the wall cavity.

Cost Impact: The code change proposal will not increase the cost of construction.

FS152-12

Public Hearing:	Committee:	AS	AM	D
	Assembly:	ASF	AMF	DF

1404.2-FS-CRANDELL

FS153 – 12

202 (New), 1402.1, 1404.3 (New), 1405.5 (New)

Proponent: Jay Crandell, ARES Consulting, representing the Foam Sheathing Committee of the American Chemistry Council- Plastics Division (jcrandell@aresconsulting.biz)

Add new definition as follows:

SECTION 202 DEFINITIONS

AIR BARRIER. Material(s) assembled and joined together to provide a barrier to air leakage through the building envelope. An air barrier may be a single material or a combination of materials.

Revise as follows:

1402.1 Definitions. The following terms are defined in Chapter 2:

ADHERED MASONRY VENEER.

AIR BARRIER

ANCHORED MASONRY VENEER.

BACKING.

EXTERIOR INSULATION AND FINISH SYSTEMS (EIFS).

EXTERIOR INSULATION AND FINISH SYSTEMS (EIFS) WITH DRAINAGE.

EXTERIOR WALL.

EXTERIOR WALL COVERING.

EXTERIOR WALL ENVELOPE.

FIBER-CEMENT SIDING.

HIGH-PRESSURE DECORATIVE EXTERIOR-GRADE COMPACT LAMINATE (HPL).

HIGH-PRESSURE DECORATIVE EXTERIOR-GRADE COMPACT LAMINATE (HPL) SYSTEM.

METAL COMPOSITE MATERIAL (MCM).

METAL COMPOSITE MATERIAL (MCM) SYSTEM.

POLYPROPYLENE SIDING.

PORCELAIN TILE.

VENEER.

VINYL SIDING.

WATER-RESISTIVE BARRIER.

1404.3 Air barriers. Air barrier materials shall comply with Section C402.4.1.2.1 of the *International Energy Conservation Code*. Air barrier wall assemblies shall comply with Section C402.4.1.2.2 of the *International Energy Conservation Code*.

(Renumber subsequent sections)

1405.5 Air barrier installation. Air barriers shall be provided and installed in exterior walls in accordance with Section C402.4.1.1 of the *International Energy Conservation Code* and the additional requirements of this section. An air barrier shall be provided in or by an exterior wall assembly. Where using air permeable cavity insulation in an exterior frame wall assembly, air barriers shall be provided on both the inside and outside face of the wall cavity. Where air-barriers are installed on the exterior side of an exterior wall, it shall be a sheathing material or placed on a sheathing material for backing.

(Renumber subsequent sections)

Reason: Air barriers should not just be a requirement for energy code compliance from the standpoint of controlling overall building air leakage. Air barriers also play an important role in controlling access of warm, moist air into building cavities where they can condensate on cold surfaces (exterior surface in cold climates or interior surface of cavity in warm/humid climates). In this regard,

air barriers should be considered as important as vapor retarders which are addressed in current Section 1405.3 of the IBC. Air barriers also provide wall boundary conditions (interior and exterior surfaces) for air permeable cavity insulation products to ensure that they perform as intended and in a condition that is consistent with the basis of insulation material thermal property testing. Thus, it is important to include air barriers in the IBC to address their role in a manner that compliments the IECC. With the above purpose in mind, this proposal coordinates with and builds on information and requirements already found in the IECC. The definition is directly from the IECC.

Cost Impact: The code change proposal will not increase the cost of construction.

FS153-12

Public Hearing:	Committee:	AS	AM	D
	Assembly:	ASF	AMF	DF

1404.3 (NEW)-FS-CRANDELL

FS154 – 12

1404.4

Proponent: John Woestman, Kellen Company, representing Masonry Veneer Manufacturers Association (MVMA) (jwoestman@kellencompany.com)

Revise as follows:

1404.4 Masonry. Exterior walls of masonry construction shall be designed and constructed in accordance with this section and Chapter 21. Masonry units, mortar and metal accessories used in anchored and adhered veneer shall meet the physical requirements of Chapter 21. The backing of anchored and adhered veneer shall be of concrete, masonry, steel framing or wood framing. Insulation board meeting the applicable requirements of the code shall be permitted between the backing and the masonry veneer.

Reason: Section 1404.4 could be interpreted as not allowing continuous insulation / insulation board to be placed in the wall system between the masonry veneer and the backing.

Cost Impact: None

FS154-12

Public Hearing:	Committee:	AS	AM	D
	Assembly:	ASF	AMF	DF

1404.4-FS-WOESTMAN

FS155 – 12

1404.5

Proponent: Bonnie Manley, P.E., American Iron and Steel Institute (bmanley@steel.org)

Revise as follows:

1404.5 Metal. Exterior walls ~~constructed of cold-formed steel construction,~~ structural steel or ~~aluminum lightweight metal alloys~~ shall be designed in accordance with Chapters 22 and 20, respectively.

Reason: These minor editorial modifications in this section correct the terminology related to cold-formed steel and aluminum to match that utilized in Chapter 22, Section 2210 and Chapter 20.

Cost Impact: No impact to the cost of construction is anticipated.

FS155-12

Public Hearing:	Committee:	AS	AM	D
	Assembly:	ASF	AMF	DF

1404.5-FS-MANLEY

FS156 – 12

1404.10, Chapter 35

Proponent: John Mulder, Intertek Testing Services NA, Inc., representing International Standards Organization Technical Committee 77, Products in Fibre-reinforced Cement and self

Revise as follows:

1404.10 Fiber-cement siding. Fiber-cement siding shall conform to the requirements of ASTM C1186, Type A (or ISO 8336, Category A), and shall be so identified on labeling listing an *approved* quality control agency.

Add new standard to Chapter 35 as follows:

ISO
8336-2009 Fiber-Cement Flat Sheets – Product Specification and Test Methods

Reason: Performance requirements of ISO 8336, *Fibre-cement flat sheets – Product specification and test methods*, have been harmonized with the performance requirements of ASTM C1186. Fiber-cement siding producers in Mexico, Central and South America, Europe, Asia, Australia and New Zealand currently manufacture and test their fiber-cement siding products for compliance with ISO 8336 (see attached). Members of International Standards Organization Technical Committee 77, *Product in Fibre-reinforced Cement*, are working to have their respective country's codes, where applicable, revised to include the harmonized standard. The inclusion of this Standard in the IBC will eliminate a barrier to trade by permitting manufacturers worldwide to demonstrate compliance with product performance requirements specific to the United States without incurring the added expense of additional test report documentation.

Cost Impact: The code change proposal will not increase the cost of construction because the recognition of the alternative compliance Standard can reduce test report documentation requirements thereby reducing costs to the product manufacturer and reduces a barrier to trade.

Analysis: A review of the standard proposed for inclusion in the code, ISO 8336-2009, with regard to the ICC criteria for referenced standards (Section 3.6 of CP#28) will be posted on the ICC website on or before April 2, 2012.

FS156-12

Public Hearing:	Committee:	AS	AM	D
	Assembly:	ASF	AMF	DF

1404.10-FS-MULDER

FS157 – 12

1404.13 (New)

Proponent: Jay Crandell, ARES Consulting, representing the Foam Sheathing Committee of the American Chemistry Council- Plastics Division (jcrandell@aresconsulting.biz)

Add new text as follows:

1404.13 Foam Plastic Insulation. Foam plastic insulation used in exterior wall covering assemblies shall comply with Section 2603.

Reason: Foam plastic insulation is commonly included as a component in exterior wall covering assemblies for energy code compliance and is included in the current definition of exterior wall coverings. Therefore, it is appropriate to include in Chapter 14 reference to applicable material requirements in Chapter 26.

Cost Impact: The code change proposal will not increase the cost of construction.

FS157-12

Public Hearing:	Committee:	AS	AM	D
	Assembly:	ASF	AMF	DF

1404.13 (NEW)-FS-CRANDELL

FS158 – 12

1405.1

Proponent: Jay Crandell, ARES Consulting, representing the Foam Sheathing Committee of the American Chemistry Council- Plastics Division (jcrandell@aresconsulting.biz)

Revise as follows:

1405.1 General. *Exterior wall coverings* shall be designed and constructed in accordance with the applicable provisions of this section. Where foam plastic insulation is included in an exterior wall covering assembly, the installation shall comply with the applicable provisions of Chapter 26 in addition to the requirements of this section.

Reason: Insulation is appropriately included in the definition of exterior wall coverings. When foam plastic insulation is included as a component in an exterior wall covering assembly, additional requirements for the foam sheathing as well as the exterior wall covering assembly and also the wall system apply and are found in Chapter 26. This proposal makes a proper linkage to those requirements in Chapter 26.

Cost Impact: The code change proposal will not increase the cost of construction.

FS158-12

Public Hearing:	Committee:	AS	AM	D
	Assembly:	ASF	AMF	DF

1405.1-FS-CRANDELL

FS159 – 12

1405.3

Proponent: Randall R. Dahmen, P.E. Wisconsin licensed Commercial Building Inspector, representing self

Revise as follows:

1405.3 Vapor retarders. Class I or II vapor retarders shall be provided on the interior side of frame walls in Zones 5, 6, 7, 8 and Marine 4. The appropriate zone shall be selected in accordance with Chapter 3 of the *International Energy Conservation Code*.

Exceptions:

1. Basement walls.
2. Below-grade portion of any wall.
3. Construction where moisture or its freezing will not damage the materials.
4. Box sills.
5. Where other approved means to avoid condensation in unventilated framed wall, floor, roof and ceiling cavities are provided.

Reason: There are situations in which a vapor retarder is not a viable installation. In the situation of open box sills, commonly located above a basement drop ceiling, access is limited, and thus the ability to properly install a vapor retarder in a box sill is also limited. To require vapor retarder for such spaces is not practical.

Additionally, there are a multitude of wall products and wall configurations which may provide a means to avoid condensation in unventilated framed wall, floor, roof and ceiling cavities, however, the current language does not allow for recognition of them. The intent of the proposed exception is to allow for design flexibility.

Please note that the submitter would accept the inclusion of one of the proposed exceptions without the inclusion of the other.

Cost Impact: The code change proposal will not increase the cost of construction.

FS159-12

Public Hearing:	Committee:	AS	AM	D
	Assembly:	ASF	AMF	DF

1405.3-FS-DAHMEN

FS160 – 12

1405.3, 1405.3.1, Table 1405.3.1, 1405.3.2

Proponent: Jay Crandell, ARES Consulting, representing the Foam Sheathing Committee of the American Chemistry Council- Plastics Division (jcrandell@aresconsulting.biz)

Revise as follows:

1405.3 Vapor retarders. Vapor retarders as described in Section 1405.3.3 shall be provided in accordance with Sections 1405.3.1 and 1405.3.2, or an approved design using accepted engineering practice for hygrothermal analysis.

1405.3.1 Class I and II Vapor Retarders. Class I or II vapor retarders shall not be provided on the interior side of frame walls in Zones 1 and 2. Class I vapor retarders shall not be provided on the interior side of frame walls in Zones 3 and 4. Class I or II vapor retarders shall be provided on the interior side of frame walls in Zones 5, 6, 7, 8 and Marine 4. The appropriate zone shall be selected in accordance with Chapter 3 of the *International Energy Conservation Code*.

Exceptions:

1. Basement walls.
2. Below-grade portion of any wall.
3. Construction where moisture or its freezing will not damage the materials.
4. Conditions where Class III vapor retarders are required in Section 1405.3.2.

1405.3.1.2 Class III vapor retarders. Class III vapor retarders shall be permitted where any one of the conditions in Table 1405.3.1 is met. Only Class III vapor retarders shall be used on the interior side of frame walls where foam plastic insulating sheathing with perm rating of less than 1 perm is applied in accordance with Table 1405.3.1 on the exterior side of the frame wall.

**TABLE 1405.3.1
CLASS III VAPOR RETARDERS**

(Portions of table not shown remain unchanged)

- a. Spray foam with a minimum density of 2 lbs/ft³ applied to the interior cavity side of wood structural panels, fiberboard, insulating sheathing or gypsum is deemed to meet the insulating sheathing requirement where the spray foam *R*-value meets or exceeds the specified insulating sheathing *R*-value.

~~1405.3.2~~ 1405.3.3 Material vapor retarder class. The *vapor retarder class* shall be based on the manufacturer's certified testing or a tested assembly. The following shall be deemed to meet the class specified:

- Class I: Sheet polyethylene, nonperforated aluminum foil with a perm rating of less than or equal to 0.1.
- Class II: Kraft-faced fiberglass batts or paint with a perm rating greater than 0.1 and less than or equal to 1.0.
- Class III: Latex or enamel paint with a perm rating of greater than 1 and less than or equal to 10.

Reason: Provisions are strengthened and clarified to better promote seasonal drying of walls and avoid a "double vapor barrier" condition in combination with a "warm wall" design using insulating sheathing in cold climates. Provision is also added to clarify that low perm vapor retarders on interior side of walls shall not be used in the warmer climate zones as indicated to avoid a reversed vapor retarder. In essence the code says well what "ought" to be done, but doesn't clearly prohibit what "ought not" be done.

Cost Impact: The code change proposal will not increase the cost of construction.

FS160-12

Public Hearing:	Committee:	AS	AM	D
	Assembly:	ASF	AMF	DF

1405.3-FS-CRANDELL

FS161 – 12

1405.4, Chapter 35

Proponent: Theresa Weston, PhD., representing DuPont Building Innovations
(theresa.a.weston@usa.dupont.com)

Revise as follows:

1405.4 Flashing. Flashing shall be installed in such a manner so as to prevent moisture from entering the wall or to redirect it to the exterior. Flashing shall be installed at the perimeters of exterior door and window assemblies, penetrations and terminations of *exterior wall* assemblies, *exterior wall* intersections with roofs, chimneys, porches, decks, balconies and similar projections and at built-in gutters and similar locations where moisture could enter the wall. Flashing with projecting flanges shall be installed on both sides and the ends of copings, under sills and continuously above projecting *trim*. When self-adhered membranes are used as flashing, those self-adhered flashings shall comply with AAMA 711. When fluid applied membranes are used as flashing, those fluid applied membrane flashings shall comply with AAMA 714.

Add new standards to Chapter 35 as follows:

AAMA 711-07 Voluntary Specification for Self Adhering Flashing Used for Installation of Exterior Wall Fenestration Products

AAMA 714-11 Voluntary Specification for Liquid Applied Flashing Used to Create a Water-Resistive Seal around Exterior Wall Openings in Buildings

Reason: This proposal will add new requirements to the code. Self-adhered membranes and fluid –applied membranes comprise growing segments of the flashing material market, but no material property or performance requirements for these materials are currently included in the code. Industry developed standards, AAMA 711 and AAMA 714, were developed to insure that these types of material meet minimum performance specifications. This proposal incorporates these industry standards by reference into the code. The properties and quality of flashing materials are crucial to successful implementation of the water management in wall systems.

Cost Impact: The code change proposal will not increase the cost of construction.

Analysis: A review of the standard proposed for inclusion in the code, AAMA 711-07 and AAMA 714-11, with regard to the ICC criteria for referenced standards (Section 3.6 of CP#28) will be posted on the ICC website on or before April 2, 2012.

FS161-12

Public Hearing:	Committee:	AS	AM	D
	Assembly:	ASF	AMF	DF

1405.4-FS-WESTON

FS162 – 12

Table 1405.2, 1405.7, 1405.8

Proponent: John Woestman, Kellen Company, representing Masonry Veneer Manufacturers Association (MVMA) (jwoestman@kellencompany.com)

Revise as follows:

**TABLE 1405.2
MINIMUM THICKNESS OF WEATHER COVERINGS**

COVERING TYPE	MINIMUM THICKNESS (inches)
PreCast stone facing ^e	0.625

(Portions of table not shown remain unchanged)

For SI: 1 inch = 25.4 mm.

- a. Wood siding of thicknesses less than 0.5 inch shall be placed over sheathing that conforms to Section 2304.6.
- b. Exclusive of texture.
- c. As measured at the bottom of decorative grooves.
- d. 16 ounces per square foot for cold-rolled copper and lead-coated copper, 12 ounces per square foot for copper shingles, high-yield copper and leadcoated high-yield copper.
- e. Includes scratch coat, setting bed, and precast stone.

1405.7 Stone veneer. Anchored Sstone veneer units not exceeding 10 inches (254 mm) in thickness shall be anchored directly to masonry, concrete or to stud construction by one of the following methods:

(No change to items 1 through 3)

1405.8 Slab-type veneer. Anchored Sslab-type veneer units not exceeding 2 inches (51 mm) in thickness shall be anchored directly to masonry, concrete or stud construction For veneer units of marble, travertine, granite or other stone units of slab form ties of corrosion-resistant dowels in drilled holes shall be located in the middle third of the edge of the units, spaced a maximum of 24 inches (610 mm) apart around the periphery of each unit with not less than four ties per veneer unit. Units shall not exceed 20 square feet (1.9 m²) in area. If the dowels are not tight fitting, the holes shall be drilled not more than 0.063 inch (1.6 mm) larger in diameter than the dowel, with the hole countersunk to a diameter and depth equal to twice the diameter of the dowel in order to provide a tight-fitting key of cement mortar at the dowel locations when the mortar in the joint has set. Veneer ties shall be corrosion-resistant metal capable of resisting, in tension or compression, a force equal to two times the weight of the attached veneer. If made of sheet metal, veneer ties shall be not smaller in area than 0.0336 by 1 inch (0.853 by 25 mm) or, if made of wire, not smaller in diameter than 0.1483-inch (3.76 mm) wire.

Reason: While working on several code change proposals to clarify requirements for adhered masonry veneer, these minor revision opportunities were identified.

The revision of Table 1405.2 is proposed as "Cast stone" is defined in the IBC as precast of Portland cement concrete and used as a trim, veneer, or facing." Precast stone" is not defined in the IBC.

The other revisions provide consistency in language for these types of anchored veneer, and to clarify these are anchored veneer requirements (and not adhered veneer requirements).

Cost Impact: None

FS162-12

Public Hearing:	Committee:	AS	AM	D
	Assembly:	ASF	AMF	DF

T1405.2-FS-WOESTMAN

FS163 – 12

1405.8

Proponent: Bonnie Manley, P.E., American Iron and Steel Institute (bmanley@steel.org)

Revise as follows:

1405.8 Slab-type veneer. Slab-type veneer units not exceeding 2 inches (51 mm) in thickness shall be anchored directly to masonry, concrete or ~~stud-light-frame~~ construction. For veneer units of marble, travertine, granite or other stone units of slab form ties of corrosion-resistant dowels in drilled holes shall be located in the middle third of the edge of the units, spaced a maximum of 24 inches (610 mm) apart around the periphery of each unit with not less than four ties per veneer unit. Units shall not exceed 20 square feet (1.9 m²) in area. If the dowels are not tight fitting, the holes shall be drilled not more than 0.063 inch (1.6 mm) larger in diameter than the dowel, with the hole countersunk to a diameter and depth equal to twice the diameter of the dowel in order to provide a tight-fitting key of cement mortar at the dowel locations when the mortar in the joint has set. Veneer ties shall be corrosion-resistant metal capable of resisting, in tension or compression, a force equal to two times the weight of the attached veneer. If made of sheet metal, veneer ties shall be not smaller in area than 0.0336 by 1 inch (0.853 by 25 mm) or, if made of wire, not smaller in diameter than 0.1483-inch (3.76 mm) wire.

Reason: This minor editorial change corrects terminology to match the defined term found in IBC, Section 202, *Light-Frame Construction*.

Cost Impact: No impact to the cost of construction is anticipated.

FS163-12

Public Hearing:	Committee:	AS	AM	D
	Assembly:	ASF	AMF	DF

1405.8-FS-MANLEY

FS164 – 12

1405.11

Proponent: Bonnie Manley, P.E., American Iron and Steel Institute (bmanley@steel.org)

Revise as follows:

1405.11 Metal veneers. Veneers of metal shall be fabricated from *approved* corrosion-resistant materials or shall be protected front and back with porcelain enamel, or otherwise be treated to render the metal resistant to corrosion. Such veneers shall not be less than 0.0149-inch (0.378 mm) nominal thickness sheet steel mounted on wood or metal furring strips or approved sheathing on ~~the wood light-frame~~ construction.

Reason: In this application, the use of sheathing should not be limited solely to wood construction. Rather, by utilizing the more general term of *light-frame construction*, which is defined in IBC Section 202, it allows approved sheathing to be used on both wood and cold-formed steel framing.

Cost Impact: No impact to the cost of construction is anticipated.

FS164-12

Public Hearing:	Committee:	AS	AM	D
	Assembly:	ASF	AMF	DF

1405.11-FS-MANLEY

FS165 – 12

1405.11.1

Proponent: Bonnie Manley, P.E., American Iron and Steel Institute (bmanley@steel.org)

Revise as follows:

1405.11.1 Attachment. Exterior metal veneer shall be securely attached to the supporting masonry or framing members with corrosion-resistant fastenings, metal ties or by other *approved* devices or methods. The spacing of the fastenings or ties shall not exceed 24 inches (610 mm) either vertically or horizontally, but where units exceed 4 square feet (0.4 m²) in area there shall be not less than four attachments per unit. The metal attachments shall have a cross-sectional area not less than provided by W 1.7 wire. Such attachments and their supports shall be capable of resisting a horizontal force in accordance with designed and constructed to resist the wind loads as specified in Section 1609 for components and cladding, but in no case less than 20 psf (0.958 kg/m²).

Reason: As a result of the publication of the 2010 edition of ASCE 7, the 2012 edition of the IBC made significant changes to the wind load provisions in Section 1609, including the conversion from nominal design wind speeds to ultimate design wind speeds, and the creation of wind speed maps that reflect a structure's particular Risk Category. (See Section 1609.3.) Unfortunately, in this process, this minimum pressure for the attachment of metal veneers in Section 1405.11.1 was not updated. This leaves one of two options available: 1. the minimum wind pressure could be corrected to reflect the ASCE 7-10 basis, if it is still needed; or, 2. the minimum pressure could be eliminated in deference to the minimum design wind pressure specified in ASCE 7.

Rather than continue to complicate the code with a specific minimum pressure that requires continued maintenance, we recommend that it be eliminated and, that the section defer to the ASCE 7 minimum net design wind pressure for components and cladding, which is set at 16 psf in ASCE 7-10, Section 30.2.2. (See also 1609.6.3 for the minimum specified in the simplified method.) ASCE 7-10, Chapter 30 is adopted in Section 1609.

Cost Impact: No impact to the cost of construction is anticipated.

FS165-12

Public Hearing:	Committee:	AS	AM	D
	Assembly:	ASF	AMF	DF

1405.11.1-FS-MANLEY

FS166 – 12

1405.11.3

Proponent: Bonnie Manley, P.E., American Iron and Steel Institute (bmanley@steel.org)

Revise as follows:

1405.11.3 Backup. Masonry backup shall not be required for metal veneer unless required by~~except as is necessary to meet~~ the fire resistance requirements of this code.

Reason: This editorial modification simplifies the code language.

Cost Impact: No impact to the cost of construction is anticipated.

FS166-12

Public Hearing:	Committee:	AS	AM	D
	Assembly:	ASF	AMF	DF

1405.11.3-FS-MANLEY

FS167 – 12

1405.14.1

Proponent: Bonnie Manley, P.E., American Iron and Steel Institute (bmanley@steel.org)

Revise as follows:

1405.14.1 Application. The siding shall be applied over sheathing or materials listed in Section 2304.6. Siding shall be applied to conform with the *water-resistive barrier* requirements in Section 1403. Siding and accessories shall be installed in accordance with *approved* manufacturer's instructions. Unless otherwise specified in the *approved* manufacturer's instructions, nails used to fasten the siding and accessories shall have a minimum 0.313-inch (7.9 mm) head diameter and 1/8-inch (3.18 mm) shank diameter. The nails shall be corrosion resistant and shall be long enough to penetrate the studs or nailing strip at least 3/4 inch (19 mm). For cold-formed steel light-frame construction, corrosion-resistant fasteners shall be used and shall penetrate the cold-formed steel framing at least three exposed threads. Where the siding is installed horizontally, the fastener spacing shall not exceed 16 inches (406 mm) horizontally and 12 inches (305 mm) vertically. Where the siding is installed vertically, the fastener spacing shall not exceed 12 inches (305 mm) horizontally and 12 inches (305 mm) vertically.

Reason: The section should include guidance on fastener requirements for cold-formed steel light-frame construction similar to those specified in IBC Section 1405.16. In adding the language from Section 1405.16, a change was made from "all weather screws" to "corrosion-resistant fasteners," which is the more appropriate and more commonly used term. Additionally, the language was corrected from "three full threads" to "three exposed threads." This matches language used in AISI S200, Section D1.3. Also, it avoids confusion on what a "full thread" is; as long as three threads can be seen from any side of the screw, it's sufficient. A separate, coordinating proposal for Section 1405.16 corrects the language there.

Cost Impact: No impact to the cost of construction is anticipated.

FS167-12

Public Hearing:	Committee:	AS	AM	D
	Assembly:	ASF	AMF	DF

1405.14.1-FS-MANLEY

FS168 – 12

1405.14.1, 1405.14.2 (New), 1405.14.2.1 (New), 1405.14.2.2 (New), 1405.14.2.3 (New)

Proponent: Jay Crandell, ARES Consulting, representing the Foam Sheathing Committee of the American Chemistry Council- Plastics Division (jcrandell@aresconsulting.biz); Matt Dobson, Vinyl Siding Institute (mdobson@vinylsiding.org)

THIS CODE CHANGE WILL BE HEARD BY THE IBC STRUCTURAL COMMITTEE. SEE THE TENTATIVE HEARING ORDER FOR THIS COMMITTEE.

Revise as follows:

1405.14.1 Application. The siding shall be applied over sheathing or materials listed in Section 2304.6. Vinyl siding installed over foam plastic sheathing shall comply with Section 1405.14.2. Siding shall be applied to conform with the *water-resistive barrier* requirements in Section 1403. Siding and accessories shall be installed in accordance with *approved* manufacturer's instructions. Unless otherwise specified in the *approved* manufacturer's instructions, nails used to fasten the siding and accessories shall have a minimum 0.313-inch (7.9 mm) head diameter and 1/8-inch (3.18 mm) shank diameter. The nails shall be corrosion resistant and shall be long enough to penetrate the studs or nailing strip at least 3/4 inch (19 mm). Where the siding is installed horizontally, the fastener spacing shall not exceed 16 inches (406 mm) horizontally and 12 inches (305 mm) vertically. Where the siding is installed vertically, the fastener spacing shall not exceed 12 inches (305 mm) horizontally and 12 inches (305 mm) vertically.

1405.14.2 Foam Plastic Sheathing. Vinyl siding used with foam plastic sheathing shall be installed in accordance with Section 1405.14.2.1, 1405.14.2.2, or 1405.14.2.3.

Exceptions:

1. Where the foam plastic sheathing is applied directly over wood structural panels, fiberboard, gypsum sheathing, or other *approved* backing capable of independently resisting the design wind pressure, the requirements of Section 1405.14.1 shall apply.
2. Where the foam plastic sheathing is capable of independently resisting the design wind pressure, including its connections to the wall structure, the requirements of Section 1405.14.1 shall apply.

1405.14.2.1 Basic wind speed not exceeding 90 miles per hour (V_{asd}) and Exposure Category B. Where the basic wind speed does not exceed 90 miles per hour (40 m/s) (V_{asd}), the Exposure Category is B and gypsum wall board or equivalent is installed on the side of the wall opposite the foam plastic sheathing, the minimum siding fastener penetration into wood framing shall be 1 1/4 inches (32 mm) using minimum 0.120-inch diameter nail (shank) with a minimum 0.313-inch diameter head, 16 inches on center. The foam plastic sheathing shall be minimum 1/2-inch-thick (12.7 mm) (nominal) extruded polystyrene per ASTM C 578, 1/2-inch-thick (12.7 mm) (nominal) polyisocyanurate per ASTM C 1289, or 1-inch-thick (25 mm) (nominal) expanded polystyrene per ASTM C 578.

1405.14.2.2 Basic wind speed exceeding 90 miles per hour (V_{asd}) or Exposure Categories C and D. Where the basic wind speed exceeds 90 miles per hour (40 m/s) (V_{asd}) or the Exposure Category is C or D, or all conditions of Section 1405.14.2.1 are not met, the design pressure rating for the assembly shall meet or exceed the components and cladding wind load determine in accordance with Section 1609. The design wind pressure rating of the vinyl siding for installation over backing capable of independently resisting the design wind pressure as provided in the vinyl siding manufacturer's product specifications shall be adjusted for the following wall assembly conditions:

1. For wall assemblies with foam plastic sheathing on the exterior side and gypsum wall board or equivalent on the interior side of the wall, the vinyl siding's design wind pressure rating shall be multiplied by 0.39.

2. For wall assemblies with foam plastic sheathing on the exterior side and no gypsum wall board or equivalent on the interior side of wall, the vinyl siding's design wind pressure rating shall be multiplied by 0.27.

1405.14.2.3 Manufacturer specification. Where the vinyl siding manufacturer's product specifications provide an *approved* design wind pressure rating for installation over foam plastic sheathing, use of this design wind pressure rating shall be permitted and the siding shall be installed in accordance with the manufacturer's installation instructions.

Reason: Vinyl siding is commonly installed over foam plastic insulation (sheathing) for energy code compliance. Provisions are needed to ensure appropriate installation of vinyl siding over foam sheathing to resist wind load. These provisions are consistent with provisions included in the 2009 and 2012 IRC. The provisions are based on testing of various foam sheathing materials and vinyl siding materials with a range of wind pressure ratings to ensure broad applicability and adequate performance. A summary of the research and testing can be found at www.foamsheathing.org, including accredited test laboratory test reports. Additional confirmatory testing is on-going at the IBHS full-scale wind tunnel with initial results supporting the proposed adjustment of vinyl siding wind pressure ratings. The adjustments to vinyl siding wind pressure ratings for use of foam sheathing include an increase in safety factor from 1.5 to 2.0 as well as an increase in the net wind load acting on the vinyl siding to account for the combined wind pressure acting across the foam sheathing and vinyl siding layers of the wall. These provisions will ensure compliance with wind load provisions in Section 1609 of the IBC as applicable to exterior walls in Chapter 14 of the IBC.

Cost Impact: The code change proposal will not increase the cost of construction.

FS168-12

Public Hearing:	Committee:	AS	AM	D
	Assembly:	ASF	AMF	DF

1405.14.1-FS-CRANDELL

FS169 – 12

1405.16

Proponent: Bonnie Manley, P.E., American Iron and Steel Institute (bmanley@steel.org)

Revise as follows:

1405.16 Fiber-cement siding. Fiber-cement siding complying with Section 1404.10 shall be permitted on exterior walls of Type I, II, III, IV and V construction for wind pressure resistance or wind speed exposures as indicated by the manufacturer's listing and *label* and *approved* installation instructions. Where specified, the siding shall be installed over sheathing or materials *listed* in Section 2304.6 and shall be installed to conform to the *water-resistive barrier* requirements in Section 1403. Siding and accessories shall be installed in accordance with *approved* manufacturer's instructions. Unless otherwise specified in the *approved* manufacturer's instructions, nails used to fasten the siding to wood studs shall be corrosion-resistant round head smooth shank and shall be long enough to penetrate the studs at least 1 inch (25 mm). For cold-formed steel light-frame construction metal framing, ~~all-weather screws~~ corrosion-resistant fasteners shall be used and shall penetrate the the cold-formed steel framing-metal framing at least three exposed full threads.

Reason: The editorial modifications correct the terminology to reflect what is adopted in Section 2211. A change was made from "all weather screws" to "corrosion-resistant fasteners," which is the more appropriate and more commonly used term. Additionally, the language was corrected from "three full threads" to "three exposed threads." This matches language used in AISI S200, Section D1.3. Also, it avoids confusion on what a "full thread" is; as long as three threads can be seen from any side of the screw, it's sufficient.

Cost Impact: No impact to the cost of construction is anticipated.

FS169-12

Public Hearing:	Committee:	AS	AM	D
	Assembly:	ASF	AMF	DF

1405.16-FS-MANLEY

FS170 – 12

1405.16.1, Chapter 35

Proponent: John Mulder, Intertek Testing Services NA, Inc., representing International Standards Organization Technical Committee 77, Products in Fibre-reinforced Cement and self

Revise as follows:

1405.16.1 Panel siding. Fiber-cement panels shall comply with the requirements of ASTM C1186, Type A, minimum Grade II (or ISO 8336, Category A, minimum Class 2). Panels shall be installed with the long dimension either parallel or perpendicular to framing. Vertical and horizontal joints shall occur over framing members and shall be ~~sealed~~ protected with approved caulking, or covered with battens, or flashing, or be vertical or horizontal shiplap, or otherwise shall be designed to comply with Section 1403.2. Panel siding shall be installed with fasteners in accordance with the *approved* manufacturer's instructions.

Add new standard to Chapter 35 as follows:

ISO
8336-2009 Fiber-Cement Flat Sheets – Product Specification and Test Methods

Reason: Performance requirements of ISO 8336, *Fibre-cement flat sheets – Product specification and test methods*, have been harmonized with the performance requirements of ASTM C1186, *Standard Specification for Flat Non-Asbestos Fiber-Cement Sheets*. Fiber-cement siding producers in Mexico, Central and South America, Europe, Asia, Australia and New Zealand currently manufacture and test their fiber-cement siding products for compliance with ISO 8336. The inclusion of this Standard reference in the IBC will permit manufacturers worldwide to demonstrate product compliance to IBC requirements. The addition of a reference to ISO 8336 in the Code removes a barrier to trade. Additional editorial changes are proposed to clarify the nature of the required vertical and/or horizontal joint protection to include reference to *approved* caulking and the recognition of both vertical or horizontal shiplap joints as a means of protecting the joints as is also common with wood panel siding.

Cost Impact: The code change proposal will not increase the cost of construction because the product is already recognized for use in the Code. Reference to compliance with this alternative standard, an International Standard requiring the same performance as the ASTM Standard, will reduce barriers to trade by allowing foreign products complying with ISO 8336, Category A, minimum Class 2, market access to the United States without the need for additional product compliance documentation.

Analysis: A review of the standard proposed for inclusion in the code, ISO 8336-2009, with regard to the ICC criteria for referenced standards (Section 3.6 of CP#28) will be posted on the ICC website on or before April 2, 2012.

FS170-12

Public Hearing:	Committee:	AS	AM	D
	Assembly:	ASF	AMF	DF

1405.16.1-FS-MULDER

FS171 – 12

1405.16.2, Chapter 35

Proponent: John Mulder, Intertek Testing Services NA, Inc., representing International Standards Organization Technical Committee 77, Products in Fibre-reinforced Cement and self

Revise as follows:

1405.16.2 Lap siding. Fiber-cement lap siding having a maximum width of 12 inches (305 mm) shall comply with the requirements of ASTM C1186, Type A, minimum Grade II (or ISO 8336, Category A, minimum Class 2). Lap siding shall be lapped a minimum 1¼ inches (32 mm) and lap siding not having tongue-and-groove end joints shall have the ends sealed with approved caulking, or covered with an H-section joint cover, or located over a strip of flashing or otherwise shall be designed to comply with Section 1403.2. Lap siding courses shall be installed with fastener heads exposed or concealed in accordance with the *approved* manufacturer's instructions.

Add new standard to Chapter 35 as follows:

ISO
8336-2009 Fiber-Cement Flat Sheets – Product Specification and Test Methods

Reason: Performance requirements of ISO 8336, *Fibre-cement flat sheets – Product specification and test methods*, have been harmonized with the performance requirements of ASTM C1186, *Standard Specification for Flat Non-Asbestos Fiber-Cement Sheets*. Fiber-cement siding producers in Mexico, Central and South America, Europe, Asia, Australia and New Zealand currently manufacture and test their fiber-cement siding products for compliance with ISO 8336. The inclusion of this Standard reference in the IBC will permit manufacturers worldwide to demonstrate product compliance to IBC requirements. The addition of a reference to ISO 8336 in the Code removes a barrier to trade. Additional editorial changes are proposed to clarify the nature of the required vertical joint protection and to include reference to *approved* caulking.

Cost Impact: The code change proposal will not increase the cost of construction because the product is already recognized for use in the Code. Reference to compliance with this alternative standard, an International Standard requiring the same performance as the ASTM Standard, will reduce barriers to trade by allowing foreign products complying with ISO 8336, Category A, minimum Class 2, market access to the United States without the need for additional product compliance documentation.

Analysis: A review of the standard proposed for inclusion in the code, ISO 8336-2009, with regard to the ICC criteria for referenced standards (Section 3.6 of CP#28) will be posted on the ICC website on or before April 2, 2012.

FS171-12

Public Hearing:	Committee:	AS	AM	D
	Assembly:	ASF	AMF	DF

1405.16.2-FS-MULDER

FS172 – 12

1406.2.1.1, 2603.5.7

Proponent: Michael D. Fischer, Kellen Company, representing self (mfischer@kellencompany.com)

Revise as follows:

1406.2.1.1 Ignition resistance. Where permitted by Section 1406.2.1, combustible exterior wall coverings shall be tested in accordance with NFPA 268.

Exceptions:

1. Wood or wood-based products.
2. Other combustible materials covered with an exterior weather covering, other than vinyl sidings, ~~listed included in and complying with the thickness requirements of in~~ Table 1405.2.
3. Aluminum having a minimum thickness of 0.019 inch (0.48 mm).

Revise as follows:

2603.5.7 Ignition. *Exterior walls* shall not exhibit sustained flaming where tested in accordance with NFPA 268. Where a material is intended to be installed in more than one thickness, tests of the minimum and maximum thickness intended for use shall be performed.

Exception: Assemblies protected on the outside with one of the following:

1. A thermal barrier complying with Section 2603.4.
2. A minimum 1 inch (25 mm) thickness of concrete or masonry.
3. Glass-fiber-reinforced concrete panels of a minimum thickness of 3/8 inch (9.5 mm).
4. Metal-faced panels having minimum 0.019-inch thick (0.48 mm) aluminum or 0.016-inch-thick (0.41 mm) corrosion-resistant steel outer facings.
5. A minimum 7/8-inch (22.2 mm) thickness of stucco complying with Section 2510.
6. Exterior weather coverings, other than vinyl sidings, meeting the minimum thickness requirements of Table 1405.2.

Reason: This proposal does two things: first, it clarifies that the exception for exterior weather coverings in 1406.2.1.1 must meet the minimum thickness requirements of Table 1405.2, and second it closes a gap in the code between 1406.2.1.1 and 2603.5.7. NFPA 268 is not required for certain combustible exterior wall coverings per 1406.2.1.1; the proposal makes that clear in 2603.5.7 in order to add consistency and clarity to the intended application of NFPA 268.

Cost Impact: The proposal will not increase the cost of construction.

FS172-12

Public Hearing:	Committee:	AS	AM	D
	Assembly:	ASF	AMF	DF

1406.2.1.1-FS-FISCHER

FS173 – 12

1407.1.1

Proponent: Jesse J. Beitel, Hughes Associates, Inc., representing Centria (jbeitel@haifire.com)

Revise as follows:

1407.1 General. The provisions of this section shall govern the materials, construction and quality of metal composite materials (MCM) for use as *exterior wall coverings* in addition to other applicable requirements of Chapters 14 and 16.

1407.1.1 ~~Core Material Plastic core.~~ MCMs that contain a core material of foam plastic insulation as defined in Section 2602.1 shall comply with the requirements of Chapter 26.

~~The plastic core of the MCM shall not contain foam plastic insulation as defined in Section 2602.1.~~

Reason: MCMs contain a solid plastic core and are regulated by Section 1407. A factory-manufactured panel consisting of steel skins and a foam plastic insulation core is regulated by Chapter 26. However, some Code officials and others have interpreted the existing Section 1407.1.1 such that the factory-manufactured panel consisting of steel skins and foam plastic insulation core is not allowed by the Code and thus cannot be used.

The proposed wording clarifies the intent of the Code and will hopefully avoid future misinterpretations.

Cost Impact: The Code change proposal will not increase the cost of construction.

FS173-12

Public Hearing: Committee:	AS	AM	D
Assembly:	ASF	AMF	DF

1407.1.1-FS-BEITEL

FS174 – 12

1407.10.2

Proponent: Marcelo M Hirschler, GBH International (gbhint@aol.com)

Revise as follows:

1407.10.2 Thermal barriers. MCM shall be separated from the interior of a building by an approved thermal barrier consisting of 1/2 -inch (12.7 mm) gypsum wallboard or a material that is tested in accordance with and meets the acceptance criteria of both the Temperature Transmission Fire Test and the Integrity Fire Test of NFPA 275. If the integrity fire test is conducted in accordance with NFPA 286, the acceptance criteria shall be as indicated in section 803.1.2 of this code.

Reason: There has been some discussion about allowing as thermal barriers materials that cause flashover when tested to NFPA 286. That should not be allowed and this language will ensure that thermal barriers protect against flashover in the fire area.

Note that the integrity fire test of NFPA 275 can be conducted in accordance with NFPA 286, UL 1040, UL 1715 or FM 4880. In UL 1040, UL 1715 and FM 4880 pass/fail criteria are included and flashover is not permitted. NFPA 286 does not contain pass/fail criteria and the code must have its own acceptance criteria.

Cost Impact: None

FS174-12

Public Hearing:	Committee:	AS	AM	D
	Assembly:	ASF	AMF	DF

1407.10.2-FS-HIRSCHLER

FS175 – 12

1409.10.2

Proponent: Marcelo M Hirschler, GBH International (gbhint@aol.com)

Revise as follows:

1409.10.2 Thermal barriers. HPL shall be separated from the interior of a building by an approved thermal barrier consisting of 1/2-inch (12.7 mm) gypsum wallboard or a material that is tested in accordance with and meets the acceptance criteria of both the Temperature Transmission Fire Test and the Integrity Fire Test of NFPA 275. If the integrity fire test is conducted in accordance with NFPA 286, the acceptance criteria shall be as indicated in section 803.1.2 of this code. ~~equivalent thermal barrier material that will limit the average temperature rise of the unexposed surface to not more than 250°F (121°C) after 15 minutes of fire exposure in accordance with the standard time temperature curve of ASTM E 119 or UL 263. The thermal barrier shall be installed in such a manner that it will remain in place for not less than 15 minutes based on a test conducted in accordance with UL 1715.~~

Reason: This section describes the criteria for a thermal barrier for HPL materials (as contained for MCM materials in 1407.10.2 and for foam plastics in 2603.4) and the language should be similar to the language in those sections. An additional sentence is recommended, as also proposed for section 1407.10.2 and 2603.4) to prevent the use of a thermal barrier that permits flashover.

There has been some discussion about allowing as thermal barriers materials that cause flashover when tested to NFPA 286. That should not be allowed and this language will ensure that thermal barriers protect against flashover in the fire area.

Note that the integrity fire test of NFPA 275 can be conducted in accordance with NFPA 286, UL 1040, UL 1715 or FM 4880. In UL 1040, UL 1715 and FM 4880 pass/fail criteria are included and flashover is not permitted. NFPA 286 does not contain pass/fail criteria and the code must have its own acceptance criteria.

The language in 1407.10.2 and 2603.4 (with the proposed addition) is shown below.

1407.10.2 Thermal barriers. MCM shall be separated from the interior of a building by an approved thermal barrier consisting of 1/2-inch (12.7 mm) gypsum wallboard or a material that is tested in accordance with and meets the acceptance criteria of both the Temperature Transmission Fire Test and the Integrity Fire Test of NFPA 275. If the integrity fire test is conducted in accordance with NFPA 286, the acceptance criteria shall be as indicated in section 803.1.2 of this code.

2603.4 Thermal barrier. Except as provided for in Sections 2603.4.1 and 2603.10, foam plastic shall be separated from the interior of a building by an approved thermal barrier of 1/2-inch (12.7 mm) gypsum wallboard or a material that is tested in accordance with and meets the acceptance criteria of both the Temperature Transmission Fire Test and the Integrity Fire Test of NFPA 275. If the integrity fire test is conducted in accordance with NFPA 286, the acceptance criteria shall be as indicated in section 803.1.2 of this code. Combustible concealed spaces shall comply with Section 718.

Cost Impact: None

FS175-12

Public Hearing:	Committee:	AS	AM	D
	Assembly:	ASF	AMF	DF

1409.10.2-FS-HIRSCHLER

FS176 – 12

1409.11.3 (New), 1409.11.4 (New)

Proponent: Jesse J. Beitel, Hughes Associates, Inc., representing Trespa North America, Ltd
(jbeitel@haifire.com)

Add new text as follows:

1409.11.3 Installations up to 75 feet in height (Option 1). HPL shall not be installed more than 75 feet (22 860 mm) in height above grade plane where installed in accordance with Sections 1409.11.3.1 through 1409.11.3.5.

Exception: Buildings equipped throughout with an automatic sprinkler system in accordance with Section 903.3.1.1 shall be exempt from the height limitation.

1409.11.3.1 Prohibited occupancies. HPL shall not be permitted on buildings classified as Group A-1, A-2, H, I-2 or I-3 occupancies.

1409.11.3.2 Nonfire-resistance-rated exterior walls. HPL shall not be permitted on exterior walls required to have a *fire-resistance rating* by other provisions of this code.

1409.11.3.3 Specifications. HPL shall be required to comply with all of the following:

1. HPL shall have a self-ignition temperature of 650°F (343°C) or greater when tested in accordance with ASTM D 1929.
2. HPL shall conform to one of the following combustibility classifications when tested in accordance with ASTM D 635:

Class CC1: Materials that have a burning extent of 1 inch (25 mm) or less when tested at a nominal thickness of 0.060 inch (1.5 mm) or in the thickness intended for use.

Class CC2: Materials that have a burning rate of 2½ inches per minute (1.06 mm/s) or less when tested at a nominal thickness of 0.060 inch (1.5 mm) or in the thickness intended for use.

1409.11.3.4 Area limitation and separation. The maximum area of a single HPL panel and the minimum vertical and horizontal separation requirements for HPL panels shall be as provided for in Table 1409.11.3.4. The maximum percentage of exterior wall area of any story covered with HPL panels shall not exceed that indicated in Table 1409.11.3.4 or the percentage of unprotected openings permitted by Section 705.8, whichever is smaller.

Exception: In buildings provided with flame barriers complying with Section 705.8.5 and extending 30 inches (760 mm) beyond the exterior wall in the plane of the floor, a vertical separation shall not be required at the floor other than that provided by the vertical thickness of the flame barrier.

1409.11.3.5 Automatic sprinkler system increases. Where the building is equipped throughout with an automatic sprinkler system in accordance with Section 903.3.1.1, the maximum percentage area of exterior wall of any story covered with HPL panels and the maximum square footage of a single area of HPL panels in Table 1409.11.3.4 shall be increased 100 percent. The area of HPL panels shall not exceed 50 percent of the exterior wall area of any story or the area permitted by Section 704.8 for unprotected openings, whichever is smaller.

1409.11.4 Installations up to 75 feet in height (Option 2). HPL shall not be installed more than 75 feet (22 860 mm) in height above grade plane where installed in accordance with Sections 1409.11.4.1 through 1409.11.4.4.

Exception: Buildings equipped throughout with an automatic sprinkler system in accordance with Section 903.3.1.1 shall be exempt from the height limitation.

1409.11.4.1 Minimum fire separation distance. HPL shall not be installed on any wall with a fire separation distance less than 30 feet (9 144 mm).

Exception: Where the building is equipped throughout with an *automatic sprinkler system* in accordance with Section 903.3.1.1, the fire separation distance shall be permitted to be reduced to not less than 20 feet (6096 mm).

1409.11.4.2 Specifications. HPL shall be required to comply with all of the following:

1. HPL shall have a self-ignition temperature of 650°F (343°C) or greater when tested in accordance with ASTM D 1929.
2. HPL shall conform to one of the following combustibility classifications when tested in accordance with ASTM D 635:

Class CC1: Materials that have a burning extent of 1 inch (25 mm) or less when tested at a nominal thickness of 0.060 inch (1.5 mm), or in the thickness intended for use.

Class CC2: Materials that have a burning rate of 2 ½ inches per minute (1.06 mm/s) or less when tested at a nominal thickness of 0.060 inch (1.5 mm), or in the thickness intended for use.

1409.11.4.3 Area and size limitations. The aggregate area of HPL panels shall not exceed 25 percent of the area of any exterior wall face of the story on which it is installed. The area of a single HPL panel installed above the first story above grade plane shall not exceed 16 square feet (1.5 m²) and the vertical dimension of a single HPL panel shall not exceed 4 feet (1219 mm).

Exception: Where the building is equipped throughout with an *automatic sprinkler system* in accordance with Section 903.3.1.1, the maximum aggregate area of HPL panels shall be increased to 50 percent of the exterior wall face of the story on which it is installed and there shall not be a limit on the maximum dimension or area of a single HPL panel.

1409.11.4.4 Vertical separations. Flame barriers complying with Section 705.8 and extending 30 inches (762 mm) beyond the exterior wall or a vertical separation of not less than 4 feet (1219 mm) in height shall be provided to separate HPL panels located on the exterior walls at one story intervals.

Exception: Buildings equipped throughout with an *automatic sprinkler system* in accordance with Section 903.3.1.1.

**TABLE 1409.11.3.4
AREA LIMITATION AND SEPARATION REQUIREMENTS FOR HPL PANELS**

Fire Separation Distance (feet)	Combustibility Class of HPL	Maximum Percentage Area of Exterior Wall Covered with HPL Panels	Maximum Single Area of HPL Panels (square feet)	Minimum Separation of HPL Panels (feet)	
				Vertical	Horizontal
Less than 6	—	Not Permitted	Not Permitted	—	—
6 or more but less than 11	CC1	10	50	8	4
	CC2	Not Permitted	Not Permitted	—	—
11 or more but less than or equal to 30	CC1	25	90	6	4
	CC2	15	70	8	4
More than 30	CC1	50	Not Permitted	3 ^a	0
	CC2	50	100	6 ^a	3

For SI: 1 foot; 304.8 mm, 1 square foot; 0.0929 m².

a. For reductions in the minimum vertical separation, see Section 1409.11.3.4.

Reason: This code change proposal provides for additional alternate conditions under which HPL and HPL systems can be installed on buildings greater than 50 feet in height. Two conditions are allowed which are based on the allowable use of light-transmitting plastics in the exterior walls of buildings in accordance with Section 2607 Light-transmitting Plastic Wall Panels, Section 2608 Light-transmitting Plastic Glazing and Section 1407.11.3 for MCMs.

The two Chapter 26 sections have been in the International Building Code (IBC) since its inception and were basically contained in all three of the legacy model building codes for many years prior to the development of the IBC. The MCM section was added during the last Code cycle. Thus, the concept of limited amounts of these types of materials on exterior walls has a long history of successful fire performance under the previous legacy codes, as well as under the IBC.

We believe that if exposed light-transmitting plastics and MCMs can be used on the exterior walls of buildings under the provisions indicated in those sections, it is reasonable to expect that HPLs should perform as well or better. It should be noted that the HPL meet all the requirements necessary to be an approved plastic which is also the requirement for light-transmitting plastics. Additionally, in a manner similar to MCMs the HPLs must meet an even more stringent burning limitation than light-transmitting plastics since HPLs are required to be tested in accordance with ASTM E84 or UL 723 to demonstrate a flame spread index not greater than 75 and a smoke-developed index not greater than 450.

Based on this, we request the Committee approve this code change proposal to allow for additional but limited applications of HPLs on buildings greater than 50 feet in height.

Cost Impact: This code change proposal will not increase the cost of construction.

FS176-12

Public Hearing:	Committee:	AS	AM	D
	Assembly:	ASF	AMF	DF

1409.11.3 (NEW)-FS-BEITEL

FS177 – 12

809 (New), 1410 (New), 2103.15 (New)

Proponent: John Woestman, Kellen Company, representing Masonry Veneer Manufacturers Association (MVMA) (jwoestman@kellencompany.com)

Add new text as follows:

SECTION 809 **INTERIOR ADHERED MASONRY VENEER**

809.1 Adhered masonry veneer. Interior adhered masonry veneer shall comply with the applicable requirements in Section 809 and Sections 6.1 and 6.3 of TMS 402/ACI 530/ASCE 5.

809.2 Interior adhered masonry veneers. Interior adhered masonry veneers shall have a maximum weight of 20 psf (0.958 kg/m²) and shall be installed in accordance with Section 809 and the requirements of Section 1410 applicable to interior adhered masonry veneer. Where the interior adhered masonry veneer is supported by wood construction, the supporting members shall be designed to limit vertical deflection to L/600 of the span of the supporting members.

Revise as follows:

~~**1405.10 Adhered masonry veneer.** Adhered masonry veneer shall comply with the applicable requirements in Section 1405.10 and Sections 6.1 and 6.3 of TMS 402/ACI 530/ASCE 5.~~

~~**1405.10.1 Exterior adhered masonry veneer.** Exterior adhered masonry veneer shall be installed in accordance with Section 1405.10 and in accordance with the manufacturer's instructions.~~

~~**1405.10.1.1 Water resistive barriers.** Water resistive barriers shall be installed as required in Section 2510.6.~~

~~**1405.10.1.2 Flashing at foundation.** A corrosion resistant screed or flashing of a minimum 0.019 inch (0.48 mm) or 26 gauge galvanized or plastic with a minimum vertical attachment flange of 3 1/2 inches (89 mm) shall be installed extend a minimum of 1 inch (25 mm) below the foundation plate line on exterior stud walls in accordance with Section 1405.4. The water resistive barrier shall lap over the exterior of the attachment flange of the screed or flashing.~~

~~**1405.10.1.3 Clearances.** On exterior stud walls, adhered masonry veneer shall be installed a minimum of 4 inches (102 mm) above the earth, or a minimum of 2 inches (51 mm) above paved areas, or a minimum of 1/2 inch (12 mm) above exterior walking surfaces which are supported by the same foundation that supports the exterior wall.~~

~~**1405.10.2 Exterior adhered masonry veneers—porcelain tile.** Adhered units shall not exceed 5/8 inch (15.8 mm) thickness and a maximum of 24 inches (610 mm) in any face dimension nor more than 3 square feet (0.28 m²) in total face area and shall not weigh more than 9 pounds psf (0.43 kN/m²). Porcelain tile shall be adhered to an approved backing system.~~

~~**1405.10.3 Interior adhered masonry veneers.** Interior adhered masonry veneers shall have a maximum weight of 20 psf (0.958 kg/m²) and shall be installed in accordance with Section 1405.10. Where the interior adhered masonry veneer is supported by wood construction, the supporting members shall be designed to limit deflection to L/600 of the span of the supporting members.~~

SECTION 1410
EXTERIOR ADHERED MASONRY VENEER

1410.1 General. The provisions of this section shall govern the materials, construction, and quality of adhered masonry veneer for use as exterior wall coverings in addition to the applicable requirements of Chapters 14, 16, 21, and 25. Interior adhered masonry veneer shall comply with Section 809.

1410.2 Exterior adhered masonry veneer. Exterior adhered masonry veneer shall be installed in accordance with Section 1410 and in accordance with the manufacturer's instructions and shall comply with the applicable requirements in Sections 6.1 and 6.3 of TMS 402/ACI 530/ASCE 5..

1410.2.1 Flashing. Flashing shall comply with the applicable requirements of Section 1405.4 and the following.

1410.2.1.1 Flashing at foundation. A corrosion resistant screed or flashing of a minimum 0.019-inch (0.48 mm) or 26 gauge galvanized or plastic with a minimum vertical attachment flange of 3/2 inches (89 mm) shall be installed extend a minimum of 1 inch (25 mm) below the foundation plate line on exterior stud walls in accordance with Section 1405.4. The water-resistive barrier shall lap over the exterior of the attachment flange of the screed or flashing.

1410.2.2 Water-resistive barriers. Water-resistive barriers shall be installed as required in Section 2510.6.

1410.2.3 Clearances. On exterior stud walls, adhered masonry veneer shall be installed a minimum of 4 inches (102 mm) above the earth, or a minimum of 2 inches (51 mm) above paved areas, or a minimum of 1/2 inch (12 mm) above exterior walking surfaces which are supported by the same foundation that supports the exterior wall.

1410.2.4 Adhered masonry veneer installed with lath and mortar. Exterior adhered masonry veneer installed with lath and mortar shall comply with the following.

1410.2.4.1 Lathing. Lathing shall comply with the requirements of Section 2510.

1410.2.4.2 Scratch Coat. A nominal 1/2" thick layer of mortar complying with the material requirements of Sections 2103.15 and 2512.2 shall be applied encapsulating the lathing. The surface of this mortar shall be scored horizontally resulting in a scratch coat.

1410.2.4.3 Adhering veneer. The masonry veneer units shall be adhered to the mortar scratch coat with a nominal 1/2" thick setting bed of mortar complying with Sections 2103.15 and 2512.2 applied to create a full setting bed for the back of the masonry veneer units. The masonry veneer units shall be worked into the setting bed resulting in a nominal 3/8" setting bed after the masonry veneer units are applied.

1410.2.5 Adhered masonry veneer applied directly to masonry and concrete. Adhered masonry veneer applied directly to masonry or concrete shall comply with the applicable requirements of Section 1410 and with the requirements of Section 2510.7 or Section 1410.2.4.

1410.2.6 Cold weather construction. Cold weather construction of adhered masonry veneer shall comply with the requirements of Sections 2104.3 and 2512.4.

1410.2.7 Hot weather construction. Hot weather construction of adhered masonry veneer shall comply with the requirements of Section 2104.4.

1410.3 Exterior adhered masonry veneers—porcelain tile. Adhered units shall not exceed 5/8 inch (15.8 mm) thickness and a maximum of 24 inches (610 mm) in any face dimension nor more than 3 square feet (0.28 m²) in total face area and shall not weigh more than 9 pounds psf (0.43 kN/m²). Porcelain tile shall be adhered to an approved backing system.

Add new text as follows:

2103.15 Mortar for adhered masonry veneer. Mortar for use with adhered masonry veneer shall conform to ASTM C270 for Type N or Type S, or shall comply with ANSI A118.4 for latex-modified Portland cement mortar.

Reason: This proposal seeks to clarify requirements for adhered masonry veneer (AMV).

This proposal moves the requirements for exterior AMV to a new section at the end of Chapter 14, Exterior Walls, and then expands on the requirements for exterior AMV. The requirements for interior AMV are moved to a new section at the end of Chapter 8, Interior Finishes (as AMV installed in the interior is essentially an interior finish).

For ease of presenting the new sections at the ends of Chapter 8 and Chapter 14, the original text in Section 1405.10 is shown as deleted. However, the current technical requirements of the IBC in 1405.10 are included in the two new sections for interior AMV (proposed Section 809) and exterior AMV (proposed Section 1410)

AMV is similar in some ways to masonry, and also similar in some ways to cement plaster. But AMV is also dissimilar to both of these well-known materials. With this proposal, we have attempted to reference existing code requirements where appropriate. Also, where we believe appropriate, we have presented specific requirements for AMV.

Regarding the mortar used for AMV systems, we're proposing a new section at the end of Section 2103 clearly defining the requirements for mortars used with AMV.

Cost Impact: None

FS177-12

Public Hearing:	Committee:	AS	AM	D
	Assembly:	ASF	AMF	DF

809 (NEW)-FS-WOESTMAN

FS178 – 12

2603.1

Proponent: Philip J. Smith PE, representing FM Approvals (phillip.smith@fmapprovals.com)

Revise as follows:

2603.3 Surface-burning characteristics. Unless otherwise indicated in this section, foam plastic insulation and foam plastic cores of manufactured assemblies shall have a flame spread index of not more than 75 and a smoke-developed index of not more than 450 where tested in the maximum thickness intended for use in accordance with ASTM E 84 or UL 723. Loose fill-type foam plastic insulation shall be tested as board stock for the flame spread and smoke-developed indexes.

Exceptions:

1. Smoke-developed index for interior *trim* as provided for in Section 2604.2.
2. In cold storage buildings, ice plants, food plants, food processing rooms and similar areas, foam plastic insulation where tested in a thickness of 4 inches (102 mm) shall be permitted in a thickness up to 10 inches (254 mm) where the building is equipped throughout with an automatic fire sprinkler system in accordance with Section 903.3.1.1. The approved *automatic sprinkler system* shall be provided in both the room and that part of the building in which the room is located.
3. Foam plastic insulation that is a part of a Class A, B or C roof-covering assembly provided the assembly with the foam plastic insulation satisfactorily passes ~~FM 4450~~ NFPA 276 or UL 1256. The smoke-developed index shall not be limited for roof applications.
4. Foam plastic insulation greater than 4 inches (102 mm) in thickness shall have a maximum flame spread index of 75 and a smoke-developed index of 450 where tested at a minimum thickness of 4 inches (102 mm), provided the end use is approved in accordance with Section 2603.10 using the thickness and density intended for use.
5. Flame spread and smoke-developed indexes for foam plastic interior signs in *covered and open mall buildings* provided the signs comply with Section 402.6.4.

2603.4.1.5 Roofing. Foam plastic insulation under a roof assembly or roof covering that is installed in accordance with the code and the manufacturer's instructions shall be separated from the interior of the building by wood structural panel sheathing not less than 0.47 inch (11.9 mm) in thickness bonded with exterior glue, with edges supported by blocking, tongue-and-groove joints or other approved type of edge support, or an equivalent material. A thermal barrier is not required for foam plastic insulation that is a part of a Class A, B or C roof-covering assembly, provided the assembly with the foam plastic insulation satisfactorily passes ~~FM 4450~~ NFPA 276 or UL 1256.

1508.1 General. The use of above-deck thermal insulation shall be permitted provided such insulation is covered with an *approved* roof covering and passes the tests of ~~FM 4450~~ NFPA 276 or UL 1256 when tested as an assembly.

Add new standard to Chapter 35 as follows:

NFPA 276-11, Standard Method of Fire Tests for Determining the Heat Release Rate of Roofing Assemblies with Combustible Above-Deck Roofing Components.

Reason: NFPA 276 is a consensus internal fire test identical to the FM Approvals roof deck calorimeter test contained in FM 4450.

Cost Impact: The code change proposal will not increase the cost of construction.

FS178-12

Public Hearing:	Committee:	AS	AM	D
	Assembly:	ASF	AMF	DF

2603.1-FS-SMITH-2603.4.1.5-FS-SMITH-1508.1-S-SMITH

FS179 – 12

2603.3

Proponent: Tony Crimi, A.C. Consulting Solutions Inc, representing North American Insulation Manufacturers Association (NAIMA) (tcrimi@sympatico.ca)

Revise as follows:

2603.3 Surface-burning characteristics. Unless otherwise indicated in this section, foam plastic insulation and foam plastic cores of manufactured assemblies shall have a flame spread index of not more than 75 and a smoke-developed index of not more than 450 where tested in the maximum thickness intended for use in accordance with ASTM E 84 or UL 723. Loose fill-type foam plastic insulation shall be tested as board stock for the flame spread and smoke-developed indexes.

Exceptions:

1. Smoke-developed index for interior *trim* as provided for in Section 2604.2.
2. In cold storage buildings, ice plants, food plants, food processing rooms and similar areas, foam plastic insulation where tested in a thickness of 4 inches (102 mm) shall be permitted in a thickness up to 10 inches (254 mm) where the building is equipped throughout with an automatic fire sprinkler system in accordance with Section 903.3.1.1. The approved *automatic sprinkler system* shall be provided in both the room and that part of the building in which the room is located.
3. Foam plastic insulation that is a part of a Class A, B or C roof-covering assembly provided the assembly with the foam plastic insulation satisfactorily passes FM 4450 or UL 1256. ~~The smoke-developed index shall not be limited for roof applications.~~
4. Foam plastic insulation greater than 4 inches (102 mm) in thickness shall have a maximum flame spread index of 75 and a smoke-developed index of 450 where tested at a minimum thickness of 4 inches (102 mm), provided the end use is approved in accordance with Section 2603.10 using the thickness and density intended for use.
5. Flame spread and smoke-developed indexes for foam plastic interior signs in *covered and open mall buildings* provided the signs comply with Section 402.6.4.

Reason: Fires in roofing materials can occur during installation or maintenance of roofing, during the normal course of operations, or during maintenance and installation of building equipment. While ASTM E108 and UL 790 are a means of evaluating fire spread, they do not measure smoke production. In this case, smoke development ratings for roofing insulations and coverings are inappropriately exempted in 2603.3 Exception #3, and in 2603.6.

Both the IBC and the IFC identify in Section 101.3 that, in part, that the purpose of the Codes is to provide protection from fire and other hazards attributed to the built environment and to provide safety to fire fighters and emergency responders during emergency operations. Although roofing materials are installed on the exterior of a building, the smoke from burning roof insulations can be a hazard to both firefighters and the environment. Air intakes are often installed through the roofing. In the event of a fire on the roof, smoke will be drawn back into the building through these intakes. Similarly, occupants of adjacent buildings and neighborhoods can also be affected by smoke emanating from combustible roof insulations. The waiver of the smoke developed requirements for roof insulations does not apply to any insulation other than foam plastic. This is not only inconsistent, but also not in keeping with the objectives of the Code, as identified in Chapter 1.

Emissions from fires in roofing materials have a serious impact on the environment. Not only are the combustion gases toxic at the site of the fire, but during a fire, very large quantities of particulates are also released into the environment. The particles consist among others of soot, tar, unburned materials, and inorganic debris. It should also be acknowledged that rooftop Occupancies are becoming increasingly popular. The existing provisions for rooftop structures in Chapter 15 are largely prescriptive and do not envision facilities such as restaurant seating, gardens, or performances on rooftops.

Even when a fire is contained within the building, sufficient heat can be generated through a metal roof deck to cause smoldering combustion and smoke release. While a smoke developed index of 450 is consistent with other sections of the IBC for foamed plastics. Several foam plastic insulation products have direct-to-steel-deck approvals from both FM and UL. FM approval for Class 1 roof systems based on passing FM 4450 and UL 1256. Both of these tests are specifically referenced in the IBC. The International Building Code (IBC) already waives the requirements for a thermal barrier for foam plastic roof insulation used in roof deck construction that complies with FM 4450 or UL 1256. Some minimum smoke developed rating should be maintained.

Cost Impact: This proposal does not increase the cost of construction.

FS179-12

Public Hearing:	Committee:	AS	AM	D
	Assembly:	ASF	AMF	DF

2603.3-FS-CRIMI

FS180 – 12

2603.4

Proponent: William E. Koffel, P.E., Koffel Associates, Inc., representing self (wkoffel@koffel.com)

Revise as follows:

2603.4 Thermal barrier. Except as provided for in Sections 2603.4.1 and 2603.10, foam plastic shall be separated from the interior of a building by an approved thermal barrier of ½- inch (12.7 mm) gypsum wallboard or a material that is tested in accordance with and meets the acceptance criteria of both the Temperature Transmission Fire Test and the Integrity Fire Test of NFPA 275. Penetrations of the thermal barrier shall be protected to maintain the integrity of the thermal barrier. Combustible concealed spaces shall comply with Section 718.

Reason: It is not uncommon to find penetrations of a thermal barrier. NFPA 275 does not include any provisions for the testing of penetrations. Therefore, one could interpret the Code to say that penetrations are not permitted. Unfortunately, no current test protocol specifically addresses penetrations of thermal barriers. Therefore, the language proposed is performance oriented and requires the registered design professional to document to the satisfaction of the building official (through the construction document process) how such penetrations are being protected.

Cost Impact: None

FS180-12

Public Hearing:	Committee:	AS	AM	D
	Assembly:	ASF	AMF	DF

2603.4-FS-KOFFEL

FS181 – 12

2603.4

Proponent: Marcelo M Hirschler, GBH International (gbhint@aol.com)

Revise as follows:

2603.4 Thermal barrier. Except as provided for in Sections 2603.4.1 and 2603.10, foam plastic shall be separated from the interior of a building by an approved thermal barrier of ½- inch (12.7 mm) gypsum wallboard or a material that is tested in accordance with and meets the acceptance criteria of both the Temperature Transmission Fire Test and the Integrity Fire Test of NFPA 275. If the integrity fire test is conducted in accordance with NFPA 286, the acceptance criteria shall be as indicated in section 803.1.2 of this code. Combustible concealed spaces shall comply with Section 718.

Reason: There has been some discussion about allowing as thermal barriers materials that cause flashover when tested to NFPA 286. That should not be allowed and this language will ensure that thermal barriers protect against flashover in the fire area.

Note that the integrity fire test of NFPA 275 can be conducted in accordance with NFPA 286, UL 1040, UL 1715 or FM 4880. In UL 1040, UL 1715 and FM 4880 pass/fail criteria are included and flashover is not permitted. NFPA 286 does not contain pass/fail criteria and the code must have its own acceptance criteria.

Cost Impact: None

FS181-12

Public Hearing:	Committee:	AS	AM	D
	Assembly:	ASF	AMF	DF

2603.4-FS-HIRSCHLER

FS182 – 12

2603.4.1.5

Proponent: Mike Ennis, representing SPRI Inc. (m.ennis@mac.com)

Delete and substitute as follows:

~~**2603.4.1.5 Roofing.** Foam plastic insulation under a roof assembly or roof covering that is installed in accordance with the code and the manufacturer's instructions shall be separated from the interior of the building by wood structural panel sheathing not less than 0.47 inch (11.9 mm) in thickness bonded with exterior glue, with edges supported by blocking, tongue and groove joints or other approved type of edge support, or an equivalent material. A thermal barrier is not required for foam plastic insulation that is a part of a Class A, B or C roof-covering assembly, provided the assembly with the foam plastic insulation satisfactorily passes FM 4450 or UL 1256.~~

2603.4.1.5 Roofing. The foam plastic insulation is a part of a Class A, B or C roof-covering assembly that is installed in accordance with the code and the manufacturer's instructions and is either constructed as described in 1 or tested as described in 2:

1. The roof assembly is separated from the interior of the building by wood structural panel sheathing not less than 0.47 inch (11.9 mm) in thickness bonded with exterior glue, with edges supported by blocking, tongue-and-groove joints or other approved type of edge support, or an equivalent material.
2. The assembly with the foam plastic insulation satisfactorily passes FM 4450 or UL 1256.

Reason: The proposed wording is intended to clarify exceptions for the use of a thermal barrier to separate foam plastic insulation from the interior of the building. The current wording does not clearly convey that there are two exceptions for the use of a thermal barrier. One is a prescriptive construction technique; the other describes specific testing requirements.

Cost Impact: This code change proposal will not increase the cost of construction.

FS182-12

Public Hearing:	Committee:	AS	AM	D
	Assembly:	ASF	AMF	DF

2603.4.1.5-S-Ennis

FS183 – 12

2603.4.1.6

Proponent: Rick Thornberry, P.E. representing the Cellulose Insulation Manufacturers Association (CIMA)

Revise as follows:

2603.4.1.6 Attics and crawl spaces. Within an attic or crawl space where entry is made only for service of utilities, foam plastic insulation shall be protected against ignition by 1 1/2-inch-thick (38 mm) mineral fiber insulation; 1/4-inch-thick (6.4 mm) wood structural panel, particleboard or hardboard; 3/8-inch (9.5 mm) gypsum wallboard, corrosion-resistant steel having a base metal thickness of 0.016 inch (0.4 mm); 1 1/2-inch-thick (38 mm) cellulose insulation in attic spaces only; or other approved material installed in such a manner that the foam plastic insulation is not exposed. The protective covering shall be consistent with the requirements for the type of construction.

Reason: The effect of this code change proposal is to make Section 2603.4.1.6 in the IBC consistent with Sections R316.5.3 and R316.5.4 in the IRC.

During the 2009/2010 code development cycle for the 2012 IRC, we submitted Code Change RB62-09/10 which was approved as modified to add the 1 1/2 inch thick cellulose insulation as a new Item 3.7 to the list of ignition barrier materials. The list of ignition barrier materials in Section 2603.4.1.6 is virtually identical to the list of those materials in Section R316.5.3 with the exception of the 1 1/2 inch thick cellulose insulation we are proposing to add.

The Reason submitted for Code Change RB62-09/10 is reproduced below:

We are proposing the use of 1-1/2 inch thick cellulose loose-fill insulation as another acceptable material for use as an ignition barrier to satisfy the requirements of R314.5.3 for the protection of foam plastic insulation in attics as an alternate to the thermal barrier required by Section 314.4. We are basing this proposal on the equivalent performance to that of Item No. 1 of this section which allows 1-1/2 inch thick mineral fiber insulation that by definition includes both mineral wool and glass fiber. Presently, cellulose insulation is recognized as being equivalent to mineral fiber insulation for the purpose of providing an additional 15 minutes of protection to a fire-resistance rated wall assembly utilizing wood stud construction as specified in Table 721.6.2(5) of the 2009 International Building Code (IBC).

Furthermore, when the Cellulose Insulation Manufacturers Association (CIMA) conducted the full scale fire tests to validate the comparable performance of cellulose insulation in achieving a one-hour fire-resistance rating for wood stud wall assemblies faced with various thicknesses of gypsum wallboard, they also measured the heat transfer through the cellulose insulation within the wall cavity to determine its resistance to the movement of heat through the assembly during the ASTM E119 fire test exposure. The test data indicated that approximately 1-1/2 inches of cellulose insulation was capable of limiting the temperature increase to an average maximum temperature of 250°F for a period of 15 minutes which is the same performance specified for a thermal barrier in Section R314.4.

Therefore, we believe that this proposal to include 1-1/2 inch thick cellulose loose-fill insulation as another material acceptable for an ignition barrier is appropriate.

Cost Impact: The code change proposal will not increase the cost of construction.

FS183-12

Public Hearing:	Committee:	AS	AM	D
	Assembly:	ASF	AMF	DF

2603.4.1.6-FS-THORNBERRY

FS184 – 12

2603.4.1.8

Proponent: Jeff Inks, Window and Door Manufacturers Association, representing the National Architectural Door Council (jinks@wdma.com)

Revise as follows:

2603.4.1.8 Exterior doors in buildings of Group R-2 or R-3. In occupancies classified as Group R-2 or R-3, foam-filled exterior entrance doors to individual *dwelling units* that do not require a fire-resistance rating shall be faced with aluminum, steel, fiberglass, wood or other approved materials.

Reason: The language in this section has remained unchanged since at least the 2000 IBC. However, use of non-rated insulated side-hinged exterior doors with facing materials other than wood is commonplace without resulting in any compromise in fire safety. They should be expressly provided for in this section rather than require special approval.

Cost Impact: This proposal will not increase the cost of construction.

FS184-12

Public Hearing:	Committee:	AS	AM	D
	Assembly:	ASF	AMF	DF

2603.4.1.8-FS-INKS

FS185 – 12

2603.4.1.13

Proponent: Michael D. Fischer, Kellen Company, representing self (mfischer@kellencompany.com)

Revise as follows:

2603.4.1.13 Type V construction. Foam plastic spray applied to a sill plate, ~~and~~ joist header and rim joist in of Type V construction is subject to all of the following:

1. The maximum thickness of the foam plastic shall be 3¹/₄ inches (82.6 mm).
2. The density of the foam plastic shall be in the range of 1.5 to 2.0 pcf (24 to 32 kg/m³).
3. The foam plastic shall have a flame spread index of 25 or less and an accompanying smoke-developed index of 450 or less when tested in accordance with ASTM E 84 or UL 723.

Reason: The current text in the 2012 IBC was revised to add new language for floors in 2603.4.1.13, but the charging paragraph was not modified to include floor joists in the list of framing members. The proposal closes the gap in the code by including rim and/or band joists with sill plates and headers, and ensures that the prescriptive requirements also apply to those components.

Cost Impact: The proposal will not increase the cost of construction.

FS185-12

Public Hearing:	Committee:	AS	AM	D
	Assembly:	ASF	AMF	DF

2603.4.1.13-FS-FISCHER

FS186 – 12

2603.5, 2603.5.1 (New)

Proponent: Jason Thompson, National Concrete Masonry Association, representing Masonry Alliance for Codes and Standards

Revise as follows:

2603.5 Exterior walls of buildings of Type I, II, III or IV construction of any height. *Exterior walls of buildings of Type I, II, III or IV construction of any height shall comply with Sections 2603.5.1 through 2603.5.7. Exterior walls of cold storage buildings required to be constructed of noncombustible materials, where the building is more than one story in height, shall also comply with the provisions of Sections 2603.5.1 through 2603.5.7.*

Exception: Walls constructed of concrete or masonry where the foam plastic insulation is covered on each face by a minimum of 1-inch (25 mm) thickness of masonry or concrete.

2603.5.1 Exterior walls of buildings of Type V construction *Exterior walls of buildings of Type V construction shall comply with Sections 2603.2, 2603.3 and 2603.4.*

(Renumber subsequent sections)

Reason: The purpose of this code change is to reinstate the exception that was contained in Section 2602.5.2.2 of the 1997 Uniform Building Code (UBC) that exempted masonry and concrete exterior walls containing foam plastic insulation from the requirements of that section where the foam plastic insulation is covered by a minimum of 1-inch thickness of masonry or concrete. Based on research of the ICC code merging process, it appears that this exception was inadvertently omitted when the three legacy model building codes were originally merged into the First Working Draft of the IBC.

Section 2602.5.2.2 of the 1997 UBC was titled "Buildings of Any Height." It contained requirements for regulating the use of foam plastic insulation in the exterior walls of buildings where the exterior walls were required to be of noncombustible construction. These requirements are very similar to the requirements that were in Section 2603.5 of the 2000 IBC, as well as the current requirements contained in Section 2603.5 of the 2012 IBC. The proposed wording for this new Exception, based on the 1997 UBC, is the same wording used in IBC Section 2603.4.1.1 Masonry or Concrete Construction that allows the omission of the thermal barrier that is otherwise required to protect foam plastic insulation from the interior of the building. And it is similar to Item 2 in IBC Section 2603.5.7 Ignition that exempts exterior wall assemblies containing foam plastic insulation from being tested in accordance with NFPA 268 to determine ignition resistance to an exterior radiant heat source where the assembly is protected on the exterior with a minimum 1-inch thickness of concrete or masonry.

In a review of the legacy codes and development of the IBC there does not appear to be any technical reason justifying why this Exception was not included or should not be reinstated, nor are we aware of any adverse fire experience that precludes its application.

Cost Impact: The code change will not increase the cost of construction.

FS186-12

Public Hearing:	Committee:	AS	AM	D
	Assembly:	ASF	AMF	DF

2603.5-FS-THOMPSON

FS187 – 12

2603.5

Proponent: David S. Collins, FAIA, The Preview Group, Inc., representing The American Institute of Architects (dcollins@preview-group.com); Henry Green, President, National Institute of Building Sciences, representing NIBS BETEC Committee (hgreen@nibs.org)

Revise as follows:

2603.5 Foam plastic insulation in exterior walls of buildings of any height. Exterior walls of buildings of Type I, II, III or IV construction of any height including foam plastic insulation shall comply with Sections 2603.5.1 through 2603.5.78.

2603.5.1 Exterior walls of Cold Storage Buildings. Exterior walls of cold storage buildings required by Section 503.1 to be constructed of noncombustible materials, where the building is more than one story in height, shall ~~also~~ comply with the provisions of Sections 2603.5.1 through 2603.5.78.

2603.5.2 Exterior walls of Type V Construction. Exterior walls of buildings of Type V construction shall comply with Sections 2603.2, 2603.3 and 2603.4.

2603.5.3 Buildings of Type I, II, III or IV Construction. Foam plastic insulation in exterior walls of buildings of Type I, II, III or IV construction shall comply with Section 2603.5.3.1, 2603.5.3.2, 2603.5.3 or 2603.5.4.

2603.5.3.1 One-story buildings complying with Section 2603.4.1.4.

2603.5.3.2 Building shall be sprinklered throughout in accordance with Section 903.3.1.1 or 903.3.1.2.

2603.5.3.3 The exterior walls shall be fireblocked per Section 718.2.6.

2603.5.3.4 The exterior wall assembly shall be tested in accordance with and comply with the acceptance criteria of NFPA 285.

~~**2603.5.1 Fire-resistance-rated walls.** Where the wall is required to have a fire-resistance rating, data based on tests conducted in accordance with ASTM E 119 or UL 263 shall be provided to substantiate that the fire-resistance rating is maintained.~~

~~**2603.5.2 2603.5.4 Thermal barrier.** Any foam plastic insulation shall be separated from the building interior by a thermal barrier meeting the provisions of Section 2603.4, unless special approval is obtained on the basis of Section 2603.10.~~

Exception: One-story buildings complying with Section 2603.4.1.4.

~~**2603.5.3 2603.5.5 Potential heat.** The potential heat of foam plastic insulation in any portion of the wall or panel shall not exceed the potential heat expressed in Btu per square feet (mJ/m²) of the foam plastic insulation contained in the wall assembly tested in accordance with Section 2603.5.5.~~

~~The potential heat of the foam plastic insulation shall be determined by tests conducted in accordance with NFPA 259 and the results shall be expressed in Btu per square feet (mJ/m²).~~

Exception: One-story buildings complying with Section 2603.4.1.4.

~~**2603.5.4 2603.5.6 Flame spread and smoke-developed indexes.** Foam plastic insulation, exterior coatings and facings shall be tested separately in the thickness intended for use, but not to exceed 4~~

inches (102 mm), and shall each have a flame spread index of 25 or less and a smoke-developed index of 450 or less as determined in accordance with ASTM E 84 or UL 723.

Exception: Prefabricated or factory-manufactured panels having minimum 0.020-inch (0.51 mm) aluminum facings and a total thickness of 1/4 inch (6.4 mm) or less are permitted to be tested as an assembly where the foam plastic core is not exposed in the course of construction.

~~**2603.5.5 Vertical and lateral fire propagation.** The exterior wall assembly shall be tested in accordance with and comply with the acceptance criteria of NFPA 285.~~

~~**Exception:** One-story buildings complying with Section 2603.4.1.4.~~

(Renumber subsequent sections)

Reason: In 1978, the U.S. Department of Energy (DOE) initiated a national program plan to address building enclosure systems. This program evolved into one of the National Institute of Building Science's first councils, the Building Enclosure Technology and Environment Council (BETEC). Today, DOE and more than 125 corporate and individual members support BETEC. An elected Board of Direction guides the Council. Government agency and association personnel, design and construction professionals, researchers and academics serve on BETEC committees and working groups, propose and review research, and organize symposia and publications.

Currently, Section 2603.5 requires all foam plastic exterior insulation materials to conform to the limits of NFPA 285. This test replicates the response of materials to a fire extending through an exterior window of a building. The code does not differentiate as to whether there is a potential for such a fire to occur in a building. Flashover fires which would cause the flame to break out of the building will not occur in a building that has a fully operational sprinkler system. Similar provisions in the code for other materials that are combustible and may lead to vertical and lateral spread of fire are required to provide fireblocking. In recreating Section 2603.5 we have incorporated various options to the use of this testing to address the risk of fire spreading on the exterior wall of a building where foam plastic insulation is found.

2603.5 The existing section includes three separate criteria, none of which has anything to do with height except for the provisions for cold storage buildings that only applies when they are over one story in height, so the title of the section is incorrect. In addition, to avoid additional confusion this code change breaks the section down into its various parts.

New 2603.5.1 The requirement for combustible or noncombustible walls is based on the construction type allowed in Section 503.1. The use of the term "also" implies there are other requirements that are not clearly spelled out.

New 2603.5.3 This is a new section that reflects the requirements for the use of combustible materials on the exterior of a building. The maximum height of an unsprinklered building is 55 feet to the occupied floor per Section 903.2.11.3. Current requirements for protection of combustible wood veneer materials on the exterior of a building are limited in Section 1405.5 to 40 feet in height. Fireblocking is required in Section 718.2.6 for concealed spaces on the exterior of a building.

2603.5.1 This existing section in the code is redundant with Section 703 of the IBC which requires all fire resistance rated walls to conform with ASTM E119 or UL 263. It isn't necessary to state everywhere in the code that if a wall is required to be fire resistance rated that it must pass these tests.

Cost Impact: The change will reduce the cost of construction.

FS187-12

Public Hearing:	Committee:	AS	AM	D
	Assembly:	ASF	AMF	DF

2603.5-FS-COLLINS-GREEN

FS188 – 12

2603.6

Proponent: Tony Crimi, A.C. Consulting Solutions Inc, representing North American Insulation Manufacturers Association (NAIMA) (tcrimi@sympatico.ca)

Revise as follows:

2603.6 Roofing. Foam plastic insulation meeting the requirements of Sections 2603.2, 2603.3 and 2603.4 shall be permitted as part of a roof-covering assembly, provided the assembly with the foam plastic insulation is a Class A, B or C roofing assembly where tested in accordance with ASTM E 108 or UL 790, and conforms to the smoke-developed requirements of Chapter 8.

Reason: Fires in roofing materials can occur during installation or maintenance of roofing, during the normal course of operations, or during maintenance and installation of building equipment. While ASTM E108 and UL 790 are a means of evaluating fire spread, they do not measure smoke production. In this case, smoke development ratings for roofing insulations and coverings are inappropriately exempted in 2603.3 Exception #3, and in 2603.6.

Both the IBC and the IFC identify in Section 101.3 that, in part, that the purpose of the Codes is to provide protection from fire and other hazards attributed to the built environment and to provide safety to fire fighters and emergency responders during emergency operations. Although roofing materials are installed on the exterior of a building, the smoke from burning roof insulations can be a hazard to both firefighters and the environment. Air intakes are often installed through the roofing. In the event of a fire on the roof, smoke will be drawn back into the building through these intakes. Similarly, occupants of adjacent buildings and neighborhoods can also be affected by smoke emanating from combustible roof insulations. The waiver of the smoke developed requirements for roof insulations does not apply to any insulation other than foam plastic. This is not only inconsistent, but also not in keeping with the objectives of the Code, as identified in Chapter 1.

Emissions from fires in roofing materials have a serious impact on the environment. Not only are the combustion gases toxic at the site of the fire, but during a fire, very large quantities of particulates are also released into the environment. The particles consist among others of soot, tar, unburned materials, and inorganic debris. It should also be acknowledged that rooftop Occupancies are becoming increasingly popular. The existing provisions for rooftop structures in Chapter 15 are largely prescriptive and do not envision facilities such as restaurant seating, gardens, or performances on rooftops.

Even when a fire is contained within the building, sufficient heat can be generated through a metal roof deck to cause smoldering combustion and smoke release. While a smoke developed index of 450 is consistent with other sections of the IBC for foamed plastics. Several foam plastic insulation products have direct-to-steel-deck approvals from both FM and UL. FM approval for Class 1 roof systems based on passing FM 4450 and UL 1256. Both of these tests are specifically referenced in the IBC. The International Building Code (IBC) already waives the requirements for a thermal barrier for foam plastic roof insulation used in roof deck construction that complies with FM 4450 or UL 1256. Some minimum smoke developed rating should be maintained.

Cost Impact: This proposal should not increase the cost of construction.

FS188-12

Public Hearing:	Committee:	AS	AM	D
	Assembly:	ASF	AMF	DF

2603.6-FS-CRIMI

FS189 – 12

2603.7

Proponent: Marcelo M Hirschler, GBH International (gbhint@aol.com)

Delete and substitute as follows:

~~**2603.7 Interior finish in plenums.** Foam plastic insulation used as interior wall or ceiling finish in plenums shall comply with one or more of the following:~~

- ~~1. The foam plastic insulation shall be separated from the plenum by a thermal barrier complying with Section 2603.4 and shall exhibit a flame spread index of 75 or less and a smoke-developed index of 450 or less when tested in accordance with ASTM E 84 or UL 723 at the thickness and density intended for use.~~
- ~~2. The foam plastic insulation shall exhibit a flame spread index of 25 or less and a smoke-developed index of 50 or less when tested in accordance with ASTM E 84 or UL 723 at the thickness and density intended for use and shall meet the acceptance criteria of Section 803.1.2 when tested in accordance with NFPA 286.~~
- ~~3. The foam plastic insulation shall be covered by corrosion-resistant steel having a base metal thickness of not less than 0.0160 inch (0.4 mm) and shall exhibit a flame spread index of 75 or less and a smoke-developed index of 450 or less when tested in accordance with ASTM E 84 or UL 723 at the thickness and density intended for use.~~

~~**2603.7 Foam plastic insulation used as interior finish or interior trim in plenums.** Foam plastic insulation used as interior wall or ceiling finish, or as interior trim, in plenums shall exhibit a flame spread index of 75 or less and a smoke-developed index of 450 or less when tested in accordance with ASTM E 84 or UL 723 and shall also comply with one or more of Sections 2603.7.1, 2603.7.2 and 2607.1.3.~~

~~**2603.7.1 Separation required.** The foam plastic insulation shall be separated from the plenum by a thermal barrier complying with Section 2603.4 and shall exhibit a flame spread index of 75 or less and a smoke-developed index of 450 or less when tested in accordance with ASTM E 84 or UL 723 at the thickness and density intended for use.~~

~~**2603.7.2 Approval.** The foam plastic insulation shall exhibit a flame spread index of 25 or less and a smoke-developed index of 50 or less when tested in accordance with ASTM E 84 or UL 723 at the thickness and density intended for use and shall meet the acceptance criteria of Section 803.1.2 when tested in accordance with NFPA 286. The foam plastic insulation shall be approved based on tests conducted in accordance with Section 2603.10.~~

~~**2603.7.3 Covering.** The foam plastic insulation shall be covered by corrosion-resistant steel having a base metal thickness of not less than 0.0160 inch (0.4 mm) and shall exhibit a flame spread index of 75 or less and a smoke-developed index of 450 or less when tested in accordance with ASTM E 84 or UL 723 at the thickness and density intended for use.~~

(Renumber subsequent sections)

~~**2603.8 Interior trim in plenums.** Foam plastic insulation used as interior trim in plenums shall comply with the requirements of Section 2603.7.~~

Reason: Section 602.2.1.5 of the IMC has identical requirements to those of sections 2603.7 and 2603.8 of the IBC (see IMC text below). Section 603.1, item 2, of the IBC states (exception 25) that materials exposed within plenums should comply with the IMC. Therefore it is best if section 2603.7 of the IBC is simply extracted from the IMC.

Note that the IBC and IMC text both reference section 2603.10 of the IBC but that this section will be renumbered as 2603.9 if the proposal is accepted.

M602.2.1.5 Foam plastic insulation. Foam plastic insulation used as interior wall or ceiling finish, or as interior trim, in plenums shall exhibit a flame spread index of 75 or less and a smoke-developed index of 450 or less when tested in accordance with ASTM E 84 or UL 723 and shall also comply with one or more of Sections 602.2.1.5.1, 602.2.1.5.2 and 602.2.1.5.3.

M602.2.1.5.1 Separation required. The foam plastic insulation shall be separated from the plenum by a thermal barrier complying with Section 2603.4 of the *International Building Code* and shall exhibit a flame spread index of 75 or less and a smoke-developed index of 450 or less when tested in accordance with ASTM E 84 or UL 723 at the thickness and density intended for use.

M602.2.1.5.2 Approval. The foam plastic insulation shall exhibit a flame spread index of 25 or less and a smoke-developed index of 50 or less when tested in accordance with ASTM E 84 or UL 723 at the thickness and density intended for use and shall meet the acceptance criteria of Section 803.1.2 of the *International Building Code* when tested in accordance with NFPA 286. The foam plastic insulation shall be approved based on tests conducted in accordance with Section 2603.10 of the *International Building Code*.

M602.2.1.5.3 Covering. The foam plastic insulation shall be covered by corrosion-resistant steel having a base metal thickness of not less than 0.0160 inch (0.4 mm) and shall exhibit a flame spread index of 75 or less and a smoke-developed index of 450 or less when tested in accordance with ASTM E 84 or UL 723 at the thickness and density intended for use.

Cost Impact: None

Analysis statement: If this proposal is approved for inclusion in the 2015 IBC, future maintenance of Section 2603.7 by the Mechanical Code Committee will be considered by the International Code Correlation Committee.

FS189-12

Public Hearing:	Committee:	AS	AM	D
	Assembly:	ASF	AMF	DF

2603.7-FS-HIRSCHLER

FS190 – 12

2603.10, 2603.10.1

Proponent: Jesse J. Beitel, Hughes Associates, Inc., representing The Extruded Polystyrene Foam Association (jbeitel@haifire.com)

Revise as follows:

2603.10 Special approval. Foam plastic shall not be required to comply with the requirements of Sections 2603.4, 2603.6, 2603.7 and through 2603.8 where specifically approved based on large-scale tests such as, but not limited to, NFPA 286 (with the acceptance criteria of Section 803.2), FM 4880, UL 1040 or UL 1715. Such testing shall be related to the actual end-use configuration and be performed on the finished manufactured foam plastic assembly in the maximum thickness intended for use. Foam plastics that are used as interior finish on the basis of special tests shall also conform to the flame spread and smoke developed requirements of Chapter 8. Assemblies tested shall include seams, joints and other typical details used in the installation of the assembly and shall be tested in the manner intended for use.

~~**2603.10.1 Exterior walls.** Testing based on Section 2603.10 shall not be used to eliminate any component of the construction of an exterior wall assembly when that component was included in the construction that has met the requirements of Section 2603.5.5.~~

Reason: This proposal prevents using a room/corner fire test to eliminate the requirements of 2603.5. A room corner test cannot definitively determine the vertical and lateral fire propagation characteristics of an exterior wall assembly and should not be used to eliminate the need for the appropriate test namely NFPA 285. Additionally, with the proposed change, Section 2603.10.1 is no longer needed.

Cost Impact: This code change proposal will not increase the cost of construction.

FS190-12

Public Hearing:	Committee:	AS	AM	D
	Assembly:	ASF	AMF	DF

2603.10-FS-BEITEL

FS191 – 12

2603.10, 2603.10.2 (New)

Proponent: Marcelo M Hirschler, GBH International (gbhint@aol.com)

Revise as follows:

2603.10 Special approval. Foam plastic shall not be required to comply with the requirements of Sections 2603.4 through 2603.8 where specifically approved based on testing in accordance with large-scale tests such as, but not limited to, NFPA 286, (with the acceptance criteria of Section 803.2), ~~FM 4880, UL 1040 or UL 1715~~. Such testing shall be related to the actual end-use configuration and be performed on the finished manufactured foam plastic assembly in the maximum thickness intended for use. Foam plastics that are used as interior finish on the basis of special tests shall also conform to the flame spread and smoke developed requirements of Chapter 8. Assemblies tested shall include seams, joints and other typical details used in the installation of the assembly and shall be tested in the manner intended for use.

2603.10.1 Exterior walls. Testing based on Section 2603.10 shall not be used to eliminate any component of the construction of an exterior wall assembly when that component was included in the construction that has met the requirements of Section 2603.5.5.

2603.10.2 Listed systems. Listed foam plastics tested to FM 4880, UL 1040 and UL 1715 shall be permitted to be used for the application for which they are listed.

Reason: Of the four tests included in this section, three have been in place since the legacy codes, namely FM 4880, UL 1040 and UL 1715. None of these tests actually measure smoke obscuration, while NFPA 286 does, and that is included in the criteria of section 803.2. In the case of UL 1715 smoke obscuration is being measured, but normally only qualitatively.

The ignition sources in these legacy tests are wood cribs or wood pallets and the one in NFPA 286 is a gas burner.

In actual fact, two of these legacy tests are not really intended for testing foam plastics as interior finish but are intended for systems intended for insulated wall construction (UL 1040) or insulated roof and wall construction (FM 4880). They are also extremely severe or onerous tests, since UL 1040 uses a 764 pound wood crib and FM 4880 uses a series of wood pallets adding up to 750 pounds (340 kg). Therefore the probability of them being used for approval of foam plastics for interior finish is low.

UL 1715 is actually intended for testing interior finish materials but exposes the test specimen on two walls only (and only 8 ft of the 12 ft wall), in a corner, to a 30 pound wood crib. NFPA 286 uses the same room dimensions except that the room is actually a full room and the test specimen is placed covering three walls and the ceiling, and the ignition source is a gas burner at 40 kW and then at 160 kW, with direct heat and smoke release and flame spread measurements.

Cost Impact: None

FS191-12

Public Hearing:	Committee:	AS	AM	D
	Assembly:	ASF	AMF	DF

2603.10-FS-HIRSCHLER

FS192 – 12
2603.11 (New), Chapter 35

Proponent: Jay Crandell, ARES Consulting, representing the Foam Sheathing Committee of the American Chemistry Council- Plastics Division (jcrandell@aresconsulting.biz)

THIS CODE CHANGE WILL BE HEARD BY THE IBC STRUCTURAL COMMITTEE. SEE THE TENTATIVE HEARING ORDER FOR THIS COMMITTEE.

Add new text as follows:

2603.11 Wind Resistance. Foam plastic insulation complying with ASTM C 578 and ASTM C 1289 and used as exterior wall sheathing on framed wall assemblies shall comply with ANSI/FS 100 for wind pressure resistance.

Add new standard to Chapter 35 as follows:

Structural Building Components Association (SBCA)
6300 Enterprise Lane
Madison, Wisconsin 53719

Standard Reference number	Title	Referenced in code section
<u>ANSI/FS 100-12</u>	<u>Standard Requirements for Wind Pressure Resistance of Foam Plastic Insulating Sheathing Used in Exterior Wall Covering Assemblies</u>	<u>2603.11</u>

Reason: This ANSI standard (FS 100-12) is needed to address the use of foam plastic insulating sheathing in exterior wall covering assemblies where resistance to wind pressure is required. This standard provides a methodology by which a manufacturer can qualify their product, through testing, to meet the requirements of the I-codes in establishing the wind pressure resistance of the product. It also provides for on-going quality control procedures to ensure that the product continues to meet its qualified wind pressure resistance. The ANSI standard supplements the applicable ASTM materials standards also referenced in the code change proposal. The ANSI standard was approved by the standard project committee and in process of its public comment phase at the time this proposal was due to ICC (Jan 3, 2012). The current version of the standard is available for review at www.sbcindustry.com/fs100draft. It is expected that copies of the completed ANSI standard will be available prior to the code development hearings.

As a formatting note to ICC staff, there are other proposals by the proponent dealing with separate topics for wall sheathing applications of foam sheathing and they are being proposed with the same new section number (2306.11). Presuming that this proposal passes as well as any of the others, it is the proponent's desire to have them all organized under a Section 2306.11 for wall sheathing applications of foam plastic insulation.

Cost Impact: The code change proposal will not increase the cost of construction.

FS192-12

Public Hearing: Committee: AS AM D
 Assembly: ASF AMF DF

2603.11 (NEW) #1-FS-CRANDELL

FS193– 12

2603.11 (New)

Proponent: Jay Crandell, ARES Consulting, representing the Foam Sheathing Committee of the American Chemistry Council- Plastics Division (jcrandell@aresconsulting.biz)

THIS CODE CHANGE WILL BE HEARD BY THE IBC STRUCTURAL COMMITTEE. SEE THE TENTATIVE HEARING ORDER FOR THIS COMMITTEE.

Add new text as follows:

2603.11 Cladding attachment over foam sheathing to masonry or concrete wall construction.
Cladding shall be specified and installed in accordance with Chapter 14 and the cladding manufacturer's installation instructions or an approved design. Foam sheathing shall be attached to masonry or concrete construction in accordance with the insulation manufacturer's installation instructions or an approved design. Furring and furring attachments through foam sheathing shall be designed to resist design loads determined in accordance with Chapter 16, including support of cladding weight as applicable. Fasteners used to attach cladding or furring through foam sheathing to masonry or concrete substrates shall be approved for application into masonry or concrete material and shall be installed in accordance with the fastener manufacturer's installation instructions.

Exceptions:

1. Where the cladding manufacturer has provided approved installation instructions for application over foam sheathing and connection to a masonry or concrete substrate, those requirements shall apply.
2. For exterior insulation and finish systems, refer to Section 1408.
3. For anchored masonry or stone veneer installed over foam sheathing, refer to Section 1405.

Reason: Two other proposals submitted on the topic of attachment of cladding through foam sheathing address wood and steel framing applications based on experimental data and rational analysis addressed in the reason statements for those proposals. Similar solutions and guidance for attachment of cladding to masonry/concrete walls through foam sheathing is needed. Research is not yet available to justify prescriptive "off-the-shelf" solutions with standardized types of concrete/masonry fasteners. Also, many fasteners best suited for this application are proprietary and approved data and design is the best approach. Therefore, this proposal requires engineered design of cladding connections through foam sheathing to masonry/concrete. The exceptions recognize cases where appropriate attachment solutions may already exist.

Cost Impact: The code change proposal will not increase the cost of construction.

FS193-12

Public Hearing:	Committee:	AS	AM	D
	Assembly:	ASF	AMF	DF

2603.11 (NEW) #2-FS-CRANDELL

FS194 – 12

2603.11 (New), 2603.11.1 (New), Table 2603.11.1 (New), 2603.11.2 (New), Table 2603.11.2 (New)

Proponent: Jay Crandell, ARES Consulting, representing the Foam Sheathing Committee of the American Chemistry Council- Plastics Division (jcrandell@aresconsulting.biz)

THIS CODE CHANGE WILL BE HEARD BY THE IBC STRUCTURAL COMMITTEE. SEE THE TENTATIVE HEARING ORDER FOR THIS COMMITTEE.

Add new text as follows:

2603.11 Cladding attachment over foam sheathing to steel framing. Cladding shall be specified and installed in accordance with Chapter 14 and the cladding manufacturer’s installation instructions. Where used, furring and furring attachments shall be designed to resist design loads determined in accordance with Chapter 16. In addition, the cladding or furring attachments through foam sheathing to framing shall meet or exceed the minimum fastening requirements of Section 2603.11.1, 2603.11.2, or an approved design for support of cladding weight.

Exceptions:

1. Where the cladding manufacturer has provided approved installation instructions for application over foam sheathing, those requirements shall apply.
2. For exterior insulation and finish systems, refer to Section 1408.
3. For anchored masonry or stone veneer installed over foam sheathing; refer to Section 1405.

2603.11.1 Direct attachment. Where cladding is installed directly over foam sheathing without the use of furring, cladding minimum fastening requirements to support the cladding weight shall be as specified in Table 2603.11.1.

TABLE 2603.11.1 CLADDING MINIMUM FASTENING REQUIREMENTS FOR DIRECT ATTACHMENT OVER FOAM PLASTIC SHEATHING TO SUPPORT CLADDING WEIGHT¹

<u>Cladding Fastener Through Foam Sheathing into:</u>	<u>Cladding Fastener -Type and Minimum Size²</u>	<u>Cladding Fastener Vertical Spacing (inches)</u>	<u>Maximum Thickness of Foam Sheathing³ (inches)</u>					
			<u>16”oc Fastener Horizontal Spacing</u>			<u>24”oc Fastener Horizontal Spacing</u>		
			<u>Cladding Weight:</u>			<u>Cladding Weight:</u>		
			<u>3 psf</u>	<u>11 psf</u>	<u>25 psf</u>	<u>3 psf</u>	<u>11 psf</u>	<u>25 psf</u>
<u>Steel Framing (minimum penetration of steel thickness + 3 threads)</u>	<u>#8 screw into 33 mil steel or thicker</u>	<u>6</u>	<u>3</u>	<u>3</u>	<u>1.5</u>	<u>3</u>	<u>2</u>	<u>DR</u>
		<u>8</u>	<u>3</u>	<u>2</u>	<u>0.5</u>	<u>3</u>	<u>1.5</u>	<u>DR</u>
		<u>12</u>	<u>3</u>	<u>1.5</u>	<u>DR</u>	<u>3</u>	<u>0.75</u>	<u>DR</u>
	<u>#10 screw into 33 mil steel</u>	<u>6</u>	<u>4</u>	<u>3</u>	<u>2</u>	<u>4</u>	<u>3</u>	<u>0.5</u>
		<u>8</u>	<u>4</u>	<u>3</u>	<u>1</u>	<u>4</u>	<u>2</u>	<u>DR</u>
		<u>12</u>	<u>4</u>	<u>2</u>	<u>DR</u>	<u>3</u>	<u>1</u>	<u>DR</u>
	<u>#10 screw into 43 mil steel or thicker</u>	<u>6</u>	<u>4</u>	<u>4</u>	<u>3</u>	<u>4</u>	<u>4</u>	<u>2</u>
		<u>8</u>	<u>4</u>	<u>4</u>	<u>2</u>	<u>4</u>	<u>3</u>	<u>1.5</u>
		<u>12</u>	<u>4</u>	<u>3</u>	<u>1.5</u>	<u>4</u>	<u>3</u>	<u>DR</u>

For SI: 1 inch = 25.4 mm; 1 pound per square foot (psf) = 0.0479 kPa

DR = design required

o.c. = on center

- a. Steel framing shall be minimum 33 ksi steel for 33 mil and 43 mil steel and 50 ksi steel for 54 mil steel or thicker.
- b. Screws shall comply with the requirements of AISI S200.
- c. Foam sheathing shall have a minimum compressive strength of 15 psi in accordance with ASTM C 578 or ASTM C 1289.

2603.11.2 Furred cladding attachment. Where steel or wood furring is used to attach cladding over foam sheathing, furring minimum fastening requirements to support the cladding weight shall be as specified in Table 2603.11.2. Where placed horizontally, wood furring shall be preservative treated wood in accordance with Section 2303.1.8 or naturally durable wood and fasteners shall be corrosion resistant in accordance Section 2304.9.5. Steel furring shall have a minimum G60 galvanized coating.

TABLE 2603.11.2 FURRING MINIMUM FASTENING REQUIREMENTS FOR APPLICATION OVER FOAM PLASTIC SHEATHING TO SUPPORT CLADDING WEIGHT¹

Furring Material	Framing Member	Fastener Type and Minimum Size ²	Minimum Penetration into Wall Framing (inches)	Fastener Spacing in Furring (inches)	Maximum Thickness of Foam Sheathing ⁴ (inches)					
					16"oc FURRING ⁵			24"oc FURRING ⁵		
					Cladding Weight:			Cladding Weight:		
					3 psf	11 psf	25 psf	3 psf	11 psf	25 psf
Minimum 33mil Steel Furring or Minimum 1x Wood Furring ³	33 mil Steel Stud	#8 screw	Steel thickness + 3 threads	12	3	1.5	DR	3	0.5	DR
				16	3	1	DR	2	DR	DR
				24	2	DR	DR	2	DR	DR
		#10 screw	Steel thickness + 3 threads	12	4	2	DR	4	1	DR
				16	4	1.5	DR	3	DR	DR
				24	3	DR	DR	2	DR	DR
	43 mil or thicker Steel Stud	#8 Screw	Steel thickness + 3 threads	12	3	1.5	DR	3	0.5	DR
				16	3	1	DR	2	DR	DR
				24	2	DR	DR	2	DR	DR
		#10 screw	Steel thickness + 3 threads	12	4	3	1.5	4	3	DR
				16	4	3	0.5	4	2	DR
				24	4	2	DR	4	0.5	DR

For SI: 1" = 25.4 mm; 1 pound per square foot (psf) = 0.0479 kPa.

DR = design required

o.c. = on center

1. Wood furring shall be Spruce-Pine-Fir or any softwood species with a specific gravity of 0.42 or greater. Steel furring shall be minimum 33 ksi steel. Steel studs shall be minimum 33 ksi steel for 33mil and 43 mil thickness and 50 ksi steel for 54 mil steel or thicker.
2. Screws shall comply with the requirements of AISI S200.
3. Where the required cladding fastener penetration into wood material exceeds 3/4 inch (19.1 mm) and is not more than 1-1/2 inches (38.1 mm), a minimum 2 inch (51 mm) nominal wood furring shall be used or an approved design.
4. Foam sheathing shall have a minimum compressive strength of 15 psi in accordance with ASTM C 578 or ASTM C 1289.
5. Furring shall be spaced a maximum of 24 inches (610 mm) on center, in a vertical or horizontal orientation. In a vertical orientation, furring shall be located over wall studs and attached with the required fastener spacing. In a horizontal orientation, the indicated 8 inch (203.2 mm) and 12 inch (304.8 mm) fastener spacing in furring shall be achieved by use of two fasteners into studs at 16 inches (406.4 mm) and 24 inches (610 mm) on center, respectively.

Reason: The proposed cladding connection requirements already exist in the New York State Energy Code which is based on the 2009 IECC. Similar requirements for the IECC 2012 were considered last code cycle, but it was clearly expressed that these provisions are a better fit for the building code. These requirements fill an important need in the IBC provisions for exterior wall covering assemblies that include foam plastic insulation.

The proposed requirements are based on a project sponsored by the New York State Energy Research and Development Agency (NYSERDA) and the Steel Framing Alliance. The project report is available for download at [http://data.memberclicks.com/site/sfa/NYSERDA_TASK_3_REPORT%20-%20FINAL_\(3-22-10\).pdf](http://data.memberclicks.com/site/sfa/NYSERDA_TASK_3_REPORT%20-%20FINAL_(3-22-10).pdf). The report explains the technical basis for the proposed requirements.

The purpose of the NYSERDA project was to develop prescriptive fastening requirements for cladding materials installed over foam sheathing to ensure adequate performance. The project included testing of cladding attachments through various thicknesses of foam sheathing using various fastener types on steel frame wall assemblies. Supplemental testing also was sponsored by the Foam Sheathing Coalition (lab report available at www.foamshathing.org) to address attachments to wood framing and the resulting data is included in the data set analyzed and presented in the NYSERDA project report. The proposed cladding attachment requirements and foam sheathing thickness limits are based on rational analysis verified by the extensive test data to control cladding

connection movement to no more than 0.015" slip under cladding weight or dead load. This deflection controlled approach resulted in safety factors commonly in the range of 5 to 8 relative to average shear capacity.
Cost Impact: The code change proposal will not increase the cost of construction.

FS194-12

Public Hearing:	Committee:	AS	AM	D
	Assembly:	ASF	AMF	DF

2603.11 (NEW) #3-FS-CRANDELL

FS195 – 12

2603.11 (New), 2603.11.1 (New), Table 2603.11.1 (New), 2603.11.2 (New), Table 2603.11.2 (New)

Proponent: Jay Crandell, ARES Consulting, representing the Foam Sheathing Committee of the American Chemistry Council- Plastics Division (jcrandell@aresconsulting.biz)

THIS CODE CHANGE WILL BE HEARD BY THE IBC STRUCTURAL COMMITTEE. SEE THE TENTATIVE HEARING ORDER FOR THIS COMMITTEE.

Add new text as follows:

2603.11 Cladding attachment over foam sheathing to wood framing. Cladding shall be specified and installed in accordance with Chapter 14 and the cladding manufacturer’s installation instructions. Where used, furring and furring attachments shall be designed to resist design loads determined in accordance with Chapter 16. In addition, the cladding or furring attachments through foam sheathing to framing shall meet or exceed the minimum fastening requirements of Section 2603.11.1, 2603.11.2, or an approved design for support of cladding weight.

Exceptions:

1. Where the cladding manufacturer has provided approved installation instructions for application over foam sheathing, those requirements shall apply.
2. For exterior insulation and finish systems, refer to Section 1408.
3. For anchored masonry or stone veneer installed over foam sheathing, refer to Section 1405.

2603.11.1 Direct attachment. Where cladding is installed directly over foam sheathing without the use of furring, cladding minimum fastening requirements to support the cladding weight shall be as specified in Table 2603.11.1.

TABLE 2603.11.1 CLADDING MINIMUM FASTENING REQUIREMENTS FOR DIRECT ATTACHMENT OVER FOAM PLASTIC SHEATHING TO SUPPORT CLADDING WEIGHT¹

Cladding Fastener Through Foam Sheathing into:	Cladding Fastener -Type and Minimum Size ^b	Cladding Fastener Vertical Spacing (inches)	Maximum Thickness of Foam Sheathing ³ (inches)					
			16" o.c. Fastener Horizontal Spacing			24" o.c. Fastener Horizontal Spacing		
			Cladding Weight:			Cladding Weight:		
			3 psf	11 psf	25 psf	3 psf	11 psf	25 psf
Wood Framing (minimum 1-1/4 inch penetration)	0.113" diameter nail	6	4	3	1	4	2	0.75
		8	4	2	0.75	4	1.5	DR
		12	4	1.5	DR	3	0.75	DR
	0.120" diameter nail	6	4	3	1.5	4	2	0.75
		8	4	2	1	4	1.5	0.5
		12	4	1.5	0.5	3	1	DR
	0.131" diameter nail	6	4	4	1.5	4	3	1
		8	4	3	1	4	2	0.75
		12	4	2	0.75	4	1	DR

For SI: 1 inch = 25.4 mm; 1 pound per square foot (psf) = 0.0479 kPa

DR = design required

o.c. = on center

1. Wood framing shall be Spruce-Pine-Fir or any wood species with a specific gravity of 0.42 or greater in accordance with AFPA/NDS.
2. Nail fasteners shall comply with ASTM F1667, except nail length shall be permitted to exceed ASTM F1667 standard lengths.

3. Foam sheathing shall have a minimum compressive strength of 15 psi in accordance with ASTM C 578 or ASTM C 1289.

2603.11.2 Furred cladding attachment. Where wood furring is used to attach cladding over foam sheathing, furring minimum fastening requirements to support the cladding weight shall be as specified in Table 2603.11.2. Where placed horizontally, wood furring shall be preservative treated wood in accordance with Section 2303.1.8 or naturally durable wood and fasteners shall be corrosion resistant in accordance Section 2304.9.5.

**TABLE 2603.11.2
FURRING MINIMUM FASTENING REQUIREMENTS FOR APPLICATION
OVER FOAM PLASTIC SHEATHING TO SUPPORT CLADDING WEIGHT^{1,2}**

Furring Material	Framing Member	Fastener Type and Minimum Size	Minimum Penetration into Wall Framing (inches)	Fastener Spacing in Furring (inches)	Maximum Thickness of Foam Sheathing ⁴ (inches)					
					16"oc FURRING ⁵			24"oc FURRING ⁵		
					Cladding Weight:			Cladding Weight:		
					3 psf	11 psf	25 psf	3 psf	11 psf	25 psf
Minimum 1x Wood Furring ³	Minimum 2x Wood Stud	0.120" diameter nail	1-1/4	8	4	4	1.5	4	2	1
				12	4	2	1	4	1.5	0.5
				16	4	2	0.5	4	1	DR
		0.131" diameter nail	1-1/4	8	4	4	2	4	3	1
				12	4	3	1	4	2	0.75
				16	4	2	0.75	4	1.5	DR
	#8 wood screw ⁵	1	12	4	4	1.5	4	3	1	
			16	4	3	1	4	2	0.5	
			24	4	2	0.5	4	1	DR	
	1/4" lag screw ⁵	1-1/2	12	4	4	3	4	4	1.5	
			16	4	4	2	4	3	1	
			24	4	3	1	4	2	0.5	

For SI: 1" = 25.4 mm; 1 pound per square foot (psf) = 0.0479 kPa.

DR = design required

o.c. = on center

- Wood framing and furring shall be Spruce-Pine-Fir or any wood species with a specific gravity of 0.42 or greater in accordance with AFPA/NDS.
- Nail fasteners shall comply with ASTM F1667, except nail length shall be permitted to exceed ASTM F1667 standard lengths.
- Where the required cladding fastener penetration into wood material exceeds 3/4 inch (19.1 mm) and is not more than 1-1/2 inches (38.1 mm), a minimum 2x wood furring shall be used or an approved design.
- Foam sheathing shall have a minimum compressive strength of 15 psi in accordance with ASTM C 578 or ASTM C 1289.
- Furring shall be spaced a maximum of 24 inches (610 mm) on center, in a vertical or horizontal orientation. In a vertical orientation, furring shall be located over wall studs and attached with the required fastener spacing. In a horizontal orientation, the indicated 8 inch (203.2 mm) and 12 inch (304.8 mm) fastener spacing in furring shall be achieved by use of two fasteners into studs at 16 inches (406.4 mm) and 24 inches (610 mm) on center, respectively.

Reason: These siding connection requirements already exist in the New York State Energy Code which is based on the 2009 IECC. Similar requirements for the IECC 2012 were denied last year mainly because it was felt that they belonged in the building code, not the energy code. These requirements fill an information gap in the IBC provisions for exterior wall covering assemblies that include foam plastic insulation. This proposal is coordinated with other proposed changes to Chapter 14 and Chapter 26 to ensure related code provisions are properly linked and addressed. Separate proposals address connection to other wall framing materials.

The proposed requirements are based on a project sponsored by the New York State Energy Research and Development Agency (NYSERDA). The project report is available for download at [http://data.memberclicks.com/site/sfa/NYSERDA_TASK_3_REPORT%20-%20FINAL_\(3-22-10\).pdf](http://data.memberclicks.com/site/sfa/NYSERDA_TASK_3_REPORT%20-%20FINAL_(3-22-10).pdf). The report explains the technical basis for the proposed requirements.

The purpose of the NYSERDA project was to develop prescriptive fastening requirements for cladding materials installed over foam sheathing to ensure adequate performance. The project included testing of cladding attachments through various thicknesses of foam sheathing using various fastener types on steel frame wall assemblies. Supplemental testing also was sponsored by the Foam Sheathing Coalition (lab report available at www.foamshathing.org) to address attachments to wood framing and the resulting data is included in the data set analyzed and presented in the NYSERDA project report. The proposed cladding attachment requirements and foam sheathing thickness limits are based on rational analysis verified by the extensive test data to control cladding connection movement to no more than 0.015" slip under cladding weight or dead load. This deflection controlled

approach resulted in safety factors commonly in the range of 5 to 8 relative to average shear capacity. Similar tests by other independent parties, such as Wiss, Janney, & Elstner (unpublished data) and also Building Science Corporation for DOE's Building America program (report pending) have shown similar results or demonstrate that this proposal has erred to the conservative.

Three separate proposals for wood, steel, and concrete/masonry wall applications have been prepared to ensure that these different applications are considered independently. If one or more of these proposals are approved, the proponent will work with ICC staff to resolve duplicative formatting/numbering of the proposed new code sections.

Cost Impact: The code change proposal will not increase the cost of construction.

FS195-11

Public Hearing:	Committee:	AS	AM	D
	Assembly:	ASF	AMF	DF

2603.11 (NEW) #4-FS-CRANDELL

FS196 – 12

2604.1

Proponent: Tony Crimi, A.C. Consulting Solutions Inc, representing North American Insulation Manufacturers Association (NAIMA) (tcrimi@sympatico.ca)

Revise as follows:

2604.1 General. Plastic materials installed as interior finish or *trim* shall comply with Chapter 8. Foam plastics shall only be installed as interior finish where approved in accordance with the special provisions of Section 2603.10. Foam plastics that are used as interior finish shall also meet the flame spread and smoke developed index requirements for interior finish in accordance with Chapter 8. Foam plastics installed as interior *trim* shall comply with Section 2604.2.

Reason: This proposal is a further clarification and is consistent with previous changes incorporated in the 2012 IBC. In the 2012 IBC, additional language was introduced to 2603.9 to clarify that both the flame spread and smoke developed requirements of Chapter 8 must be complied with for foam plastics that are used as interior finish on the basis of special tests in accordance with 2603.10 of the 2012 IBC.

Section 2603.10 permits foamed plastic insulation to be used as interior wall or ceiling finish in plenums even without the installation of a thermal barrier. Similarly here, the thermal barrier specified in Section 2603.4 is not required under the conditions set forth in Sections 2603.4.1.1 through 2603.4.1.14. Consequently, the smoke developed provisions need to be clearly identified. This would make 2604.1 consistent with 2603.10 in this regard.

Cost Impact: This proposal should not increase the cost of construction.

FS196-12

Public Hearing:	Committee:	AS	AM	D
	Assembly:	ASF	AMF	DF

2604.1-FS-CRIMI

FS197 – 12

2610.2

Proponent: Mike Ennis, representing SPRI Inc. (m.ennis@mac.com)

Delete and substitute as follows:

2610.2 Mounting. The light-transmitting plastic shall be mounted above the plane of the roof on a curb constructed in accordance with the requirements for the type of construction classification, but at least 4 inches (102 mm) above the plane of the roof. ~~Edges of the light-transmitting plastic skylights or domes shall be protected by metal or other approved noncombustible material, or~~ The light transmitting plastic dome or skylight shall be shown to be able to resist ignition where exposed at the edge to a flame from a Class B brand as described in ASTM E 108 or UL 790. The Class B brand test shall be conducted on a skylight that is elevated to a height as specified in the manufacturer's installation instructions, but not less than 4 inches (102 mm).

Exceptions:

1. Curbs shall not be required for skylights used on roofs having a minimum slope of three units vertical in 12 units horizontal (25-percent slope) in occupancies in Group R-3 and on buildings with a nonclassified roof covering.
2. ~~The metal or noncombustible edge material~~ Class B brand testing as described in ASTM E 108 or UL 790 is not required where nonclassified roof coverings are permitted.

Reason: The flames of the Class B brand can extend above the noncombustible edge and contact the dome, allowing for the possibility of catching fire and test failure. ASTM E108 tests have been conducted on products with non-combustible edge material in which the flame extended beyond the noncombustible edge material resulting in ignition and burning of the plastic dome. To evaluate plastic dome skylights for fire resistance testing per ASTM E108 or UL790 with a Class B brand should be the base requirement. Skylights having non-combustible edges should not be exempted from the fire testing.

The video file showing the ASTM E108 or UL790 Class B brand test being conducted on a plastic dome skylight, with the minimum allowable edge height of 4-inches is too large to be sent with the proposal. It can be viewed at the following link: <http://www.spri.org/publications/policy.htm>. The video is located at the bottom of the page under Miscellaneous. The edge material in this video is noncombustible.

Cost Impact: This code change proposal will not increase the cost of construction, however it will increase the cost associated with plastic domed skylights meeting requirements of the IBC.

FS197-12

Public Hearing:	Committee:	AS	AM	D
	Assembly:	ASF	AMF	DF

2610.2-FS-ENNIS

FS198 – 12

202, 1410 (New), 2601, 2602, 2612 (New), Chapter 35

Proponent: Marcelo M Hirschler, GBH International (gbhint@aol.com)

THIS CODE CHANGE WILL BE HEARD BY THE IBC STRUCTURAL COMMITTEE. SEE THE TENTATIVE HEARING ORDER FOR THIS COMMITTEE.

Revise as follows:

SECTION 202 DEFINITIONS

PLASTIC COMPOSITE. A generic designation that refers to wood/plastic composites and plastic lumber.

PLASTIC LUMBER. A manufactured product made primarily of plastic materials (filled or unfilled) which is generally rectangular in cross-section and is typically supplied in sizes that correspond to traditional lumber board and dimensional lumber sizes.

WOOD/PLASTIC COMPOSITE. A composite material made primarily from wood or cellulose-based materials and plastic.

Add new text as follows:

SECTION 1410 PLASTIC COMPOSITE DECKING

1410.1 Exterior deck boards, stair treads, handrails and guardrail systems constructed of plastic composites, including plastic lumber, shall comply with Section 2612.

Revise as follows:

SECTION 2601 GENERAL

2601.1 Scope. These provisions shall govern the materials, design, application, construction and installation of foam plastic, foam plastic insulation, plastic veneer, interior plastic finish and trim, ~~and~~ light-transmitting plastics, and plastic composites, including plastic lumber. See Chapter 14 for requirements for exterior wall finish and trim.

SECTION 2602 DEFINITIONS

2602.1 General. The following words and terms shall, for the purposes of this chapter and as used elsewhere in this code, have the meanings shown herein.

FIBER-REINFORCED POLYMER
FOAM PLASTIC INSULATION
LIGHT-DIFFUSING SYSTEM
LIGHT-TRANSMITTING PLASTIC ROOF PANELS
LIGHT-TRANSMITTING PLASTIC WALL PANELS
PLASTIC, APPROVED
PLASTIC COMPOSITE
PLASTIC GLAZING
PLASTIC LUMBER
THERMOPLASTIC MATERIAL

THERMOSETTING MATERIAL
WOOD/PLASTIC COMPOSITE

SECTION 2612
PLASTIC COMPOSITES

2612.1 General. Plastic composites shall consist either of wood/plastic composites or of plastic lumber. Plastic composites shall comply with the provisions of this code and with the additional requirements of Section 2612.

2612.2 Labeling and identification. Packages and containers of plastic composites used in exterior applications delivered to the job site shall bear the *label* of an *approved agency* showing the manufacturer's name, product listing, product identification and information sufficient to determine that the end use will comply with the code requirements.

2612.2.1 Performance levels. The label for plastic composites used in exterior applications as deck boards, stair treads, handrails and guardrail systems shall indicate the required performance levels and demonstrate compliance with the provisions of ASTM D7032. If the plastic composites are plastic lumber materials, the label shall additionally indicate compliance with the provisions of ASTM D6662.

2612.2.2 Loading. The label for plastic composites used in exterior applications as deck boards, stair treads, handrails and guardrail systems shall indicate the type and magnitude of the load determined in accordance with ASTM D7032 or with ASTM D6662, as appropriate.

2612.3 Flame Spread Index. Plastic composites required elsewhere in this code to comply with fire safety requirements, including a flame spread index, shall have those properties determined in accordance with Chapter 8. Otherwise, wood/plastic composite materials shall meet the requirements of ASTM D7032 and plastic lumber materials shall meet the requirements of ASTM D6662.

Exception: materials determined to be noncombustible in accordance with Section 703.5.

2612.4 Termite and Decay resistance. Plastic composites containing wood, cellulosic or any other biodegradable materials shall be termite and decay resistant as determined in accordance with Section 4.8 of ASTM D7032.

2612.5 Construction requirements. Plastic composites shall be permitted to be used as structural components of exterior deck boards, stair treads, handrails and guardrail systems in buildings of Class VB construction. Plastic composite decking shall also comply with the requirements of Section 2612.6.

2612.5.1 Span rating. Plastic composites used as structural components of exterior deck boards shall have a span rating determined in accordance with ASTM D7032 with a deflection limit of L/360.

2612.5.2 Differential movement of components. Plastic composites used as structural elements of exterior deck boards shall have approved fastening to allow for differential movement of the structural members to which the materials are fastened.

2612.5.3 Handrails and Guards. Plastic composites used in handrail systems shall comply with the requirements of Section 1012. Plastic composites used in guardrail systems shall comply with the requirements of Section 1013.

2612.6 Plastic composite decking. Plastic composite decking shall be designed and installed in accordance with the general provisions of this code and Sections 2612.6.1 through 2612.6.2.

2612.6.1 General. Each piece of decking composed of plastic composites shall be square-end trimmed. When random lengths are furnished, each piece shall be square end trimmed across the face so that at least 90 percent of the pieces are within 0.5 degrees (0.00873 rad) of square. The ends of the pieces

shall be permitted to be beveled up to 2 degrees (0.0349 rad) from the vertical with the exposed face of the piece slightly longer than the opposite face of the piece. Tongue-and groove decking shall be installed with the tongues up on sloped or pitched roofs with pattern faces down.

2612.6.2 Layup patterns. Decking composed of plastic composites is permitted to be laid up following one of five standard patterns as defined in Sections 2304.8.2.1 through 2304.8.2.5 for lumber decking. Other patterns are permitted to be used provided they are substantiated through engineering analysis.

Add new standards as follows:

CHAPTER 35 REFERENCED STANDARDS

ASTM D6662, Standard Specification for Polyolefin-Based Plastic Lumber Decking Boards
ASTM D7032, Standard Specification for Establishing Performance Ratings for Wood-Plastic Composite Deck Boards and Guardrail Systems (Guards or Handrails)

Reason: This proposal recommends permitting the use of plastic composites for exterior applications as deck boards, stair treads, handrails and guardrail systems in buildings of Class VB construction. Since these materials contain significant amounts of plastic components, they are probably best included in a new separate section of Chapter 26. The requirements shown mirror those of wood decks/lumber decking.

Plastic composites can be plastic lumber or wood plastic composites. Both types of products are made of plastic materials with added fibrous materials to provide stiffness. There are some differences between the two, but they are relatively subtle. Wood plastic composites contain wood materials, or cellulosic materials, (normally over 50%) as the primary fiber that provides the stiffness. On the other hand plastic lumber materials contain primarily plastic (normally over 50%) and use a variety of materials to provide stiffness, often fiberglass. Specifications have been issued by ASTM for both types of plastic composite; the materials (and the specifications) fall under the jurisdiction of different technical committees. Committee D07 (on wood) issued ASTM D7032, Standard Specification for Establishing Performance Ratings for Wood-Plastic Composite Deck Boards and Guardrail Systems (Guards or Handrails), presently referenced both in the IRC and in the IWUIC. Committee D20 (on plastics) issued ASTM D6662, Standard Specification for Polyolefin-Based Plastic Lumber Decking Boards, presently referenced in the IWUIC.

Numerous plastic lumber decks are used throughout the US, but neither the IRC nor the IBC reference them. The IBC also does not reference wood plastic composite decks, and the requirements are similar. The ICC Evaluation Services recognizes both types of materials under Acceptance Criteria AC 174, Acceptance Criteria for Deck Board Span Ratings and Guardrail Systems (Guards and Handrails). It is suitable to incorporate these materials into the IBC in a separate section under Chapter 26 (plastics) and permit them to be used for decks in Class VB construction.

Specification ASTM D6662, for plastic lumber decking boards, requires the plastic lumber to comply with properties based on the following ASTM standards:

ASTM D2565 Standard Practice for Xenon-Arc Exposure of Plastics Intended for Outdoor Applications

ASTM D2915 Standard Practice for Evaluating Allowable Properties for Grades of Structural Lumber

ASTM D4329 Standard Practice for Fluorescent UV Exposure of Plastics

ASTM D6109 Standard Test Methods for Flexural Properties of Unreinforced and Reinforced Plastic Lumber and Related Products

ASTM D6341 Standard Test Method for Determination of the Linear Coefficient of Thermal Expansion of Plastic Lumber and Plastic Lumber Shapes Between -30 and 140°F [-34.4 and 60°C]

ASTM E84 Standard Test Method for Surface Burning Characteristics of Building Materials

ASTM G151 Standard Practice for Exposing Nonmetallic Materials in Accelerated Test Devices that Use Laboratory Light Sources

ASTM G154 Standard Practice for Operating Fluorescent Light Apparatus for UV Exposure of Nonmetallic Materials

ASTM G155 Standard Practice for Operating Xenon Arc Light Apparatus for Exposure of Non-Metallic Materials

Specification ASTM D7032 requires the material to comply with many of the same properties. They include flexural properties (ASTM D6109), Xenon-arc exposure (ASTM D2565), structural lumber grade classifications (ASTM D2915). In fact, it requires UV resistance in accordance with ASTM D6662.

Specification ASTM D7032 also requires the material to comply with biodeterioration tests (decay, fungi and termite resistance) if the material contains wood, cellulosic or other biodegradable materials (section 4.8). Resistance to termites is assessed via ASTM D3345 or AWPA E1 and resistance to fungal decay in accordance with ASTM D1413, ASTM D2017 or AWPA E10. This is included in the code proposal for plastic composite materials.

With regard to fire properties, ASTM D6662 requires that plastic lumber meet ASTM E84, Steiner tunnel test, with a flame spread index of no more than 200, with a material that is required to remain in place during the test. The wording with regard to ASTM E84 flame spread testing in ASTM D6662 is very explicit, and much clearer than the wording in the test method itself. The requirements in ASTM D6662 ensure that no material "passes" the ASTM E84 test while falling to the tunnel floor before the flame progresses that far. The following wording is included in the ASTM D6662 standard:

"6.4.2 The test specimen shall either be self-supporting by its own structural characteristics or held in place by added supports along the test specimen surface. The test specimen shall remain in place throughout the test duration, without such severe sagging that it interferes with the effect of the gas flame on the test specimen. Test results are invalid if the bulk of the test specimen melts or drops to the furnace floor."

ASTM D7032 also requires wood-plastic composite decking materials to comply with a flame spread index of no more than 200 when tested to ASTM E84. However, ASTM D7032 does not have the additional requirements that the material stay in place. It also allows (as does AC 174) the use of alternate fire test methods for assessing fire performance of the wood plastic composite materials.

This proposal requires that wood plastic composite materials comply with the requirements of ASTM D7032 and that plastic lumber materials comply with the requirements of both ASTM D6662 and ASTM D7032, thereby including in the code all physical and mechanical property and fire test requirements associated with both types of decking materials. It is not clear whether wood plastic composite materials are always capable of complying with all the requirements of ASTM D6662, including the fire test.

Just for information: wood materials normally comply with a flame spread index of no more than 200.

Structural plastic lumber materials exhibit long lasting, weather resistance together with the structural characteristics of dimensional wood lumber. The materials are made primarily from recycled plastics from post-consumer waste like plastic milk and detergent bottles. The materials then include strengthening additives, UV-inhibited pigments, anti-oxidant processing aids and foaming agents for a highly stable material that is at least equivalent to wood lumber in some measures.

For information, the fire test required by AC 174 is optional, as it states that it requires a "flame spread rating ... determined by testing in accordance with section 4.9 of ASTM D7032". The complete section of AC 174 reads as follows:

"The flame-spread rating of materials used to fabricate deck boards and components of guardrail systems (guards and handrails) shall be determined by testing in accordance with Section 4.9 of ASTM D 7032. Alternatively, any other approved test procedure is permitted to be used for determining a flame-spread rating of the materials that will give comparable results to tests conducted in accordance with ASTM E 84."

ASTM D7032 states as follows:

"4.9 *Fire Performance Tests* — The flame-spread rating of materials used to fabricate deck boards, guards, and handrails shall be determined by testing in accordance with Test Method E 84.

4.9.1 *Criterion*—Materials shall have a flame-spread index no greater than 200 when tested in accordance with Test Method E 84.

NOTE 5 — Other test procedures may be permitted for determining a flame-spread rating for the material. Depending upon material formulation, other fire performance tests may be required. Additionally, fire performance properties other than flame spread may be important. Test Methods E 1354 or D 1929, or procedures in Annex A2 may be used to provide an assessment of one or more of the following properties: smoke release rate, mass loss rate, heat release rate, ignition temperatures, and spread of flame. "

A few photographs of some actual plastic lumber decks follow.





Cost Impact: None

Analysis: A review of the standard proposed for inclusion in the code, ASTM D7032 with regard to the ICC criteria for referenced standards (Section 3.6 of CP#28) will be posted on the ICC website on or before April 2, 2012.

FS198-12

Public Hearing:	Committee:	AS	AM	D
	Assembly:	ASF	AMF	DF

202-PLASTIC COMPOSITE (NEW)-G-HIRSCHLER

FS199 – 12

202, 720.2.1, 2614 (New)

Proponent: Ken Sagan, NRG Code Advocates, representing Reflective Insulation Manufacturers Association International (KEN@NRGCODEADVOCATES.COM)

Add new definition as follows:

Radiant Barrier. A material having a low emittance surface (0.1 or less) and when installed in building assemblies, the low emittance surface shall face a ventilated or unventilated air space.

Revise as follows:

720.2.1 Facings. Where such materials are installed in concealed spaces in buildings of Type III, IV or V construction, the flame spread and smoke-developed limitations do not apply to facings, coverings, and layers of reflective foil insulation that are installed behind and in substantial contact with the unexposed surface of the ceiling, wall or floor finish.

Exceptions:

1. All layers of single and multilayer reflective plastic core insulation shall comply with Section 2613.
2. All radiant barrier with plastic core shall comply with Section 2614.

Add new text as follows:

SECTION 2614 **RADIANT BARRIER with PLASTIC CORE**

2614.1 General. The provisions of this section shall govern the requirements and uses of radiant barrier with plastic core in buildings and structures. Radiant barrier with plastic core shall comply with the requirements of Section 2614.2 and with Section 2614.3 or 2614.4.

2614.2 Identification. Packages and containers of radiant barrier with plastic core delivered to the job site shall show the manufacturers or supplier's name, product identification and information sufficient to determine that the end use will comply with code requirements.

2613.3 Surface-burning characteristics. Radiant barrier with plastic core shall have a flame spread index of not more than 25 and a smoke-developed index of not more than 450 when tested in accordance with ASTM E84 or UL 723. The radiant barrier with plastic core shall be tested at the maximum thickness intended for use. Test specimen preparation and mounting shall be in accordance with ASTM E2599.

Exception: Does not apply to radiant barrier applied to structural sheathing.

2613.4 Room corner test heat release. Radiant barrier with plastic core shall comply with the acceptance criteria of Section 803.1.2.1 when tested in accordance with NFPA 286 or UL 1715 in the manner intended for use and at the maximum thickness intended for use.

Exception: Does not apply to radiant barrier applied to structural sheathing.

Reason: Product design innovations have resulted in a radiant barrier product configuration that requires the same treatment as *reflective plastic core insulation* as it pertains to flame/smoke safety. This proposal will require the same flame/smoke requirements for radiant barriers to be the same established by UL 723 or ASTM E84 as documented in Section 2613.3.

This proposal is intended to establish a new section on radiant barriers without the confusion as to whether the material is a radiant barrier or an insulator. The sections in chapter 26 address different types of plastic. In order to be consistent with the previous actions in this chapter, this proposal adds another plastic based product used in the construction industry that will be

defined and approved for use. Product design innovations have resulted in a radiant barrier product configuration that requires the same treatment as reflective plastic core insulation as it pertains to flame/smoke safety – these products also contain plastic cores. As far back as the 1970s, sheets of metalized polyester called space blankets have been commercially available as a means to prevent hypothermia and other cold weather injuries. Because of their durability and light weight, these blankets are popular for survival and first aid applications. Swarms of people can be seen draped in reflective metalized film after a marathon, especially where the temperatures are particularly cold, like during the annual ING New York City marathon which takes place in the fall. In other words, aluminum is a good heat reflector and a bad heat radiator.

Radiant Barrier Systems (RBS) is a mature energy-saving technology having first been evaluated in the late 1950s (Joy, 1958).

Aluminum foil or metalized films, are the operative materials in many radiant barrier products. They have two physical properties of interest. First, they reflect thermal radiation very well. Second, they emit (gives off) very little heat. Most innovations now are materials related. For instance, industry has recently begun to manufacture roof plywood decking with a radiant barrier already adhered to its underside. Although reducing labor costs for new construction, it has little application to a retrofit technology. Probably the greatest potential for performance enhancement comes from proper installation. Proper installation of radiant barrier systems are covered in design notes from Florida Solar Energy Center (Fairey, 1984) and from ASTM standard C-1158.

Radiant Barriers can be incorporated into window treatments, roofs and attics, and walls. Wrapping a house with radiant barrier can result in a 10% to 20% reduction in the tonnage of air conditioning system requirement, and save both energy and construction costs.

Ingrid Melody and her publication: Radiant Barriers: A Question and Answer Primer address the proper use and applications of radiant barriers, the energy savings and case studies where radiant barriers have been evaluated.

<http://www.fsec.ucf.edu/en/publications/html/fsec-en-15/>

Results from a recent comprehensive field monitoring study conducted for Florida Power Corporation (FPC) by FSEC on the performance of attic radiant barrier systems in central Florida homes may be viewed by reading "FPC Residential Monitoring Project: New Technology Development - Radiant Barrier Pilot Project".

<http://www.fsec.ucf.edu/en/publications/pdf/FSEC-DN-6-86.pdf>

<http://www.fsec.ucf.edu/en/publications/pdf/FSEC-DN-7-84.pdf>

Additional Reference material by Florida Solar Energy Center:

References:

ASTM C1313/C1313M-10 Standard Specification for Sheet Radiant Barriers for Building Construction Applications
 C1744-10 Practice for Installation and Use of Radiant Barrier Systems (RBS) in Commercial/Industrial Building Construction

Selected References:

Danny S. Parker, Jeffrey K. Sonne, John R. Sherwin "Flexible Roofing Facility: 2002 Summer Test Results", Prepared for: U.S. Department of Energy Building Technologies Program, July 2003

Parker, D., Sherwin, J., "Comparative Summer Attic Thermal Performance of Six Roof Contructions," The 1998 ASHRAE Annual Meeting, Toronto, Canada, June 20-24, 1998.

Parker, D., Sherwin, J., Sonne, J., Barkaszi, S., Floyd, D., Withers, C., "Measured Energy Savings of a Comprehensive Retrofit in an Existing Florida Residence," For the Florida Energy Office, December, 1997

Fairey, P., "Designing and Installing Radiant Barrier Systems," FSEC-DN-7, Florida Solar Energy Center, Cape Canaveral, FL, 1984.

Fairey, P., "Effects of Infrared Radiation Barriers on the Effective Thermal Resistance of Building Envelopes," proceedings of the ASHRAE/DOE Conference on Thermal Performance of the Exterior Envelopes of Buildings II, Las Vegas, NV, December 1982.

Fairey, P., "The Measured Side-by-Side Performance of Attic Radiant Barrier Systems in Hot-Humid Climates," proceedings of the 19th International Thermal Conductivity Conference, Cookeville, TN, October 1985.

Fairey, P., "Radiant Energy Transfer and Radiant Barrier Systems in Buildings," FSEC-DN-6, Florida Solar Energy Center, Cape Canaveral, FL, 1984.

Joy, F.A., "Improving Attic Space Insulating Values," **ASHAE Transactions**, Vol.64, 1958.

"Radiant Barriers: How They Work and How to Install Them," videotape, FSEC Producer, Cape Canaveral, FL, 1986.

Van Stratten, J.F., **Thermal Performance of Buildings**, New York: Elsevier Publishing, 1967.

Cost Impact: The code change proposal will not increase the cost of construction.

FS199-12

Public Hearing:	Committee:	AS	AM	D
	Assembly:	ASF	AMF	DF

720.1-FS-SAGAN-2614 (NEW)-FS-SAGAN

FS200 – 12

Appendix L (New), Chapter 35

Proponent: Stephen V. Skalko, representing Portland Cement Association; Eric T. Stafford, representing Institute for Business and Home Safety; Jason Thompson, National Concrete Masonry Association, representing Masonry Alliance for Codes and Standards

Add new text as follows:

APPENDIX L **BUILDING RESILIENCE**

The provisions in this appendix are not mandatory unless specifically referenced in the adopting ordinance.

SECTION L101 **GENERAL**

L101.1 Purpose. The purpose of this appendix is to promote enhanced public health, safety and general welfare and to reduce public and private property losses due to hazards and natural disasters associated with fires, flooding, high winds and earthquakes.

SECTION L102 **EXTERIOR WALLS**

L102. 1 General. In addition to the requirements for Exterior Walls in Chapter 14 of the *International Building Code*, the exterior wall coverings shall also comply with Sections L102.2 through L102.4.

L102.2 Exterior wall covering limitations for reduced damage from fire. Exterior wall coverings shall comply with L102.2.1 and L102.2.2 to reduce damage from fire exposure

L102.2.1 Vinyl siding and Exterior insulation and finish systems (EIFS). Vinyl siding conforming to the requirements of Chapter 14 of the *International Building Code* and Exterior insulation and finish systems (EIFS) conforming to the requirements of Chapters 14 and 26 of the *International Building Code* shall only be permitted to be installed on exterior walls of buildings with a minimum fire separation distance of 30 feet.

L102.2.2 Fire Separation 5 Feet or Less. Combustible exterior wall coverings are not permitted on exterior walls having a fire separation distance or 5 feet (1524 mm) or less.

L102.3 Exterior wall covering limitations for reduced damage from hail. Vinyl siding conforming to the requirements of Chapter 14 of the *International Building Code* and Exterior insulation and finish systems (EIFS) conforming to the requirements of Chapters 14 and 26 of the *International Building Code* shall comply with sections L102.3.1 and L102.3.2.

L102.3.1 Hail Exposure regions. Hail exposure regions in Figure L102.3 shall be as follows:

- (a) Moderate** - One or more hail days with hail diameters greater than 1.5 in (38 mm) in a twenty (20) year period.
- (b) Severe** - One or more hail days with hail diameters greater than 2.0 in (50 mm) in a twenty (20) year period.

L102.3.2 Exterior wall coverings subject to hail exposure. Wall coverings used in regions where hail exposure is Moderate or Severe, as determined in accordance with Section L102.3.1 and Figure L102.3, shall be tested, classified, and labeled in accordance with UL 2218 or FM 4473.

L102.4 Exterior wall covering limitations for reduced damage from wind. Vinyl siding and Exterior insulation and finish systems (EIFS) conforming to the requirements of Chapter 14 of the *International Building Code* shall only be permitted to be installed on exterior walls of buildings located outside hurricane-prone regions as defined in Section 1609.2.

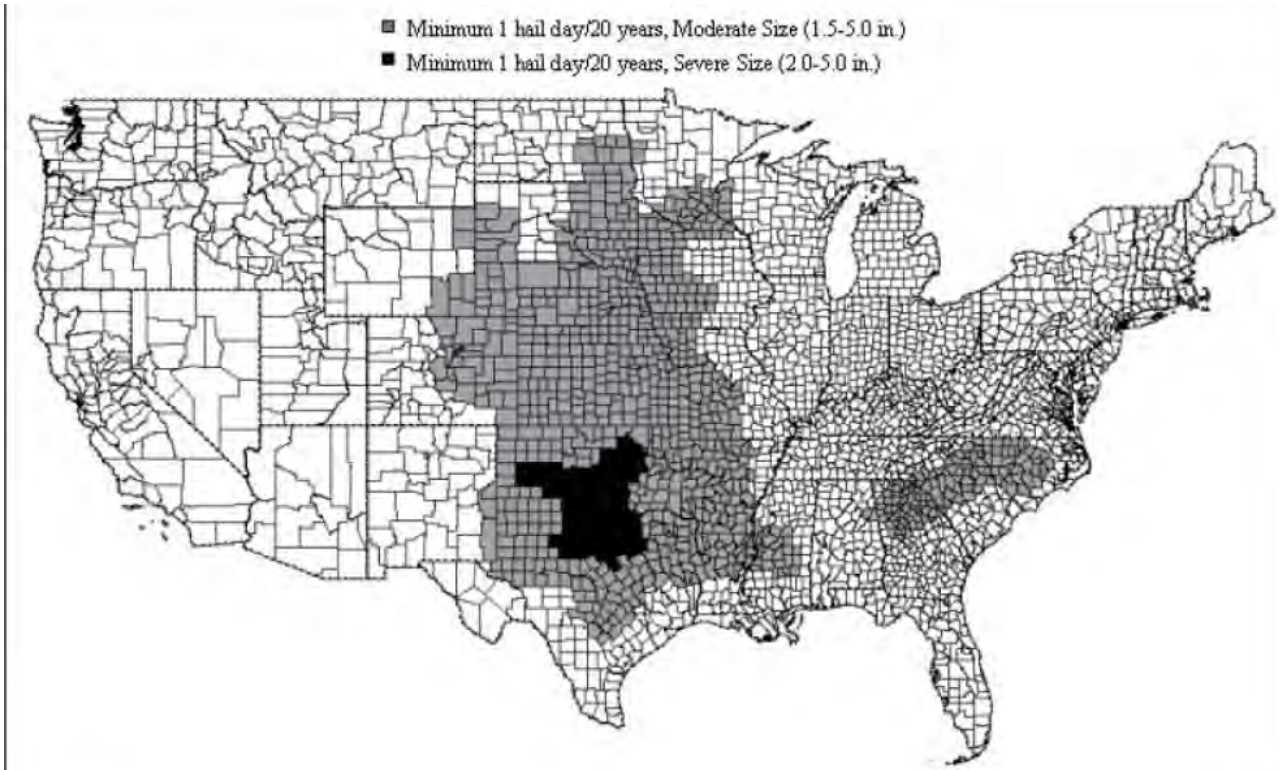

FIGURE L102.3

SECTION L103
ROOF ASSEMBLIES

L103.1 General. In addition to the requirements for Roof Assemblies and Rooftop Structures in Chapter 15 of the *International Building Code*, the roof coverings shall also comply with Sections with Sections L103.2 through L103.4.

L103.2 Non-classified roofs. Non-classified roof coverings in accordance with Section 1505.5 of the *International Building Code* shall not be permitted on *buildings*.

L103.3 Roofs in Warm and Dry Climates. Roofs in climate zones 1, 2, 3, 4, 5B (dry), and 6B (dry) of the *International Energy Conservation Code (IECC)* shall have a Class A roof covering or Class A roof assembly according to UL 790. For roof coverings where the profile allows a space between the roof covering and roof decking, the space at the eave ends shall be firestopped to preclude entry of flames or embers.

L103.4 Roof coverings subject to hail exposure. Roof coverings used in regions where hail exposure is Moderate or Severe, as determined in accordance with Section L103.4.1 and Figure L102.3, shall be tested, classified, and labeled in accordance with UL 2218 or FM 4473.

L103.4.1 Hail Exposure regions in Figure L102.3 shall be as follows:

- (a) **Moderate** - One or more hail days with hail diameters greater than 1.5 in (38 mm) in a twenty (20) year period.
- (b) **Severe** - One or more hail days with hail diameters greater than 2.0 in (50 mm) in a twenty (20) year period.

Add standards to Chapter 35 as follows:

UL 2218-10 *Impact Resistance of Prepared Roof Covering Materials*. UL 2218, *Impact Resistance of Prepared Roof Covering Materials*.

FM 4473-11 *Specification Test Standard for Impact Resistance Testing of Rigid Roof Materials by Impacting With Freezer Ice Balls*.

Reason: This reason statement has the following two segments to explain the reasons for this change: (A) The code change is explained with specific substantiation; and (B) General background information identifying the need for enhanced property protection and functional resilience for to strengthen the built environment;

(A)

The following are reports of dollar loss to property from wind, cold weather and fire disasters.

- The American Society of Civil Engineers reported in *Normalized Hurricane Damage in the United States, 1900 – 2005*, National Hazard Review, ASCE 2008, that property damage from hurricanes was 81 billion dollars in 2005.
- The National Weather Service reports that U.S. property damage due to winter storms and ice exceeded 1.5 billion dollars in 2009.
- *Fire Losses in the United States During 2009* by the National Fire Protection Association, August 2010 shows that property loss due to structure fires in buildings other than one and two family dwellings was approximately 4.5 billion dollars.

Increasing the stringency of the design criteria of buildings for hazards such as wind, snow or fire results in more robust buildings. Such requirements reduce the amount of energy and resources required for repair, removal, disposal and replacement of building components and systems damaged from these disasters. A further benefit is a reduction in the amount of damaged building materials and content entering landfills.

Additional benefits are enhanced life safety, security and occupant comfort; potentially less demand on community resources required for emergency response; and allowing facilities to be more readily adapted for re-use if there is a change of occupancy in the future.

(B)

Minimum building requirements whether through energy codes, plumbing codes, mechanical codes, zoning codes, or basic building codes, do not encourage truly sustainable buildings. The proposal is one of several that attempt to integrate the concepts of the *Whole Building Design Guide* (WBDG) into the International Building Code as a non-mandatory Appendix. This allows adopting jurisdictions the option of incorporating code requirements into the building code to improve the resilience of the built environment without the need to add another code to the community requirements.

The WBDG, developed in partnership between the National Institute of Building Sciences (NIBS) and the Sustainable Building Industries Council (SBIC), has as its key concepts: accessible, aesthetics, cost-effective, functional/operational, historic preservation, productive, secure/safe, and sustainable.

There are numerous references about the economic, societal, and environmental benefits that result when enhanced functional resilience for resource minimization are integrated into building design and construction. Six examples demonstrating the importance and supporting the concepts are:

1. ***Natural Hazard Mitigation Saves: An Independent Study to Assess the Future Savings from Mitigation Activities***
National Institute of Building Sciences Multi-Hazard Mitigation Council - 2005
One of the findings in this report is "The analysis of the statistically representative sample of FEMA grants awarded during the study period indicates that a dollar spent on disaster mitigation saves society an average of \$4." The programs studied often addressed issues and strategies other than enhanced disaster resistance of buildings and other structures. However, more disaster-resistant buildings enhance life safety; reduce costs and environmental impacts associated with repair, removal, disposal, and replacement; and reduce the time and resources required for community recovery.
2. ***Five Years Later – Are we better prepared?***
Institute for Business and Home Safety - 2010
This IBHS report states: "When Hurricane Katrina made landfall on Aug. 29, 2005, it caused an estimated \$41.1 billion in insured losses across six states, and took an incalculable economic and social toll on many communities. Five years later, the

recovery continues and some residents in the most severely affected states of Alabama, Louisiana and Mississippi are still struggling. There is no question that no one wants a repeat performance of this devastating event that left at least 1,300 people dead. Yet, the steps taken to improve the quality of the building stock, whether through rebuilding or new construction, call into question the commitment of some key stakeholders to ensuring that past mistakes are not repeated." This report indicates that there is a need to implement provisions to make buildings more disaster-resistant. Clearly this suggests that functional resilience should at least be integrated into the design and construction of sustainable buildings.

3. National Weather Service Office of Climate, Water and Weather Services

National Oceanic and Atmospheric Administration (NOAA) - 2010

Data provided on the NOAA website [www.weather.gov/os/hazstats.shtml] indicates that the average annual direct property loss due to natural disasters in the United States exceeds of \$35,000,000,000. This does not include indirect costs associated with loss of residences, business closures, and resources expended for emergency response and management. These direct property losses also do not reflect the direct environmental impact due to reconstruction after the disasters. Functional resilience will help alleviate the environmental impact and minimize both direct and indirect losses from natural disasters.

4. Global Climate Change Impacts in the United States

U.S. Global Change Research Program (USGCRP) - 2009

The USGCRP includes the departments of Agriculture, Commerce, Defense, Energy, Health and Human Services, Interior, State and Transportation; National Aeronautic and Space Administration; Environmental Protection Agency, USA International Development, National Science Foundation and Smithsonian Institution

The report identifies that: "Climate changes are underway in the United States and are projected to grow. Climate-related changes are already observed in the United States and its coastal waters. These include increases in heavy downpours, rising temperature and sea level, rapidly retreating glaciers, thawing permafrost, lengthening growing seasons, lengthening ice-free seasons in the ocean and on lakes and rivers, earlier snowmelt, and alterations in river flows. These changes are projected to grow." The report further identifies that the: "Threats to human health will increase. Health impacts of climate change are related to heat stress, waterborne diseases, poor air quality, extreme weather events, and diseases transmitted by insects and rodents. Robust public health infrastructure can reduce the potential for negative impacts." Key messages in the report on societal impacts include:

- "City residents and city infrastructure have unique vulnerabilities to climate change. "
- "Climate change affects communities through changes in climate-sensitive resources that occur both locally and at great distances."
- "Insurance is one of the industries particularly vulnerable to increasing extreme weather events such as severe storms, but it can also help society manage the risks."

Sustainable building design and construction cannot be about protecting the natural environment without consideration of the projected growth in severe weather. Minimum codes primarily based on past natural events are not appropriate for truly sustainable buildings. Buildings expected to have long term positive impacts on the environment must be protected from these extreme changes in the natural environment. The provisions for improved property protections are necessary to reduce the amount of energy and resources associated with repair, removal, disposal, and replacement due to routine maintenance and damage from disasters. Further such provisions reduce the time and resources required for community disaster recovery.

5. Sustainable Stewardship - Historic preservation plays an essential role in fighting climate change ,

Traditional Building, National Trust for Historic Preservation - 2008

In the article Richard Moe summarizes the results of a study by the Brookings Institution which projects that by 2030 we will have demolished and replaced 82 billion square feet of our current building stock, or nearly 1/3 of our existing buildings, largely because the vast majority of them weren't designed and built to last any longer. Durability, as a component of functional resilience, can reduce these losses.

6. Opportunities for Integrating Disaster Mitigation and Energy Retrofit Programs

Senate Environment and Public Works Committee Room, Dirksen Senate Office Building, Washington, D.C. - 2010

During this panel discussion a representative of the National Conference of State Historic Preservation Officers noted that more robust buildings erected prior to 1950 tend to be more adaptable for reuse and renovation. Prior to the mid-1950s most local jurisdictions developed their own building code requirements that uniquely addressed the community's needs, issues and concerns. Pre-1950 building codes typically resulted in more durable and robust construction that lasts longer.

The total environmental impact of insulation, high efficiency equipment, components, and appliances, low-flow plumbing fixtures, and other building materials and contents are relatively insignificant when rendered irreparable or contaminated and must be disposed of in landfills after disasters. The US Army Corps of Engineers estimated that after Hurricane Katrina nearly 1.2 billion cubic feet of building materials and contents ended up in landfills. This is analogous to stacking enough refrigerators a fifth of the way to the moon or placing them end to end around the equator of the Earth twice.

Cost Impact: This proposal may increase the cost of construction

Analysis: A review of the standard proposed for inclusion in the code, UL 2218-10 and FM 4473-11, with regard to the ICC criteria for referenced standards (Section 3.6 of CP#28) will be posted on the ICC website on or before April 2, 2012.

FS200-12

Public Hearing:	Committee:	AS	AM	D
	Assembly:	ASF	AMF	DF

