



**ICC A117.1 STANDARD**  
**FOURTH PUBLIC REVIEW DRAFT**  
**SUPPLEMENT**

**August 25, 2016**

**ICC/ANSI A117.1 STANDARD**  
**DEVELOPMENT - 2015 EDITION**

**A117.1 Standard Committee**  
**2012 Cycle Changes to review for**  
**2015 Edition of the A117.1 Standard**  
Copyright ©2016 International Code Council, Inc.

## ICC A117.1 Standard – Accessible and Usable Buildings and Facilities Fourth Public Review Draft - Supplement

This document is an informational companion to the Fourth Public Review Draft of the 2015 edition of the ICC A117.1 Standard. The intent of the Supplement is to show the approved changes in context with the balance of the standard. The Fourth Public Review Draft – Supplement is an unofficial merging of the approved changes into the Standard as reflected in the First through Fourth Public Review Drafts. Where there are multiple changes to one section, they are shown merged as would eventually occur in the final standard when published.

### Font color:

1. Text shown in the **blue font** reflects changes approved by the A117.1 Committee that were included in the First, Second and Third Public Review Drafts. Where text is completely removed versus revised, such text is shown ~~crossed-out~~. Otherwise the text is shown without underlines or crossouts.
2. Text shown in **green font** reflects changes approved by the Committee and are the changes of the Fourth Public Review Draft. These changes are shown in a legislative format. (Text being removed is ~~crossed-out~~; text being added is underlined.) Public Comments can be submitted on the Fourth Public Review Draft – see that document.
3. Text shown in **red font** reflects editorial revisions.

**Figures:** This is a working document provided for information purposes. For the first time we have included many ‘working’ figures being developed for the 2015 edition. Such figures are not technically part of the standard, but interpretation of the text of the standard. They are essentially editorial. If you wish to make suggestions on these working figures; or suggest other locations where you feel a figure would be helpful, please send an email direction to Kermit Robinson @ [krobinson@iccsafe.org](mailto:krobinson@iccsafe.org).

For further information please see the following documents. The documents are found the A117.1 Standard page of the ICC website. <http://www.iccsafe.org/icc-asc-a117/>

1. Fourth Public Review Draft
2. Fourth Public Review Draft- Background report
3. Third Public Review Draft – Background Report
4. Second Public Review Draft – Background Report
5. First Public Review Draft - Background Report.

**Proposal Numbers:** Each change is based on one of the original set of proposals considered by the committee in 2012. The proposal number, for example (9-7-12), is placed after the text created by the proposal. Public comments on those original changes will be followed by PC designation, for example (9-7-12 PC2) or (9-7.12 PC2.1). To find information in the related background reports, use the proposal number and public comment numbers to find the relevant information.

### **Providing Public Comment.**

Comments on the Fourth Public Review draft will be accepted through Tuesday, October 11, 2016. Comments on the review draft must be provided on the ICC Standards Public Comment Form. The form can be found at the ICC website as follows: <http://www.iccsafe.org/standards-public-forms/>

Comments will only be accepted on the changes shown in the Fourth Public Review Draft. Public comments on this Supplemental document are limited to the working figures. Comments on the figures do not need to be on the form, just send an email to address below. For further information regarding submitting comments, please see the Fourth Public Review Draft document.

If you have questions, please direct them to Kermit Robinson, [krobinson@iccsafe.org](mailto:krobinson@iccsafe.org)

**Closing Date for Public Comments on the Third Public Review Draft: Tuesday, October 11, 2016**

# Chapter 1. Application and Administration

## 101 Title

This document shall be known as *Accessible and Usable Buildings and Facilities*, hereinafter referred to as 'this standard'. (1-1-12)

## 102 Purpose

The technical criteria in Chapters 3 through 10, Sections 1102, 1103 and 1106 of this standard make sites, facilities, buildings and elements accessible to and usable by people with such physical disabilities as the inability to walk, difficulty walking, reliance on walking aids, blindness and visual impairment, deafness and hearing impairment, incoordination, reaching and manipulation disabilities, lack of stamina, difficulty interpreting and reacting to sensory information, and extremes of physical size. The intent of these sections is to allow a person with a physical disability to independently get to, enter, and use a site, facility, building, or element.

Section 1104 of this standard provides criteria for Type B units. These criteria are intended to be consistent with the intent of the criteria of the U.S. Department of Housing and Urban Development (HUD) Fair Housing Accessibility Guidelines. The Type B units are intended to supplement, not replace, Accessible units or Type A units as specified in this standard.

Section 1105 of this standard provides criteria for minimal accessibility features for one and two family dwelling units and townhouses which are not covered by the U.S. Department of Housing and Urban Development (HUD) Fair Housing Accessibility Guidelines.

This standard is intended for adoption by government agencies and by organizations setting model codes to achieve uniformity in the technical design criteria in building codes and other regulations.

**102.1 Applicability.** Sites, facilities, buildings, and elements required **to be accessible by the scoping provisions adopted by the administrative authority** shall comply with the applicable provisions of Chapters 3 through 10. Dwelling units and sleeping units shall comply with the applicable provisions of Chapter 11. (ed.)

## 103 Human Factor Provisions

The technical criteria in this standard are based on body sizes and functional abilities of adults and, in those sections where specifically noted, children (1-4-12) (1-4-12 PC1)

## 104 Compliance Alternatives

Nothing in this standard is intended to prevent the use of designs, products, or technologies as alternatives to those prescribed by this standard, provided they result in equivalent or greater accessibility and such equivalency is approved by the administrative authority adopting this standard. (ed.)

## 105 Conventions

**105.1 General.** Where specific criteria of this standard differ from the general criteria of this standard, the specific criteria shall apply.

**105.2 Calculation of Percentages.** Where the determination of the required size or dimension of an *element* or *facility* involves ratios or percentages, rounding down for values less than one half shall be

permitted. (1-7-12)

**105.3 Dimension tolerances.** All dimensions are subject to conventional industry tolerances except where the requirement is a range with stated minimum and maximum end points. (1-5-12)

**105.4 Figures.** Unless specifically stated, figures included herein are provided for informational purposes only and are not considered part of this standard.

Convention	Description
	dimension showing English units (in inches unless otherwise specified) above the line and SI units (in millimeters unless otherwise specified) below the line
	dimension for small measurements
	dimension showing a range with minimum - maximum
min	minimum
max	maximum
>	greater than
≥	greater than or equal to
<	less than
≤	less than or equal to
	boundary of clear floor space or maneuvering clearance
	centerline
	a permitted element or its extension
	direction of travel or approach
	a wall, floor, ceiling or other element cut in section or plan
	a highlighted element in elevation or plan
	location zone of element, control or feature

*Figure 105.4 – Graphic convention for figures*

**105.5 Floor or Floor Surface.** The terms floor or floor surface refer to the finish floor surface or ground surface, as applicable.

**105.6 Referenced Sections.** Unless specifically stated otherwise, a reference to another section or subsection within this standard includes all subsections of the referenced section or subsection.

## 106 Referenced Documents

**106.1 General.** The documents listed in Section 106.2 shall be considered part of this standard to the ICC/A117.1 - Fourth Public Review Draft – Supplement – August 25, 2016

prescribed extent of each such reference. Where criteria in this standard differ from those of these referenced documents, the criteria of this standard shall apply.

## 106.2 Documents.

*Staff note: When the standard is published – these referenced documents will be placed in alphabetical order with section numbers accordingly.*

**106.2.1 Americans with Disabilities Act (ADA) Accessibility Guidelines for Transportation Vehicles** 36 CFR 1192 published in 56 Federal Register 45558, September 6, 1991 (United States Access Board, 1331 F Street, NW, Suite 1000, Washington, DC 20004-1111)

**106.2.2 Hearing aids – Magnetic field strength in audio-frequency induction loops for hearing aids operating with an induction pickup coil** IEC 60118.4-2007 (International Electrotechnical Commission, 3 rue de Varenbe, PO Box 131, 1211 Geneva 20, Switzerland.) (7-19-12)

~~**106.2.3 Light reflectance value (LRV) of a surface. Method of Test.** BS 8493:2008 + A1: 2010 (British Standards Institution, 389 Chiswick High Road, London W4 4AL, United Kingdom). (7-1-12 -PC3. 7-1-12/3.1/ PC3.3)~~

**106.2.4 Manual on Uniform Traffic Control Devices: MUTCD-2009** (The Federal Highway Administration, Office of Transportation Operations, Room 3408, 400 7th Street, S.W., Washington, DC 20590). (1-8-12)

**106.2.5 National Fire Alarm and Signaling Code: NFPA 72-2010** (National Fire Protection Association, 1 Batterymarch Park, Quincy, MA 02269-9101). (1-8-12)

**106.2.6 Performance Criteria for Accessible Communications Entry Systems.** DASMA 303-2006. (Door and Access Systems Manufacturers Association, 1300 Sumner Avenue, Cleveland, OH 44115-2851)

**106.2.7 Power Assist and Low Energy Power Operated Doors: BHMA A156.19- 2007** (Builders Hardware Manufacturers' Association, 355 Lexington Avenue, 15th Floor, New York, NY 10017)

**106.2.8 Power Operated Pedestrian Doors: ANSI/ BHMA A156.10-2011**(Builders Hardware Manufacturers' Association, 355 Lexington Avenue, 15th Floor, New York, NY 10017). (1-8-12)

**106.2.9 Safety Code for Elevators and Escalators: ASME A17.1- 2013/CSA B44-13** (American Society of Mechanical Engineers International, Three Park Avenue, New York, NY 10016-5990) (1-9-12)

**106.2.10 Safety Standard for Platform Lifts and Stairway Chairlifts: ASME A18.1-2011** (American Society of Mechanical Engineers International, Three Park Avenue, New York, NY 10016-5990). (1-8-12)

**106.2.11 Standard Consumer Safety Performance Specification for Playground Equipment for Public Use** ASTM F 1487-01 (ASTM International, 100 Barr Harbor Drive, PO Box C700, West Conshohocken, PA, 19428-2959)

**106.2.12 Standard Specification for Impact Attenuation of Surfacing Materials Within the Use Zone of Playground Equipment** ASTM F 1292-04 (ASTM International, 100 Barr Harbor Drive, PO Box C700, West Conshohocken, PA, 19428-2959).

**106.2.13 Standard Laboratory Test Method for Determination of Forces and Motions Required to Activate Operable Parts of Operable Windows and Doors in Accessible Spaces, AAMA 513 --14** (AAMA, 1827 Walden Office Square, Suite 550, Schaumburg, IL 60173-4268). (4-23-12 PC2.2)

**106.2.14 Standard Test Method for Determination of Decay Rates for Use in Sound Insulation Test** ICC/A117.1 - Fourth Public Review Draft – Supplement – August 25, 2016

Methods ASTM E 2235-04(2012) (ASTM International, 100 Barr Harbor Drive, PO Box C700, West Conshohocken, PA 19428-2959). (8-15-12 PC5)

## 107 Definitions

**107.1 General.** For the purpose of this standard, the terms listed in Section 107.5 have the indicated meaning.

**107.2 Terms Defined in Referenced Documents.** Terms specifically defined in a referenced document, and not defined in this section, shall have the specified meaning from the referenced document.

**107.3 Undefined Terms.** The meaning of terms not specifically defined in this standard or in a referenced document shall be as defined by collegiate dictionaries in the sense that the context implies.

**107.4 Interchangeability.** Words, terms, and phrases used in the singular include the plural, and those used in the plural include the singular.

### 107.5 Defined Terms.

**accessible:** Describes a site, building, facility, or portion thereof that complies with this standard.

**administrative authority:** A jurisdictional body that adopts or enforces regulations and standards for the design, construction, or operation of buildings and facilities.

**amusement attraction:** Any facility, or portion of a facility, located within an amusement park or theme park which provides amusement without the use of an amusement device. Amusement attractions include, but are not limited to, fun houses, barrels, and other attractions without seats.

**amusement ride:** A system that moves persons through a fixed course within a defined area for the purpose of amusement.

**amusement ride seat:** A seat that is built-in or mechanically fastened to an amusement ride intended to be occupied by one or more passengers.

**area of sport activity:** That portion of a room or space where the play or practice of a sport occurs.

**assembly area.** *A building or facility, or portion thereof, used for the purpose of entertainment, worship, educational or civic gatherings, or similar purposes. For the purposes of these requirements, assembly areas include, but are not limited to, classrooms, lecture halls, courtrooms, public meeting rooms, public hearing rooms, legislative chambers, spaces utilized for viewing motion picture projections, auditoria, theaters, playhouses, dinner theaters, concert halls, centers for the performing arts, amphitheaters, arenas, stadiums, grandstands, places of religious worship or convention centers. (1-10-12)*

**assistive listening system (ALS).** *An amplification system utilizing transmitters, receivers, and coupling devices to bypass the acoustical space between a sound source and a listener by means of induction loop, radio frequency, infrared, or direct-wired equipment. (1-10-12)*

**blended transition.** *A raised pedestrian street crossing, depressed corner, or similar connection between the pedestrian access route at the level of the sidewalk and the level of the pedestrian street crossing that has a grade of 1:20 or less. (4-42-12)*

**boarding pier:** A portion of a pier where a boat is temporarily secured for the purpose of embarking or disembarking.

**boat launch ramp:** A sloped surface designed for launching and retrieving trailered boats and other water craft to and from a body of water.

**boat slip:** That portion of a pier, main pier, finger pier, or float where a boat is moored for the purpose of berthing, embarking, or disembarking.

**catch pool:** A pool or designated section of a pool used as a terminus for water slide flumes.

**characters:** Letters, numbers, punctuation marks, and typographic symbols.

**children's use:** Spaces and elements specifically designed for use primarily by people 12 years old and younger.

**circulation path:** An exterior or interior way of passage provided for pedestrian travel, including but not limited to, walks, hallways, courtyards, elevators, platform lifts, ramps, stairways, and landings. (4-38-12)

**common use.** Interior or exterior circulation paths, rooms, spaces, or elements that are not for public use and are made available for the shared use of two or more people. (4-38-12)

**counter slope:** Any slope opposing the running slope of a curb ramp.

**cross slope:** The slope that is perpendicular to the direction of travel (see running slope).

**curb line.** A line at the face of the curb that marks the transition between curb and the gutter, street or highway. (4-42-12)

**curb ramp.** A short ramp cutting through a curb or built up to it. (4-42-12 PC2)

**destination-oriented elevator system:** An elevator system that provides lobby controls for the selection of destination floors, lobby indicators designating which elevator to board, and a car indicator designating the floors at which the car will stop.

**detectable warning:** A standardized surface feature built in or applied to floor surfaces to warn of hazards on a circulation path.

**dwelling unit:** A single unit providing complete, independent living facilities for one or more persons including permanent provisions for living, sleeping, eating, cooking and sanitation.

**element:** An architectural or mechanical component of a building, facility, space, or site.

**elevated play component:** A play component that is approached above or below grade and that is part of a composite play structure consisting of two or more play components attached or functionally linked to create an integrated unit providing more than one play activity.

**elevator car call sequential step scanning:** A technology used to enter a car call by means of an up or down floor selection button.

**employee work area.** All or any portion of a space used only by employees and used only for work. Corridors, toilet rooms, kitchenettes and break rooms are not employee work areas. (4-38-12)

**existing building.** A building erected prior to the date of adoption of this standard, or one for which a legal building permit has been issued. (3-6-12 PC2) (ETG 8-9-16)

**facility:** All or any portion of a building, structure, site improvements, elements, and pedestrian routes or vehicular ways located on a site.

**gangway:** A variable-sloped pedestrian walkway that links a fixed structure or land with a floating structure. Gangways that connect to vessels are not addressed by this document.



**golf car passage:** A continuous passage on which a motorized golf car can operate.

**grade break.** The line where two surface planes with different grades meet. (4-42-12)

**ground level play component:** A play component that is approached and exited at the ground level.

**habitable:** A space in a building for living, sleeping, eating or cooking. Bathrooms, toilet rooms, closets, halls, storage or utility spaces and similar areas are not considered habitable spaces.

**key surface:** The surface or plane of any key or button that must be touched to activate or deactivate an operable part or a machine function or enter data.

**marked crossing:** A crosswalk or other identified path intended for pedestrian use in crossing a vehicular way.

**operable part:** A component of an element used to insert or withdraw objects, or to activate, deactivate, or adjust the element.

**pictogram:** A pictorial symbol that represents activities, facilities, or concepts.

**play area:** A portion of a site containing play components designed and constructed for children.

**play component:** An element intended to generate specific opportunities for play, socialization, or learning. Play components are manufactured or natural; and are stand-alone or part of a composite play structure.

**ramp:** A walking surface that has a running slope steeper than 1:20.

**running slope:** The slope that is parallel to the direction of travel (see cross slope).

**sign:** An architectural element composed of displayed textual, symbolic, tactile, or pictorial information.

**site:** A parcel of land bounded by a property line or a designated portion of a public right-of-way.

**sleeping unit:** A room or space in which people sleep that can also include permanent provisions for living, sleeping, eating, and either sanitation or kitchen facilities but not both. Such rooms and spaces that are also part of a dwelling unit are not sleeping units.

**soft contained play structure:** A play structure made up of one or more play components where the user enters a fully enclosed play environment that utilizes pliable materials, such as plastic, netting, or fabric.

**teeing ground:** In golf, the starting place for the hole to be played.

**transfer device:** Equipment designed to facilitate the transfer of a person from a wheelchair or other mobility aide to and from an amusement ride seat.

**transition plate.** A sloping pedestrian walking surface located at the ends of a *gangway*. (1-10-12)

**TTY:** An abbreviation for teletypewriter. Equipment that employs interactive, text-based communications through the transmission of coded signals across the standard telephone network. The term TTY also refers to devices known as text telephones and TDDs.

**use zone:** The ground level area beneath and immediately adjacent to a play structure or play equipment that is designated by ASTM F 1487 listed in Section 106.2.11, for unrestricted circulation

around the play equipment and where it is predicted that a user would land when falling from or exiting the play equipment.

**variable message signs (VMS):** Electronic signs that have a message with the capacity to change by means of scrolling, streaming, or paging across a background.

**variable message sign (VMS) characters:** Characters of an electronic sign are composed of pixels in an array. High resolution VMS characters have vertical pixel counts of 16 rows or greater. Low resolution VMS characters have vertical pixel counts of 7 to 15 rows.

**vehicular way.** [A route provided for vehicular traffic, such as in a street, driveway, or parking facility.](#)  
(1-10-12)

**walk:** An exterior pathway with a prepared surface for pedestrian use.

**wheelchair charging area:** [A clear floor area where people with disabilities can recharge their wheelchair batteries.](#)(10-10-12)

**wheelchair space:** A space for a single wheelchair and its occupant.

**wheelchair space locations:** A space for a minimum of a single wheelchair and the associated companion seating. Wheelchair space locations can contain multiple wheelchair spaces and associated companion seating.

## Chapter 2. Scoping

### 201 General

This standard provides technical criteria for making sites, facilities, buildings, and elements accessible. The administrative authority shall provide scoping provisions to specify the extent to which these technical criteria apply. These scoping provisions shall address the application of this standard to: each building and occupancy type; new construction, alterations, temporary facilities, and existing buildings; specific site and building elements; and to multiple elements or spaces provided within a site or building.

### \*\*202 Dwelling and Sleeping Units

Chapter 11 of this standard contains dwelling unit and sleeping unit criteria for Accessible units, Type A units, Type B units, Type C (Visitable) dwelling units and units with **communication features**. The administrative authority shall specify, in separate scoping provisions, the extent to which these technical criteria apply. These scoping provisions shall address the types and numbers of units required to comply with each set of unit criteria. (ed.)

### 203 Administration

The administrative authority shall provide an appropriate review and approval process to ensure compliance with this standard.



## Chapter 3. Building Blocks

### 301 General

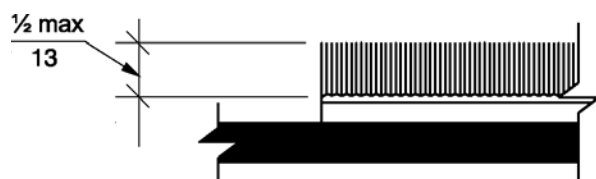
**301.1 Scope.** The provisions of Chapter 3 shall apply where required by the scoping provisions adopted by the administrative authority or by Chapters 4 through 11.

**301.2 Overlap.** Unless otherwise specified, clear floor spaces, clearances at fixtures, maneuvering clearances at doors, and turning spaces shall be permitted to overlap.

### 302 Floor Surfaces

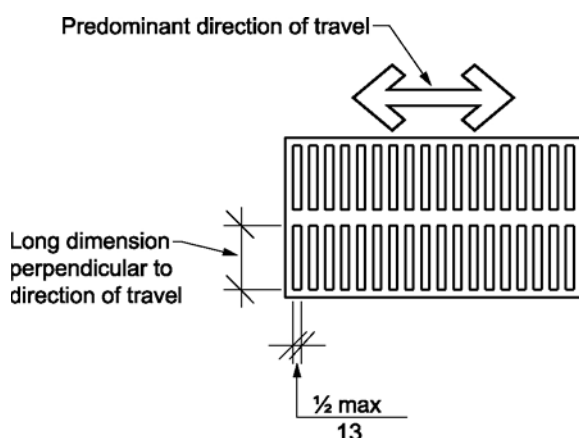
**302.1 General.** Floor surfaces shall be stable, firm, and slip resistant, and shall comply with Section 302. Changes in level in floor surfaces shall comply with Section 303.

**302.2 Carpet.** Carpet or carpet tile shall be securely attached and shall have a firm cushion, pad, or backing or no cushion or pad. Carpet or carpet tile shall have a level loop, textured loop, level cut pile, or level cut/uncut pile texture. The pile shall be  $\frac{1}{2}$  inch (13 mm) maximum in height. Exposed edges of carpet shall be fastened to the floor and shall have trim along the entire length of the exposed edge. Carpet edge trim shall comply with Section 303.



*Figure 302.2 Carpet on floor surface*

**302.3 Openings.** Openings in floor surfaces shall be of a size that does not permit the passage of a  $\frac{1}{2}$  inch (13 mm) diameter sphere, except as allowed in Sections 407.4.3, 408.4.3, 409.4.3, 410.4, and 805.10. Elongated openings shall be placed so that the long dimension is perpendicular to the predominant direction of travel.



*Figure 302.3 Openings in floor surface*

### 303 Changes in Level

**303.1 General.** Changes in level in floor surfaces shall comply with Section 303.

**303.2 Vertical.** Changes in level of 1/4 inch (6.4 mm) maximum in height shall be permitted to be vertical.



Figure 303.2 Vertical Change in level

**303.3 Beveled.** Changes in level greater than 1/4 inch (6.4 mm) in height and not more than 1/2 inch (13 mm) maximum in height shall be beveled with a slope not steeper than 1:2. (3-4-12 PC4/PC5)

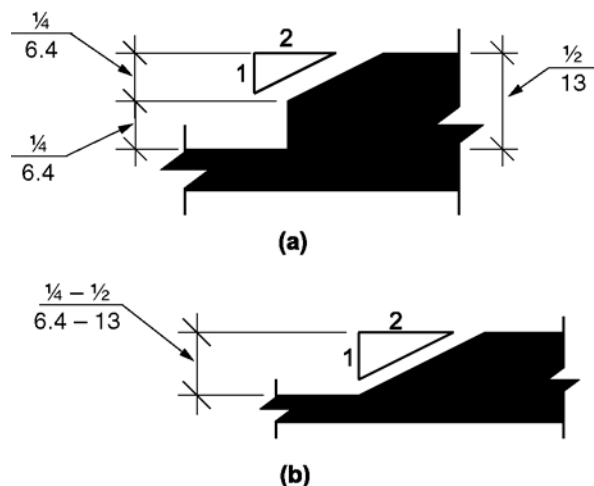


Figure 303.3 (a) & (b) Beveled change in level

**303.4 Ramps.** Changes in level greater than 1/2 inch (13 mm) in height shall be ramped and shall comply with Section 405 or 406.

### 304 Turning Space

**304.1 General.** A turning space shall comply with Section 304.

**304.2 Floor Surface.** Floor surfaces of a turning space shall comply with Section 302. Changes in level shall not be permitted within the turning space. (ed.)

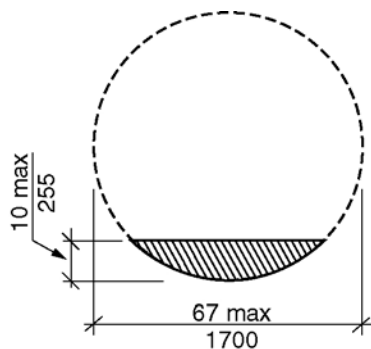
**EXCEPTION:** Slopes not steeper than 1:48 shall be permitted. (3-5-12)

**304.3 Size.** Turning spaces shall comply with Section 304.3.1 or 304.3.2.

#### 304.3.1 Circular Space.

**304.3.1.1 New buildings.** In new buildings, the turning space shall be a circular space with a 67 inch (1700 mm) minimum diameter. The turning space shall be permitted to include knee and toe clearance complying with Section 306. Where the turning space includes knee and toe clearances under an obstruction, the overlap shall comply with all of the following: . (3-6-12) (3-8-12)

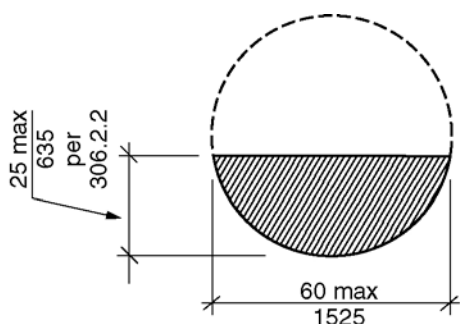
1. The depth of the overlap shall not be more than 10 inches (255 mm), and
2. The depth shall not exceed the depth of the knee and toe clearances provided, and
3. The overlap shall be permitted only within the turning circle area shown shaded in Figure 304.3.1. (3-8-12)



Overlap of knee and toe clearance

Figure 304.3.1.1 Circular turning space – new buildings– size and overlap

**304.3.1.2 Existing buildings.** In existing buildings, the turning space shall be a circular space with a 60 inch (1525 mm) minimum diameter. The turning space shall be permitted to include knee and toe clearance complying with Section 306. (3-6-12 PC2)



Overlap of knee and toe clearance

Figure 304.3.1.2 Circular turning space – existing buildings – size and overlap

### 304.3.2 T-Shaped Space.

**304.3.2.1 New construction.** In new buildings, The turning space shall be a T-shaped space complying with one of the following:

1. A T-shaped space, clear of obstruction, that fits within an area 68 inches (1725 mm) wide and 60 inches (1525 mm) deep, with two arms and one base that are all 36 inches (915 mm) minimum in width. Each arm shall extend 16 inches (405 mm) minimum from each side of the base located opposite the other, and the base shall extend 24 inches (610 mm) minimum from the arms. At the intersection of each arm and the base, the interior corners shall be chamfered for 8 inches (205 mm) minimum along both the arm and along the base.
2. A T-shaped space, clear of obstruction, that fits within an area 64 inches (1625 mm) wide and 60 inches (1525 mm) deep, with two arms 38 inches (965 mm) minimum in width and a base 42 inches (1065 mm) minimum in width. Each arm shall extend 11 inches (280 mm) minimum from each side of the base, located opposite the other, and the base shall extend 22 inches (560 mm) minimum from each arm.
3. A T-shaped space, clear of obstruction, 64 inches (1625 mm) wide and 60 inches (1525 mm) deep, with two arms and one base 40 inches (1015 mm) minimum in width. **Each arm shall extend 12 inches (305 mm) minimum from each side of the base and the base shall extend 20 inches (510**

mm) minimum from each arm. (3-9-12)(3-9-12 PC3) (ed.)

**Exception:** The turning space shall be permitted to include knee and toe clearance complying with Section 306 for the portions beyond the chamfer of either the base or one arm. (7-5-16) (ed.)

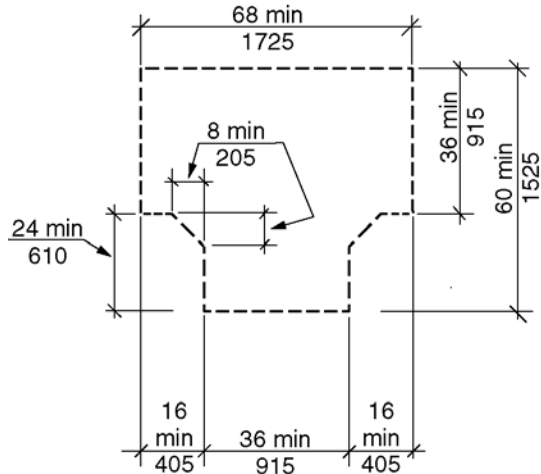


Figure 304.3.2.1(a) T-shaped turning space- new buildings - Option 1

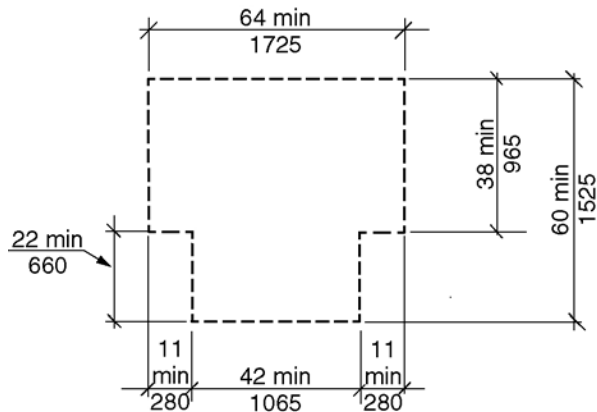


Figure 304.3.2.1(b) T-shaped turning space- new buildings - Option 2

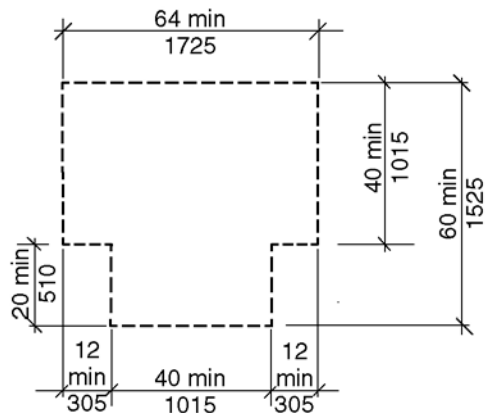


Figure 304.3.2.1(c) T-shaped turning space buildings - Option 3



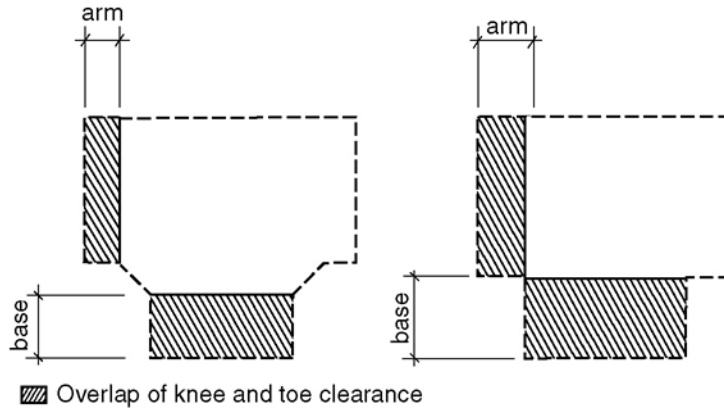


Figure 304.3.2.1(d) T-shaped turning space – new buildings - Overlap

**304.3.2.2 Existing buildings.** In existing buildings, the turning space shall be a T-shaped space within a 60-inch (1525 mm) minimum square, with arms and base 36 inches (915 mm) minimum in width. Each arm of the T shall be clear of obstructions 12 inches (305 mm) minimum in each direction, and the base shall be clear of obstructions 24 inches (610 mm) minimum. The turning space shall be permitted to include knee and toe clearance complying with Section 306 only at the end of either the base or one arm. (3-6-12 PC2)

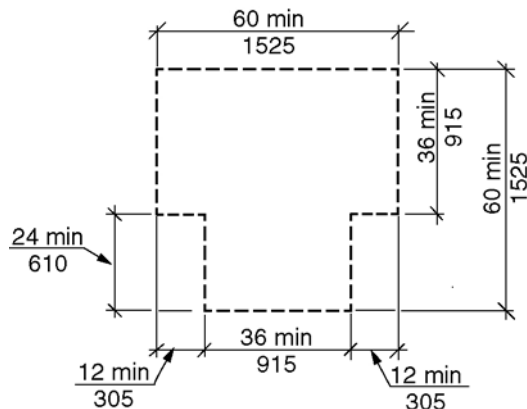


Figure 304.3.2.2(a) T-shaped turning space – existing buildings – size

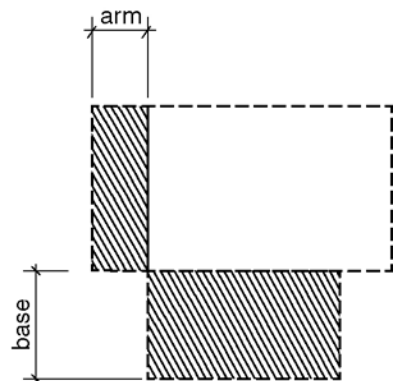


Figure 304.3.2.2(b) T-shaped turning space existing buildings – overlap

**304.4 Door Swing.** Unless otherwise specified, doors shall be permitted to swing into turning spaces.

**305 Clear Floor Space**

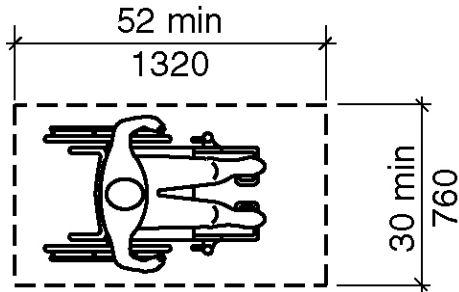
**305.1 General.** A clear floor space shall comply with Section 305.

**305.2 Floor Surfaces.** Floor surfaces of a clear floor space shall comply with Section 302. Changes in level shall not be permitted within the clear floor space. (ed.)

**EXCEPTION:** Slopes not steeper than 1:48 shall be permitted. (3-5-12)

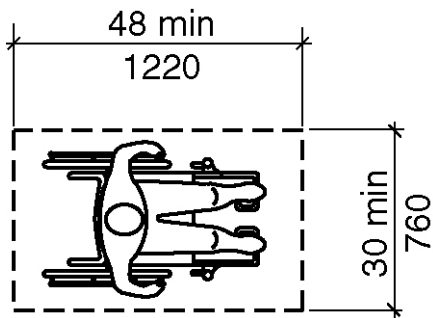
**305.3 Size.**

**305.3.1 New buildings.** In new buildings, the clear floor space shall be 52 inches (1320 mm) minimum in length and 30 inches (760 mm) minimum in width. (3-13-12)



*Figure 305.3.1 - Size of clear floor space – new buildings*

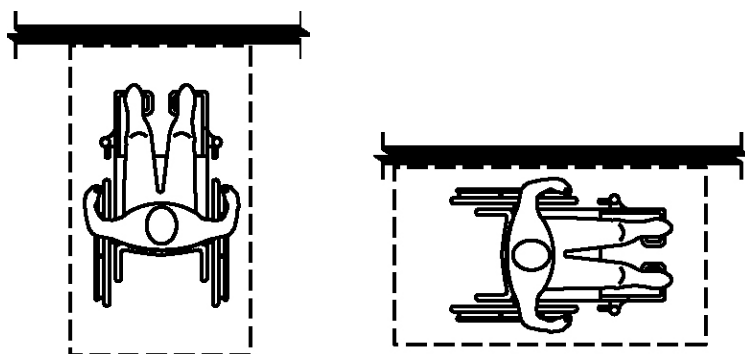
**\*\*305.3.2 Existing buildings and within new Type B units.** In existing construction and within new Type B units, the clear floor space shall be 48 inches (1220 mm) minimum in length and 30 inches (760 mm) minimum in width. (3-6-12 PC2) (ed.)



*Figure 305.3.2 - Size of clear floor space – existing buildings*

**305.4 Knee and Toe Clearance.** Unless otherwise specified, clear floor space shall be permitted to include knee and toe clearance complying with Section 306.

**305.5 Position.** Unless otherwise specified, the clear floor space shall be positioned for either forward or parallel approach to an element.

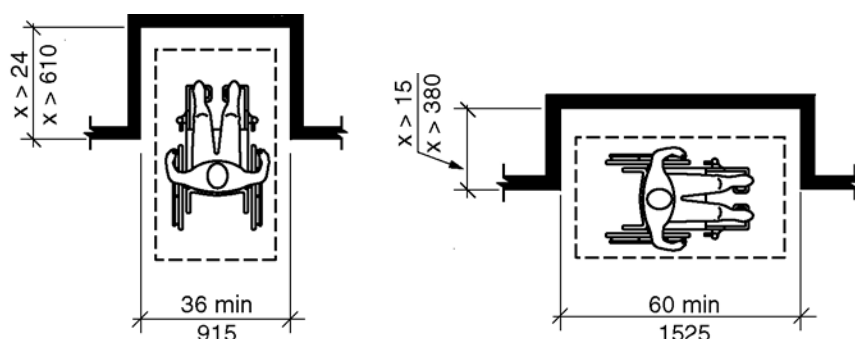


**Figure 305.5** Position of clear floor space

- a) forward  
b) parallel

**305.6 Approach.** One full, unobstructed side of the clear floor space shall adjoin or overlap an accessible route or adjoin another clear floor space.

**305.7 Alcoves.** If a clear floor space is in an alcove or otherwise confined on all or part of three sides, additional maneuvering clearances complying with Sections 305.7.1 and 305.7.2 shall be provided, as applicable.



**Figure 305.7** Maneuvering clearance in an alcove

- a) forward approach  
b) parallel approach

**305.7.1 Parallel Approach.** Where the clear floor space is positioned for a parallel approach, the alcove shall be 60 inches (1525 mm) minimum in width where the depth exceeds 15 inches (380 mm).

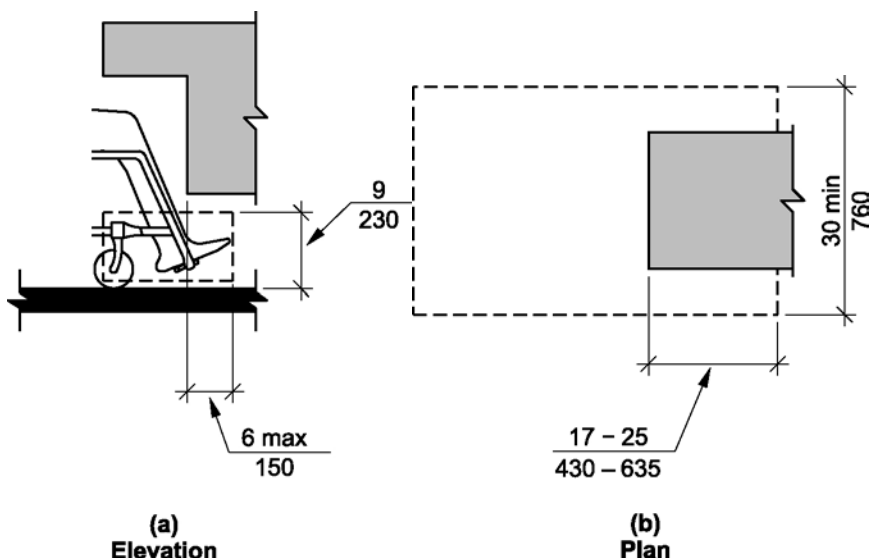
**305.7.2 Forward Approach.** Where the clear floor space is positioned for a forward approach, the alcove shall be 36 inches (915 mm) minimum in width where the depth exceeds 24 inches (610 mm) (3-13-12 PC4.1) (ed.)

~~**305.8 Seat Back Location.** For purposes of this standard, the seat back of a wheelchair within the clear floor space shall be considered 40 inches (1015 mm) from the front or 12 inches (305 mm) from the rear of the wheelchair space. (6-46-12 PC2.1) (6-46-12/2.1-PC2.1 Agenda #25.1)~~

### 306 Knee and Toe Clearance

**306.1 General.** Where space beneath an element is included as part of clear floor space at an element, clearance at an element, or a turning space, the space shall comply with Section 306. Additional space shall not be prohibited beneath an element, but shall not be considered as part of the clear floor space or turning space.

### 306.2 Toe Clearance.



*Figure 306.2 – Toe clearance*

*a) elevation*

*b) plan*

**306.2.1 General.** Space beneath an element between the floor and 9 inches (230 mm) above the floor shall be considered toe clearance and shall comply with Section 306.2.

**306.2.2 Maximum Depth.** Toe clearance shall be permitted to extend 25 inches (635 mm) maximum under an element.

**306.2.3 Minimum Depth.** Where toe clearance is required at an element as part of a clear floor space complying with Section 305, the toe clearance shall extend 17 inches (430 mm) minimum beneath the element.

**306.2.4 Additional Clearance.** Space extending greater than 6 inches (150 mm) beyond the available knee clearance at 9 inches (230 mm) above the floor shall not be considered toe clearance.

**306.2.5 Width.** Toe clearance shall be 30 inches (760 mm) minimum in width.

### 306.3 Knee Clearance.

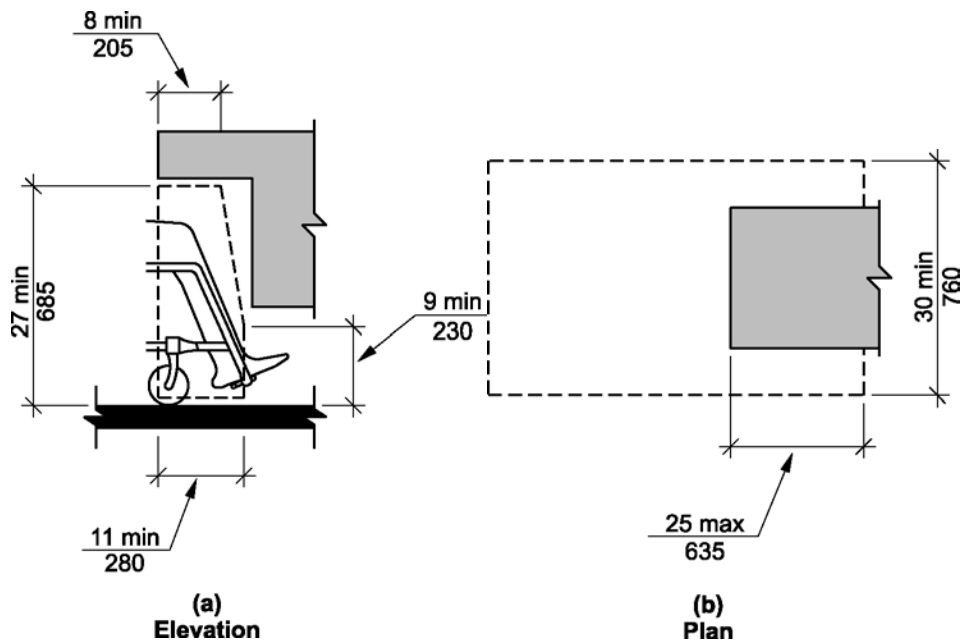


Figure 306.3 – Knee clearance

a) elevation

b) plan

**306.3.1 General.** Space beneath an element between 9 inches (230 mm) and 27 inches (685 mm) above the floor shall be considered knee clearance and shall comply with Section 306.3.

**306.3.2 Maximum Depth.** Knee clearance shall be permitted to extend 25 inches (635 mm) maximum under an element at 9 inches (230 mm) above the floor.

**306.3.3 Minimum Depth.** Where knee clearance is required beneath an element as part of a clear floor space complying with Section 305, the knee clearance shall be 11 inches (280 mm) minimum in depth at 9 inches (230 mm) above the floor, and 8 inches (205 mm) minimum in depth at 27 inches (685 mm) above the floor.

**306.3.4 Clearance Reduction.** Between 9 inches (230 mm) and 27 inches (685 mm) above the floor, the knee clearance shall be permitted to be reduced at a rate of 1 inch (25 mm) in depth for each 6 inches (150 mm) in height.

**306.3.5 Width.** Knee clearance shall be 30 inches (760 mm) minimum in width.

### 307 Protruding Objects

**307.1 General.** Protruding objects on circulation paths shall comply with Section 307.

**307.2 Protrusion Limits.** Objects with leading edges more than 27 inches (685 mm) and not more than 80 inches (2030 mm) above the floor shall protrude 4 inches (100 mm) maximum horizontally into the circulation path.

**EXCEPTION:** Handrails shall be permitted to protrude 4 1/2 inches (115 mm) maximum.

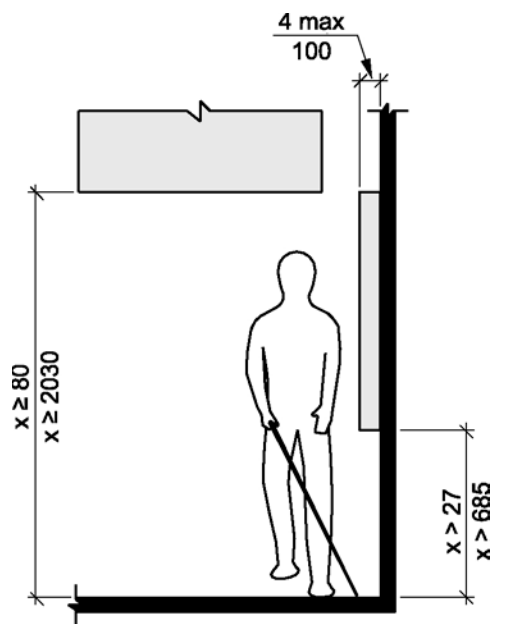
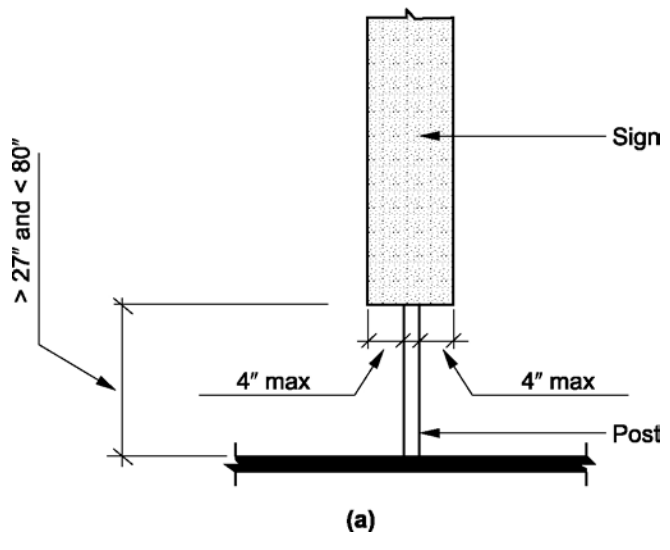


Figure 307.2 Limits of protruding objects

**307.3 Post-Mounted Objects.** Objects on posts or pylons shall be permitted to overhang 4 inches (100 mm) maximum where more than 27 inches (685 mm) and not more than 80 inches (2030 mm) above the floor. Objects on multiple posts or pylons where the clear distance between the posts or pylons is greater than 12 inches (305 mm) shall have the lowest edge of such object either 27 inches (685 mm) maximum or 80 inches (2030 mm) minimum above the floor.

**EXCEPTION:** Sloping portions of handrails between the top and bottom riser of stairs and above the ramp run shall not be required to comply with Section 307.3.



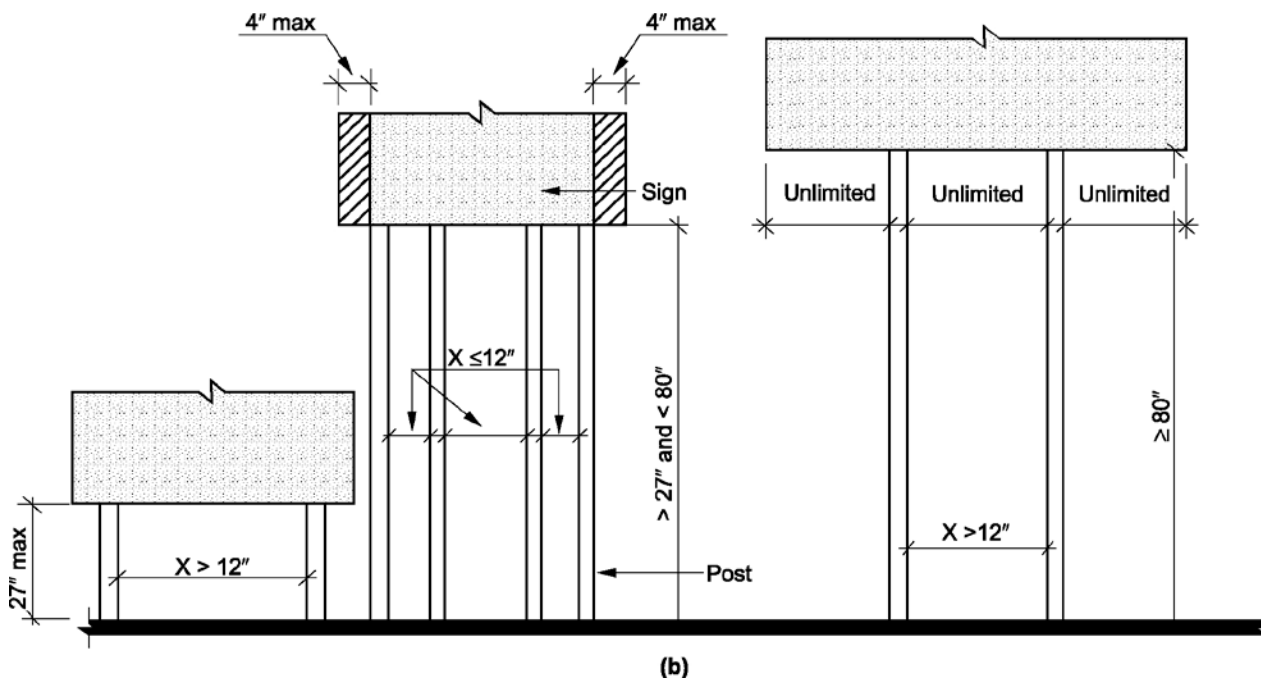


Figure 307.3 (a)&(b) Post-mounted protruding objects

**307.4 Vertical Clearance.** Vertical clearance shall be 80 inches (2030 mm) minimum in height. Rails or other barriers shall be provided where the vertical clearance is less than 80 inches (2030 mm) in height. The leading edge of such rails or barrier shall be located 27 inches (685 mm) maximum above the floor.

**EXCEPTION:** Door closers and door stops shall be permitted to be 78 inches (1980 mm) minimum above the floor.

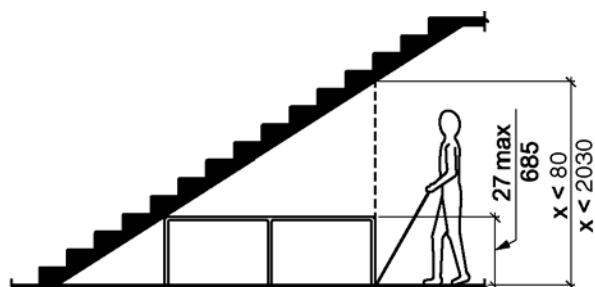


Figure 307.4 Reduced vertical clearance

**307.5 Required Clear Width.** Protruding objects shall not reduce the clear width required for **accessible** routes.

### 308 Reach Ranges

**308.1 General.** Reach ranges shall comply with Section 308.

#### 308.2 Forward Reach.

**308.2.1 Unobstructed.** Where a forward reach is unobstructed, the high forward reach shall be 48 inches (1220 mm) maximum and the low forward reach shall be 15 inches (380 mm) minimum above the floor. (3-20-12 PC1, PC3 through PC6) (3-6-12 PC2.1)

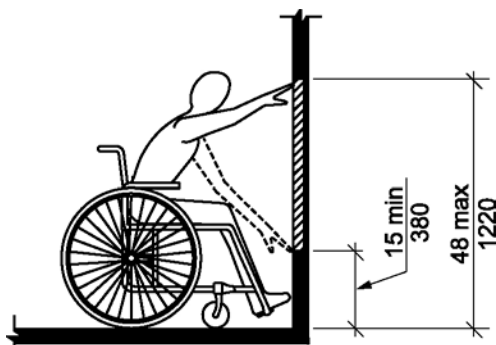


Figure 308.2.1 Unobstructed forward reach

**308.2.2 Obstructed High Reach.** Where a high forward reach is over an obstruction, the clear floor space complying with Section 305 and knee and toe clearance complying with Section 306 shall extend beneath the element for a distance not less than the reach depth over the obstruction. The high forward reach shall be 48 inches (1220 mm) maximum above the floor where the reach depth over the obstruction is 20 inches (510 mm) maximum. The high forward reach shall be 44 inches (1120 mm) maximum above the floor where the reach depth over the obstruction is greater than 20 inches (510 mm) and not more than 25 inches (635 mm). (3-20-12)(3-21-12 PC2)

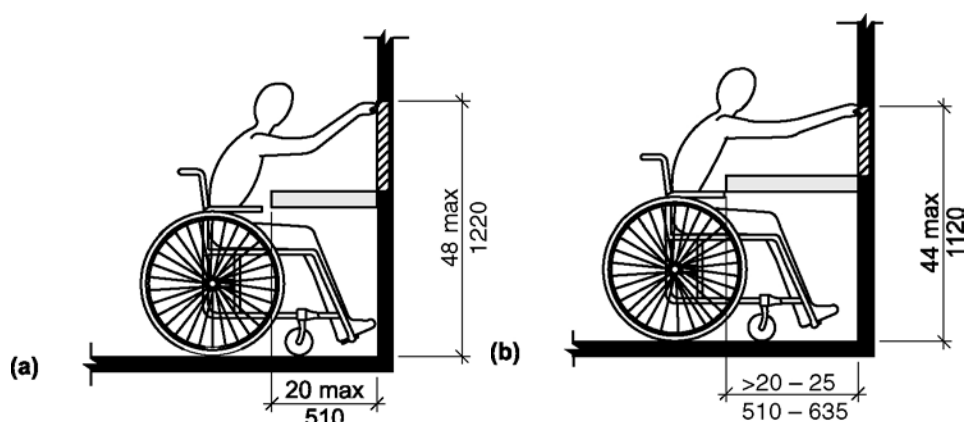


Figure 308.2.2 (a)&(b) Obstructed high forward reach

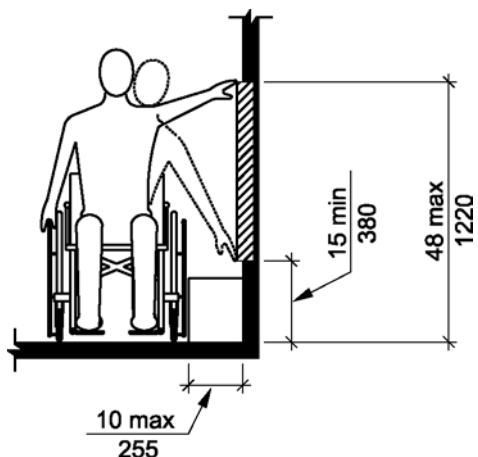
### 308.3 Side Reach.

**308.3.1 Unobstructed.** Where a clear floor space complying with Section 305 allows a parallel approach to an element and the edge of the clear floor space is 10 inches (255 mm) maximum from the element, the high side reach shall be 48 inches (1220 mm) maximum and the low side reach shall be 15 inches (380 mm) minimum above the floor.

#### EXCEPTIONS:

1. Existing elements that are not altered shall be permitted at 54 inches (1370 mm) maximum above the floor.
2. Operable parts on fuel dispensers installed on an existing curbs shall be permitted at 54 inches (1370 mm) maximum above the floor. (3-23-12)
3. ~~Mailboxes serving Type B dwelling units and complying with Section 1101.2 shall be permitted an unobstructed high side reach 54 inches (1370 mm) maximum above the floor. (3-24-12 PC1) (7-5-16) (ed.)~~

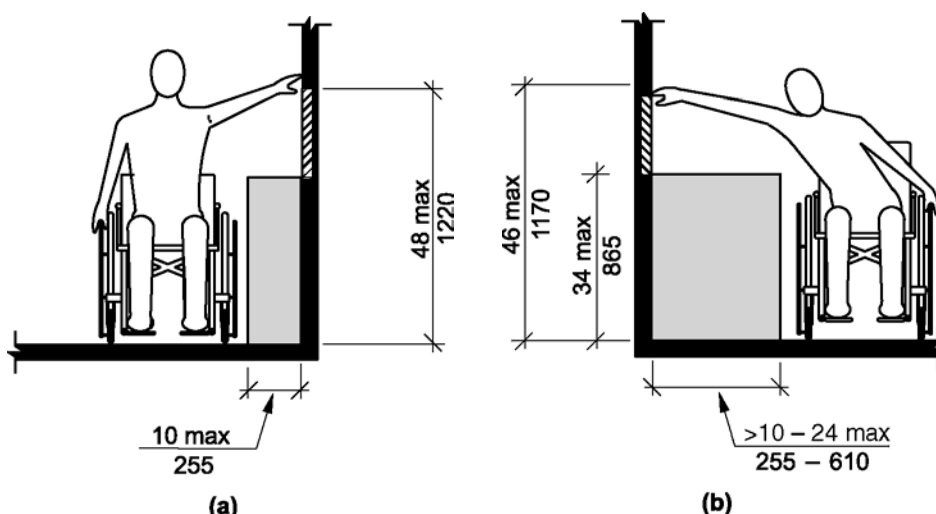




**Figure 308.3.1 - Unobstructed side reach**

**308.3.2 Obstructed High Reach.** Where a clear floor space complying with Section 305 allows a parallel approach to an element and the high side reach is over an obstruction, the height of the obstruction shall be 34 inches (865 mm) maximum above the floor and the depth of the obstruction shall be 24 inches (610 mm) maximum. The high side reach shall be 48 inches (1220 mm) maximum above the floor for a reach depth of 10 inches (255 mm) maximum. Where the reach depth exceeds 10 inches (255 mm), the high side reach shall be 46 inches (1170 mm) maximum above the floor for a reach depth of 24 inches (610 mm) maximum.

**EXCEPTION:** ~~At washing machines and clothes dryers, the height of the obstruction shall be permitted to be 36 inches (915 mm) maximum above the floor. (6-69-12)~~



**Figure 308.3.2 (a)&(b) - Obstructed high side reach**

### 309 Operable Parts

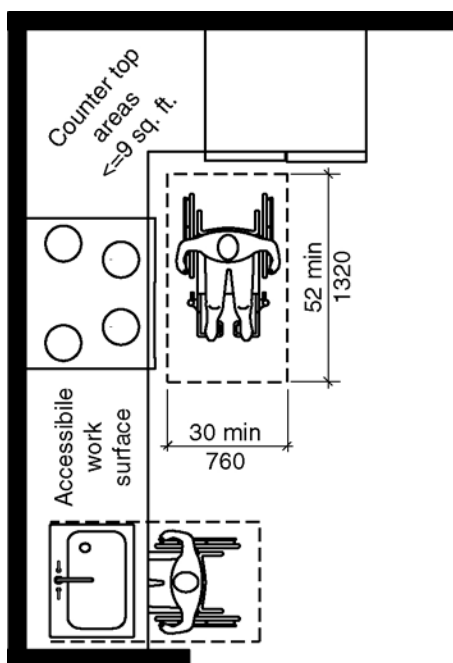
**309.1 General.** Operable parts ~~required to be accessible~~ shall comply with Section 309. (ed.)

#### EXCEPTIONS:

1. Receptacle outlets serving a dedicated use.
2. Where two or more receptacle outlets are provided in a kitchen above a length of counter top that is uninterrupted by a sink or appliance, one receptacle outlet shall not be required to comply with

## Section 309.

3. In a kitchen, where a clear floor space for a parallel approach cannot be located at a counter top in a corner between appliances, receptacle outlets over the counter top shall not be required to comply with Section 309 provided that the counter top area does not exceed 9 square feet (0.835 m<sup>2</sup>) maximum. (10-8-12 PC2) (7-5-16)
4. Floor receptacle outlets.
5. HVAC diffusers.
6. Controls mounted on ceiling fans.
7. Where redundant controls other than light switches are provided for a single element, one control in each space shall not be required to **comply with Section 309. (ed.)**
8. Reset buttons and shut-offs serving appliances, piping and plumbing fixtures.
9. Electrical panelboards shall not be required to comply with Section 309.4. (3-27-12)
10. Emergency aid devices, such as fire department hose connections, valve controls, gauges, police call boxes and annunciator panels shall not be required to comply with Section 309 provided that they are used only for emergencies by emergency personnel acting in their official capacity. (5-24-12 PC1.1)



**Figure 309.1 - Operable parts – Exception 3**

**309.2 Clear Floor Space.** A clear floor space complying with Section 305 shall be provided.

**309.3 Height.** Operable parts shall be placed within one or more of the reach ranges specified in Section 308.

**309.4 Operation.** Operable parts shall be operable with one hand and shall not require tight grasping,

pinching, or twisting of the wrist. The force required to activate operable parts shall be 5.0 pounds (22.2 N) maximum.

**EXCEPTION:** Gas pump nozzles shall not be required to provide operable parts that have an activating force of 5.0 pounds (22.2 N) maximum.



## Chapter 4. Accessible Routes

### 401 General

**401.1 Scope.** Accessible routes required by the scoping provisions adopted by the administrative authority shall comply with the applicable provisions of Chapter 4.

### 402 Accessible Routes

**402.1 General.** Accessible routes shall comply with Section 402.

**402.2 Components.** Accessible routes shall consist of one or more of the following components: *Walking surfaces with a running slope not steeper than 1:20, doors and doorways, gates, ramps, curb ramps excluding the flared sides, blended transitions, elevators, and platform lifts.* All components of an accessible route shall comply with the applicable portions of this standard. (4-2-12) (4-11-12)

**402.3 Revolving Doors, Revolving Gates, and Turnstiles.** Revolving doors, revolving gates, and turnstiles shall not be part of an accessible route.

### 403 Walking Surfaces

**403.1 General.** Walking surfaces that are a part of an accessible route shall comply with Section 403.

**403.2 Floor Surface.** Floor surfaces shall comply with Section 302.

**403.3 Slope.** The running slope of walking surfaces shall not be steeper than 1:20. The cross slope of a walking surface shall not be steeper than 1:48.

**403.4 Changes in Level.** Changes in level shall comply with Section 303.

**403.5 Clear width.** *The clear width of an accessible route shall comply with Section 403.5.1, 403.5.2, 403.5.3 or 403.5.4 as applicable.* (4-5-12)

**403.5.1 General.** *The clear width of an interior accessible route shall be 36 inches (915 mm) minimum. The clear width of an exterior accessible route shall be 48 inches (1220 mm) minimum.* (4-7-12) (4-5-12)

#### EXCEPTIONS:

1. *In new buildings* the clear width shall be permitted to be reduced to 32 inches (815 mm) minimum for a length of 24 inches (610 mm) maximum provided the reduced width segments are separated by segments that are *52 inches (1320 mm)* minimum in length and 36 inches (915 mm) minimum in width. (4-6-12)
2. *In existing buildings and within new Type-B units,* the clear width shall be permitted to be reduced to 32 inches (815 mm) minimum for a length of 24 inches (610 mm) maximum provided the reduced width segments are separated by segments that are 48 inches (1220 mm) minimum in length and 36 inches (915 mm) minimum in width. (3-6-12 PC2) (ed.)
3. ~~The clear width of a circulation path of a Type-C dwelling unit shall be 36 inches (915 mm) minimum. (4-7-12 PC1) (ed.)~~

3. The clear width of an exterior accessible route located within seating areas shall be 36 inches (915 mm) minimum. (4-7-12 PC1)
4. The clear width of an exterior ramp shall comply with Section 405.5

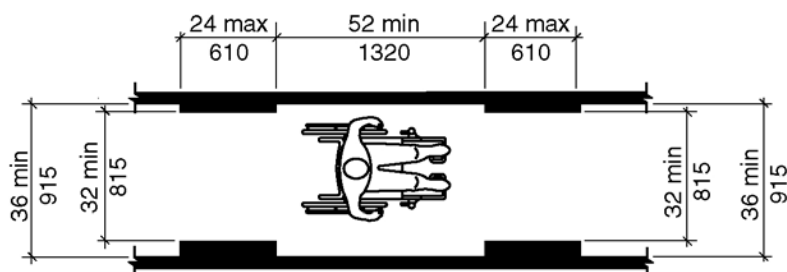


Figure 403.5.1(a) - Clear width of an accessible route – new buildings– interior

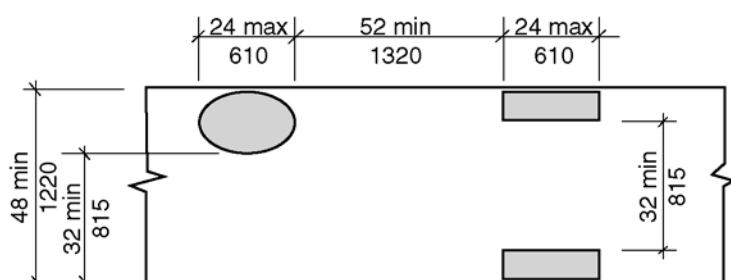


Figure 403.5.1(b) - Clear width of an accessible route – new buildings – exterior

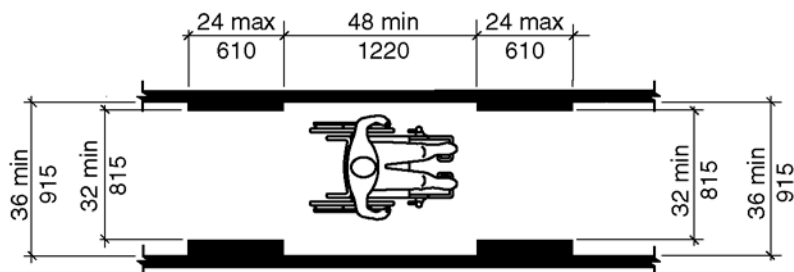


Figure 403.5.1(c) - Clear width of an accessible route – existing buildings – interior

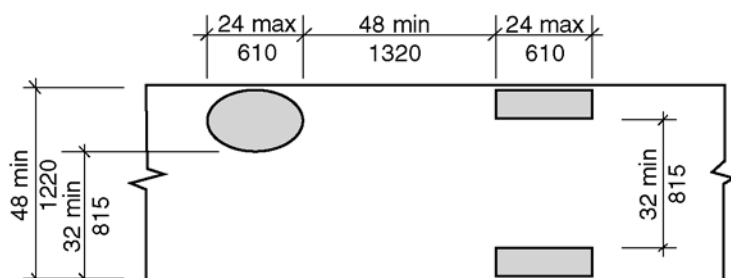


Figure 403.5.1(d) - Clear width of an accessible route – existing buildings - exterior

#### 403.5.2 Clear Width at 180 Degree Turn.

**403.5.2.1 New buildings.** In new buildings, where an accessible route makes a 180 degree turn around an object that is equal to or greater than 52 inches (1320 mm) in width, the clear widths in the turn shall comply with Section 403.5.1. Where an accessible route makes a 180 degree turn around an object that is less than 52 inches (1320 mm) inches in width, the clear widths approaching the turn, during the turn and leaving the turn, shall be one of the following sets of dimensions: (4-5-12)

1. Approaching width is 36 inches (915 mm) minimum, during width is 60 inches (1525 mm) minimum, and leaving width is 36 inches (915 mm) minimum.
2. Approaching width is 42 (1065 mm) inches minimum, during width is 48 inches (1220 mm) minimum, and leaving width is 42 (1065 mm) inches minimum.
3. Approaching width is 43 inches (1090 mm) minimum, during width is 43 inches (1090 mm) minimum, and leaving width is 43 inches (1090 mm) minimum. (4-8-12)

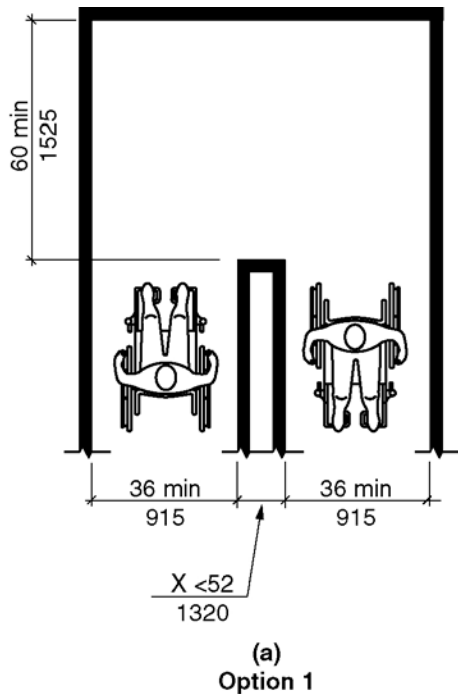


Figure 403.5.2.1(a) - Clear width at 180 degree turn – new buildings– Option 1

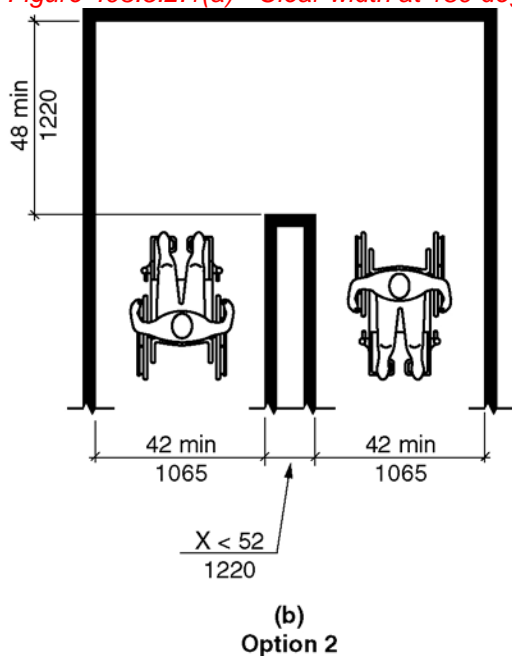
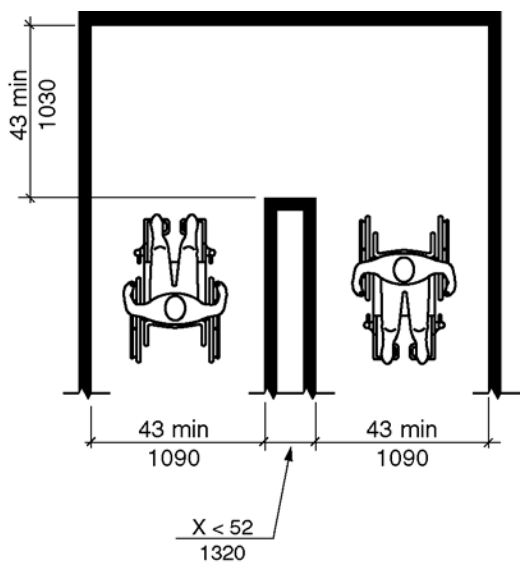


Figure 403.5.2.1(b) - Clear width at 180 degree turn – new building – Option 2

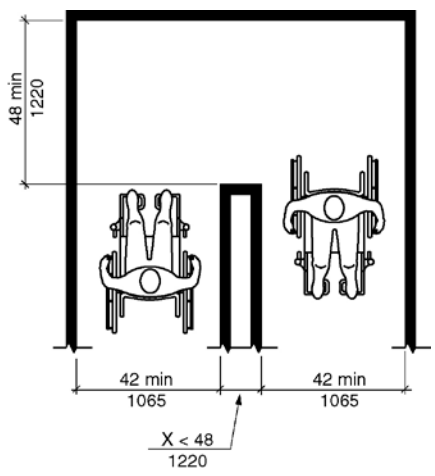


(c)  
Option 3

Figure 403.5.2.1(c) - Clear width at 180 degree turn – new buildings – Option 3

**403.5.2.2 Existing buildings and within new Type B units.** In existing buildings and within new Type B units, where an accessible route makes a 180 degree turn around an object that is less than 48 inches (1220 mm) in width, clear widths shall be 42 inches (1065 mm) minimum approaching the turn, 48 inches (1220 mm) minimum during the turn and 42 (1065 mm) inches minimum leaving the turn.

**EXCEPTION:** Section 403.5.4 This section shall not apply where the clear width during the turn is 60 inches (1525 mm) minimum. (3-6-12 PC1)



(a)  
180 Degree Turn

Figure 403.5.2.2(a) - Clear width at 180 degree turn – existing buildings



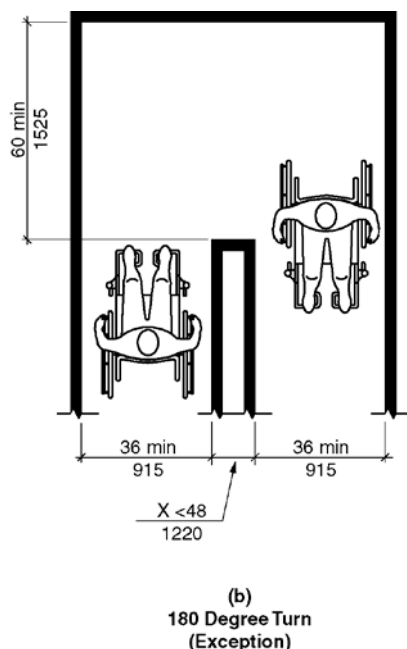


Figure 403.5.2.2(b) - Clear width at 180 degree turn – existing buildings - exception

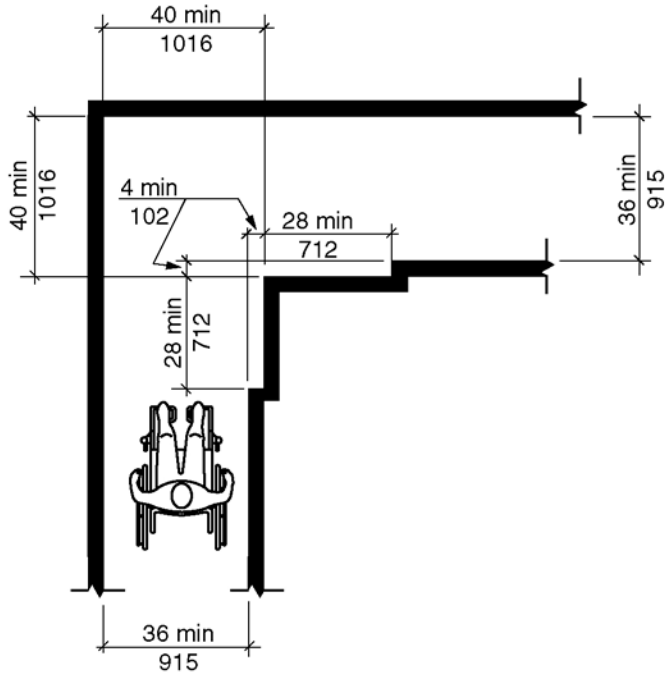
### 403.5.3 Clear Width at 90 Degree Turn.

**403.5.3.1 New buildings.** In new buildings, where an accessible route makes a 90 degree turn the clear widths approaching the turn and leaving the turn shall be one of the following sets of dimensions:

1. Both legs of the turn shall be 40 inches (1016 mm) minimum in width. The width of each leg of the turn shall be maintained for 28 inches (712 mm) minimum from the inner corner.
2. Where the interior corners of the turn are chamfered for 8 inches minimum (205 mm) along both walls, both legs of the turn shall be 36 inches (915 mm) minimum in width. (4-9-12) (4-10-12)
3. Where one leg of the turn is 42 inches (1065 mm) minimum in width, the other shall be permitted to be 38 inches (965 mm) minimum in width. (4-10-12)
4. Where one leg of the turn is 44 inches (1115 mm) minimum in width, the other shall be permitted to be 36 inches (915 mm) minimum in width. (4-10-12)

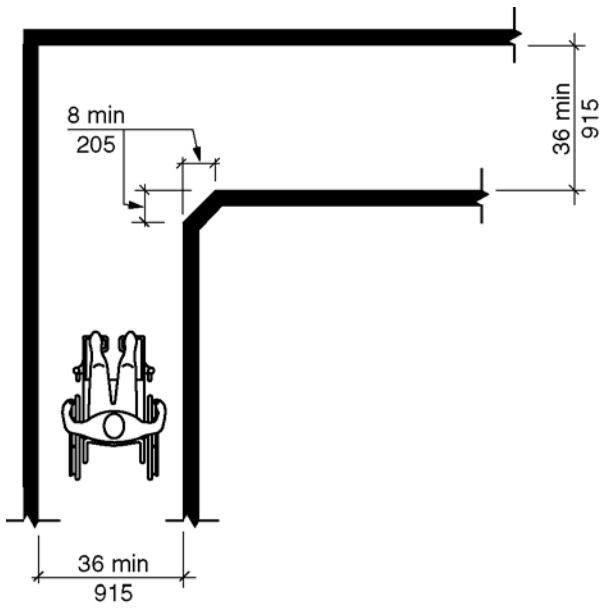
#### **Exceptions:**

1. Where an accessible route makes a 90 turn at doors and doorways complying with Section 404.2.3, the route shall not be required to comply with section. (ed.)
2. Where an accessible route makes a 90 turn at an elevator or platforms lifts complying with Sections 407 through 410, the accessible route shall not be required to comply with this section. (ed.)



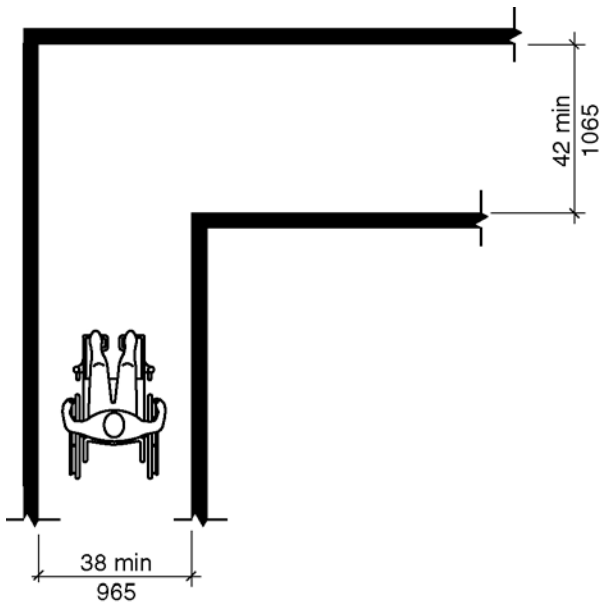
(a)  
Option 1

Figure 403.5.3.1(a) - Clear width at 90 degree turn – new buildings – Option 1



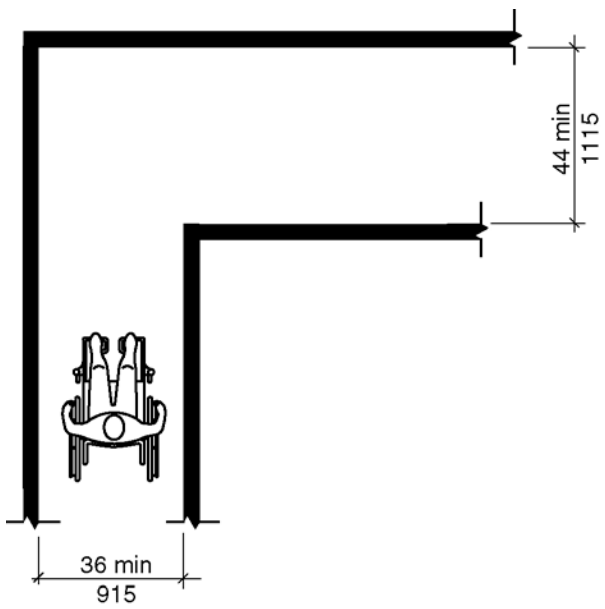
(b)  
Option 2

Figure 403.5.3.1(b) - Clear width at 90 degree turn – new buildings – Option 2



(c)  
Option 3

Figure 403.5.3.1(c) - Clear width at 90 degree turn – new buildings – Option 3



(d)  
Option 4

Figure 403.5.3.1(d) - Clear width at 90 degree turn – new buildings – Option 4

**403.5.3.2 Existing buildings and within Type B units.** In existing buildings and within new Type B units, where an accessible route makes a 90 degree turn the clear widths approaching the turn and leaving the turn shall be 36 inches (915 mm) minimum. (3-6-12 PC2)(ed.)

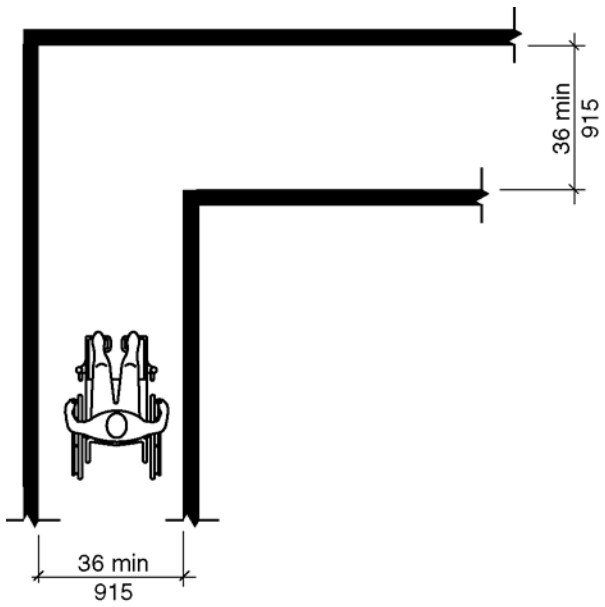


Figure 403.5.3.2 - Clear width at 90 degree turn – existing buildings

**403.5.4 Passing Space.**

**403.5.4.1 New construction.** In new buildings, an accessible route with a clear width less than 60 inches (1525 mm) shall provide passing spaces at intervals of 200 feet (61 m) maximum. Passing spaces shall be either a 60-inch (1525 mm) minimum by 60-inch (1525 mm) minimum space, or an intersection of two walking surfaces that provide a T-shaped turning space complying with Section 304.3.2.1, provided the base and arms of the T-shaped space extend 52 inches (1320 mm) minimum beyond the intersection. (4-6-12) (4-5-12)

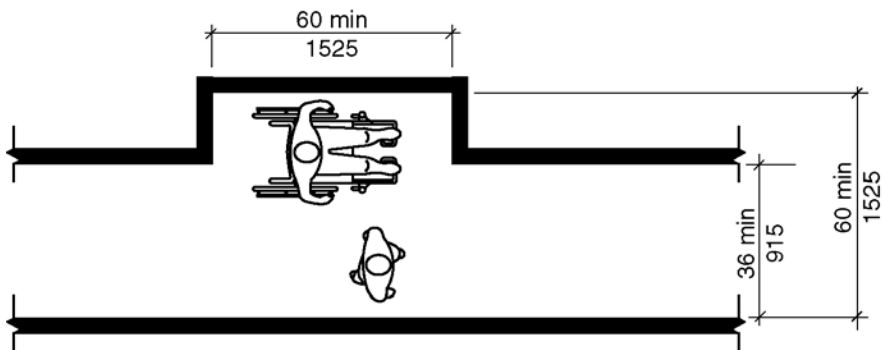


Figure 403.5.4.1(a) - Passing space – new buildings 60x60 option

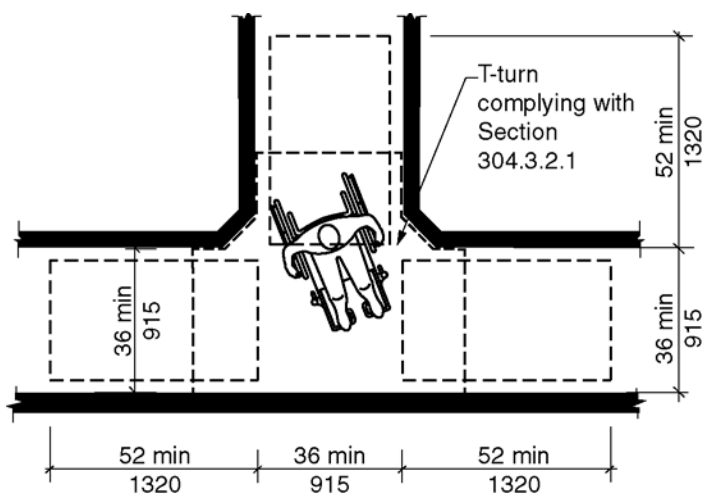


Figure 403.5.4.1(b) - Passing space – new buildings - T-turn option

**403.5.4.2 Existing buildings and within new Type B units.** In existing buildings and within new Type B units, an accessible route with a clear width less than 60 inches (1525 mm) shall provide passing spaces at intervals of 200 feet (61 m) maximum. Passing spaces shall be either a 60-inch (1525 mm) minimum by 60-inch (1525 mm) minimum space, or an intersection of two walking surfaces that provide a T-shaped turning space complying with Section 304.3.2.2, provided the base and arms of the T-shaped space extend 48 inches (1220 mm) minimum beyond the intersection. (3-6-12 PC2) (ETG 8-9-16) (ed.)

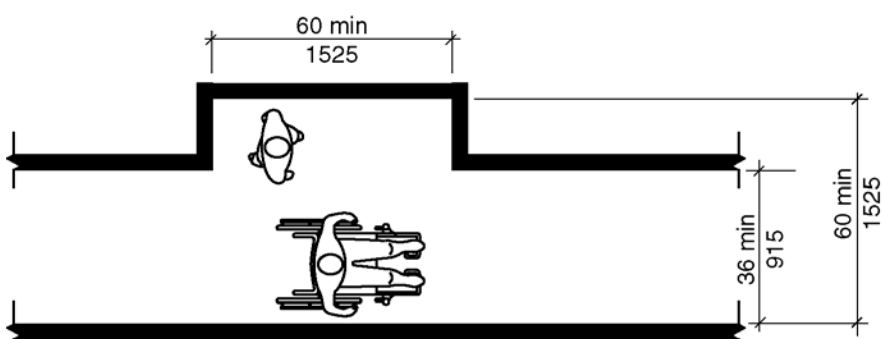


Figure 403.5.4.2(a) - Passing space – existing buildings - 60x60 option

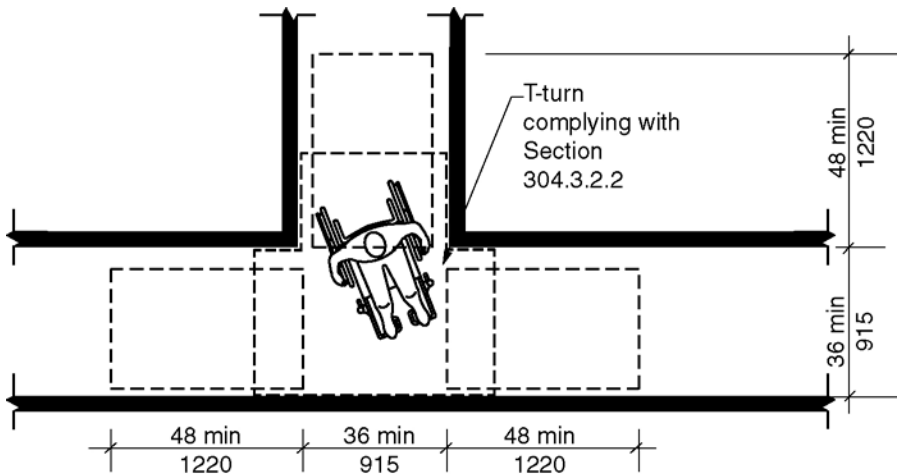


Figure 403.5.4.2(b) - Passing space – existing buildings - T-turn option

**403.6 Handrails.** Where handrails are required at the side of a corridor they shall comply with Sections 505.4 through 505.9.

#### 404 Doors, Doorways and Gates

**404.1 General.** Doors, and doorways and gates that are part of an accessible route shall comply with Section 404. (4-11-12)

**EXCEPTION:** Doors, doorways, and gates designed to be operated only by security personnel shall not be required to comply with Sections 404.2.3, 404.2.6, 404.2.7, 404.2.8, 404.3.2 and 404.3.4 through 404.3.6. (4-11-12)

**404.2 Manual Doors, Doorways and Manual Gates.** Manual doors and doorways, and manual gates, intended for user passage, shall comply with Section 404.2. (4-11-12)

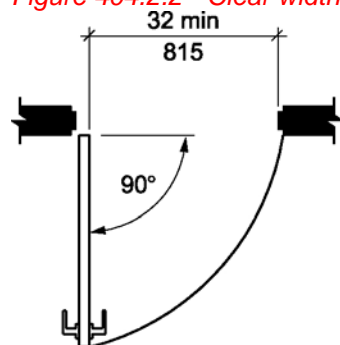
**404.2.1 Double-Leaf Doors and Gates.** At least one of the active leaves of doorways with two leaves shall comply with Sections 404.2.2 and 404.2.3.

**404.2.2 Clear Width.** Doorways shall have a clear opening width of 32 inches (815 mm) minimum. Clear opening width of doorways with swinging doors shall be measured between the face of door and stop, with the door open 90 degrees. Openings more than 24 inches (610 mm) in depth at doors and doorways without doors shall provide a clear opening width of 36 inches (915 mm) minimum. There shall be no projections into the clear opening width lower than 34 inches (865 mm) above the floor. Projections into the clear opening width between 34 inches (865 mm) and 80 inches (2030 mm) above the floor shall not exceed 4 inches (100 mm).

#### EXCEPTIONS:

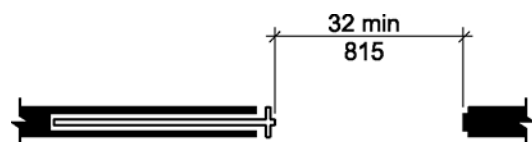
1. Door closers and door stops shall be permitted to be 78 inches (1980 mm) minimum above the floor.
2. In alterations, a projection of  $\frac{5}{8}$  inch (16 mm) maximum into the required clear opening width shall be permitted for the latch side stop.

*Figure 404.2.2 - Clear width of doorways*

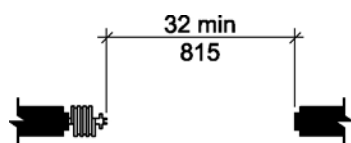
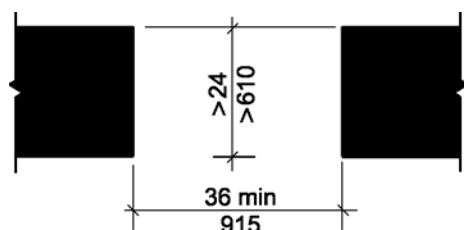


**(a) Hinged Door**

*A) hinged door*



**(b) Sliding Door**

*b) sliding door***(c) Folding Door***c) folding door***(d) Doorways without Doors***d) doorways without doors*

**404.2.3 Maneuvering Clearances.** Minimum maneuvering clearances at doors and gates shall comply with Section 404.2.3. Maneuvering clearances shall include the full clear opening width of the doorway and the required latch side or hinge side clearance. (4-11-12) (4-13-12)

**404.2.3.1 Floor Surface.** Floor surface within the maneuvering clearances shall have a slope not steeper than 1:48 and shall comply with Section 302.

**404.2.3.2 Swinging Doors and Gates.** Swinging doors and gates shall have maneuvering clearances complying with Table 404.2.3.2. (4-11-12)

**Table 404.2.3.2**  
**Maneuvering Clearances at Manual Swinging Doors and Gates**

TYPE OF USE		MINIMUM MANEUVERING CLEARANCES	
Approach Direction	Door or Gate Side	Perpendicular to Doorway	Parallel to Doorway (beyond latch unless noted)
From front	Pull	60 inches (1525 mm)	18 inches (455 mm)
From front	Push	52 inches (1320 mm) <sup>4</sup>	0 inches (0 mm) <sup>3</sup>
From hinge side	Pull	60 inches (1525 mm)	36 inches (915 mm)
From hinge side	Pull	54 inches (1370 mm)	42 inches (1065 mm)
From hinge side	Push	42 inches (1065 mm) <sup>1</sup>	22 inches (560 mm) <sup>3</sup>
From latch side	Pull	48 inches (1220 mm) <sup>2</sup>	24 inches (610 mm)
From latch side	Push	42 inches (1065 mm) <sup>2</sup>	24 inches (610 mm)

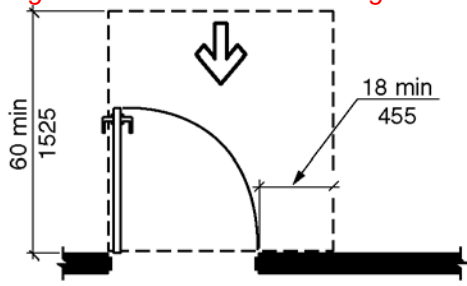
1. Add 6 inches (150 mm) if closer and latch provided.

2. Add 6 inches (150 mm) if closer provided.

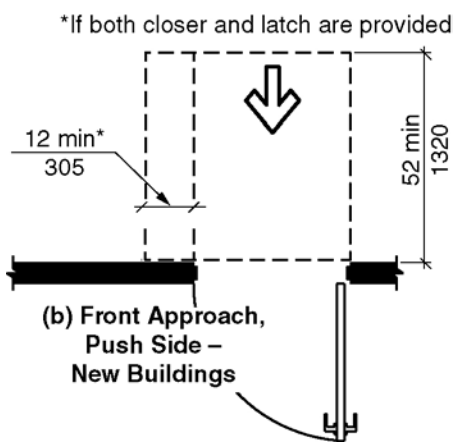
3. Beyond hinge side. (4-11-12) (4-14-12)(4-15-12)

4. In existing buildings and within new Type B buildings the dimension perpendicular to the door for the front direction on the push side shall be 48 inches (122 mm) minimum. (3-6-12 PC2) (ed.)

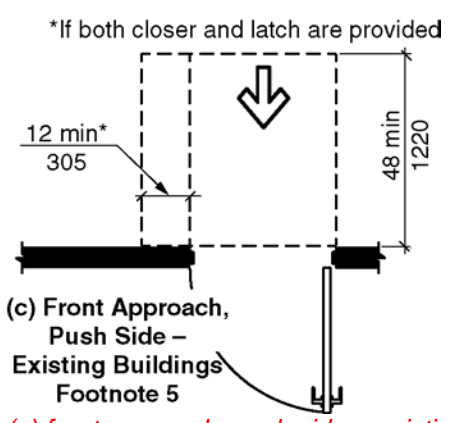
Figure 404.2.3.2 – Maneuvering clearance at manual swinging doors



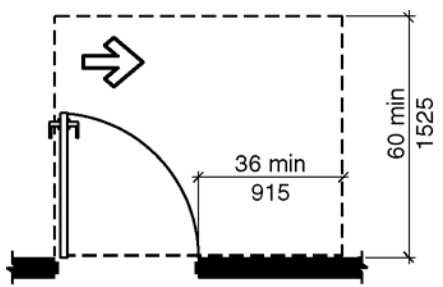
(a) Front Approach, Pull Side  
*(a) front approach, pull side*



*(b) front approach, push side – new buildings*

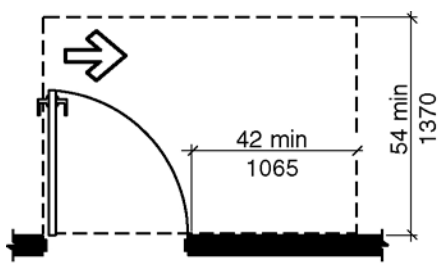


*(c) front approach, push side – existing buildings – Footnote 5*



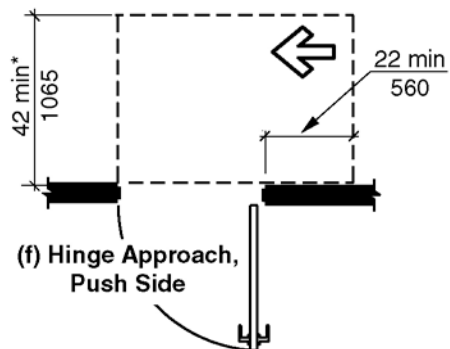
(d) Hinge Approach, Pull Side  
*(d) hinge approach, pull side*





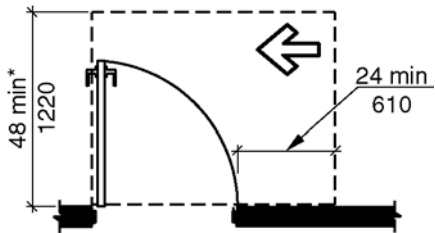
(e) Hinge Approach, Pull Side  
 (e) hinge approach, pull side

\* 48 min (1220) if both closer and latch provided

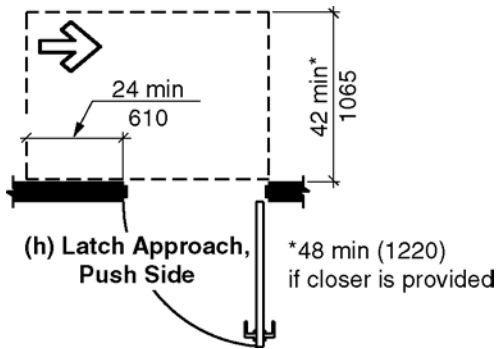


(f) Hinge Approach, Push Side  
 (f) hinge approach, push side

\*54 min (1370) if closer if provided



(g) Latch Approach, Pull Side  
 (g) latch approach, pull side



(h) Latch Approach, Push Side  
 (h) latch approach, push side

\*48 min (1220) if closer is provided

**404.2.3.3 Sliding and Folding Doors.** Sliding doors and folding doors shall have maneuvering clearances complying with Table 404.2.3.3.

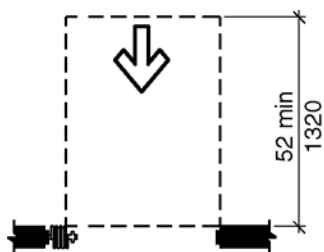
**Table 404.2.3.3—Maneuvering Clearances at Sliding and Folding Doors**

Approach Direction	MINIMUM MANEUVERING CLEARANCES	
	Perpendicular to Doorway	Parallel to Doorway (beyond stop or latch side unless noted)
From front	52 inches (1320 mm) <sup>2</sup>	0 inches (0 mm)
From nonlatch side	42 inches (1065 mm)	22 inches (560 mm) <sup>1</sup>
From latch side	42 inches (1065 mm)	24 inches (610 mm)

<sup>1</sup>Beyond pocket or hinge side. (4-15-12)

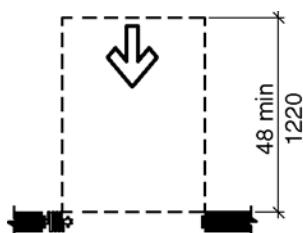
<sup>2</sup>In existing buildings and within new Type B buildings the dimension perpendicular to the door for the front direction shall be 48 inches (1220 mm) minimum. (3-6-12 PC2) (ed.)

*Figure 404.2.3.3 Maneuvering Clearances at Sliding and Folding Doors*



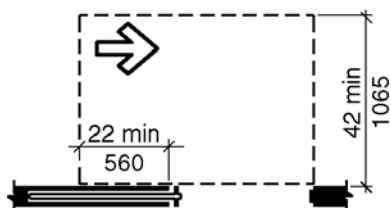
**(a) Front Approach**

*(a) front approach – new buildings*



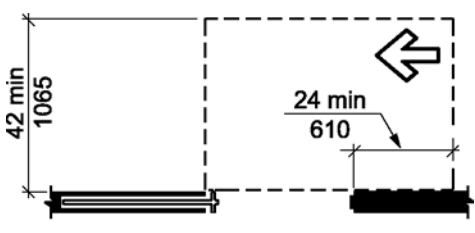
**(b) Front Approach –  
Existing Buildings –  
Footnote 2**

*(b) front approach – existing buildings – footnote 2*



**(c) Pocket or Hinge Approach**

*(c) pocket or hinge approach*



(d) Stop or Latch Approach  
 (d) stop or latch approach

**404.2.3.4 Doorways without Doors or Gates.** Doorways without doors or gates that are less than 36 inches (915 mm) in width shall have maneuvering clearances complying with Table 404.2.3.4. (4-11-12)

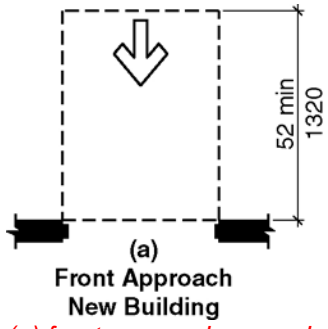
**Table 404.2.3.4—Maneuvering Clearances for Doorways without Doors**

Approach Direction	MINIMUM MANEUVERING CLEARANCES Perpendicular to Doorway
From front	52 inches (1320 mm) <sup>1</sup>
From side	42 inches (1065 mm)

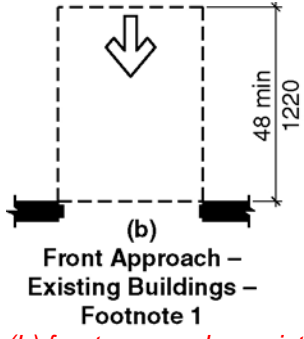
(4-15-12)

1. In existing buildings ~~and within new Type B buildings~~ the dimension perpendicular to the doorway for the front direction shall be 48 inches (1220 mm) minimum. (3-6-12 PC2) (ed.)

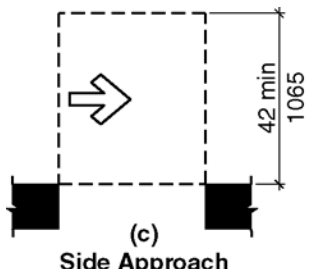
Figure 404.2.3.4 Maneuvering Clearances for Doorways without Doors or Gates



(a) front approach – new buildings



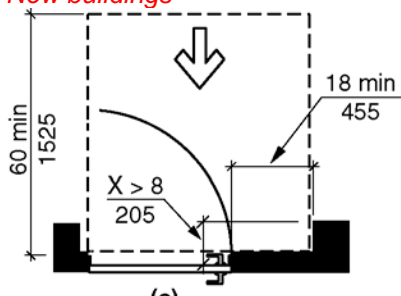
(b) front approach – existing buildings – footnote 1



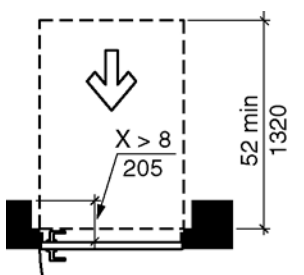
(c) Side Approach  
*(c) side approach*

**404.2.3.5 Recessed Doors and Gates.** Where any obstruction within 18 inches (455 mm) of the latch side of a doorway projects more than 8 inches (205 mm) beyond the face of the door or gate, measured perpendicular to the face of the door, maneuvering clearances for a forward approach shall be provided. (4-11-12)

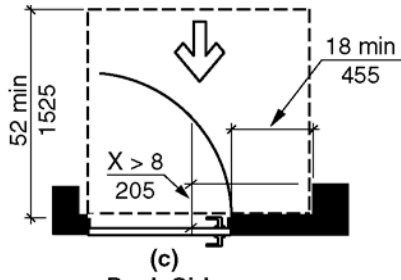
*404.2.3.5 Recessed doors and gates  
New buildings*



(a) Pull Side  
*(a) pull side*



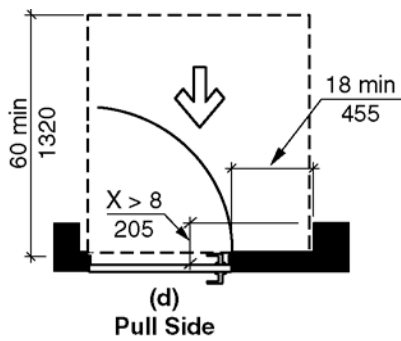
(b) Push Side  
*(b) push side*



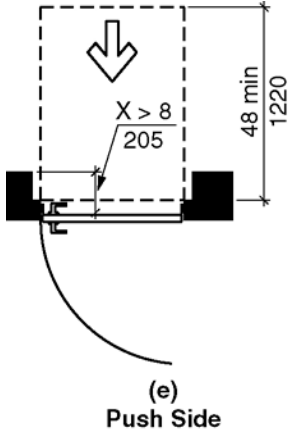
(c)  
Push Side  
Door provided with both  
closer and latch

*(c) push side, door provided with both closer and latch*

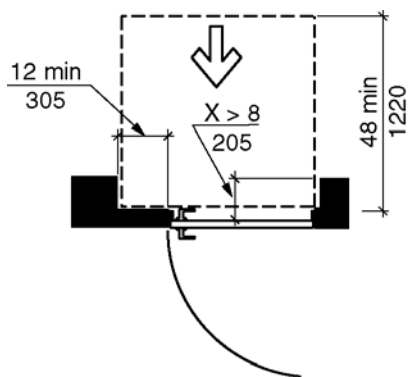
*Existing buildings*



(d)  
Pull Side  
*(d) pull side*



(e)  
Push Side  
*(e) push side*



(f)

**Push Side, Door Provided  
with Both Closer and Latch**

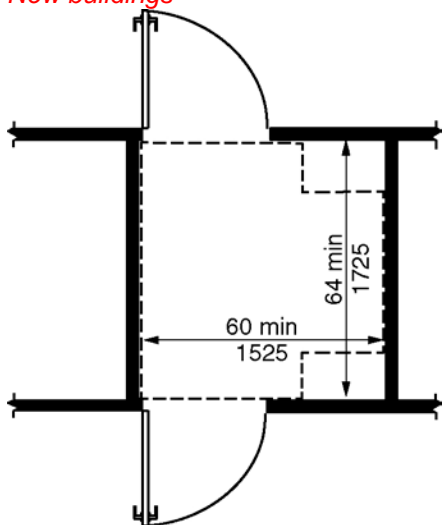
*(f) push side, door provided with both closer and latch*

**404.2.4 Thresholds.** Thresholds at doorways shall be  $\frac{1}{2}$  inch (13 mm) maximum in height. Raised thresholds and changes in level at doorways shall comply with Sections 302 and 303.

**EXCEPTION:** An existing or altered threshold shall be permitted to be  $\frac{3}{4}$  inch (19 mm) maximum in height provided that the threshold has a beveled edge on each side with a maximum slope of 1:2 for the height exceeding  $\frac{1}{4}$  inch (6.4 mm).

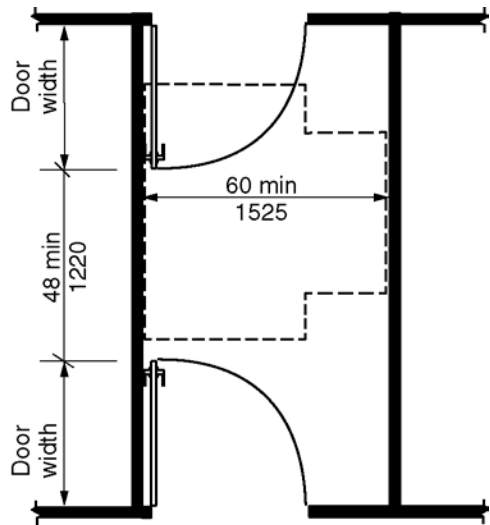
**404.2.5 Two Doors or Gates in Series.** Distance between two hinged or pivoted doors or gates in series shall be 48 inches (1220 mm) minimum plus the width of any door or gate swinging into the space. The space between the doors shall provide a turning space complying with Section 304. (4-11-12) (ed.)

*Figure 404.2.5 Two doors or gates in a series  
New buildings*



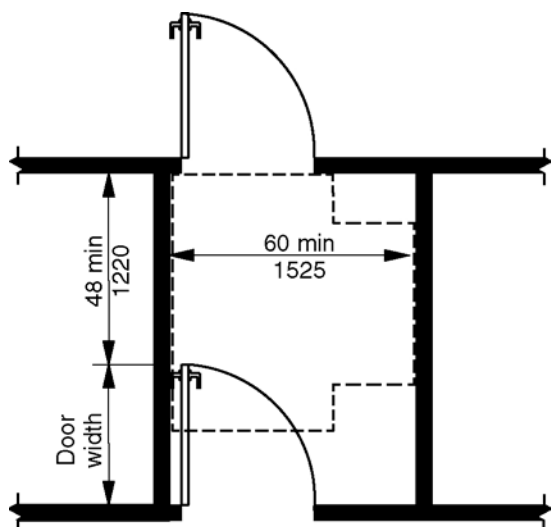
(a)

*(a) both doors opening out from the vestibule*



(b)

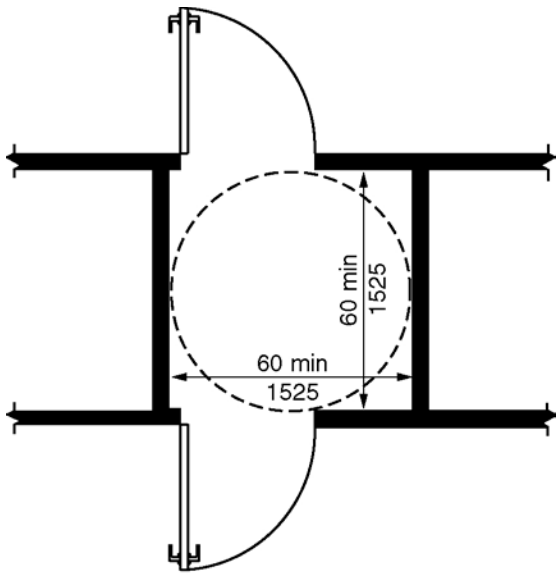
*(b) both doors opening into the vestibule*



(c)

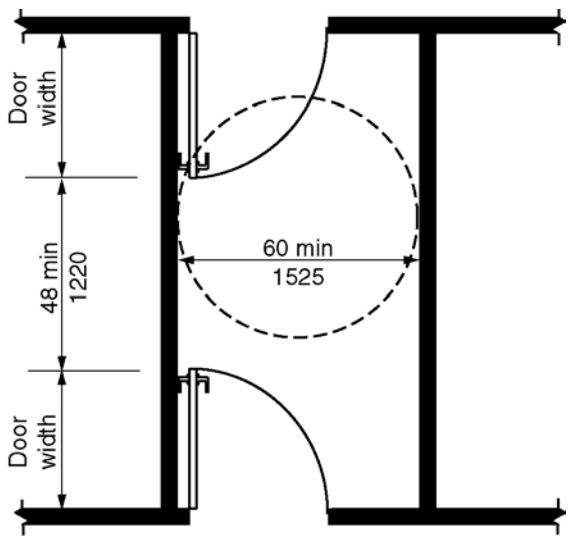
*(c) both doors opening in the same direction of travel*

*Existing buildings*



(d)

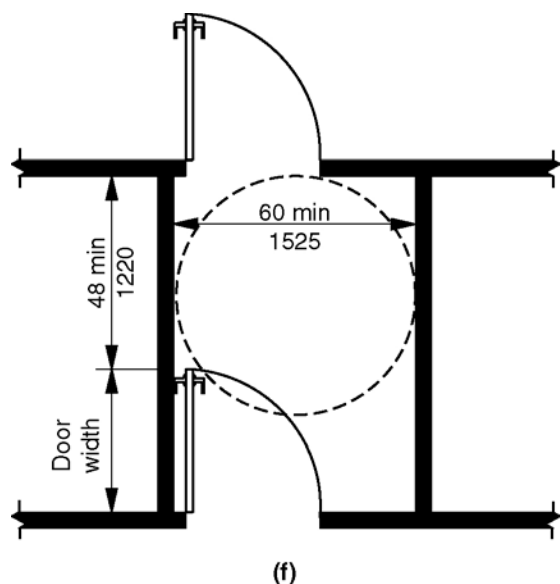
*(d) both doors opening out from the vestibule*



(e)

*(e) both doors opening into the vestibule*





(f) both doors opening in the same direction of travel

**\*\*404.2.6 Door and Gate Hardware.** Handles, pulls, latches, locks, and other operable parts on accessible doors and gates shall have a shape that is easy to grasp with one hand and does not require tight grasping, pinching, or twisting of the wrist to operate. The operational force to retract latches or disengage devices that hold the door in a closed position shall be as follows: (ed.)

1. Hardware operation by a forward, pushing or pulling motion: 15 pounds (66.7 N) maximum
2. Hardware operation by a rotational motion: 28 inch-pounds (315 N-cm) maximum. (4-23-12 PC1)

**EXCEPTION:** The 5.0 pounds force to retract latch bolts or disengage other devices that hold the door or gate in a closed position shall not apply to panic hardware, delayed egress devices or fire-rated hardware. (4-23-12)(7-5-16)

**404.2.6.1 Hardware height.** Operable parts of such hardware shall be 34 inches (865 mm) minimum and 48 inches (1220 mm) maximum above the floor. Where sliding doors are in the fully open position, operating hardware shall be exposed and usable from both sides. (4-11-12) (ed.)

**404.2.7 Closing Speed.** Door and gate closing speed shall comply with 404.2.7. (4-11-12)

**404.2.7.1 Door Closers and Gate Closers.** Door closers and gate closers shall be adjusted so that from an open position of 90 degrees, the time required to move the door to an open position of 12 degrees shall be 5 seconds minimum. (4-11-12)

**404.2.7.2 Spring Hinges.** Door and gate spring hinges shall be adjusted so that from an open position of 70 degrees, the door or gate shall move to the closed position in 1.5 seconds minimum. (4-11-12)

**\*\*404.2.8 Door and Gate-Opening Force.** Fire doors and doors required to be equipped with panic hardware, break away features or other factors requiring higher opening force for safety reasons shall have the minimum opening force allowable in scoping provisions adopted by the appropriate administrative authority. For other doors, the force for pushing or pulling open doors or gates shall be as follows: (4-23-12) (4-11-12)(4-23-12 PC1)

1. Interior hinged doors and gates: 5.0 pounds (22.2 N) maximum. (4-11-12)

2. Sliding or folding doors: 5.0 pounds (22.2 N) maximum.

~~Opening forces for exterior sliding doors shall be determined in accordance with AAMA 513 listed in Section 106.2.13. (4-23-12 PC2)~~

**EXCEPTION:** The 5.0 pounds force to retract latch bolts or disengage other devices that hold the door or gate in a closed position shall not apply to panic hardware, delayed egress devices or fire-rated hardware. (4-23-12)(7-5-16)

**404.2.9 Door and Gate Surface.** Door and gate surfaces within 10 inches (255 mm) of the floor, measured vertically, shall be a smooth surface on the push side extending the full width of the door or gate. Door and gate hardware, or any other obstruction or protrusion shall not be mounted in nor extend into the area within 10 inches (255 mm) of the floor. Parts creating horizontal or vertical joints in the smooth surface shall be within  $\frac{1}{16}$  inch (1.6 mm) of the same plane as the other. Cavities created by added kick plates shall be capped. (4-27-12) (4-11-12)

**EXCEPTIONS:**

1. Sliding doors shall not be required to comply with ~~Section 404.2.9~~ this section. (ed.)
2. Tempered glass doors without stiles and having a bottom rail or shoe with the top leading edge tapered at no less than 60 degrees from the horizontal shall not be required to comply with the 10-inch (255 mm) bottom rail height requirement.
3. Doors and gates that do not extend to within 10 inches (255 mm) of the floor shall not be required to comply with ~~Section 404.2.9~~ this section. (4-11-12) (ed.)
4. The installation of kick plates on existing doors and gates without a smooth surface within 10 inches (255 mm) of the floor shall be permitted. The kick plates shall extend to 10 inches (255 mm) above the floor and no more than 1 inch (26 mm) from the sides and bottom of the door. Cavities created by such kickplates shall be capped. (4-29-12)

**404.2.10 Vision Lites.** Doors, gates and sidelites adjacent to doors or gates containing one or more glazing panels that permit viewing through the panels shall have the bottom of at least one panel on either the door or an adjacent sidelite 43 inches (1090 mm) maximum above the floor. (4-11-12)

**EXCEPTION:** Vision lites with the lowest part more than 66 inches (1675 mm) above the floor shall not be required to comply with ~~Section 404.2.10~~ this section. (ed.)

**404.3 Automatic Doors and Power-Assisted Doors and Gates.** Automatic doors and automatic gates shall comply with Section 404.3. Full powered automatic doors and gates shall comply with ANSI/BHMA A156.10 listed in Section 106.2.8. Power-assist doors and gates and low-energy automatic doors and gates shall comply with ANSI/BHMA A156.19 listed in Section 106.2.7 (4-11-12) (4-30-12) (4-31-12 PC1)

**404.3.1 Public Entrances.** Where an automatic door is required at a building or facility public entrance, it shall be a full powered automatic door or a low-energy automatic door. (4-33-12 PC1.1) (ed.)

**404.3.2 Vestibules.** Where ~~the~~ an entrance includes a vestibule at least one exterior door and one interior door in the vestibule shall have the same type of automatic door opener. (4-33-12 PC1.1)

**404.3.3 Clear Width.** Doorways shall have a clear opening width of 32 inches (815 mm) in power-on and power-off mode. The minimum clear opening width for automatic door systems shall be based on the clear opening width provided with all leaves in the open position.

**404.3.4 Maneuvering Clearances.** Maneuvering clearances at power-assisted doors and gates shall comply with Section 404.2.3. Maneuvering clearances complying with Section 404.2.3 shall be provided

on the egress side of low-energy automatic doors and gates and full power automatic doors and gates that serve as part of the **accessible** means of egress. (4-30-12 PC1)(4-11-12)(4-31-12 PC1)

#### EXCEPTIONS:

1. Low-energy automatic doors and gates and full power automatic doors and gates that have standby power or battery back-up shall not be required to comply with this section.
2. Low-energy automatic doors and gates and full power automatic doors and gates that remain open in the power-off condition shall not be required to comply with this section.
3. Full power automatic sliding doors and gates that include a break-away feature shall not be required to comply with this section.(4-31-12 PC1)

**404.3.5 Thresholds.** Thresholds and changes in level at doorways shall comply with Section 404.2.4.

**404.3.6 Two Doors or Gates in Series.** Doors or gates in series shall comply with Section 404.2.5. (4-11-12)

**EXCEPTION:** Where both doors or gates in a series are ~~power-assist doors~~, low energy automatic doors or full power automatic doors, the two doors and gates in a series shall not be required to provide a turning space between the doors. (4-34-12 PC1.1)(4-34-12/1.1-PC1.1 Agenda item #13.1)

**404.3.7 Controls.** Manually operated controls shall comply with Section 309. The clear floor space adjacent to the control shall be located beyond the arc of door swings. (4-34-12) (4-30-12)(4-31-12)

**404.3.8 Door and Gate Hardware.** Handles, pulls, latches, locks, and other operable parts shall comply with Section 404.2.6. (4-34-12)

**404.3.9 Break Out Opening.** Where full power automatic sliding doors and gates are equipped with a break out feature, the clear break out opening shall be 32 inches (815 mm) minimum when operated in emergency mode. (4-31-12)

#### 405 Ramps

**405.1 General.** Ramps along accessible routes shall comply with Section 405.

**EXCEPTION:** In assembly areas, aisle ramps adjacent to seating and not serving elements required to be on an accessible route shall not be required to comply with Section 405.

**405.2 Slope.** Ramp runs shall have a running slope greater than 1:20 and not steeper than 1:12.

**EXCEPTION:** In existing buildings or facilities, ramps shall be permitted to have slopes steeper than 1:12 complying with Table 405.2 where such slopes are necessary due to space limitations.

**Table 405.2—Allowable Ramp Dimensions for Construction in Existing Sites, Buildings, and Facilities**

Slope <sup>1</sup>	Maximum Rise
Steeper than 1:10 but not steeper than 1:8	3 inches (75 mm)
Steeper than 1:12 but not steeper than 1:10	6 inches (150 mm)

<sup>1</sup>A slope steeper than 1:8 shall not be permitted.

**405.3 Cross Slope.** Cross slope of ramp runs shall not be steeper than 1:48.

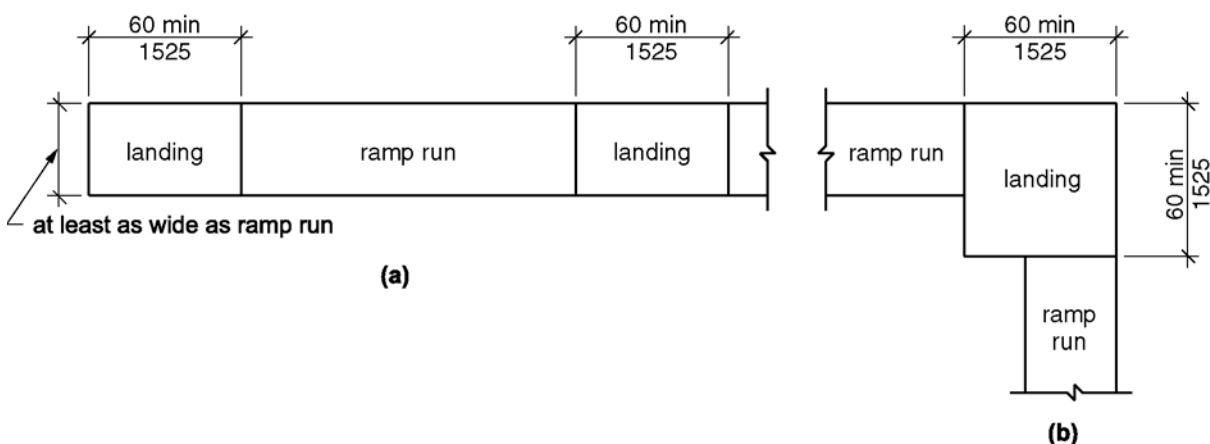
**405.4 Floor Surfaces.** Floor surfaces of ramp runs shall comply with Section 302.

**405.5 Clear Width.** The clear width of a ramp run shall be 36 inches (915 mm) minimum. Handrails and handrail supports that are provided on the ramp run shall not project into the required clear width of the ramp run.

**EXCEPTION:** Within employee work areas, the required clear width of ramps that are a part of common use circulation paths shall be permitted to be decreased by work area equipment provided that the decrease is essential to the function of the work being performed. (4-38-12)

**405.6 Rise.** The rise for any ramp run shall be 30 inches (760 mm) maximum.

**405.7 Landings.** Ramps shall have landings at the bottom and top of each ramp run. Landings shall comply with Section 405.7.



*Figure 405.7 Ramp landings*

**405.7.1 Slope.** Landings shall have a slope not steeper than 1:48 and shall comply with Section 302.

**405.7.2 Width.** Clear width of landings shall be at least as wide as the widest ramp run leading to the landing.

**405.7.3 Length.** Landings shall have a clear length of 60 inches (1525 mm) minimum.

**405.7.4 Change in Direction.** Ramps that change direction between runs at landings shall have a clear landing 60 inches (1525 mm) minimum by 60 inches (1525 mm) minimum. (4-40-12)

**405.7.5 Doorways.** Where doorways are adjacent to a ramp landing, maneuvering clearances required by Sections 404.2.3 and 404.3.2 shall be permitted to overlap the landing area. Where a door that is subject to locking is located adjacent to a ramp landing, the landing shall be sized to provide a turning space complying with Section 304.3.

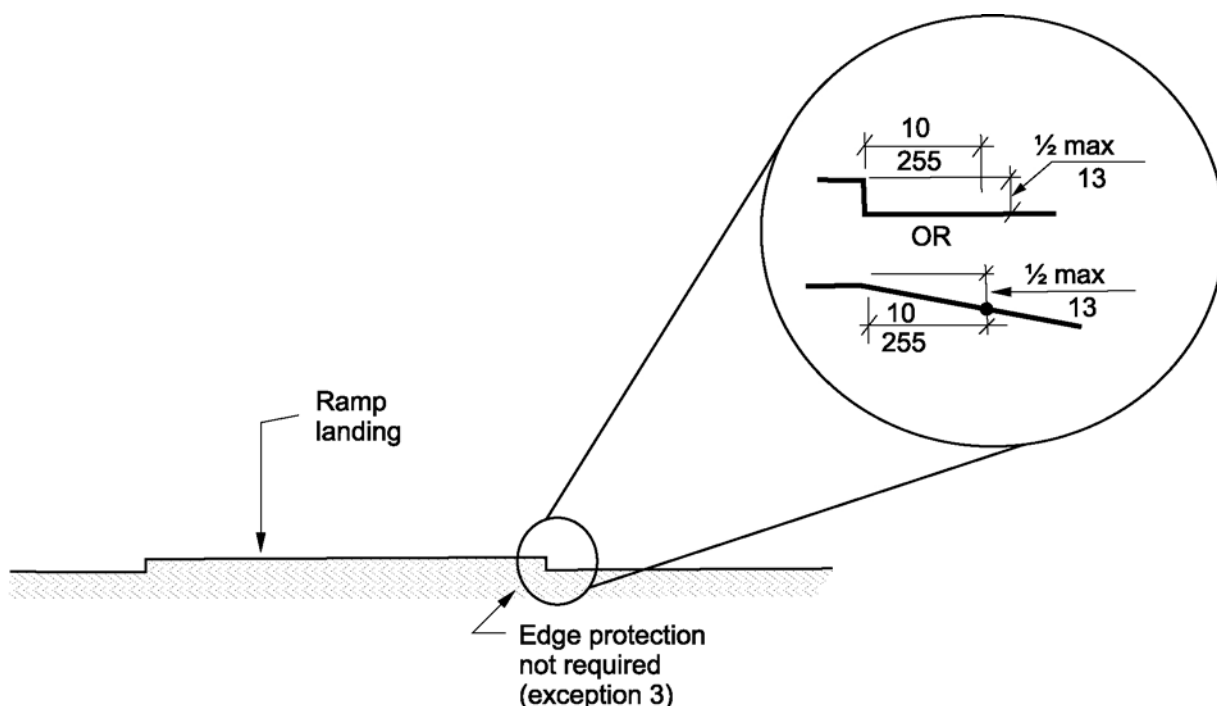
**405.8 Handrails.** Ramp runs with a rise greater than 6 inches (150 mm) shall have handrails complying with Section 505.

**EXCEPTION:** Within employee work areas, handrails shall not be required where ramps that are part of common use circulation paths, and which are used for the movement of equipment, are designed to permit the installation of handrails complying with 505. Ramps not subject to the exception to Section 405.5 shall be designed to maintain a 36 inch (915 mm) minimum clear width where handrails are installed. (4-38-12)

**405.9 Edge Protection.** Edge protection complying with Section 405.9.1 or 405.9.2 shall be provided on each side of ramp runs and at each side of ramp landings.

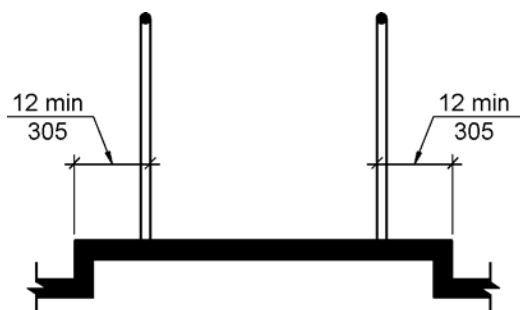
**EXCEPTIONS:**

1. Edge protection shall not be required on ramps not required to have handrails and that have flared sides complying with Section 406.3.
2. Edge protection shall not be required on the sides of ramp landings serving an adjoining ramp run or stairway.
3. Edge protection shall not be required on the sides of ramp landings having a vertical drop-off of  $\frac{1}{2}$  inch (13 mm) maximum within 10 inches (255 mm) horizontally of the minimum landing area specified in Section 405.7.
4. Edge protection shall not be required on the sides of ramped aisles where the ramps provide access to the adjacent seats and aisle access ways.



*Figure 405.9 Edge protection – limited drop off – Exception 3*

**405.9.1 Extended Floor Surface.** The floor surface of the ramp run or ramp landing shall extend 12 inches (305 mm) minimum beyond the inside face of a railing complying with Section 505.

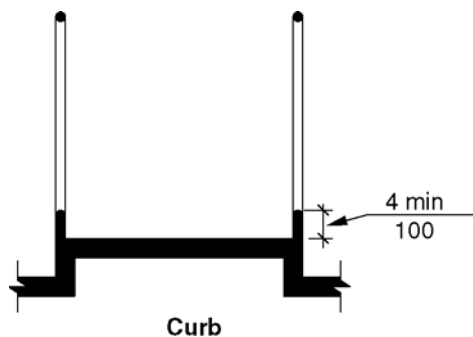


*Figure 405.9.1 Extended floor surface*

**405.9.2 Curb or Barrier.** A curb complying with Section 405.9.2.1 or a barrier complying with Section

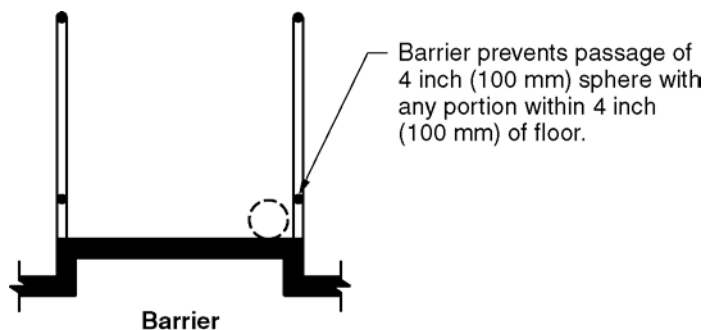
405.9.2.2 shall be provided.

**405.9.2.1 Curb.** A curb shall be a minimum of 4 inches (100 mm) in height.



*Figure 405.9.2.1 Curb*

**405.9.2.2 Barrier.** Barriers shall be constructed so that the barrier prevents the passage of a 4-inch (100 mm) diameter sphere where any portion of the sphere is within 4 inches (100 mm) of the floor.



*Figure 405.9.2.2 Barrier*

**405.10 Wet Conditions.** Landings subject to wet conditions shall be designed to prevent the accumulation of water.

#### **406 Curb Ramps and Blended Transitions (4-42-12)**

**406.1 General.** Curb ramps and blended transitions on accessible route shall comply with Section 406. (4-42-12)

**406.2 Perpendicular Curb Ramps.** Perpendicular curb ramps shall comply with Sections 406.2 and 406.5. (4-42-12)

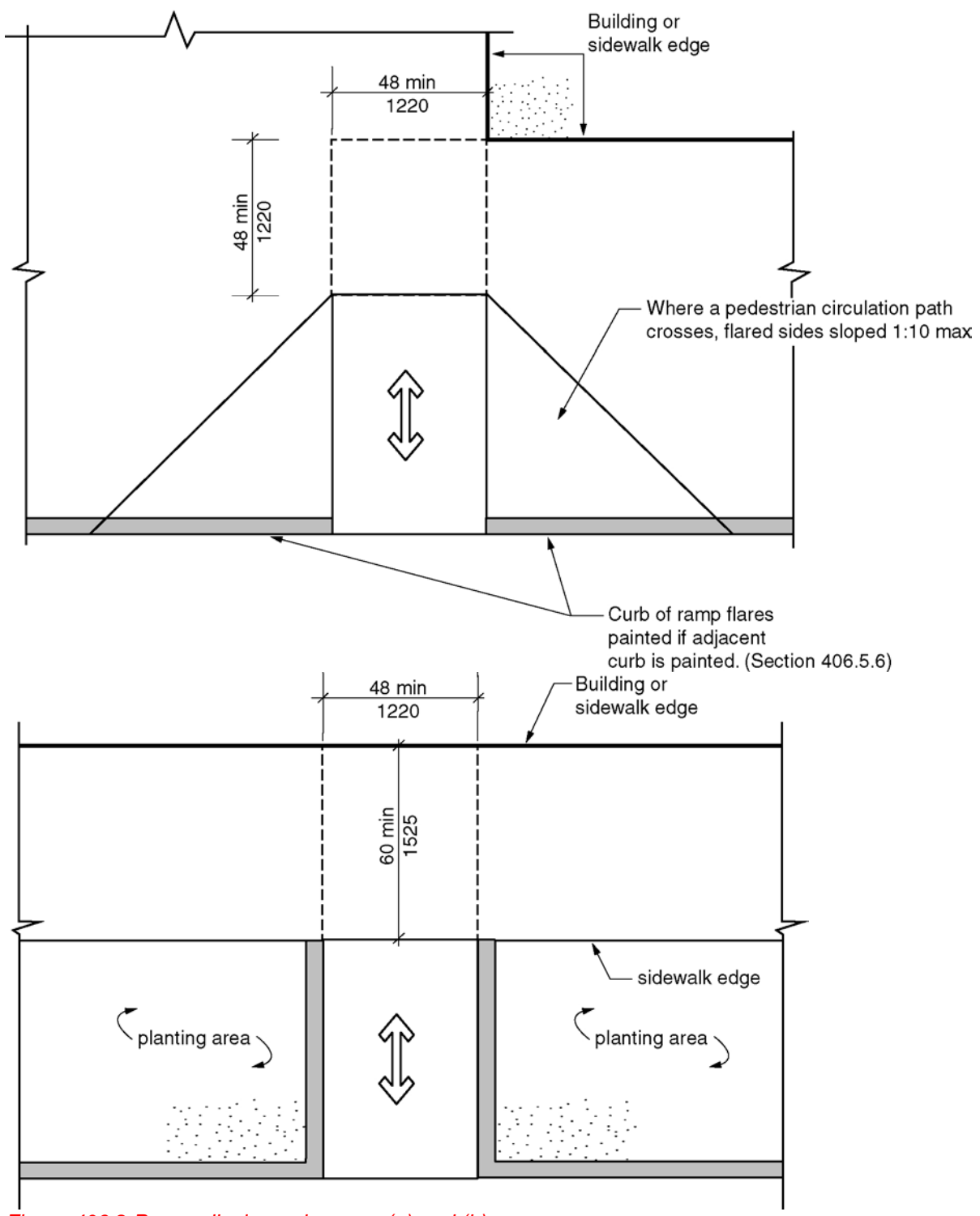


Figure 406.2 Perpendicular curb ramps (a) and (b)

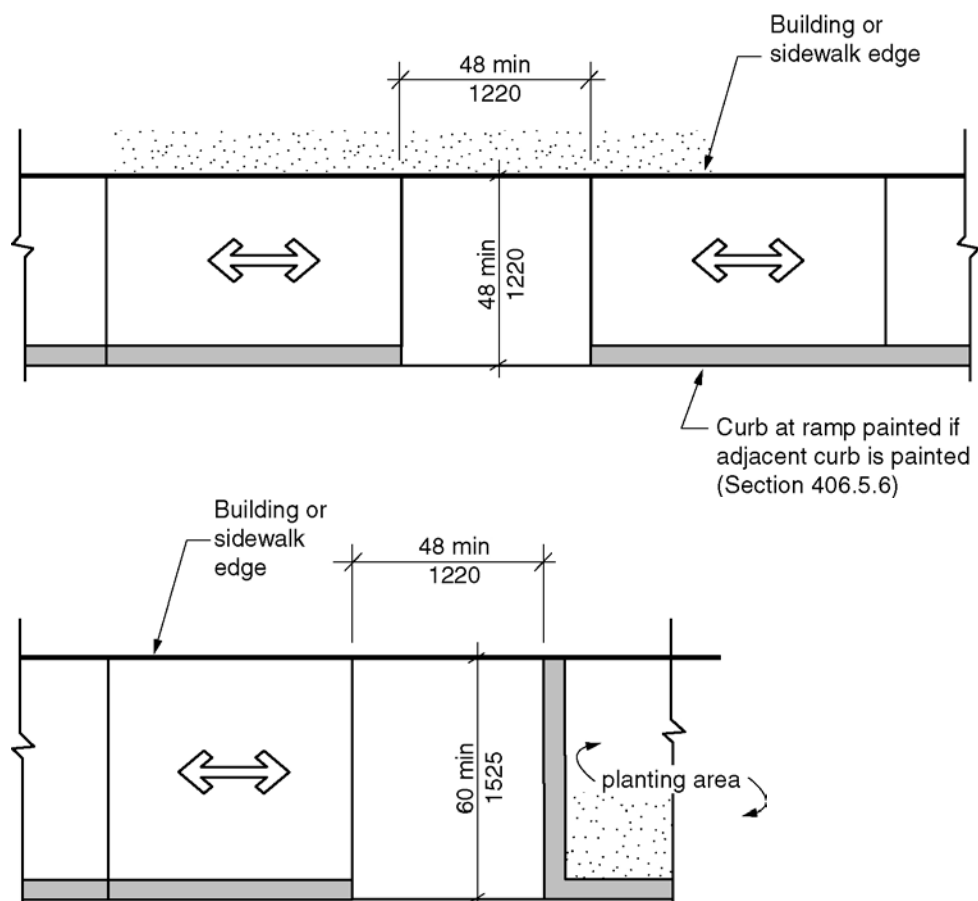
**406.2.1 Landing.** A landing 48 inches (1220 mm) minimum by 48 inches (1220 mm) minimum shall be provided at the top of the curb ramp and shall be permitted to overlap pedestrian routes and clear spaces. Where the turning space is constrained at the back-of-sidewalk, the landing shall be 48 inches (1220 mm) minimum by 60 inches (1525 mm) minimum. The 60 inches (1525 mm) dimension shall be provided in the

direction of the curb ramp run. The slope of the landing shall be 1:48 maximum in all directions. **(4-42-12) (4-42-12 PC1 and PC4)**

**406.2.2 Running Slope.** The running slope of the curb ramp shall cut through or shall be built up to the curb at right angles or shall meet the gutter grade break at right angles where the curb is curved. The running slope of the curb ramp shall be 1:20 minimum and 1:12 maximum. The curb ramp run length shall not be required to exceed 15 feet (4570 mm). **(4-42-12) (4-42-12 PC1 and PC4)**

**406.2.3 Flared Sides.** Where a pedestrian circulation path crosses the curb ramp, flared sides shall be provided and shall be sloped 10 percent maximum. **(4-42-12 PC3)**

**406.3 Parallel Curb Ramps.** Parallel curb ramps shall comply with Sections 406.3 and 406.5. **(4-42-12)**



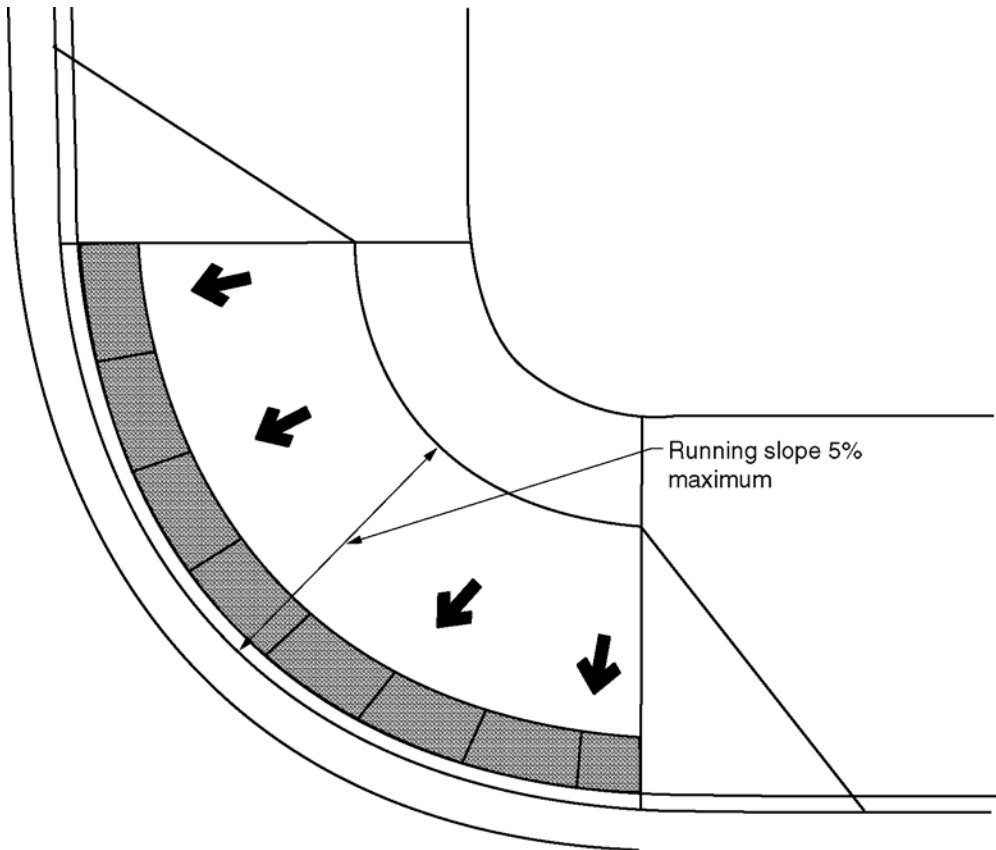
**Figure 406.3 Parallel curb ramps (a) and (b)**

**406.3.1 Landing.** A landing 48 inches (1220 mm) minimum by 48 inches (1220 mm) minimum shall be provided at the bottom of the curb ramp and shall be permitted to overlap pedestrian routes and clear spaces. Where the landing is constrained on 2 or more sides, the landing shall be 48 inches (1220 mm) minimum by 60 inches (1525 mm) minimum. The 60 inches (1525 mm) dimension shall be provided in the direction of the pedestrian street crossing. The slope of the landing shall be 1:48 maximum in all directions. **(4-42-12) (4-42-12 PC4)**

**406.3.2 Running Slope.** The running slope of the curb ramp shall be in-line with the direction of sidewalk travel. The running slope of the curb ramp shall be 1:20 minimum and 1:12 maximum. The curb ramp run length shall not be required to exceed 15 feet (4570 mm). minimum. **(4-42-12) (4-42-12 PC1 and PC4)**

**406.4 Blended Transitions.** Blended transitions shall comply with Sections 406.4 and 406.5. **(4-42-12)**





*Figure 406.4 Blended transitions*

**406.4.1 Running Slope.** The running slope of blended transitions shall be 1:20 maximum. (4-42-12)

**406.5 Common Requirements.** Curb ramps and blended transitions shall comply with Section 406.5. (4-42-12)

**406.5.1 Width.** The clear width of curb ramp runs (excluding any flared sides) and blended transitions shall be 48 inches (1220 mm) minimum. (4-42-12) (4-42-12 PC4)

**406.5.2 Grade Breaks.** Grade breaks at the top and bottom of curb ramp runs shall be perpendicular to the direction of the curb ramp run. Grade breaks shall not be permitted on the surface of curb ramp runs and landings. Surface slopes that meet at grade breaks shall be flush. (4-42-12) (4-42-12 PC1 and PC4) (ed.)

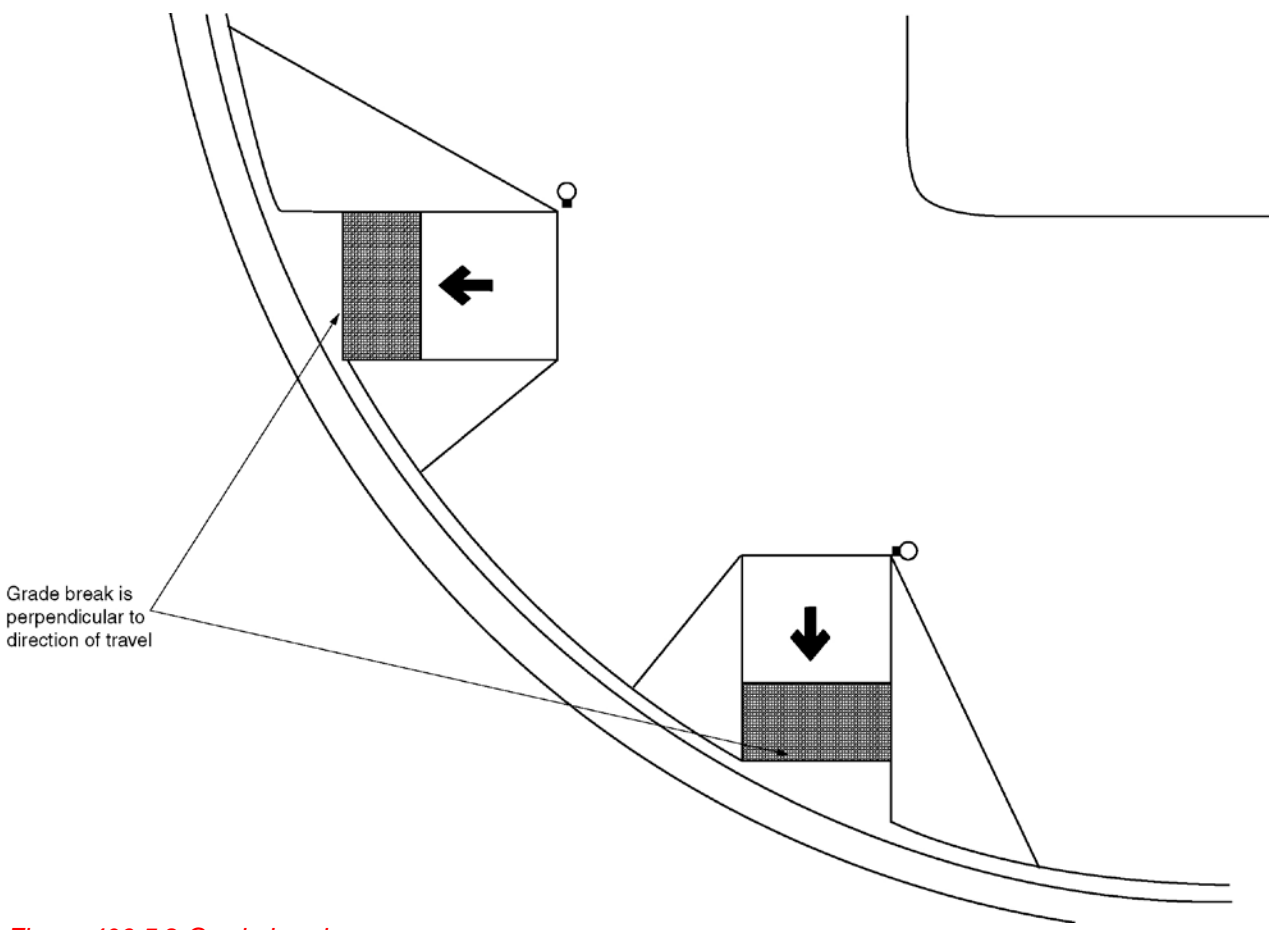


Figure 406.5.2 Grade break

**406.5.3 Cross Slope.** The cross slope of curb ramps, and blended transitions shall be 1:48 maximum. At pedestrian street crossings without yield or stop control and at midblock pedestrian street crossings, the cross slope shall be permitted to equal the street or highway grade. (4-42-12) (4-42-12 PC4)

**406.5.4 Counter Slope.** The counter slope of the gutter or street at the foot of curb ramp runs, blended transitions and landings shall be 1:20 maximum. (4-42-12) (4-42-12 PC4)

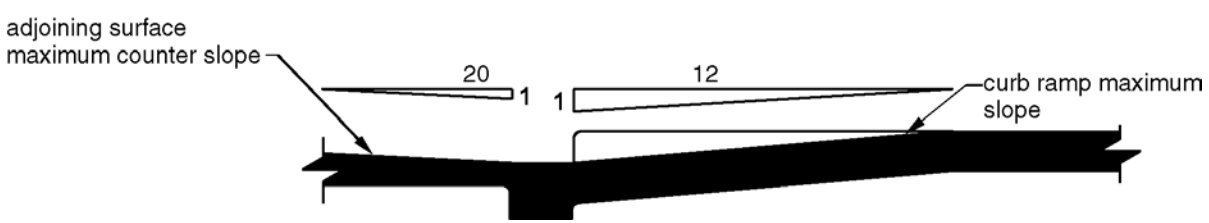
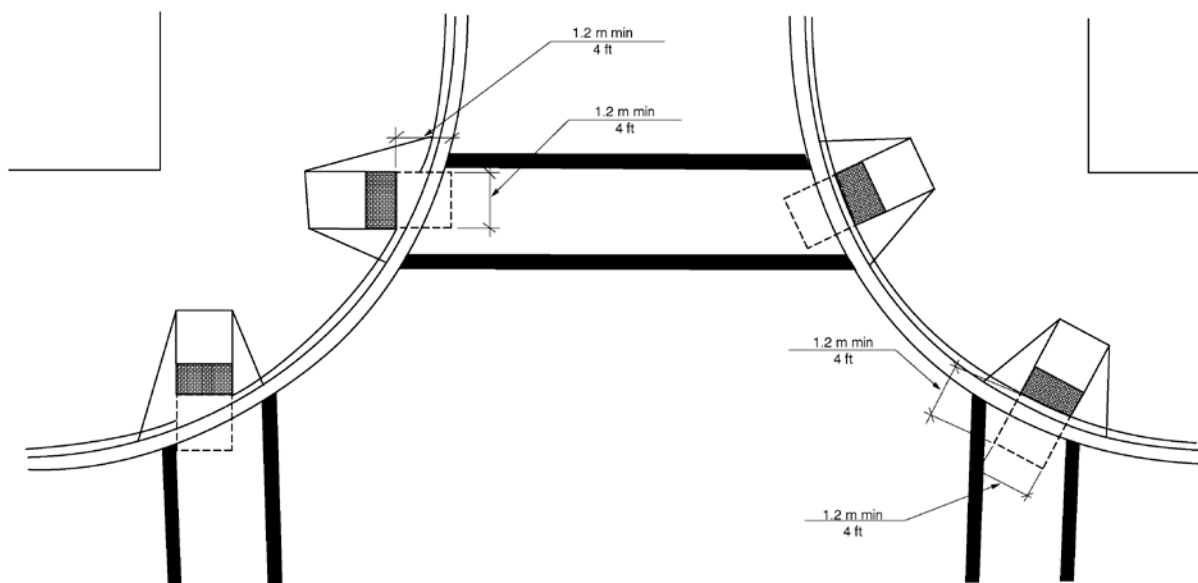


Figure 406.5.4 Counter slope of surface adjacent to curb ramps and blended transitions

**406.5.5 Clear Space.** Beyond the bottom grade break, a clear space 48 inches (1220 mm) minimum by 48 inches (1220 mm) minimum shall be provided within the width of the pedestrian street crossing and wholly outside the parallel vehicle travel lane. (4-42-12)



*Figure 406.5.5 Clear space a bottom of curb ramps and blended transitions.*

**406.5.6 Marking.** If curbs adjacent to the ramp flares are painted, the painted surface shall extend along the flared portion of the curb.

**406.5.7 Location.** Curb ramps and the flared sides of curb ramps shall be located so they do not project into vehicular traffic lanes, parking spaces, or parking access aisles. Curb ramps at marked crossings shall be wholly contained within the markings, excluding any flared sides.

**406.5.9 Obstructions.** Curb ramps shall be located or protected to prevent their obstruction by parked vehicles.

**406.5.10 Handrails.** Handrails shall not be required on curb ramps.

**406.6 Where Detectable Warnings are Required.** Where detectable warning surfaces are provided, they shall comply with Section 705. (4-44-12 PC3)

**406.7 Required Locations for Detectable Warning Surfaces.** Detectable warning surfaces shall be provided at the following locations on pedestrian access routes and at transit stops: (4-44-12 PC3)

1. Curb ramps and blended transitions at pedestrian street crossings;
2. Pedestrian refuge islands;
3. Pedestrian at-grade rail crossings not located within a street or highway;
4. Boarding platforms at transit stops for buses and rail vehicles where the edges of the boarding platform are not protected by screens or guards; and

- Boarding and alighting areas at sidewalk or street level transit stops for rail vehicles where the side of the boarding and alighting areas facing the rail vehicles is not protected by screens or guards.

**Exception:** Detectable warning surfaces shall not be required at pedestrian refuge islands that are cut-through at street level and are less than 6 feet (1830 mm) in length in the direction of pedestrian travel. (4-44-12) (ed.)

## 407 Elevators

**407.1 General.** Elevators shall comply with Section 407 and ASME A17.1/CSA B44 listed in Section 106.2.9. Elevators shall be passenger elevators as classified by ASME A17.1/CSA B44. Elevator operation shall be automatic.

**407.2 Elevator Landing Requirements.** Elevator landings shall comply with Section 407.2.

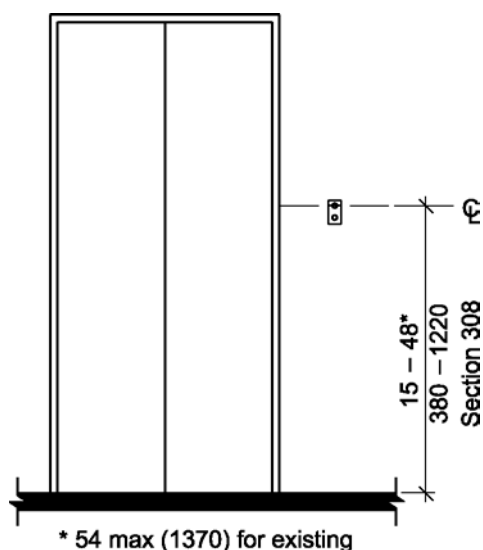
**407.2.1 Call Controls.** Where elevator call buttons or keypads are provided, they shall comply with Sections 407.2.1 and 309.4. Call buttons shall be raised or flush. Objects beneath hall call buttons shall protrude 1 inch (25 mm) maximum.

### EXCEPTIONS:

- Existing elevators shall be permitted to have recessed call buttons.
- The restriction on objects beneath call buttons shall not apply to existing call buttons.

**407.2.1.1 Height.** Call buttons and keypads shall be located within one of the reach ranges specified in Section 308, measured to the centerline of the highest operable part.

**EXCEPTION:** Existing call buttons and existing keypads shall be permitted to be located 54 inches (1370 mm) maximum above the floor, measured to the centerline of the highest operable part.



*Figure 407.2.1.1 – Height of elevator call buttons*

**407.2.1.2 Size.** Call buttons shall be  $\frac{3}{4}$  inch (19 mm) minimum in the smallest dimension.

**EXCEPTION:** Existing elevator call buttons shall not be required to comply with Section

407.2.1.2.

**407.2.1.3 Clear Floor Space.** A clear floor space complying with Section 305 shall be provided at call controls.

**407.2.1.4 Location.** The call button that designates the up direction shall be located above the call button that designates the down direction.

**EXCEPTION:** Destination-oriented elevators shall not be required to comply with Section 407.2.1.4.

**407.2.1.5 Signals.** Call buttons shall have visible signals to indicate when each call is registered and when each call is answered. Call buttons shall provide an audible signal or mechanical motion of the button to indicate when each call is registered.

**EXCEPTIONS:**

1. Destination-oriented elevators shall not be required to comply with Section 407.2.1.5, provided a visible signal and audible tones and verbal announcements complying with Section 407.2.1.7 are provided.
2. Existing elevators shall not be required to comply with Section 407.2.1.5.

**407.2.1.6 Keypads.** Where keypads are provided, keypads shall be in a standard telephone keypad arrangement and shall comply with Section 407.4.7.2.

**407.2.1.7 Destination-oriented Elevator Signals.** Destination-oriented elevators shall be provided with a visible signal and audible tones and verbal announcements to indicate which car is responding to a call. The audible tone and verbal announcement shall be activated by pressing a function button. The function button shall be identified by the International Symbol for Accessibility and a raised indication. The International Symbol for Accessibility, complying with Section 703.6.3.1, shall be  $\frac{5}{16}$  inch (16 mm) in height and be a visual character complying with Section 703.2. The indication shall be three raised dots, spaced  $\frac{1}{4}$  inch (6.4 mm) at base diameter, in the form of an equilateral triangle. The function button shall be located immediately below the keypad arrangement or floor buttons.

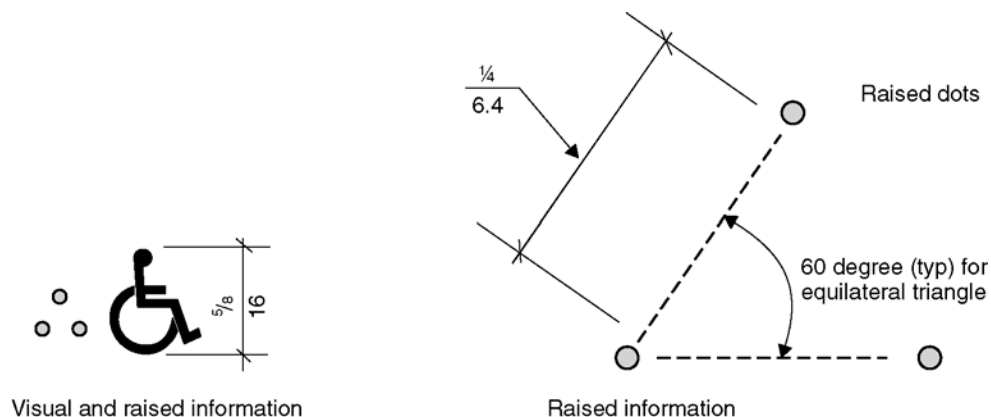


Figure 407.2.1.7 - Destination-oriented elevator indication

**407.2.2 Hall Signals.** Hall signals, including in-car signals, shall comply with Section 407.2.2.

**407.2.2.1 Visible and Audible Signals.** A visible and audible signal shall be provided at each hoistway entrance to indicate which car is answering a call and the car's direction of travel. Where in-car signals are provided they shall be visible from the floor area adjacent to the hall call buttons.

**EXCEPTIONS:**

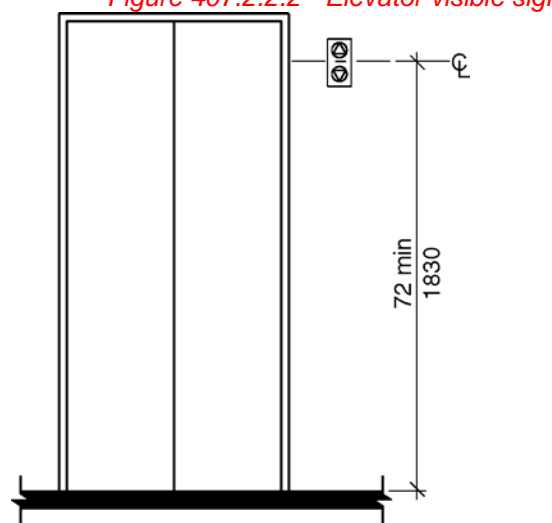
1. Destination-oriented elevators shall not be required to comply with Section 407.2.2.1, provided a visible signal and audible tones and verbal announcements complying with Section 407.2.1.7 are provided.
2. In existing elevators, a signal indicating the direction of car travel shall not be required.

**407.2.2.2 Visible Signals.** Visible signal fixtures shall be centered at 72 inches (1830 mm) minimum above the floor. The visible signal elements shall be 2½ inches (64 mm) minimum between the uppermost and lowest edges of the illuminated shape measured vertically. Signals shall be visible from the floor area adjacent to the hall call button.

**EXCEPTIONS:**

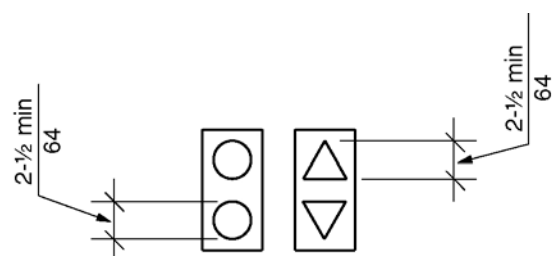
1. Destination-oriented elevators shall be permitted to have signals visible from the floor area adjacent to the hoistway entrance.
2. Existing elevators shall not be required to comply with Section 407.2.2.2.

*Figure 407.2.2.2 - Elevator visible signals.*



**(a) Height of Signals**

*a) height of signals*



**(b) Size of Signals**

*b) size of signals*

**407.2.2.3 Audible Signals.** Audible signals shall sound once for the up direction and twice for the down direction, or shall have verbal annunciators that indicate the direction of elevator car travel. Audible signals shall have a frequency of 1500 Hz maximum. Verbal annunciators shall have a frequency of 300

Hz minimum and 3,000 Hz maximum. The audible signal or verbal annunciator shall be 10 dBA minimum above ambient, but shall not exceed 80 dBA, measured at the hall call button.

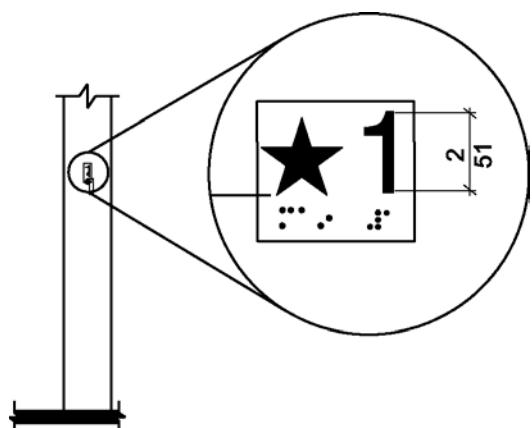
**EXCEPTIONS:**

1. Destination-oriented elevators shall not be required to comply with Section 407.2.2.3, provided the audible tone and verbal announcement is the same as those given at the call button or call button keypad.
2. The requirement for the frequency and range of audible signals shall not apply in existing elevators.

**407.2.2.4 Differentiation.** Each destination-oriented elevator in a bank of elevators shall have audible and visible means for differentiation.

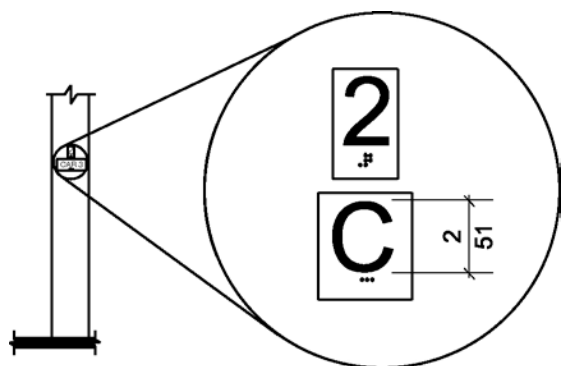
**407.2.3 Hoistway Signs.** Signs at elevator hoistways shall comply with Section 407.2.3.

**407.2.3.1 Floor Designation.** Floor designations shall be provided in raised characters and braille complying with Sections 703.3 and 703.4. Raised characters shall be 2 inches (51 mm) minimum in height. Floor designations shall be located on both jambs of elevator hoistway entrances. A raised star shall be provided on both jambs at the main entry level.



*Figure 407.2.3.1 - Floor designation*

**407.2.3.2 Car Identification.** Destination-oriented elevators shall provide car identification in raised characters and braille complying with Sections 703.3 and 703.4. Raised characters shall be 2 inches (51 mm) minimum in height. Car identifications shall be located on both jambs of the hoistway immediately below the floor designation.



*Figure 407.2.3.2 - Destination-oriented elevator car identification*

**407.2.4 Destination Signs.** Where signs indicate that elevators do not serve all landings, signs in raised characters and braille complying with Sections 703.3 and 703.4 shall be provided above the hall call button or keypad.

**EXCEPTION:** Destination oriented elevator systems shall not be required to comply with Section 407.2.4.

**407.3 Elevator Door Requirements.** Hoistway and elevator car doors shall comply with Section 407.3.

**407.3.1 Type.** Elevator doors shall be horizontal sliding type. Car gates shall be prohibited.

**407.3.2 Operation.** Elevator hoistway and car doors shall open and close automatically.

**EXCEPTION:** Existing manually operated hoistway swing doors shall be permitted, provided the following criteria are met:

- a) The hoistway doors comply with Sections 404.2.2 and 404.2.8;
- b) The car door closing is not initiated until the hoistway door is closed.

**407.3.3 Reopening Device.** Elevator doors shall be provided with a reopening device complying with Section 407.3.3 that shall stop and reopen a car door and hoistway door automatically if the door becomes obstructed by an object or person.

**EXCEPTION:** In existing elevators, manually operated doors shall not be required to comply with Section 407.3.3.

**407.3.3.1 Height.** The reopening device shall be activated by sensing an obstruction passing through the opening at 5 inches (125 mm) nominal and 29 inches (735 mm) nominal above the floor.

**407.3.3.2 Contact.** The reopening device shall not require physical contact to be activated, although contact shall be permitted before the door reverses.

**407.3.3.3 Duration.** The reopening device shall remain effective for 20 seconds minimum.

**407.3.4 Door and Signal Timing.** The minimum acceptable time from notification that a car is answering a call until the doors of that car start to close shall be calculated from the following equation:

$T = D/(1.5 \text{ ft/s})$  or  $T = D/(455 \text{ mm/s}) = 5$  seconds minimum, where T equals the total time in seconds and D equals the distance (in feet or millimeters) from the point in the lobby or corridor 60 inches (1525 mm) directly in front of the farthest call button controlling that car to the centerline of its hoistway door.

**EXCEPTIONS:**

1. For cars with in-car lanterns, T shall be permitted to begin when the signal is visible from the point 60 inches (1525 mm) directly in front of the farthest hall call button and the audible signal is sounded.
2. Destination-oriented elevators shall not be required to comply with Section 407.3.4.

**407.3.5 Door Delay.** Elevator doors shall remain fully open in response to a car call for 3 seconds minimum.

**407.3.6 Width.** Elevator door clear opening width shall comply with Table 407.4.1.



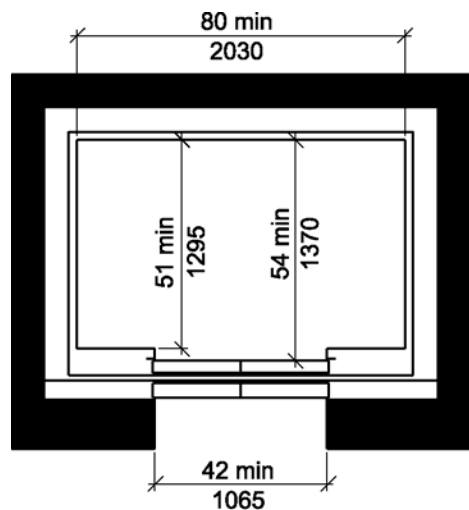
**EXCEPTION:** In existing elevators, a power-operated car door complying with Section 404.2.2 shall be permitted.

**407.4 Elevator Car Requirements.** Elevator cars shall comply with Section 407.4.

**407.4.1 Inside Dimensions.** Inside dimensions of elevator cars shall comply with Table 407.4.1.

**EXCEPTION:** Existing elevator car configurations that provide a clear floor area of 16 square feet (1.5 m<sup>2</sup>) minimum, and provide a clear inside dimension of 36 inches (915 mm) minimum in width and 54 inches (1370 mm) minimum in depth, shall be permitted.

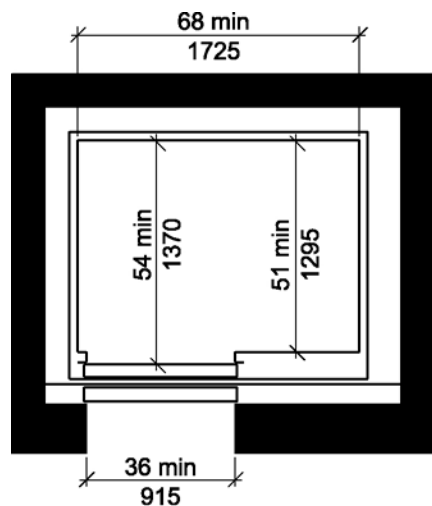
*Figure 407.4.1(a) through (e) - Inside dimension of elevator cars*



(a)

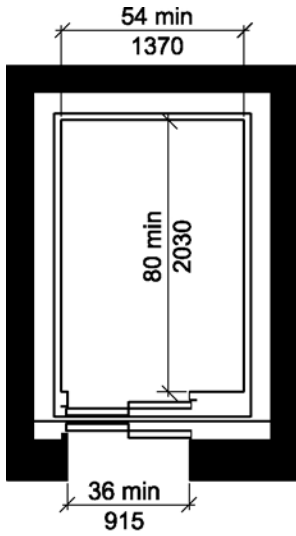
Inside dimension of elevator cars –  
Centered Door Location

*a) center door location*

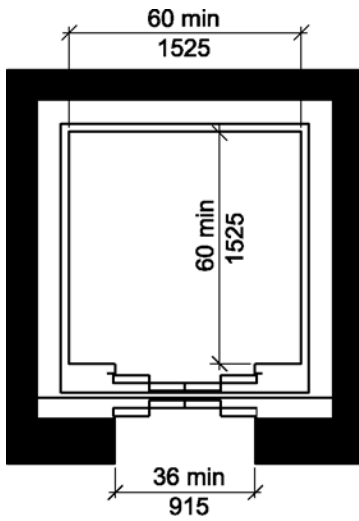


**(b) Side (Off-Centered Door) Location**

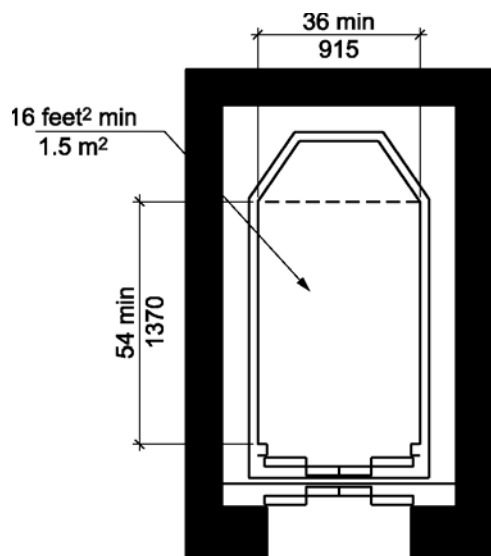
*b) side (off-centered door) location*



**(c) Any Door Location**  
*c) any door location*



**(d) Any Door Location**  
*d) any door location*



**(e) Existing Car Configurations**

*e) existing car configuration*

**Table 407.4.1—Minimum Dimensions of Elevator Cars**

Door Location	Door Clear Opening Width	Inside Car, Side to Side	Inside Car, Back Wall to Front Return	Inside Car, Back Wall to Inside Face of Door
Centered	42 inches (1065 mm) <sub>1</sub>	80 inches (2030 mm)	51 inches (1295 mm)	54 inches (1370 mm)
Side (Off Center)	36 inches (915 mm) <sub>1</sub>	68 inches (1725 mm)	51 inches (1295 mm)	54 inches (1370 mm)
Any	36 inches (915 mm) <sub>1</sub>	54 inches (1370 mm)	80 inches (2030 mm)	80 inches (2030 mm)
Any	36 inches (915 mm) <sub>1</sub>	60 inches (1525 mm) <sub>2</sub>	60 inches (1525 mm) <sub>2</sub>	60 inches (1525 mm) <sub>2</sub>

<sup>1</sup>A tolerance of minus  $\frac{5}{8}$  inch (16 mm) is permitted.

<sup>2</sup>Other car configurations that provide a 36-inch (915mm) door clear opening width and a 60 inch (1525 mm) diameter space with the door closed are permitted. (3-6B-12)

**407.4.2 Floor Surfaces.** Floor surfaces in elevator cars shall comply with Section 302.

**407.4.3 Platform to Hoistway Clearance.** The clearance between the car platform sill and the edge of any hoistway landing shall comply with ASME A17.1/CSA B44 listed in Section 106.2.9.

**407.4.4 Leveling.** Each car shall automatically stop and maintain position at floor landings within a tolerance of  $\frac{1}{2}$  inch (13 mm) under rated loading to zero loading conditions.

**407.4.5 Illumination.** The level of illumination at the car controls, platform, car threshold and car landing sill shall comply with ASME A17.1/CSA B44 listed in Section 106.2.9

**407.4.6 Elevator Car Controls.** Where provided, elevator car controls shall comply with Sections 407.4.6 and 309.

**EXCEPTION:** In existing elevators, where a new car operating panel complying with Section

407.4.6 is provided, existing car operating panels shall not be required to comply with Section 407.4.6.

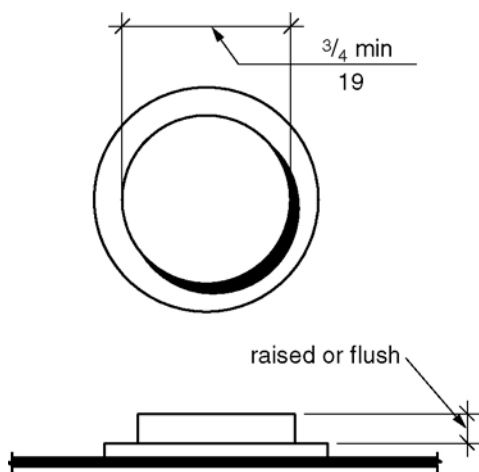
**407.4.6.1 Location.** Controls shall be located within one of the reach ranges specified in Section 308.

**EXCEPTIONS:**

1. Where the elevator panel complies with Section 407.4.8.
2. In existing elevators, where a parallel approach is provided to the controls, car control buttons with floor designations shall be permitted to be located 54 inches (1370 mm) maximum above the floor. *Where the panel is changed, it shall comply with Section 308. (4-49-12)*

**407.4.6.2 Buttons.** Car control buttons with floor designations shall be raised or flush, and shall comply with Section 407.4.6.2.

**EXCEPTION:** In existing elevators, buttons shall be permitted to be recessed.



**Figure 407.4.6.2 - Elevator car control buttons**

**407.4.6.2.1 Size.** Buttons shall be  $\frac{3}{4}$  inch (19 mm) minimum in their smallest dimension.

**407.4.6.2.2 Arrangement.** Buttons shall be arranged with numbers in ascending order. *When two or more columns of buttons are provided they shall read from left to right. (4-50-12)*

**407.4.6.3 Keypads.** Where provided, car control keypads shall be in a standard telephone keypad arrangement and shall comply with Section 407.4.7.2.

**407.4.6.4 Emergency Controls.** Emergency controls shall comply with Section 407.4.6.4.

**407.4.6.4.1 Height.** Emergency control buttons shall have their centerlines 35 inches (890 mm) minimum above the floor.

**407.4.6.4.2 Location.** Emergency controls, including the emergency alarm, shall be grouped at the bottom of the panel.

**407.4.7 Designations and Indicators of Car Controls.** Designations and indicators of car controls shall comply with Section 407.4.7.

**EXCEPTIONS:**

1. In existing elevators, where a new car operating panel complying with Section 407.4.7 is provided, existing car operating panels shall not be required to comply with Section 407.4.7.
2. Where existing building floor designations differ from the arrangement required by Section 407.4.6.2.2, or are alphanumeric, a new operating panel shall be permitted to use such existing building floor designations.

**407.4.7.1 Buttons.** Car control buttons shall comply with Section 407.4.7.1.

**407.4.7.1.1 Type.** Control buttons shall be identified by raised characters and braille complying with Sections 703.3 and 703.4.

**407.4.7.1.2 Designation.** Floors shall be designated . . . -4, -3, -2, -1, 0, 1, 2, 3, 4, etcetera, with floors below the main entry floor designated with minus numbers. Numbers shall be permitted to be omitted, provided the remaining numbers are in sequence. Where a telephone keypad arrangement is used, the number key (“#”) shall be utilized to enter the minus symbol (“-”). Ancillary letters shall be permitted to be used in conjunction with the numbers provided the letters are located to the right of the numbers and not more than two letters are used for each floor designation. (4-50-12)

**407.4.7.1.3 Location.** Raised character and braille designations shall be placed immediately to the left of the control button to which the designations apply. Where a negative number is used to indicate a negative floor, the braille designation shall be a cell with the dots 3 and 6 followed by the ordinal number.

**EXCEPTION:** Where space on an existing car operating panel precludes raised characters and braille to the left of the control button, markings shall be placed as near to the control button as possible.

**407.4.7.1.4 Symbols.** The control button for the emergency stop, alarm, door open, door close, main entry floor, and phone, shall be identified with raised symbols and braille as shown in Table 407.4.7.1.4.

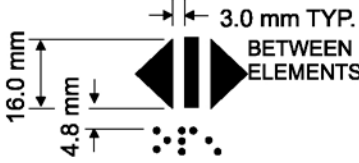


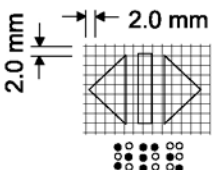



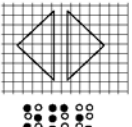

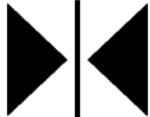

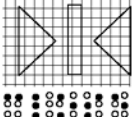



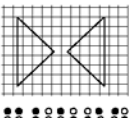



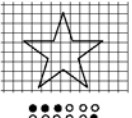



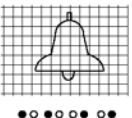



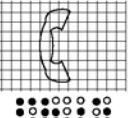



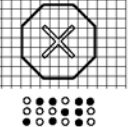
Control Button Type	Raised Symbol	Braille Message	Proportions (Open circles indicate unused dots within each braille cell)
 <p>DOOR OPEN</p>		 <p>op"en"</p>	
 <p>REAR/SIDE DOOR OPEN</p>		 <p>op"en"</p>	
 <p>DOOR CLOSE</p>		 <p>close</p>	
 <p>REAR/SIDE DOOR CLOSE</p>		 <p>close</p>	
 <p>MAIN</p>		 <p>ma"in"</p>	
 <p>ALARM</p>		 <p>al"ar"m</p>	
 <p>PHONE</p>		 <p>ph"one"</p>	
 <p>EMERGENCY STOP (WHEN PROVIDED) X on face of octagon is not required to be tactile</p>		 <p>"st"op</p>	

Table 407.4.7.1.4 - Control button identification

**407.4.7.1.5 Visible Indicators.** Buttons with floor designations shall be provided with visible indicators to show that a call has been registered. The visible indication shall extinguish when the car arrives at the designated floor.

**407.4.7.2 Keypads.** Keypad keys shall be identified by visual characters complying with Section 703.2 centered on the corresponding keypad button. The number five key shall have a single raised dot. The dot shall have a base diameter of 0.118 inch (3 mm) minimum and 0.120 inch (3.05 mm) maximum, and a height of 0.025 inch (0.6 mm) minimum and 0.037 inch (0.9 mm) maximum.

**407.4.8 Elevator Car Call Sequential Step Scanning.** Elevator car call sequential step scanning shall be provided where car control buttons are provided more than 48 inches (1220 mm) above the floor. Floor selection shall be accomplished by applying momentary or constant pressure to the up or down scan button. The up scan button shall sequentially select floors above the current floor. The down scan button shall sequentially select floors below the current floor. When pressure is removed from the up or down scan button for more than 2 seconds, the last floor selected shall be registered as a car call. The up and down scan button shall be located adjacent to or immediately above the emergency control buttons.

**407.4.9 Car Position Indicators.** Audible and visible car position indicators shall be provided in elevator cars.

**407.4.9.1 Visible Indicators.** Visible indicators shall comply with Section 407.4.9.1.

**407.4.9.1.1 Size.** Characters shall be 5/8 inch (16 mm) minimum in height. (4-53-12)

**407.4.9.1.2 Location.** Indicators shall be located above the car control panel or above the door.

**407.4.9.1.3 Floor Arrival.** As the car passes a floor and when a car stops at a floor served by the elevator, the corresponding character shall illuminate.

**EXCEPTION:** Destination-oriented elevators shall not be required to comply with Section 407.4.9.1.3, provided the visible indicators extinguish when the call has been answered.

**407.4.9.1.4 Destination Indicator.** In destination-oriented elevators, a display shall be provided in the car with visible indicators to show car destinations.

**407.4.9.2 Audible Indicators.** Audible indicators shall comply with Section 407.4.9.2.

**407.4.9.2.1 Signal Type.** The signal shall be an automatic verbal annunciator that announces the floor at which the car is about to stop. The verbal announcement indicating the floor shall be completed prior to the initiation of the door opening.

**EXCEPTION:** For elevators other than destination-oriented elevators that have a rated speed of 200 feet per minute (1 m/s) maximum, a non-verbal audible signal with a frequency of 1500 Hz maximum that sounds as the car passes or is about to stop at a floor served by the elevator shall be permitted.

**407.4.9.2.2 Signal Level.** The verbal annunciator shall be 10 dBA minimum above ambient, but shall not exceed 80 dBA, measured at the annunciator.

**407.4.9.2.3 Frequency.** The verbal annunciator shall have a frequency of 300 Hz minimum and 3,000 Hz maximum.

**407.4.10 Emergency Communications.** Emergency two-way communication systems between the elevator car and a point outside the hoistway shall comply with Section 407.4.10 and ASME A17.1/CSA B44 listed in Section 106.2.9. (4-54-12 PC1 through PC3)

**407.4.10.1 Height.** The highest operable part of a two-way communication system shall comply with Section 308.

**407.4.10.2 Identification.** Raised characters and braille complying with Sections 703.3 and 703.4 and raised symbols complying with Section 407.4.7.1.4 shall be provided adjacent to the device.

**407.4.10.3 Instructions.** Where instructions for use are provided, essential information shall be presented in visual form, raised characters and braille complying with Sections 703.2, 703.3 and 703.4. (4-55-12)

## **408 Limited-Use/Limited-Application Elevators**

**408.1 General.** Limited-use/limited-application elevators shall comply with Section 408 and ASME A17.1/CSA B44 listed in Section 106.2.9. Elevator operation shall be automatic.

**408.2 Elevator Landing Requirements.** Landings serving limited-use/limited application elevators shall comply with Section 408.2.

**408.2.1 Call Controls.** Elevator call buttons and keypads shall comply with Section 407.2.1.

**408.2.2 Hall Signals.** Hall signals shall comply with Section 407.2.2.

**408.2.3 Hoistway Signs.** Signs at elevator hoistways shall comply with Section 407.2.3.

**408.3 Elevator Door Requirements.** Elevator hoistway doors shall comply with Section 408.3.

**408.3.1 Sliding Doors.** Sliding hoistway and car doors shall comply with Sections 407.3.1 through 407.3.3, and 408.3.3.

**408.3.2 Swinging Doors.** Swinging hoistway doors shall open and close automatically and shall comply with Sections 408.3.2, 404, and 407.3.2.

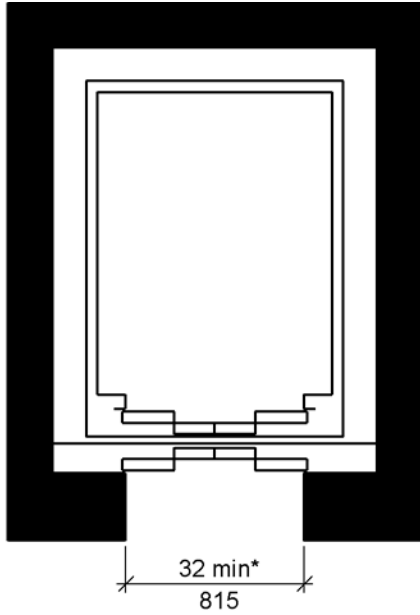
**408.3.2.1 Power Operation.** Swinging doors shall be power-operated and shall comply with BHMA A156.19 listed in Section 106.2.7

**408.3.2.2 Duration.** Power-operated swinging doors shall remain open for 20 seconds minimum when activated.

**408.3.3 Door Location and Width.** Car doors shall comply with Section 408.3.3.

*Figure 408.3.3 (a) thru (d) - Door location for limited use/limited application (LULA) elevators*

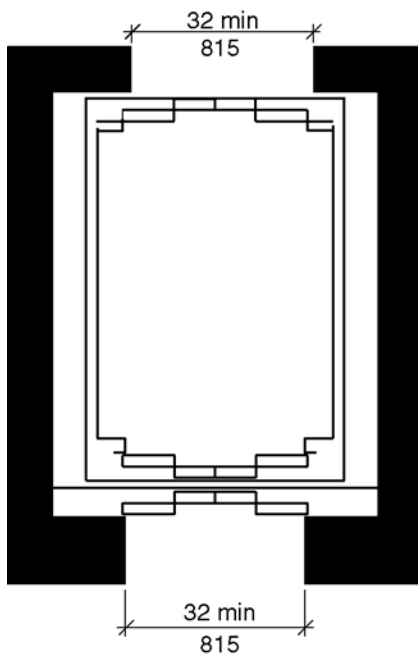




**(a) Car with Single Door**

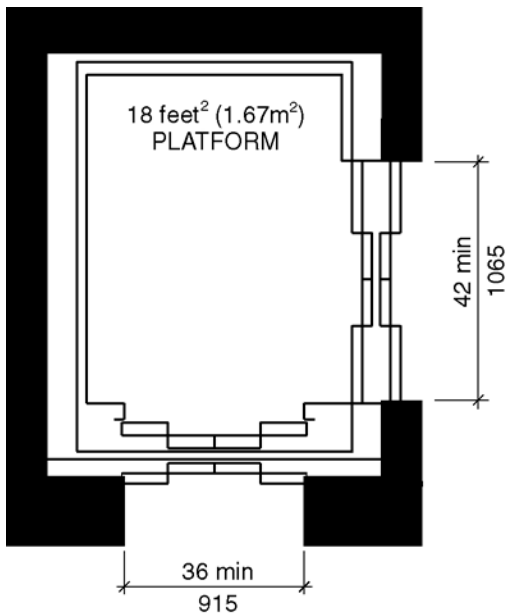
\*Door opening size from Section 408.3.3

*a) car with single door*

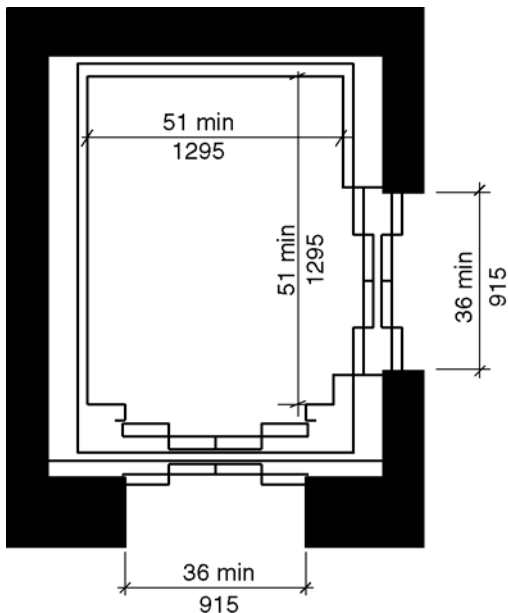


**(b) Doors on Opposite Sides**

*b) car with doors on opposite sides*



(c) Car with Doors on Adjacent Sides  
*c) car with doors on adjacent sides*



(d) Car with Doors on Adjacent Sides  
*d) car with doors on adjacent sides - exception*

**408.3.3.1 Cars with Single Door or Doors on Opposite Ends.** Car doors shall be positioned at the narrow end of cars with a single door and on cars with doors on opposite ends. Doors shall provide a clear opening width of 32 inches (815 mm) minimum.

**408.3.3.2 Cars with Doors on Adjacent Sides.** Car doors shall be permitted to be located on adjacent sides of cars that provide an 18 square foot (1.67 m<sup>2</sup>) platform. Doors located on the narrow end of cars shall provide a clear opening width of 36 inches (815 mm) minimum. Doors located on the long side shall provide a clear opening width of 42 inches (1065 mm) minimum and be located as far as practicable from the door on the narrow end.

**EXCEPTION:** Car doors that provide a clear opening width of 36 inches (915 mm) minimum shall be permitted to be located on adjacent sides of cars that provide a clear floor area of 51 inches (1295 mm) in width and 51 inches (1295 mm) in depth.

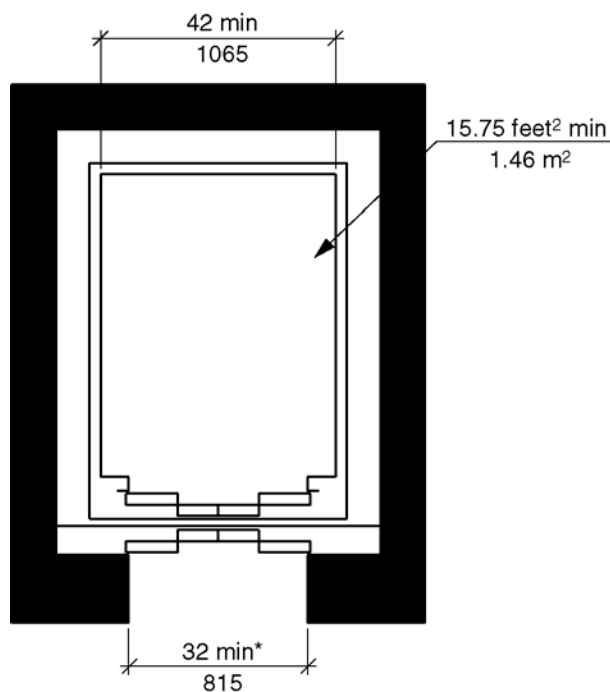
**408.4 Elevator Car Requirements.** Elevator cars shall comply with Section 408.4.

**408.4.1 Inside Dimensions.** Elevator cars shall provide a clear floor width of 42 inches (1065 mm) minimum. The clear floor area shall not be less than 15.75 square feet (1.46 m<sup>2</sup>). The elevator car shall provide a clear floor space complying with Section 305.3.

**EXCEPTIONS:**

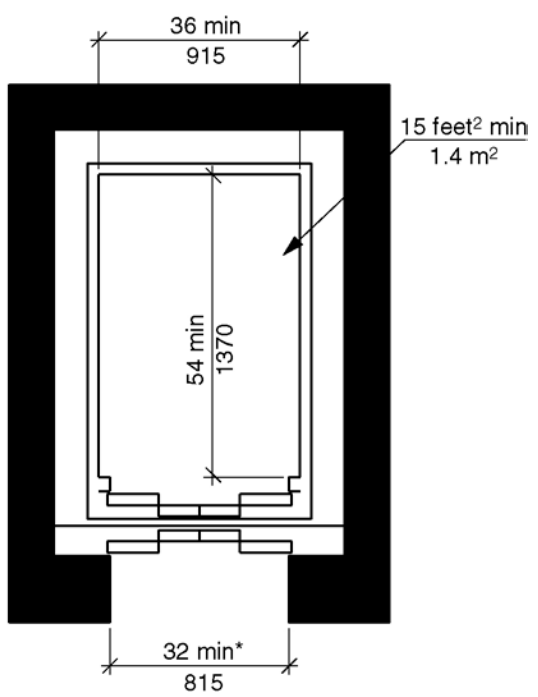
1. For installations in existing buildings, elevator cars that provide a clear floor area of 15 square feet (1.4 m<sup>2</sup>) minimum, and provide a clear inside dimension of 36 inches (915 mm) minimum in width and 54 inches (1370 mm) minimum in depth, shall be permitted. This exception shall not apply to cars with doors on adjacent sides.
2. For installations in existing buildings, elevator cars that provide a clear width of 51 inches (1295 mm) minimum, a clear depth of 51 inches (1295 mm) minimum and car doors providing a clear opening 36 inches (915 mm) wide minimum shall be permitted. (4-56-12) (3-6-12 PC2) (ed.)

*Figure 408.4.1 (a) thru (c)– Inside dimensions of limited use/limited application (LULA) elevator cars*



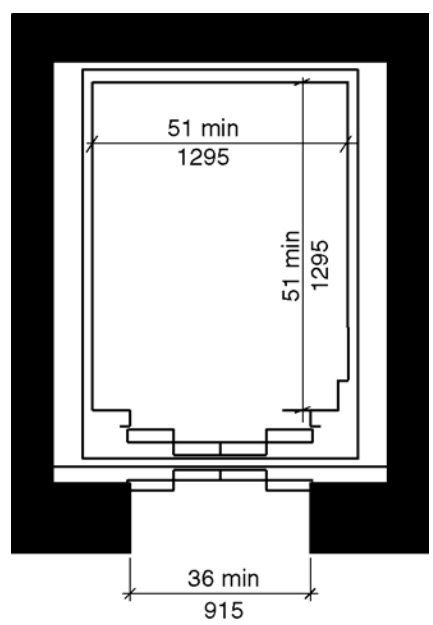
**(a) New Construction**

*a) new construction*



**(b) Existing Building Exception**

\*Door opening size from Section 408.3.3  
*b) existing buildings, exception 1*



**(c) Existing Building - Exception 2**

*c) existing buildings, exception 2*

**408.4.2 Floor Surfaces.** Floor surfaces in elevator cars shall comply with Section 302.

**408.4.3 Platform to Hoistway Clearance.** The clearance between the car platform sill and the edge of any hoistway landing shall comply with ASME A17.1/CSA B44 listed in Section 106.2.9.

**408.4.4 Leveling.** Elevator car leveling shall comply with Section 407.4.4.

**408.4.5 Illumination.** Elevator car illumination shall comply with Section 407.4.5.

**408.4.6 Elevator Car Controls.** Elevator car controls shall comply with Section 407.4.6. Control panels shall be centered on a side wall.

**408.4.7 Designations and Indicators of Car Controls.** Designations and indicators of car controls shall comply with Section 407.4.7.

**408.4.8 Emergency Communications.** Car emergency signaling devices complying with Section 407.4.10 shall be provided.

#### **409 Private Residence Elevators**

**409.1 General.** Private residence elevators shall comply with Section 409 and ASME A17.1/CSA B44 listed in Section 106.2.9. Elevator operation shall be automatic.

**EXCEPTION:** Elevators complying with Section 407 or 408 shall not be required to comply with Section 409.

**409.2 Call Controls.** Call buttons at elevator landings shall comply with Section 309. Call buttons shall be  $\frac{3}{4}$  inch (19 mm) minimum in their smallest dimension.

**409.3 Doors and Gates.** Elevator car and hoistway doors and gates shall comply with Sections 409.3 and 404.

**EXCEPTION:** The maneuvering clearances required by Section 404.2.3 shall not apply for approaches to the push side of swinging doors.

**409.3.1 Power Operation.** Elevator car doors and gates shall be power operated and shall comply with BHMA A156.19 listed in Section 106.2.7. Elevator cars with a single opening shall have low energy power operated hoistway doors and gates.

**EXCEPTION:** Hoistway doors or gates shall be permitted to be of the self-closing, manual type, where that door or gate provides access to a narrow end of the car that serves only one landing.

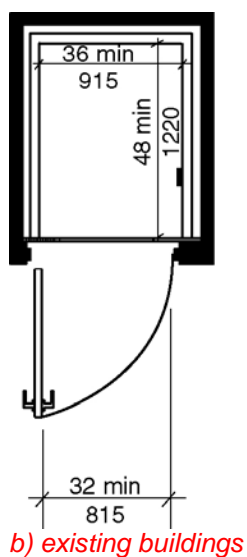
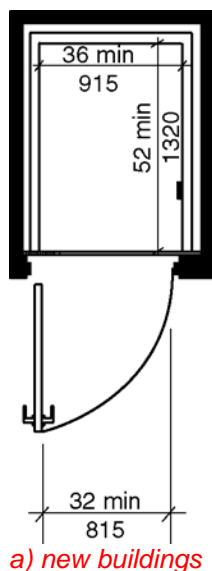
**409.3.2 Duration.** Power operated doors and gates shall remain open for 20 seconds minimum when activated.

**409.3.3 Door or Gate Location and Width.** Car gates or doors positioned at a narrow end of the clear floor area required by Section 409.4.1 shall provide a clear opening width of 32 inches (815 mm) minimum. Car gates or doors positioned on adjacent sides shall provide a clear opening width of 42 inches (1065 mm) minimum.

**409.4 Elevator Car Requirements.** Elevator cars shall comply with Section 409.4.

##### **409.4.1 Inside Dimensions.**

*Figure 409.4.1 (a) and (b) – Private residence elevators – car size*



**409.4.1.1 New buildings.** In new buildings, elevator cars shall provide a clear floor area 36 inches (915 mm) minimum in width and 52 inches (1322 mm) minimum in depth. (3-13B-12)

**409.4.1.2 Existing buildings ~~and within new Type B units.~~** In existing buildings ~~and within new Type B units~~, elevator cars shall provide a clear floor area 36 inches (915 mm) minimum in width and 48 inches (1220 mm) minimum in depth. (3-6-12 PC2) (ed.)

**409.4.2 Floor Surfaces.** Floor surfaces in elevator cars shall comply with Section 302.

**409.4.3 Platform to Hoistway Clearance.** The clearance between the car platform sill and the edge of any hoistway landing shall be  $1\frac{1}{4}$  inches (32 mm) maximum.

**409.4.4 Leveling.** Each car shall automatically stop at a floor landing within a tolerance of  $\frac{1}{2}$  inch (13 mm) under rated loading to zero loading conditions.

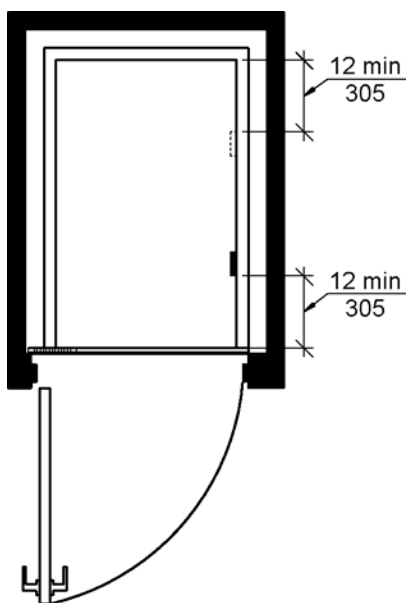
**409.4.5 Illumination.** The level of illumination at the car controls, platform, and car threshold and landing sill shall be 5 foot-candles (54 lux) minimum.

**409.4.6 Elevator Car Controls.** Elevator car controls shall comply with Sections 409.4.6 and 309.4.

**409.4.6.1 Buttons.** Control buttons shall be  $\frac{3}{4}$  inch (19 mm) minimum in their smallest dimension. Control buttons shall be raised or flush.

**409.4.6.2 Height.** Buttons with floor designations shall comply with Section 309.3.

**409.4.6.3 Location.** Controls shall be on a sidewall, 12 inches (305 mm) minimum from any adjacent wall.



*Figure 409.4.6.3 - Location of controls in private residence elevators*

**409.4.7 Emergency Communications.** Emergency communications systems shall comply with Section 409.4.7.

**409.4.7.1 Type.** A telephone and emergency signal device shall be provided in the car.

**409.4.7.2 Operable Parts.** The telephone and emergency signaling device shall comply with Section 309.3 and 309.4.

**409.4.7.3 Compartment.** If the device is in a closed compartment, the compartment door hardware shall comply with Section 309.

**409.4.7.4 Cord.** The telephone cord shall be 29 inches (735 mm) minimum in length.

## 410 Platform Lifts

**410.1 General.** Platform lifts shall comply with Section 410 and ASME A18.1 listed in Section 106.2.10. Platform lifts shall not be attendant operated and shall provide unassisted entry and exit from the lift.

**410.2 Lift Entry.** Lifts with doors or gates shall comply with Section 410.2.1. Lifts with ramps shall comply with Section 410.2.2.

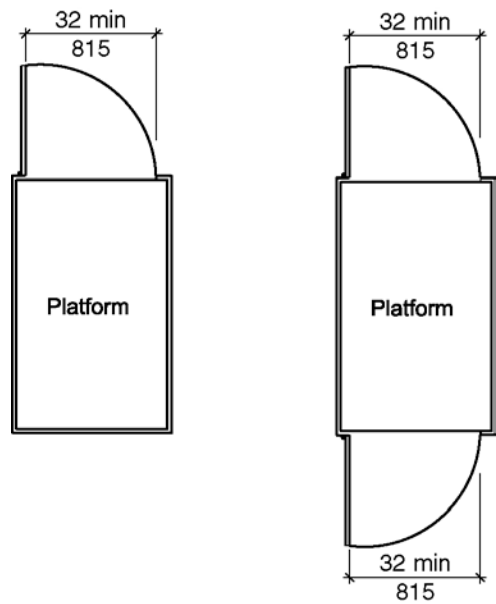
**410.2.1 Doors and Gates.** Doors and gates shall be low energy power operated doors or gates complying with Section 404.3. Doors shall remain open for 20 seconds minimum. On lifts with one door or with doors on opposite ends, the end door clear opening width shall be 32 inches (815 mm) minimum. On

lifts with one door on a narrow end and one door on a long side, the end door clear opening width shall be 36 inches (915 mm) minimum. Side door clear opening width shall be 42 inches (1065 mm) minimum. Where a door is provided on a long side and on a narrow end of a lift, the side door shall be located with either the strike side or the hinge side in the corner furthest from the door on the narrow end.

**EXCEPTIONS:**

- 1. Doors or gates shall be permitted to be of the self-closing, manual type, where that door or gate provides access to a narrow end of the platform that serves only one landing. This exception shall not apply to doors or gates with ramps.
- 2. Lifts serving two landings maximum and having doors or gates on adjacent sides shall be permitted to have self closing manual doors or gates provided that the side door or gate is located with the strike side furthest from the end door. This exception shall not apply to door or gates with ramps.

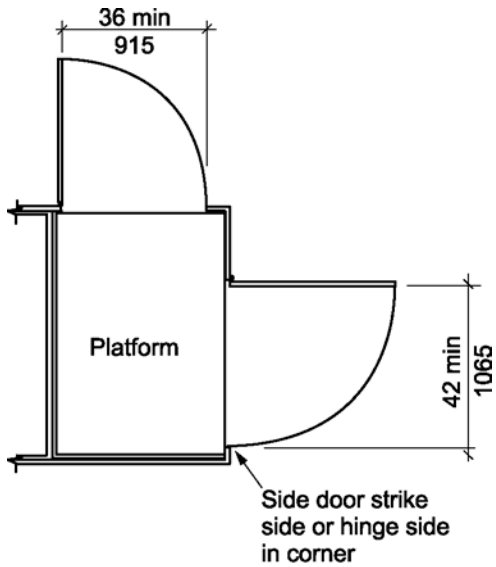
*Figure 410.2.1(a) and (b) – platform lift doors and gates – size*



**(a) Platform lift with door at one end or opposite ends**

*a) platform lift with door at one end or at opposite ends*





(b) Platform with doors on adjacent sides  
*b) platform with doors on adjacent sides*

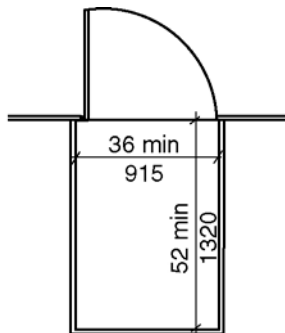
**410.2.2 Ramps.** Ramp widths shall not be less than the platform opening they serve.

**410.3 Floor Surfaces.** Floor surfaces of platform lifts shall comply with Section 302.

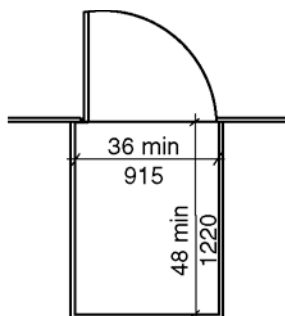
**410.4 Platform to Runway Clearance.** The clearance between the platform sill and the edge of any runway landing shall be 1<sup>1</sup>/<sub>4</sub> inch (32 mm) maximum.

**410.5 Clear Floor Space.** Clear floor space of platform lifts shall comply with Section 410.5.

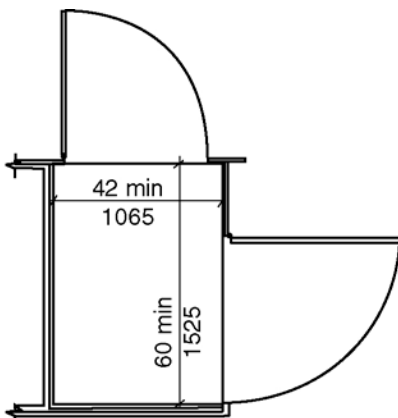
*Figure 410.5(a) thru (c) – platform lift size*



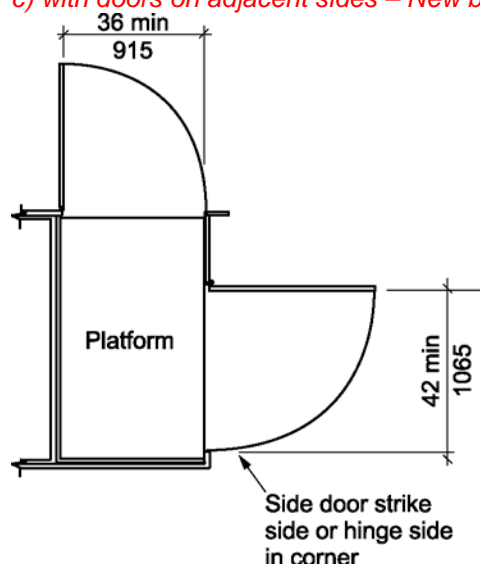
*a) with single door or doors on opposite end – New buildings*



*b) with single door or doors on opposite end – Existing buildings*



*c) with doors on adjacent sides – New buildings*



**(d) Platform with doors on adjacent sides**

*d) with doors on adjacent sides – Existing buildings*

#### **410.5.1 Lifts with Single Doors or Doors on Opposite Ends.**

**410.5.1.1 New buildings.** In new buildings, platform lifts with a single door or doors on opposite ends shall provide a clear floor width of 36 inches (915 mm) minimum and a clear floor depth of 52 inches (1322 mm). (3-13C-12)

**Exception:** Incline platform lifts with passenger restraining arms, shall be permitted to provide a clear floor width of 36 inches (915 mm) minimum and a clear floor depth of 48 inches (1220) mm. (3-13C-12)

**410.5.1.2 Existing buildings and within new Type B units.** In existing buildings and within new Type B units, platform lifts with a single door or doors on opposite ends shall provide a clear floor width of 36 inches (915 mm) minimum and a clear floor depth of 48 inches (1220 mm). (3-6-12 PC2) (ed.)

**410.5.2 Lifts with Doors on Adjacent Sides.** Platform lifts with doors on adjacent sides shall provide a clear floor width of 42 inches (1065 mm) minimum and a clear floor depth of 60 inches (1525 mm) minimum.

**Exception:** In existing buildings, platform lifts with doors on adjacent sides shall be permitted to

provide a clear floor width of 36 inches (915 mm) and a clear floor depth of 60 inches (1525 mm).

**410.6 Operable Parts.** Controls for platform lifts shall comply with Section 309.



## Chapter 5. General Site and Building Elements

### 501 General

**501.1 Scope.** General site and building elements required to be accessible by the scoping provisions adopted by the administrative authority shall comply with the applicable provisions of Chapter 5.

### 502 Parking Spaces

**502.1 General.** Accessible car and van parking spaces in parking lots shall comply with Sections 502.2 through 502.8. Accessible car and van parking spaces provided as part of on-street parking shall comply with Sections 502.9 through 502.10. (5-1-12) (ed.)

**502.2 Vehicle Space Size.** Car parking spaces shall be 96 inches (2440 mm) minimum in width. Van parking spaces shall be 132 inches (3350 mm) minimum in width.

**EXCEPTION:** Van parking spaces shall be permitted to be 96 inches (2440 mm) minimum in width where the adjacent access aisle is 96 inches (2440 mm) minimum in width.

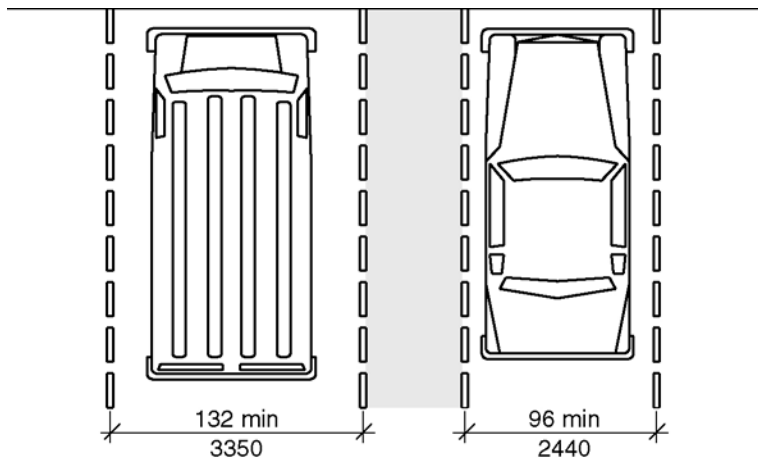


Figure 502.2(a) – Vehicle parking space size

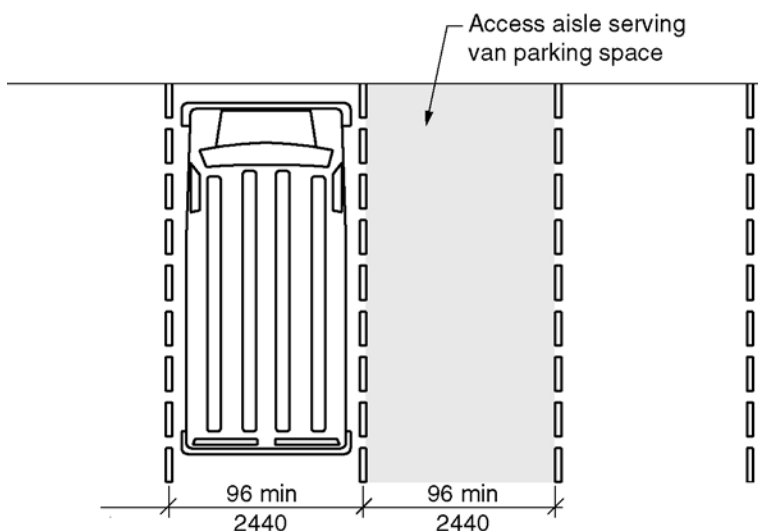
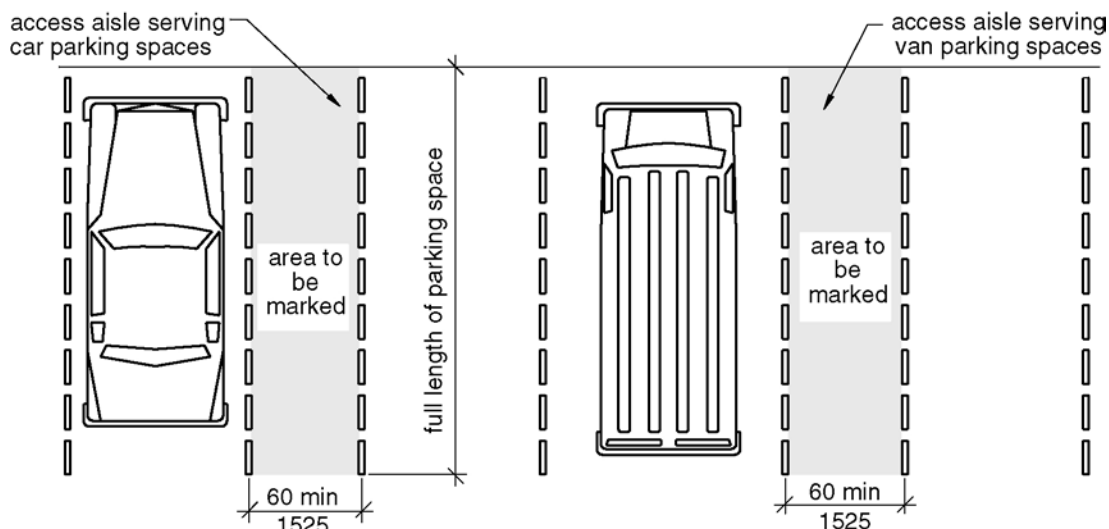


Figure 502.2(b) – Van parking space size exception

**502.3 Vehicle Space Marking.** Car and van parking spaces shall be marked to define the width. Where parking spaces are marked with lines, the width measurements of parking spaces and adjacent access aisles shall be made from the centerline of the markings.

**EXCEPTION:** Where parking spaces or access aisles are not adjacent to another parking space or access aisle, measurements shall be permitted to include the full width of the line defining the parking space or access aisle.

**502.4 Access Aisle.** Car and van parking spaces shall have an adjacent access aisle complying with Section 502.4.



*Figure 502.4 – Parking space access aisles*

**502.4.1 Location.** Access aisles shall adjoin an accessible route. Two parking spaces shall be permitted to share a common access aisle. Access aisles shall not overlap with the vehicular way. Parking spaces shall be permitted to have access aisles placed on either side of the car or van parking space. Van parking spaces that are angled shall have access aisles located on the passenger side of the parking space.

**502.4.2 Width.** Access aisles serving car and van parking spaces shall be 60 inches (1525 mm) minimum in width. (3-6C-12 PC3 through PC10) (3-6-12 PC2.1)

**502.4.3 Length.** Access aisles shall extend the full length of the parking spaces they serve.

**502.4.4 Marking.** Access aisles shall be marked so as to discourage parking in them. Where access aisles are marked with lines, the width measurements of access aisles and adjacent parking spaces shall be made from the centerline of the markings.

**EXCEPTION:** Where access aisles or parking spaces are not adjacent to another access aisle or parking space, measurements shall be permitted to include the full width of the line defining the access aisle or parking space.

**502.5 Floor Surfaces.** Parking spaces and access aisles shall comply with Section 302 and have surface slopes not steeper than 1:48. Access aisles shall be at the same level as the parking spaces they serve.

**502.6 Vertical Clearance.** A vertical clearance of 98 inches (2490 mm) minimum shall be provided at the following locations:

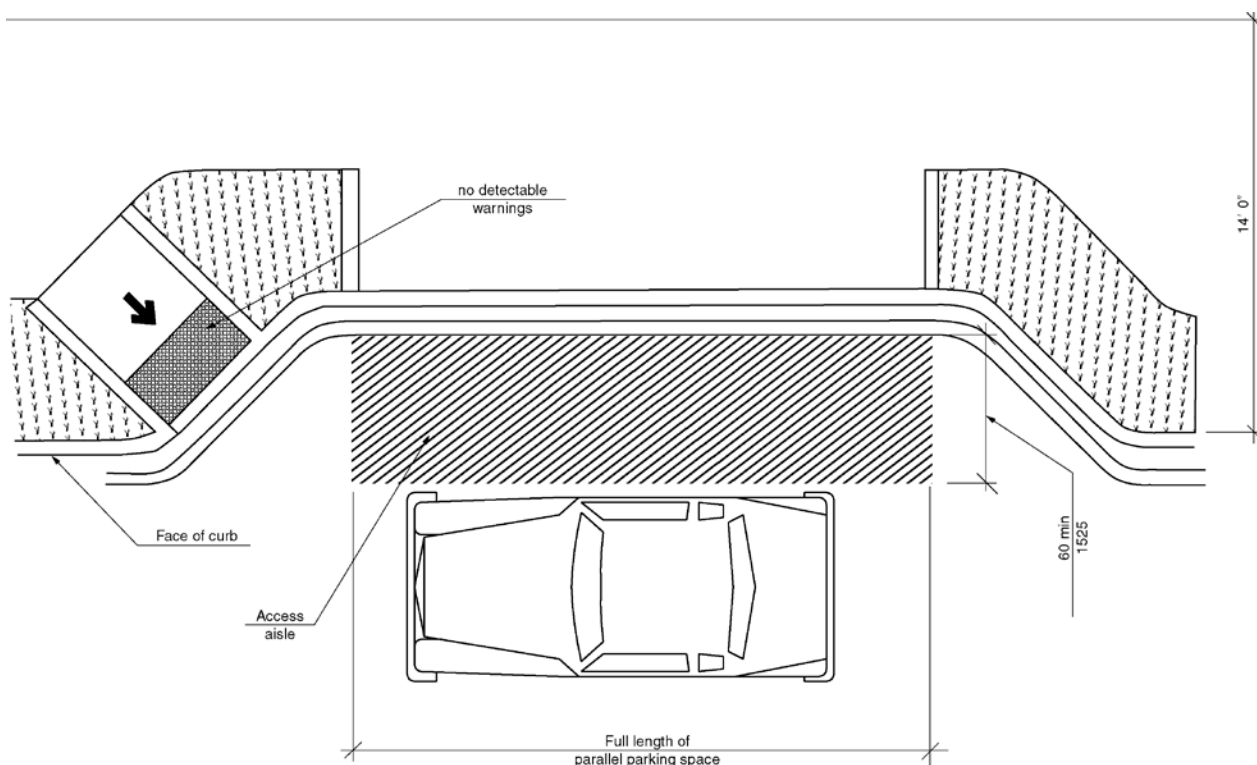
1. Parking spaces for vans.
2. The access aisles serving parking spaces for vans.
3. The vehicular routes serving parking spaces for vans.

**502.7 Identification.** Where **accessible** parking spaces are required to be identified by signs, the signs shall include the International Symbol of Accessibility complying with Section 703.6.3.1. Signs identifying van parking spaces shall contain the designation “van accessible.” Such signs shall be 60 inches (1525 mm) minimum above the floor of the parking space, measured to the bottom of the sign. (ed.)

**502.8 Relationship to Accessible Routes.** Parking spaces and access aisles shall be designed so that cars and vans, when parked, **do not** obstruct the required clear width of adjacent accessible routes. (ed.)

**502.9 Parallel Parking Spaces.** On-street parallel parking spaces shall comply with Section 502.9.1. On-street perpendicular or angled parking shall comply with Section 502.9.2. (5-1-12)

**502.9.1 Wide Sidewalks.** Where the width of the adjacent sidewalk or available right-of-way exceeds 14 feet (4267 mm), an access aisle 60 inches (1525 mm) wide minimum shall be provided at street level the full length of the parking space and shall connect to a pedestrian access route. The access aisle shall comply with Section 502.4 and shall not encroach on the vehicular travel lane. (5-1-12)



**Figure 502.9.1 – Wide sidewalk**

**502.9.1.1 Alterations.** In alterations where the street or sidewalk adjacent to the parking spaces is not altered, an access aisle shall not be required provided the parking spaces are located at the end of the block face. (5-1-12)

**502.9.1.2 Narrow Sidewalks.** An access aisle is not required where the width of the adjacent sidewalk or the available right-of-way is less than or equal to 14 feet (4267 mm). Where an access aisle is not provided, the parking spaces shall be located at the end of the block face. (5-1-12)

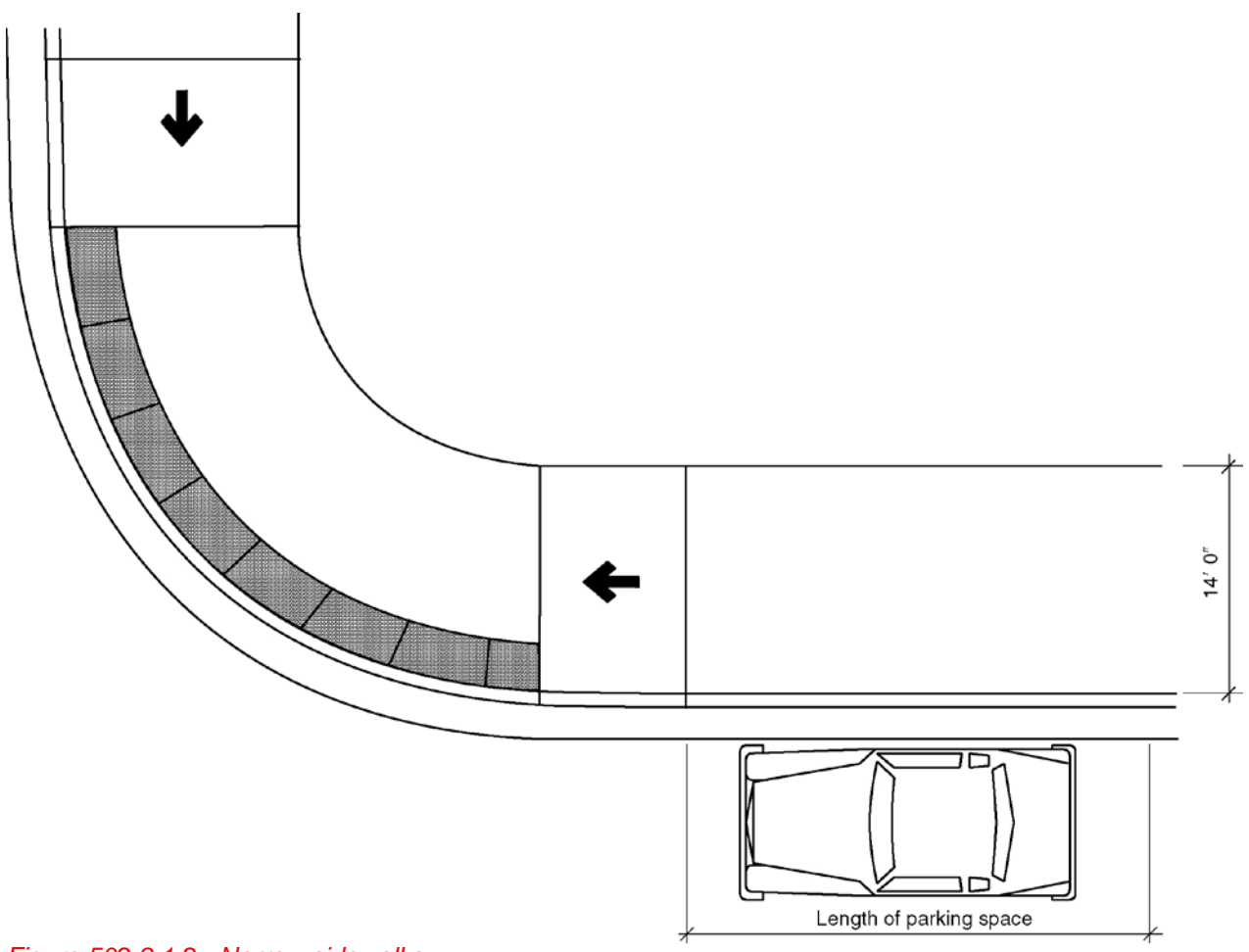
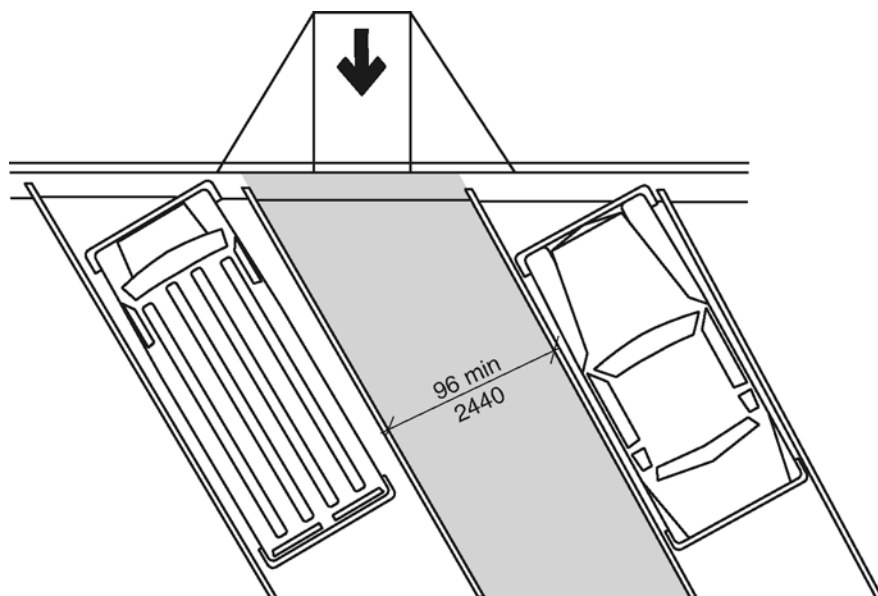


Figure 502.9.1.2 - Narrow sidewalks

**502.9.2 Perpendicular or Angled Parking Spaces.** Where perpendicular or angled parking is provided, an access aisle 96 inches (2440 mm) wide minimum shall be provided at street level the full length of the parking space and shall connect to a pedestrian access route. The access aisle shall comply with Section 502.4 and shall be marked so as to discourage parking in the access aisle. Two parking spaces are permitted to share a common access aisle. (5-1-12)





**Figure 502.9.2 - Perpendicular or Angled Parking Spaces**

**502.10 Parking Meters and Parking Pay Stations.** Parking meters and parking pay stations that serve **accessible** parking spaces shall comply with Section 309. (5-1-12) (ed.)

**502.10.1 Location.** At **accessible** parallel parking spaces, parking meters shall be located at the head or foot of the parking space. (5-1-12) (ed.)

**502.10.2 Displays and Information.** Displays and information shall be visible from a point located 40 inches (1016 mm) maximum above the center of the clear space in front of the parking meter or parking pay station. (5-1-12)

**502.11 Electrical vehicle charging stations.** Where an electrical vehicle charging station is provided at an **accessible** parking space, it shall comply with Section 502.11. (5-1-13) (ed.)

**502.11.1 Operable parts.** Operable parts on the charging station intended for operation by the user, including card readers, shall comply with Section 309. (5-1-13)

**502.11.2 Accessible route.** An accessible route shall be provided from the access aisle adjacent to the **accessible** parking space to the clear floor space complying with Section 502.11.1 adjacent to the vehicle charging station. When the vehicle is being charged, the accessible route shall not be obstructed by the cable between the car and charging station. (5-1-13) (ed.)

**502.11.3 Obstructions.** Protection bollards, curbs or wheel stops shall be located so that they do not obstruct the clear floor space required by Section 502.11.1 or the accessible route required by Section 502.11.2. (5-1-13)

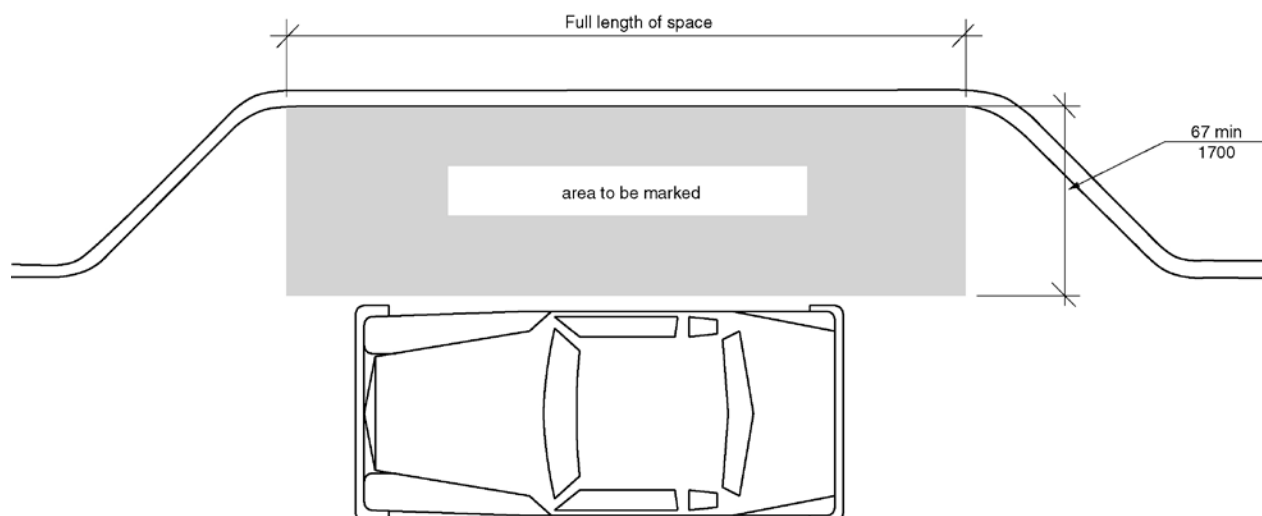
### 503 Passenger Loading Zones

**503.1 General.** **Accessible** passenger loading zones shall comply with Section 503. (ed.)

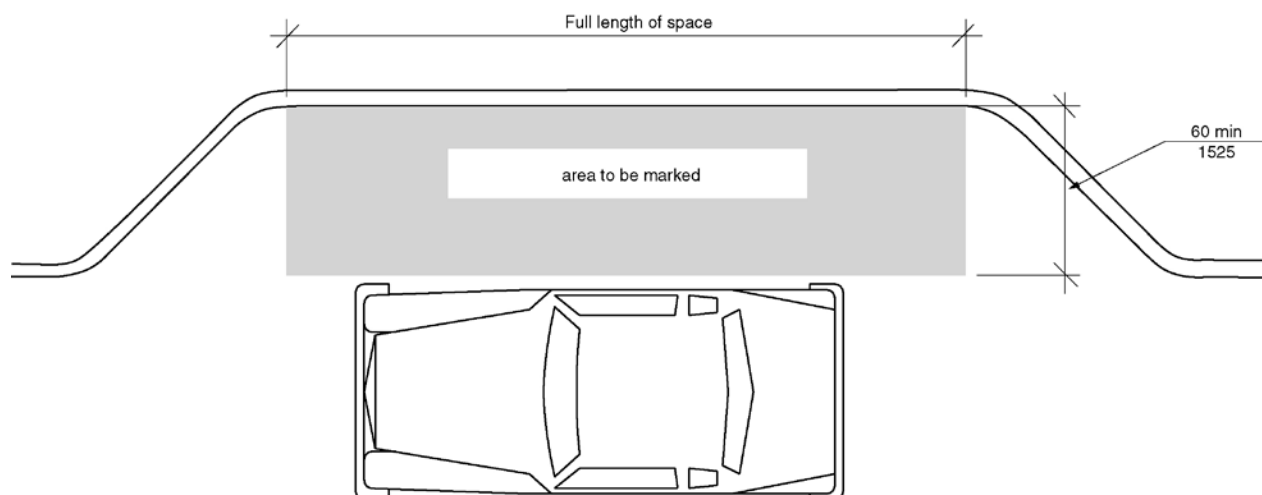
**503.2 Vehicle Pull-up Space Size.** Passenger loading zones shall provide a vehicular pull-up space 96 inches (2440 mm) minimum in width and 20 feet (6100 mm) minimum in length.

**503.3 Access Aisle.** Passenger loading zones shall have an adjacent access aisle complying with Section 503.3.

Figure 503.3 (a) and (b) - Passenger loading zone access aisle



a) new buildings



b) existing buildings

**503.3.1 Location.** Access aisles shall adjoin an accessible route. Access aisles shall not overlap the vehicular way.

**503.3.2 Width.**

**503.3.2.1 New buildings.** In new buildings, aisles serving vehicle pull-up spaces shall be 67 inches (1700 mm) minimum in width. (3-6D-12)

**503.3.2.2 Existing buildings and within new Type B units.** In existing building ~~and serving new Type B units~~, access aisles serving vehicle pull-up spaces shall be 60 inches (1525 mm) minimum in width. (3-6-12 PC2) (ed.)

**503.3.3 Length.** Access aisles shall extend the full length of the vehicle pull-up spaces they serve. (5-8-12)

**503.3.4 Marking.** Access aisles shall be marked so as to discourage parking in them.

**503.4 Floor Surfaces.** Vehicle pull-up spaces and access aisles serving them shall comply with Section 302 and shall have slopes not steeper than 1:48. Access aisles shall be at the same level as the vehicle pull-up space they serve.

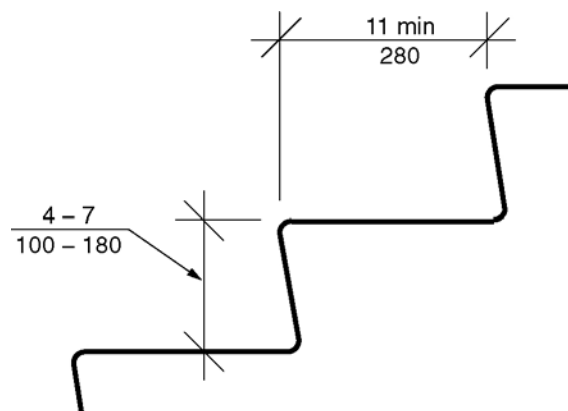
**503.5 Vertical Clearance.** A vertical clearance of 114 inches (2895 mm) minimum shall be provided at the following locations:

1. Vehicle pull-up spaces;
2. The access aisles serving vehicle pull-up spaces;
3. A vehicular route from an entrance to the passenger loading zone, and;
4. A vehicular route from the passenger loading zone to a vehicular exit serving vehicle pull-up spaces.

## 504 Stairways

**504.1 General.** Accessible stairs shall comply with Section 504. (ed.)

**504.2 Treads and Risers.** All steps on a flight of stairs shall have uniform riser height and uniform tread depth. Risers shall be 4 inches (100 mm) minimum and 7 inches (180 mm) maximum in height. Treads shall be 11 inches (280 mm) minimum in depth.



*Figure 504.2 - Treads and risers for stairways*

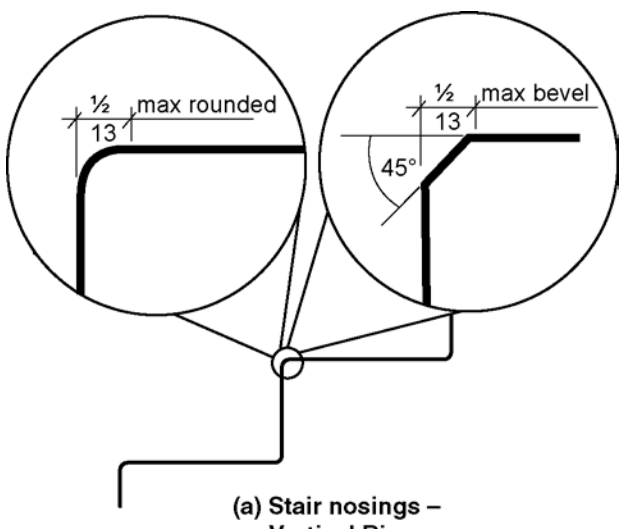
**504.3 Open Risers.** Open risers shall not be permitted.

**504.4 Tread Surface.** Stair treads shall comply with Section 302 and shall have a slope not steeper than 1:48.

**504.5 Nosings.** Nosings shall comply with Section 504.6 and the following: (ed.) (5-11-12)

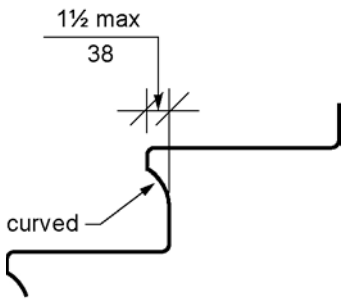
1. Nosings within a stairway shall be uniform.
2. If rounded, the radius of curvature at the leading edge shall be 1/2 inch (13 mm) maximum.
3. If beveled, the bevel at the leading edge shall slope at 45 degrees to the plane of the top surface of the tread and landing and extend for a horizontal distance of 1/2 inch (13 mm) maximum.
4. Nosings that project beyond the risers shall have the underside of the leading edge curved or beveled.
5. Risers shall be permitted to slope under the tread at an angle of 30 degrees maximum from vertical.
6. The permitted projection of the nosing shall be 1 1/2 inches (38 mm) maximum over the tread or floor below. (5-11-12) (ed.)

Figure 504.5 (a) thru (d) - Treads and risers for stairways



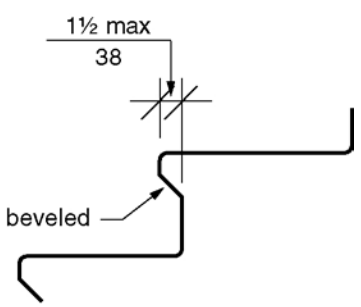
(a) Stair nosings – Vertical Riser

a) vertical riser- curve or bevel at leading edge



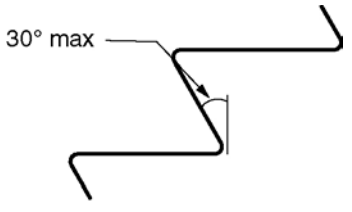
(b) Curved Nosing

b) curved nosing



(c) Beveled Nosing

c) beveled nosing



(d) Angled Riser

d) angled riser

**504.6 Visual contrast.** Visual contrast shall comply with either 1 or 2: (5-13-12 PC1)

1. The leading 1 to 2 inches (51 mm) of every tread and landing, measured horizontally from the leading edge of the nosing, shall consist of a solid color having visual contrast of dark-on-light or light-on-dark from the remainder of the tread. (5-13-12 PC1)

The contrasting marking shall be durable, and shall extend from one side of each tread to the other side of each tread. (5-13-12 PC1)

2. Durable distinctive warning markings required by the adopted building code or ANSI safety standard. (5-13-12 PC1)

**504.7 Handrails.** Stairs shall have handrails complying with Section 505.

**504.8 Wet Conditions.** Stair treads and landings subject to wet conditions shall be designed to prevent the accumulation of water.

**504.9 Lighting.** Lighting for interior stairways shall comply with Section 504.8.

**504.9.1 Illumination Level.** Lighting facilities shall be capable of providing illumination of stairs measured at the center of tread surfaces and on landing surfaces within 24 inches (610 mm) of step nosings- as follows:

1. A 1 foot candle (10.8 lux) minimum illumination at times other than conditions of stair use
2. A 10 foot candle (108 lux) minimum illumination during conditions of stair use
3. The transition from 1 foot candle (10.8 lux) to 10 foot candle (108 lux) under conditions of stair use shall be permitted to be achieved by automatic, motion sensor-type lighting switches provided the switch controllers comply with all of the following:
  - a. The switch controllers are equipped for fail-safe operation and evaluated for this purpose
  - b. The motion sensor is activated by occupant movement on the stair or stair landings
  - c. The illumination timers are set for a minimum 15-minute duration. (5-14-12)

**504.9.2 Lighting Controls.** If provided, occupancy-sensing automatic controls shall activate the stairway lighting so the illuminance level required by Section 504.8.1 is provided on the entrance landing, each stair flight adjacent to the entrance landing, and on the landings above and below the entrance landing prior to any step being used.

**504.10 Tactile Signage within the Stairway Enclosure.** Stair level identification signs in raised characters and braille complying with Sections 703.3 and 703.4 shall be located at each floor level landing in all enclosed stairways adjacent to the door leading from the stairwell into the corridor to identify the floor level. The exit door discharging to the outside or to the level of exit discharge shall have a sign with raised characters and braille stating "EXIT." (5-16-12)

**504.11 Tactile Signage at Exits.** A sign stating EXIT in raised characters and Braille and complying with Sections 703.3 and 703.4 shall be provided adjacent to each door to an area of refuge providing direct access to a stairway, an exterior area for assisted rescue, an exit stairway, an exit ramp, an exit passageway and the exit discharge. (5-16-12) (5-16-12 PC1.1)

## 505 Handrails

**505.1 General.** Handrails required by Section 405.8 for ramps, or Section 504.6 for stairs, shall comply with Section 505.

**505.2 Location.** Handrails shall be provided on both sides of stairs and ramps.

**EXCEPTIONS:**

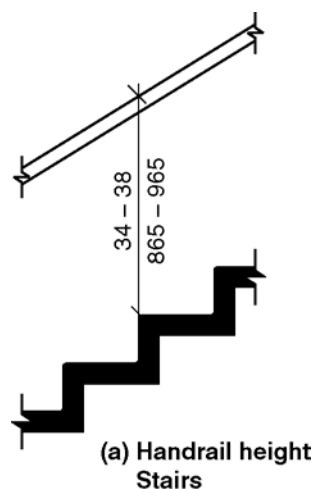
1. In assembly seating areas, handrails shall not be required on both sides along aisle stairs, provided with a handrail either at the side or within the aisle.
2. In assembly seating areas, handrails shall not be required on the sides of ramped aisles serving seats.

**505.3 Continuity.** Handrails shall be continuous within the full length of each stair flight or ramp run. Inside handrails on switchback or dogleg stairs or ramps shall be continuous between flights or runs. Other handrails shall comply with Sections 505.10 and 307.

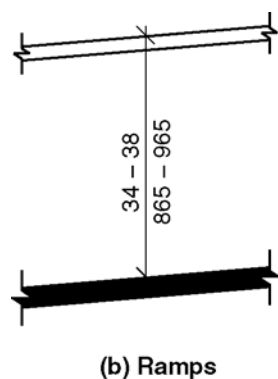
**EXCEPTION:** Handrails shall not be required to be continuous in aisles serving seating where handrails are discontinuous to provide access to seating and to permit crossovers within the aisles.

**505.4 Height.** Top of gripping surfaces of handrails shall be 34 inches (865 mm) minimum and 38 inches (965 mm) maximum vertically above stair nosings, ramp surfaces and walking surfaces. Handrails shall be at a consistent height above stair nosings, ramp surfaces and walking surfaces.

*Figure 505.4(a) and (b) – Handrail Height*



*a) stairs*



*b) ramps*

**505.5 Clearance.** Clearance between handrail gripping surface and adjacent surfaces shall be 1<sup>1</sup>/<sub>2</sub> inches (38 mm) minimum.

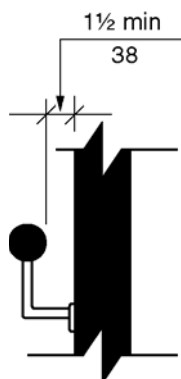


Figure 505.5 – Handrail clearance

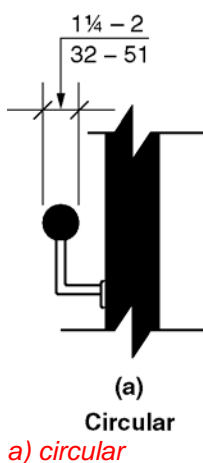
**505.6 Gripping Surface.** Gripping surfaces shall be continuous, without interruption by newel posts, other construction elements, or obstructions.

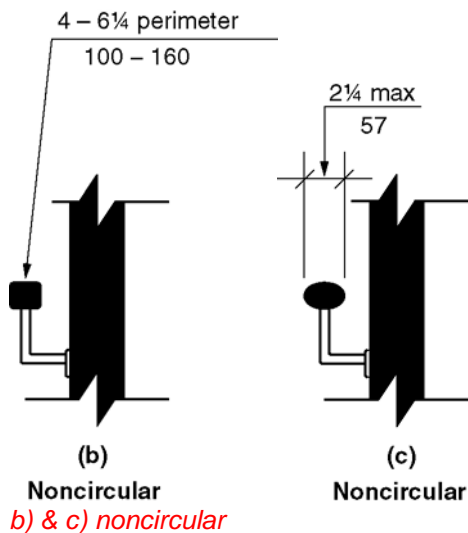
**EXCEPTIONS:**

1. Handrail brackets or balusters attached to the bottom surface of the handrail shall not be considered obstructions, provided the brackets or balusters comply with the following criteria:
  - a. Not more than 20 percent of the handrail length is obstructed,
  - b. Horizontal projections beyond the sides of the handrail occur  $1\frac{1}{2}$  inches (38 mm) minimum below the bottom of the handrail, and provided that for each  $\frac{1}{2}$  inch (13 mm) of additional handrail perimeter dimension above 4 inches (100 mm), the vertical clearance dimension of  $1\frac{1}{2}$  inch (38 mm) shall be permitted to be reduced by  $\frac{1}{8}$  inch (3.2 mm), and
  - c. Edges shall be rounded.
2. Where handrails are provided along walking surfaces with slopes not steeper than 1:20, the bottoms of handrail gripping surfaces shall be permitted to be obstructed along their entire length where they are integral to crash rails or bumper guards.

**505.7 Cross Section.** Handrails shall have a cross section complying with Section 505.7.1 or 505.7.2.

Figure 505.7(a) thru (c) handrail cross section





**505.7.1 Circular Cross Section.** Handrails with a circular cross section shall have an outside diameter of 1¼ inches (32 mm) minimum and 2 inches (51 mm) maximum.

**505.7.2 Noncircular Cross Sections.** Handrails with a noncircular cross section shall have a perimeter dimension of 4 inches (100 mm) minimum and 6¼ inches (160 mm) maximum, and a cross-section dimension of 2¼ inches (57 mm) maximum.

**505.8 Surfaces.** Handrails, and any wall or other surfaces adjacent to them, shall be free of any sharp or abrasive elements. Edges shall be rounded.

**505.9 Fittings.** Handrails shall not rotate within their fittings.

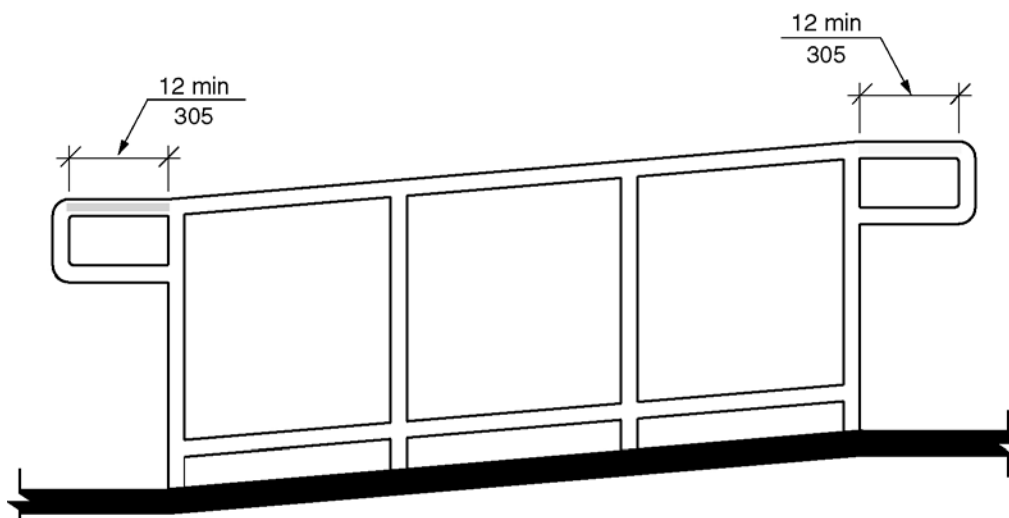
**505.10 Handrail Extensions.** Handrails shall extend beyond and in the same direction of stair flights and ramp runs in accordance with Section 505.10.

**EXCEPTIONS:**

1. Continuous handrails at the inside turn of stairs and ramps.
2. Handrail extensions **shall not be** required in aisles serving seating where the handrails are discontinuous to provide access to seating and to permit crossovers within the aisle.
3. In alterations, full extensions of handrails shall not be required where such extensions would be hazardous due to plan configuration.

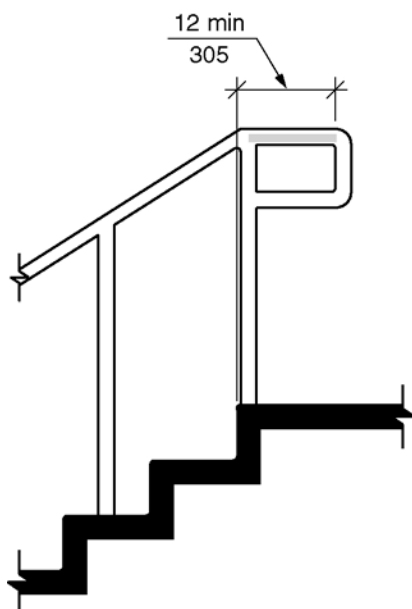
**505.10.1 Top and Bottom Extension at Ramps.** Ramp handrails shall extend horizontally above the landing 12 inches (305 mm) minimum beyond the top and bottom of ramp runs. Extensions shall return to a wall, guard, or floor, or shall be continuous to the handrail of an adjacent ramp run.





*Figure 505.10.1 - Top and bottom handrail extensions at ramps*

**505.10.2 Top Extension at Stairs.** At the top of a stair flight, handrails shall extend horizontally above the landing for 12 inches (305 mm) minimum beginning directly above the landing nosing. Extensions shall return to a wall, guard, or the landing surface, or shall be continuous to the handrail of an adjacent stair flight.



*Figure 505.10.2 - Top handrail extensions at stairs*

**505.10.3 Bottom Extension at Stairs.** At the bottom of a stair flight, handrails shall extend at the slope of the stair flight for a horizontal distance equal to one tread depth beyond the bottom tread nosing. Extensions shall return to a wall, guard, or the landing surface, or shall be continuous to the handrail of an adjacent stair flight.

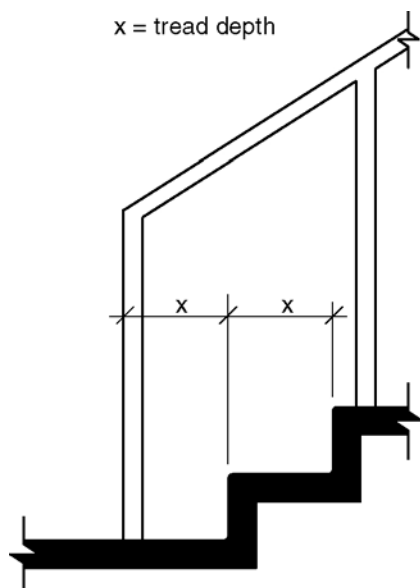


Figure 505.10.3 - Bottom handrail extensions at stairs

## 506 Windows.

**506.1 General.** Where operable **accessible** windows are provided in an accessible room or space, at least one shall **comply with this section**. Where operable windows are required to provide natural ventilation or operable windows are required to provide an emergency escape and rescue openings that window shall be the **accessible** operable window **that complies with this section**. (5-22-12) (ed.)

### EXCEPTIONS:

1. Operable windows that are operated only by employees **shall not be** required to comply with this section.
2. Operable windows in Type A units that comply with Section **1103.13**. (5-22-12)
3. Operable skylights **shall not be** required to comply with this section. (5-22-12) (ed.)

**506.2 Operating force.** The operating force for windows includes forces for opening, closing, locking or latching, and unlocking or unlatching and shall be determined in accordance with AAMA 513 listed in Section **106.2.13**. **Operable parts for locking or latching and unlocking or unlatching shall comply with Section 309**. The operating force for opening and closing operable windows shall be as follows: (5-22-12 PC4.1)

1. 8.5 pounds (37.7 N) maximum for vertical or horizontal sliding windows.
2. 5 pounds (22.2N) maximum for all other types of operating windows. (5-22-12 PC2.1)

## 507 Accessible Routes through Parking.

**507.1 General.** Where accessible routes pass through parking facilities, they shall be physically separated from vehicular traffic.

### EXCEPTIONS:

1. Accessible routes crossings drive aisles shall not be required to comply **with this section**.
2. Accessible routes only from parking spaces complying with Section 502 and passenger loading zones complying with Section 503 to accessible entrances shall not be required to comply with **this section**. (5-23-12 PC1) (ed.)

## Chapter 6. Plumbing Elements and Facilities

### 601 General

**601.1 Scope.** Plumbing elements and facilities required to be accessible by scoping provisions adopted by the administrative authority shall comply with the applicable provisions of Chapter 6.

### 602 Drinking Fountains and Bottle Filling Stations. (6-2-12)

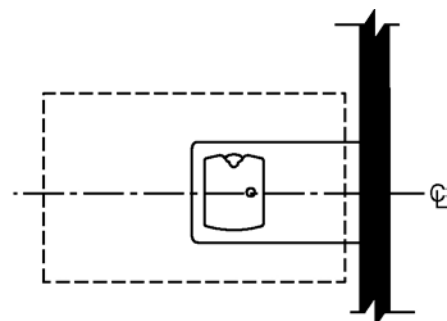
**602.1 General.** Drinking fountains for persons using wheelchairs shall comply with Sections 602.2 and 307. (ed.)

Drinking fountains for standing persons shall comply with Section 602.3 and 307. (6-1-12)

**602.2 Drinking Fountains for Persons Using Wheelchairs.** Drinking fountains for persons using wheelchairs shall comply with Section 602.2.1 through 602.2.5. (6-1-12) (ed.)

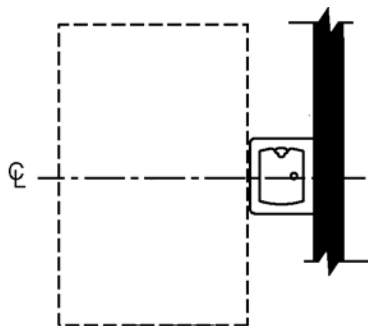
**602.2.1 Clear Floor Space.** A clear floor space complying with Section 305, positioned for a forward approach to the drinking fountain, shall be provided. Knee and toe space complying with Section 306 shall be provided. The clear floor space shall be centered on the drinking fountain.

**EXCEPTION:** Drinking fountains for persons using wheelchairs and primarily for children's use shall be permitted where a parallel approach complying with Section 305 is provided and the clear floor space is centered on the drinking fountain. (6-1-12) (ed.)



(a) Clear floor space at wheelchair drinking fountain – adults

*Figure 602.2.1(a) Clear floor space at drinking fountains for persons using wheelchairs*



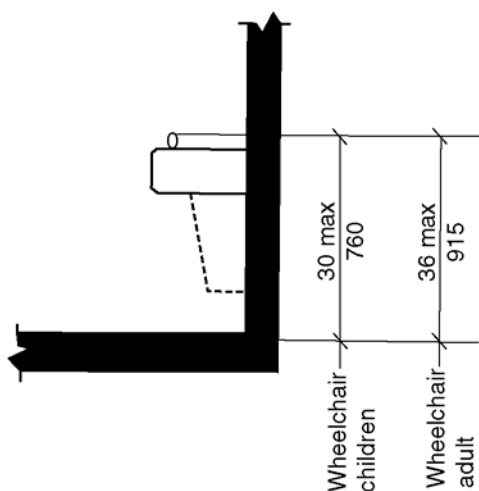
**(b) Clear floor space at wheelchair drinking fountain primarily for children's use – exception**

*Figure 602.2.1(b) Clear floor space as drinking fountains for persons using wheelchairs and primarily for children's use*

**602.2.2 Operable Parts.** Operable parts shall comply with Section 309.

**602.2.3 Spout Outlet Height.** Spout outlets of ~~wheelchair-accessible~~ drinking fountains shall be 36 inches (915 mm) maximum above the floor. (ed.)

**EXCEPTION:** At drinking fountains for persons using wheelchairs and primarily for children's use, the spout outlet shall be 30 inches (760 mm) maximum above the floor. (6-1-12) (ed.)



*Figure 602.2.3 Spout height and location at drinking fountain for persons using wheelchairs*

**602.2.4 Spout Location.** The spout shall be located 15 inches (380 mm) minimum from the vertical support and 5 inches (125mm) maximum from the front edge of the drinking fountain, including bumpers.

**EXCEPTION:** At drinking fountains primarily for children's use, the spout shall be located 3 1/2 inches (89 mm) maximum from the front edge of the drinking fountain, including bumpers. (6-1-12)

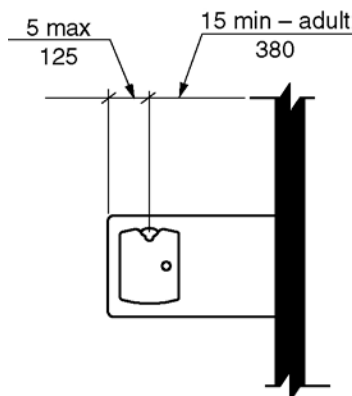


Figure 602.2.4 Spout location at drinking fountains for persons using wheelchairs

**602.2.5 Water Flow.** The spout shall provide a flow of water 4 inches (100 mm) minimum in height. The angle of the water stream from spouts within 3 inches (76 mm) of the front of the drinking fountain shall be 30 degrees maximum, and from spouts between 3 inches (76 mm) and 5 inches (125 mm) from the front of the drinking fountain shall be 15 degrees maximum, measured horizontally relative to the front face of the drinking fountain.

**602.3 Drinking fountains for persons who are standing.** Drinking fountains for persons who are standing shall comply with Section 602.3.1 through 602.3.4. (6-1-12) (ed.)

**602.3.1 Operable Parts.** Operable parts shall comply with Section 309.3 and 309.4. (6-1-12)

**602.3.2 Spout Outlet Height.** Spout outlets of drinking fountains ~~for standing persons~~ shall be 38 inches (965 mm) minimum and 43 inches (1090 mm) maximum above the floor. (6-1-12) (ed.)

**EXCEPTION:** Drinking fountains for persons who are standing and primarily for children's use shall be permitted where the spout outlet is 30 inches (760 mm) minimum and 43 inches (1090 mm) maximum above the floor. (ed.) (6-1-12)

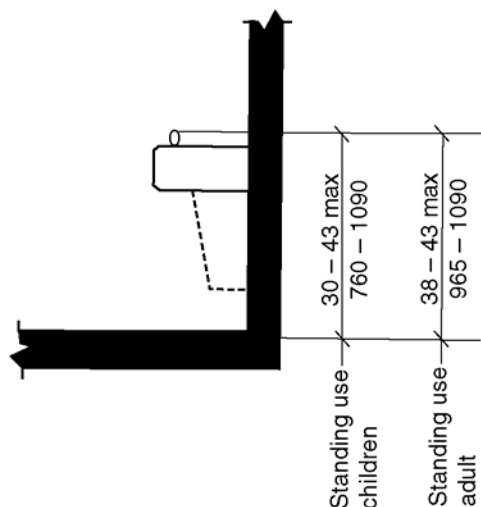


Figure 602.3.2 – Spout height and location at drinking fountains for persons who are standing

**602.3.3 Spout location.** The spout shall be located 5 inches (125 mm) maximum from the front edge of the drinking fountain, including bumpers. (6-1-12)

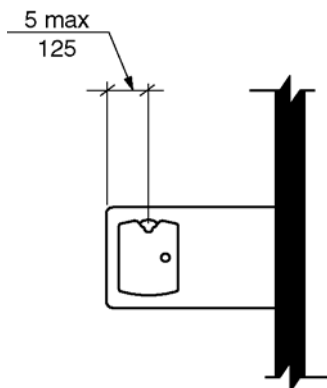


Figure 602.3.3 – Spout location at drinking fountains for persons who are standing

**602.3.4 Water Flow.** The spout shall provide a flow of water 4 inches (100 mm) minimum in height. The angle of the water stream from spouts within 3 inches (76 mm) of the front of the drinking fountain shall be 30 degrees maximum, and from spouts between 3 inches (76 mm) and 5 inches (125 mm) from the front of the drinking fountain shall be 15 degrees maximum, measured horizontally relative to the front face of the drinking fountain. (6-1-12)

**602.4 Bottle Filling Stations.** Bottle filling stations which shall comply with Sections 602.4.1 and 602.4.2.

**Exception:** Where bottle filling stations are part of the drinking fountain for persons who are standing, the bottle filling station is not required to comply with this section provided a bottle filling station is located at the wheelchair-accessible drinking fountain for persons using wheelchairs. (6-2-12) (ed.)

**602.4.1 Clear Floor Space.** A clear floor space complying with Section 305, positioned for a forward or side approach, shall be provided. (6-2-12)

**602.4.2 Controls.** Controls for bottle filling stations shall be hand operated or automatic. Hand operated controls shall comply with Section 309. (6-2-12)

## 603 Toilet and Bathing Rooms

**603.1 General.** Accessible toilet and bathing rooms shall comply with Section 603. (ed.)

### 603.2 Clearances.

**603.2.1 Turning Space.** A turning space complying with Section 304 shall be provided within the room. The required turning space shall not be provided within a toilet compartment.

**603.2.2 Door Swing.** Doors shall not swing into the clear floor space or clearance for any fixture.

#### EXCEPTIONS:

1. Doors to a toilet or bathing room for a single occupant, accessed only through a private office and not for common use or public use shall be permitted to swing into the clear floor space, provided the swing of the door can be reversed to comply with Section 603.2.2.
2. Where the room is for individual use and a clear floor space complying with Section 305.3 is provided within the room beyond the arc of the door swing, the door shall not be required to comply with Section 603.2.2.

**603.3 Mirrors.** Where mirrors are located above lavatories, a mirror shall be located over the **accessible** lavatory **complying with Section 606** and shall be mounted with the bottom edge of the reflecting surface 40 inches (1015 mm) maximum above the floor. Where mirrors are located above counters that do not contain lavatories, the mirror shall be mounted with the bottom edge of the reflecting surface 40 inches (1015 mm) maximum above the floor. (ed.)

**EXCEPTION:** Other than within Accessible dwelling or sleeping units, mirrors **shall not be** required over the lavatories or counters if a mirror is located within the same toilet or bathing room and mounted with the bottom edge of the reflecting surface 35 inches (890 mm) maximum above the floor. (ed.)

**603.4 Coat Hooks and Shelves.** Coat hooks shall be located within one of the reach ranges specified in Section 308. Shelves shall be 40 inches (1015 mm) minimum and 48 inches (1220 mm) maximum above the floor.

**603.5 Diaper Changing Tables.** Diaper changing tables shall comply with Sections 309 and 902

**603.6 Operable Parts.** Operable parts on towel dispensers and hand dryers serving **accessible** lavatories **complying with Section 606** shall comply with Table 603.6. (ed.)

**Table 603.6**  
**Maximum Reach Depth and Height**

<b>Maximum Reach Depth</b>	0.5 inch (13 mm)	2 inches (50 mm)	5 inches (125 mm)	6 inches (150 mm)	9 inches (230 mm)	11 inches (280 mm)
<b>Maximum Reach Height</b>	48 inches (1220 mm)	46 inches (1170 mm)	42 inches (1065 mm)	40 inches (1015 mm)	36 inches (915 mm)	34 inches (865 mm)

#### **604 Water Closets and Toilet Compartments**

**604.1 General.** **Accessible** water closets and toilet compartments shall comply with Section 604. Compartments containing more than one plumbing fixture shall comply with Section 603. Wheelchair **accessible toilet** compartments shall comply with Section 604.9. Ambulatory **accessible toilet** compartments shall comply with Section 604.10. (ed.)

**EXCEPTION:** Water closets and toilet compartments primarily for children's use shall be permitted to comply with Section 604.11 as applicable.

**604.2 Location.** The water closet shall be located with a wall or partition to the rear and to one side. The centerline of the water closet shall be 16 inches (405 mm) minimum and 18 inches (455 mm) maximum from the side wall or partition. Water closets located in **ambulatory accessible toilet** compartments specified in Section 604.10 shall have the centerline of the water closet 17 inches (430 mm) minimum and 19 inches (485 mm) maximum from the side wall or partition. (ed.)

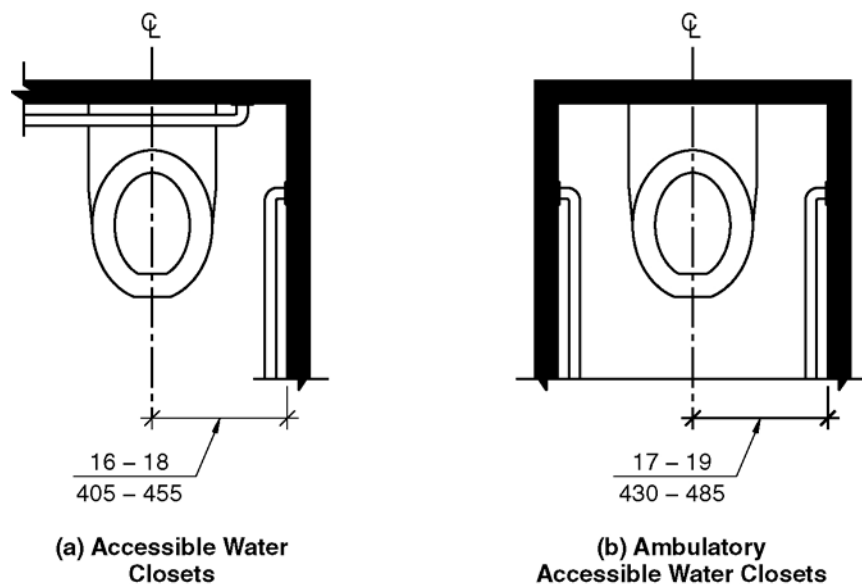


Figure 604.2 Water closet location

### 604.3 Clearance.

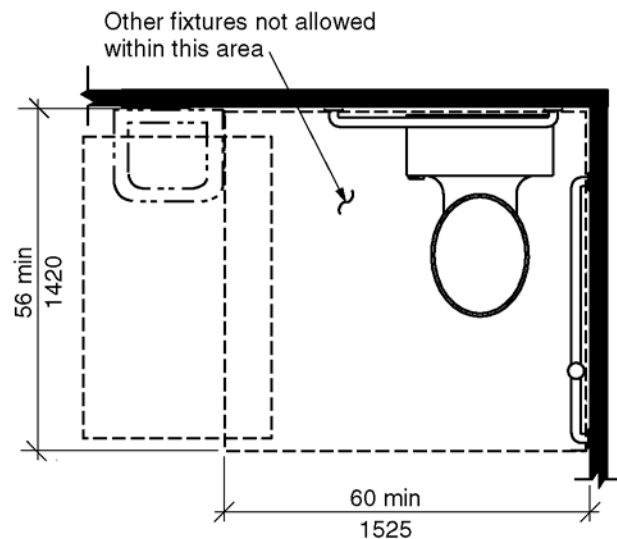


Figure 604.3 Size of clearance for water closet

**604.3.1 Clearance width.** A clearance around a water closet shall be 60 inches (1525 mm) minimum in width, measured perpendicular from the sidewall.

**604.3.2 Clearance Depth.** Clearance around the water closet shall be 56 inches (1420 mm) minimum in depth, measured perpendicular from the rear wall.

**604.3.3 Clearance Overlap.** The required clearance around the water closet shall be permitted to overlap the water closet, associated grab bars, paper dispensers, sanitary napkin receptacles, coat hooks, shelves, accessible routes, clear floor space at other fixtures and the turning space. No other fixtures or obstructions shall be within the required water closet clearance.

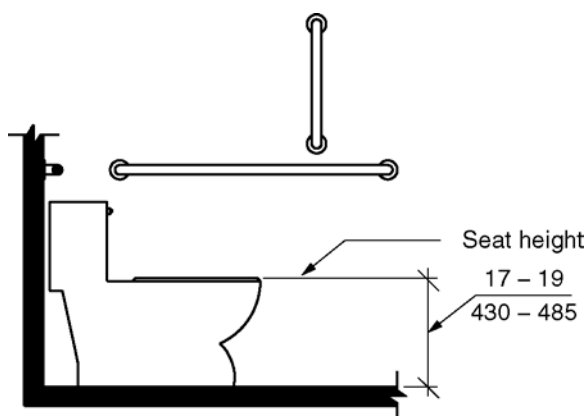
**604.4 Height.** The height of water closet seats shall be 17 inches (430 mm) minimum and 19 inches (485 mm) maximum above the floor, measured to the top of the seat. Seats shall not be sprung to return to a



lifted position.

#### EXCEPTIONS:

1. An ~~accessible-A~~ water closet which is adjustable in height by the user is permitted provided that at least one adjustment setting provides a seat within the range specified in Section 604.4. (6-5-12) (ed.)
2. A water closet in a toilet room for a single occupant, accessed only through a private office and not for common use or public use, shall not be required to comply with Section 604.4



Note: For children's dimensions see Fig. 604.11.4

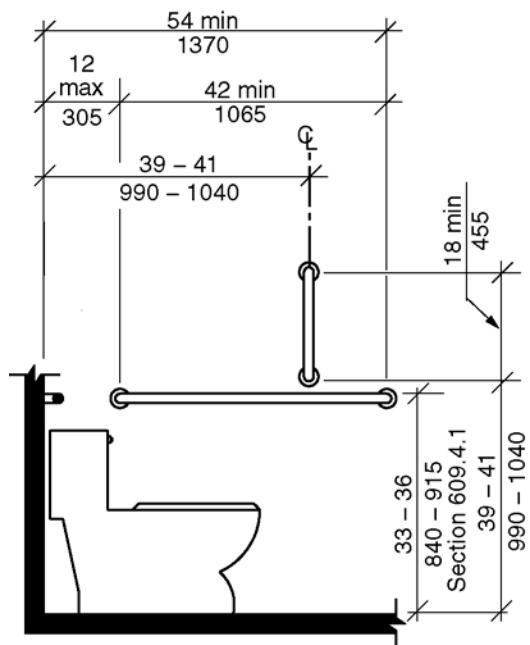
*Figure 604.4 - Water closet seat height*

**604.5 Grab Bars.** Grab bars for water closets shall comply with Section 609 and shall be provided in accordance with Sections 604.5.1 and 604.5.2. Grab bars shall be provided on the rear wall and on the side wall closest to the water closet.

#### EXCEPTIONS:

1. Grab bars shall not be required to be installed in a toilet room for a single occupant, accessed only through a private office and not for common use or public use, provided reinforcement has been installed in walls and located so as to permit the installation of grab bars complying with Section 604.5. (ed.)
2. In detention or correction facilities, grab bars shall not be required to be installed in housing or holding cells or rooms that are specially designed without protrusions for purposes of suicide prevention. (ed.)

**604.5.1 Fixed Side Wall Grab Bars.** Fixed side wall grab bars shall include a horizontal bar complying with Section 604.5.1.1 and a vertical grab bar complying with Section 604.5.1.2. The vertical grab bar at water closets primarily for children's use shall comply with Section 609.4.2. (6-7-12)



Note: For children's dimensions see Fig. 609.4.2

*Figure 604.5.1 - Side wall grab bar for water closet*

**604.5.1.1 Horizontal Grab Bar.** A horizontal grab bar 42 inches (1065 mm) minimum in length shall be located 12 inches (305 mm) maximum from the rear wall and extend 54 inches (1370 mm) minimum from the rear wall. (6-7-12)

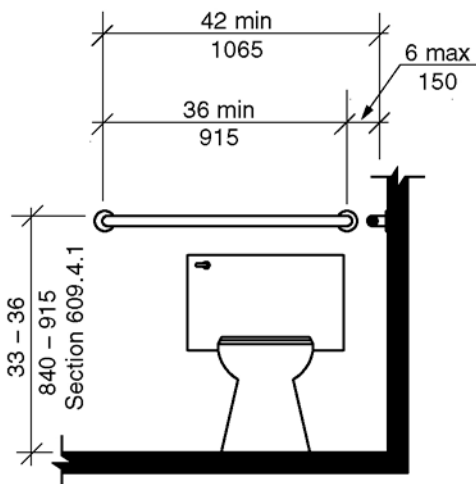
**604.5.1.2 Vertical Grab Bar.** A vertical grab bar 18 inches (455 mm) minimum in length shall be mounted with the bottom of the bar located 39 inches (990 mm) minimum and 41 inches (1040 mm) maximum above the floor, and with the center line of the bar located 39 inches (990 mm) minimum and 41 inches (1040 mm) maximum from the rear wall. (6-7-12)

**604.5.2 Rear Wall Grab Bars.** The fixed rear wall grab bar shall be:

1. 36 inches (915 mm) minimum in length,
2. Located 6 inches maximum (150 mm) from the side wall, and
3. Extend 42 inches (1065 mm) minimum from the side wall. (6-10-12)

**EXCEPTIONS:**

1. The rear grab bar shall be permitted to be 24 inches (610 mm) minimum in length, centered on the water closet, where wall space does not permit a grab bar 36 inches (915 mm) minimum in length due to the location of a recessed fixture adjacent to the water closet.
2. Where an administrative authority requires flush controls for flush valves to be located in a position that conflicts with the location of the rear grab bar, that grab bar shall be permitted to be split or shifted to the open side of the toilet area.



Note: For children's dimensions see Fig. 609.4.2

*Figure 604.5.2 - Rear wall grab bar for water closet*

**604.6 Flush Controls.** Flush controls shall be hand operated or automatic. Hand operated flush controls shall comply with Section 309. Flush controls shall be located on the open side of the water closet.

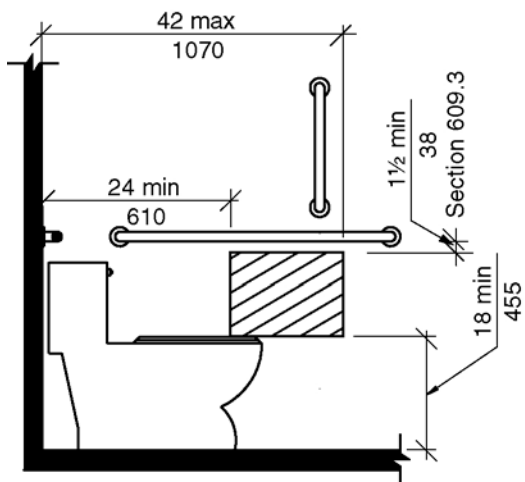
**EXCEPTION:** In ambulatory **accessible-toilet** compartments complying with Section 604.10, flush controls shall be permitted to be located on either side of the water closet. (ed.)

**604.7 Dispensers.** Toilet paper dispensers shall comply with Section 309.4. Dispensers shall comply with Section 609.3. Dispensers shall not be of a type that control delivery, or do not allow continuous paper flow. (6-14-12 PC2)

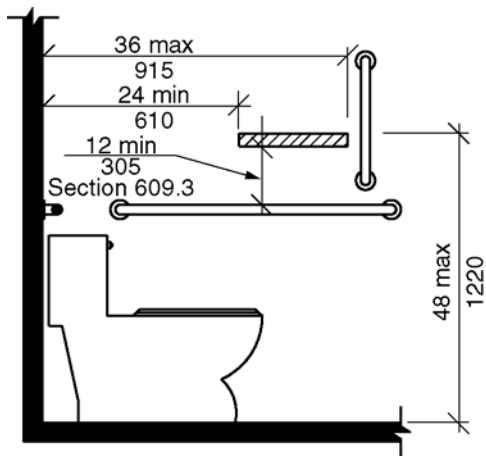
**604.7.1 Location.** Where the dispenser is located above the grab bar, the outlet of the dispenser shall be located within an area 24 inches (610 mm) minimum and 36 inches (915 mm) maximum from the rear wall. Where the dispenser is located below the grab bar, the outlet of the dispenser shall be located within an area 24 inches (610 mm) minimum and 42 inches (1065 mm) maximum from the rear wall. The outlet of the dispenser shall be located 18 inches (455 mm) minimum and 48 inches (1220 mm) maximum above the floor. (6-14-12 PC2)

**EXCEPTION:** Toilet paper dispensers that accommodate a maximum of 2 toilet paper rolls of not more than 5 inch (125 mm) diameter each shall be permitted to be located 7 inches (180 mm) minimum and 9 inches (230 mm) maximum in front the of the water closet measured to the centerline of the dispenser. The outlet of the dispenser shall be 15 inches (380 mm) minimum and 48 inches (1220 mm) maximum above the floor. (6-14-12) (6-14-12 PC2)

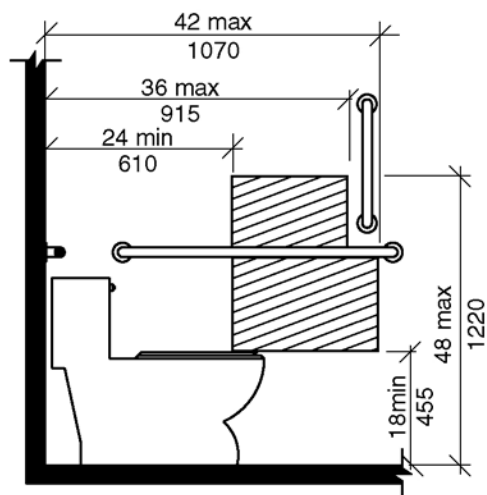
*Figure 604.7.1(a) thru (d) dispenser outlet location*



**(a) Dispenser outlet location –  
Protruding Dispenser Below Grab Bar**  
*a) Protruding dispenser below grab bar*



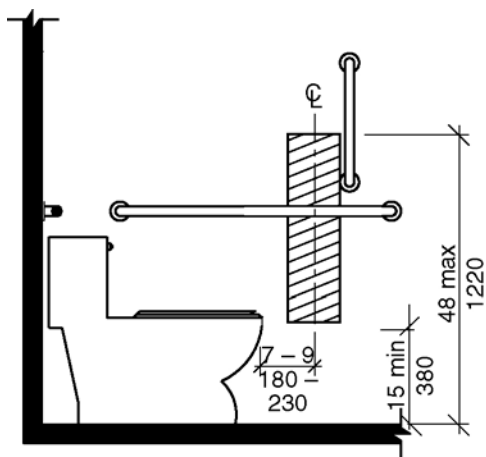
**(b) Protruding Dispenser Above Grab Bar**  
*b) Protruding dispenser above grab bar*



(c) Recessed Dispenser

Note: For children's dimensions see Fig. 604.11.7 dispenser outlet location

*c) Recessed dispenser*



(d) Dispenser in front of water closet

*d) Dispenser in front of water closet - exception*

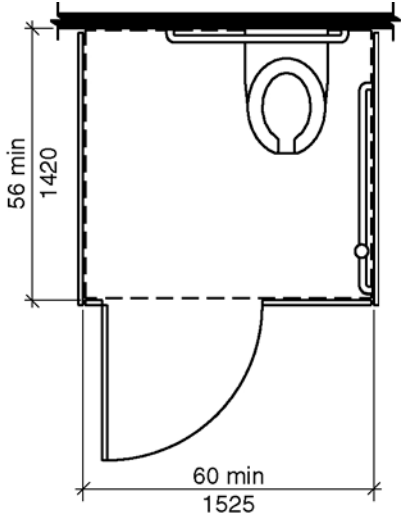
**604.8 Coat Hooks and Shelves.** Coat hooks provided within toilet compartments shall be 48 inches (1220 mm) maximum above the floor. Shelves shall be 40 inches (1015 mm) minimum and 48 inches (1220 mm) maximum above the floor.

#### 604.9 Wheelchair **Accessible Toilet** Compartments.

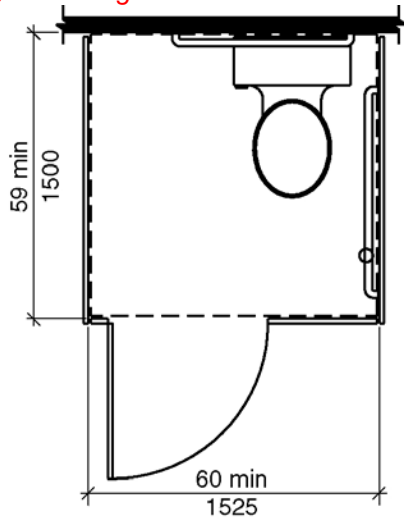
**604.9.1 General.** Wheelchair **accessible toilet** compartments shall comply with Section 604.9.

**604.9.2 Size.** **Wheelchair accessible toilet** Compartments shall comply with Section 604.9.2.1, 604.9.2.2 or 604.9.2.3 as applicable.

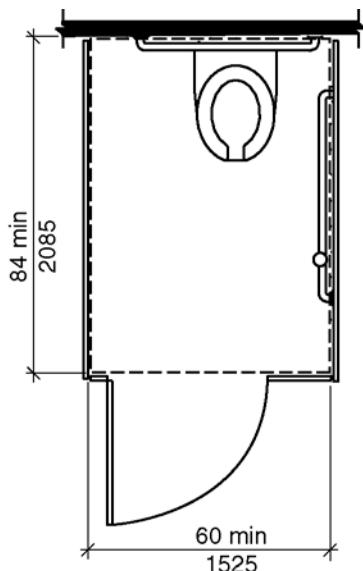
*Figure 604.9.2(a) thru (c) – Wheelchair **accessible toilet** compartments*



**(a) Wall-Hung Water Closet – Adult**  
*a) Wall hung closet - adult*



**(b) Floor-Mounted Water Closet – Adult**  
**Wall-Hung and**  
**Floor-Mounted Water Closet – Children**  
*b) Floor mounted water closet – adult; Wall hung and floor mounted water closet – children*



**(c) Alternate Wheelchair Toilet Compartment**

*c) Alternate wheelchair accessible toilet compartment*

**604.9.2.1 Minimum area.** The minimum area of a **wheelchair accessible toilet** compartment shall be 60 inches (1525 mm) minimum in width measured perpendicular to the side wall, and 56 inches (1420 mm) minimum in depth for wall hung water closets, and 59 inches (1500 mm) minimum in depth for floor mounted water closets measured perpendicular to the rear wall. (ed.)

**604.9.2.2 Compartment for children's use.** The minimum area of a **wheelchair accessible toilet** compartment primarily for children's use shall be 60 inches (1525 mm) minimum in width measured perpendicular to the side wall, and 59 inches (1500 mm) minimum in depth for wall hung and floor mounted water closets measured perpendicular to the rear wall. (ed.)

**604.9.2.3 Alternate wheelchair accessible toilet Compartments.** Where an alternate wheelchair accessible toilet compartment is provided, the minimum area of the compartment shall be 60 inches (1525 mm) minimum in width, measured perpendicular to the side wall, and 84 inches (2135 mm) minimum in depth, measured perpendicular to the rear wall. (6-18-12) (ed.)

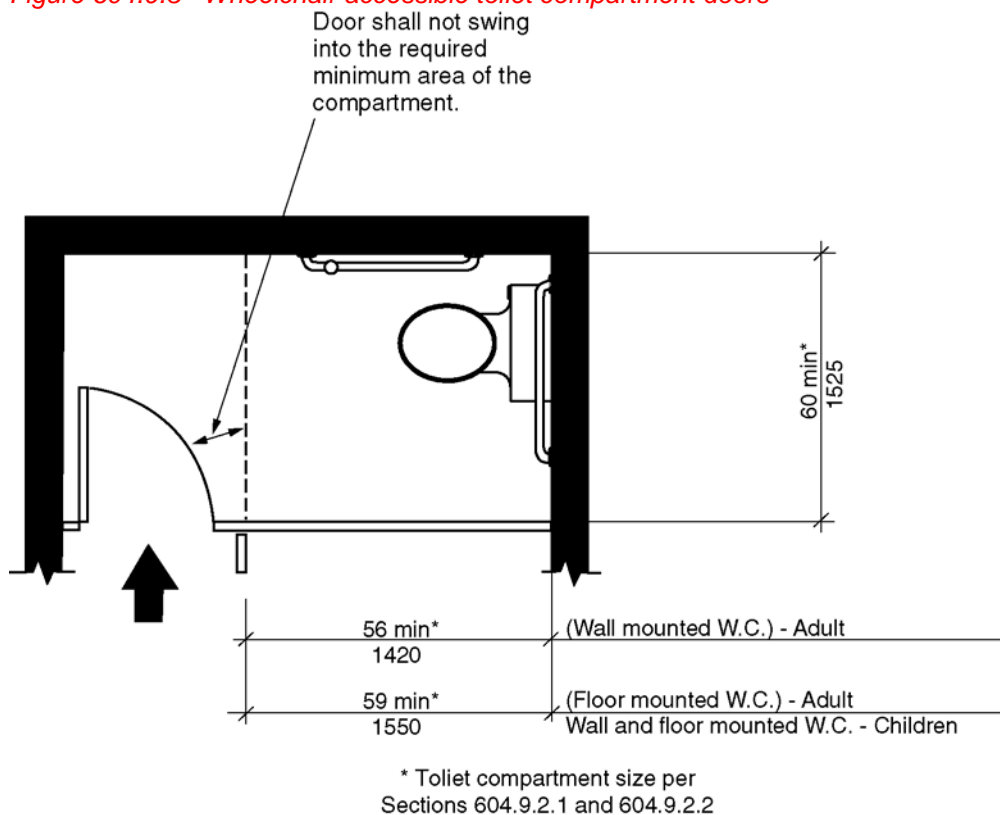
**604.9.3 Doors.** **Wheelchair accessible toilet** compartment doors, including door hardware, shall comply with Section 404. The door shall be self-closing. A door pull complying with Section 404.2.6 shall be placed on both sides of the door near the latch. **Wheelchair accessible toilet** compartment doors shall not swing into the required minimum area of the compartment. (6-19-12) (ed.)

**EXCEPTIONS:**

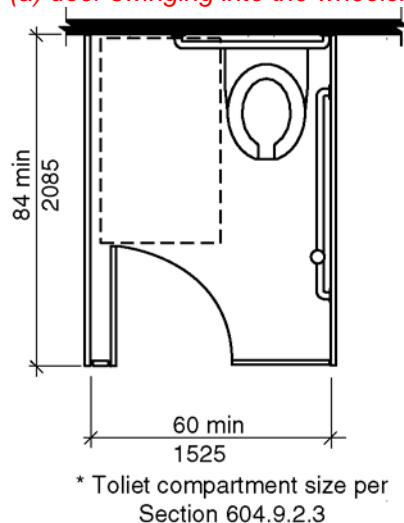
1. Outside of the compartment, where the approach is to the latch side of the **wheelchair accessible toilet** compartment door clearance between the door side of the compartment and any obstruction shall be 42 inches (1065 mm) minimum. (6-19-12) (ed.)
2. Within the **wheelchair accessible toilet** compartment, maneuvering clearances at the door shall not be required to comply with Section 404. (6-19-12) (ed.)
3. In an alternate **wheelchair accessible toilet** compartment, the door ~~can~~ shall be permitted to

swing into the stall where a clear floor space complying with Section 305.3 is provided within the stall beyond the arc of the door swing. (6-18-12) (ed.)

Figure 604.9.3– Wheelchair accessible toilet compartment doors



(a) door swinging into the wheelchair accessible toilet compartment

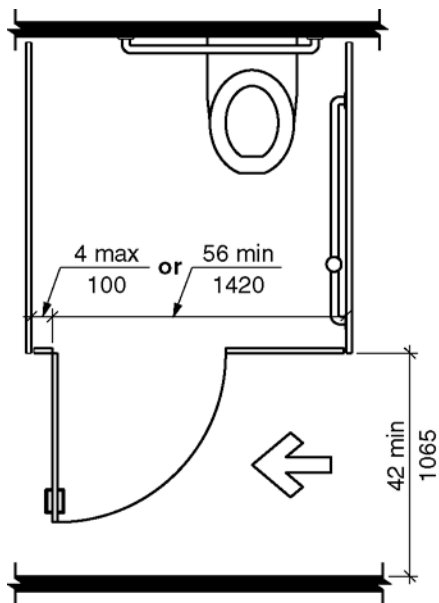


(b) Exception 3 – alternate wheelchair accessible toilet compartment

**604.9.3.1 Door Opening Location.** The farthest edge of the wheelchair accessible toilet compartment door opening shall be located in the front wall or partition or in the side wall or partition as required by Table 604.9.3.1. (ed.)

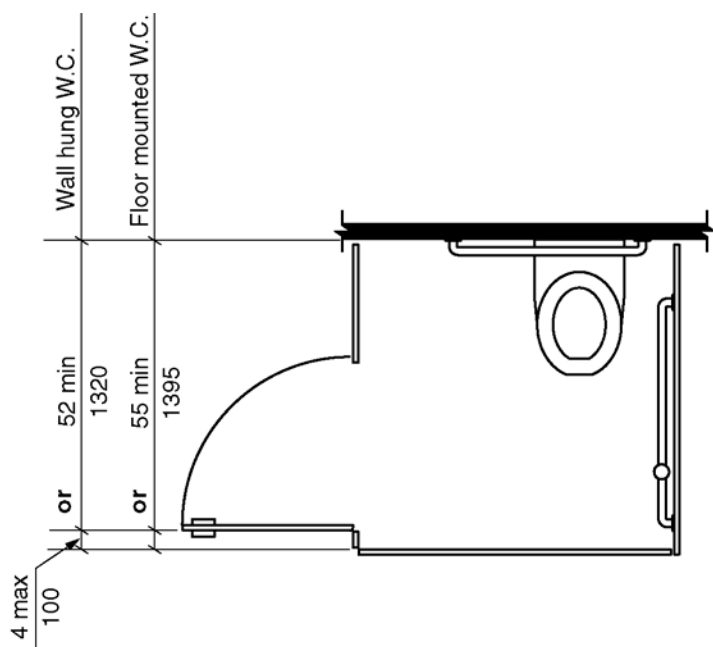
Figure 604.9.3.1– Wheelchair accessible toilet compartment door opening locations





(a) Door swing in on Front wall of partition

*(a) door swinging out on front wall of partition*



(b) Door swing in on Side wall of partition

*(b) door swinging out on side wall of partition*

**Table 604.9.3.1 – Door Opening Location**

Door Opening Location	Measured From	Dimension
<b>Front Wall or Partition</b>	From the side wall or partition closest to the water closet	56 inches (1420 mm) minimum
	From the side wall or partition	4 inches (100 mm) maximum

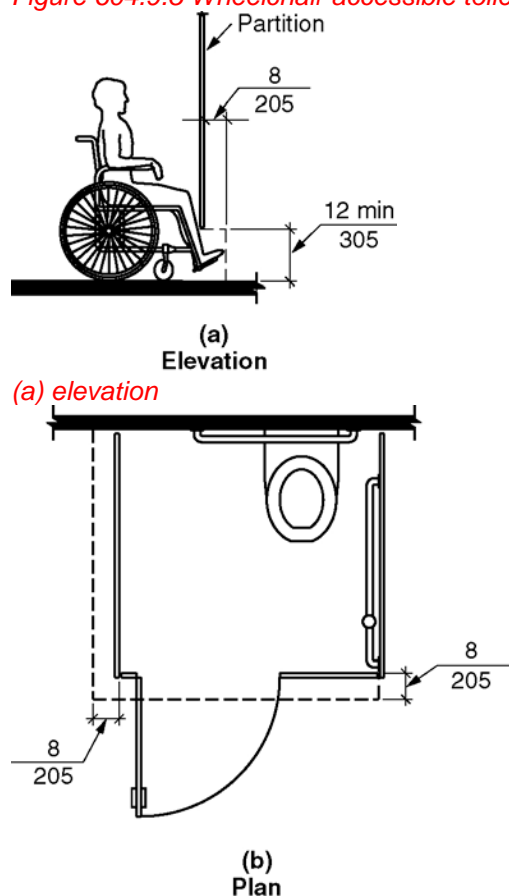
	farthest from the water closet	
<b>Side Wall or Partition</b>	From the rear wall	52 inches (1320 mm) minimum
		Or
<b>Wall-Hung Water Closet</b>	From the front wall or partition	4 inches (100 mm) maximum
<b>Side Wall or Partition</b>	From the rear wall	55 inches (1395 mm) minimum
		Or
<b>Floor-Mounted Water Closet</b>	From the front wall or partition	4 inches (100 mm) maximum

(6-20-12) (6-20-12 PC2.1)

**604.9.4 Approach.** Wheelchair accessible toilet compartments shall be arranged for left-hand or right-hand approach to the water closet.

**604.9.5 Toe Clearance at Accessible Compartments.** Toe clearance for wheelchair accessible toilet compartments primarily for children's use shall comply with Section 604.9.5.2. Toe clearance for other wheelchair accessible toilet compartments shall comply with Section 604.9.5.1. (6-22-12) (ed.)

Figure 604.9.5 Wheelchair accessible toilet compartment toe clearance



(b) plan

**604.9.5.1 Toe Clearance at Wheelchair Accessible Toilet Compartments.** The front partition and at least one side partition of wheelchair accessible toilet compartments shall provide a toe clearance of 12 inches (305 mm) minimum above the floor and extending 8 inches (205 mm) beyond the compartment side face of the partition, exclusive of partition support members. (6-22-12) (ed.)

#### EXCEPTIONS:

1. Toe clearance at the front partition is not required in a **wheelchair accessible toilet** compartment greater than 64 inches (1625 mm) in depth with a wall-hung water closet, or greater than 67 inches (1700 mm) in depth with a floor-mounted water closet. (6-22-12)
2. Toe clearance at the side partition is not required in a **wheelchair accessible toilet** compartment greater than 68 inches (1730 mm) in width. (6-22-12) (ed.)

**604.9.5.2 Toe Clearance at Wheelchair accessible Toilet Compartments for Children's Use.** The front partition and at least one side partition of **wheelchair accessible toilet** compartments primarily for children's use shall provide a toe clearance of 12 inches (305 mm) minimum above the floor and extending 8 inches (205 mm) beyond the **wheelchair accessible toilet** compartment side face of the partition, exclusive of partition support members. (6-22-12) (ed.)

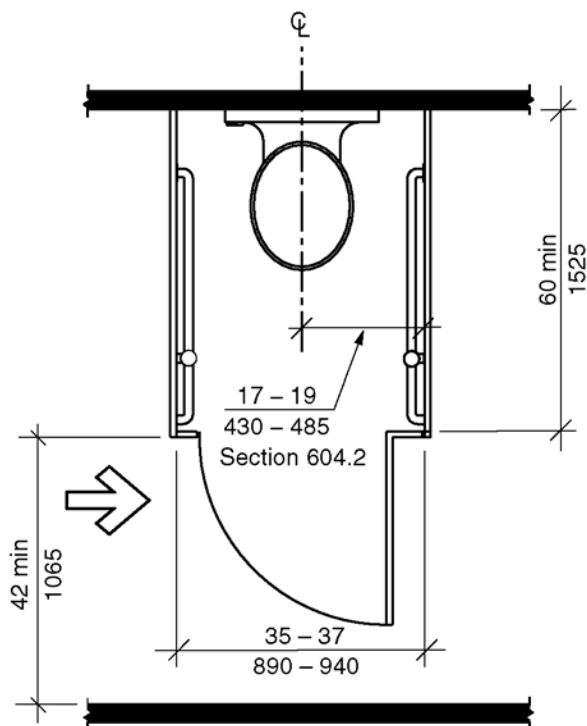
**EXCEPTIONS:**

1. Toe clearance at the front partition is not required in a **wheelchair accessible toilet** compartment greater than 67 inches (1700 mm) in depth. (6-22-12)
2. Toe clearance at the side partition is not required in a **wheelchair accessible toilet** compartment greater than 68 inches (1730 mm) in width. (6-22-12) (ed.)

**604.9.6 Grab Bars.** Grab bars shall comply with Section 609. Side wall grab bars complying with Section 604.5.1 located on the wall closest to the water closet, and a rear wall grab bar complying with Section 604.5.2, shall be provided.

**604.10 Ambulatory Accessible Toilet Compartments.**

**604.10.1 General.** Ambulatory **accessible toilet** compartments shall comply with Section 604.10. (ed.)



*Figure 604.10.1 Ambulatory accessible toilet compartment*

**604.10.2 Size.** The minimum area of an ambulatory accessible toilet compartment shall be 60 inches (1525 mm) minimum in depth and a width of 35 inches (890 mm) minimum and 37 inches (940 mm) maximum. (6-24-12) (ed.)

**604.10.3 Doors.** Ambulatory accessible toilet Compartment doors, including door hardware, shall comply with Section 404. The door shall be self-closing. A door pull complying with Section 404.2.6 shall be placed on both sides of the door near the latch. Compartment doors shall not swing into the required minimum area of the compartment. (6-19-12) (ed.)

**EXCEPTIONS:**

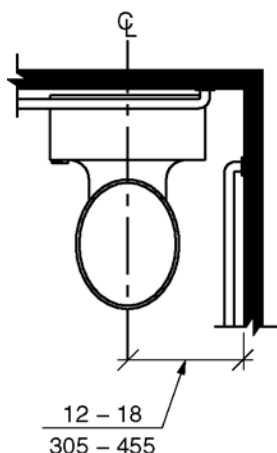
1. Outside of the ambulatory accessible toilet compartment, where the approach is to the latch side of the compartment door, clearance between the door side of the compartment and any obstruction shall be 42 inches (1065 mm) minimum. (6-19-12) (ed.)
2. Within the ambulatory accessible toilet compartment, maneuvering clearances at the door shall not be required to comply with Section 404. (6-19-12) (ed.)

**604.10.4 Grab Bars.** Grab bars shall comply with Section 609. Side wall grab bars complying with Section 604.5.1 shall be provided on both sides of the compartment.

**604.11 Water Closets and Toilet Compartments for Children's Use.**

**604.11.1 General.** Accessible water closets and wheelchair and ambulatory accessible toilet compartments primarily for children's use shall comply with Section 604.11. (ed.)

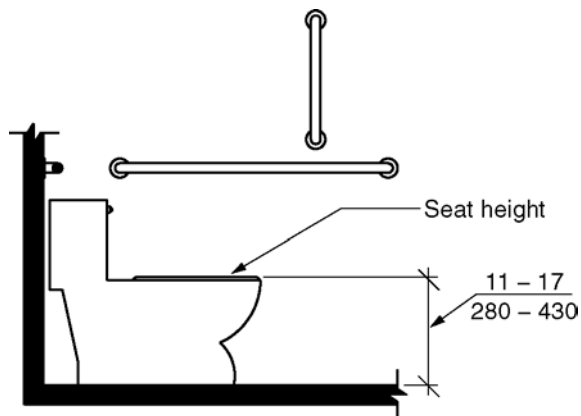
**604.11.2 Location.** The water closet primarily for children's use shall be located with a wall or partition to the rear and to one side. The centerline of the water closet shall be 12 inches (305 mm) minimum and 18 inches (455 mm) maximum from the side wall or partition. Water closets located in ambulatory accessible toilet compartments specified in Section 604.10 shall be located as specified in Section 604.2. (6-24-12 PC1)



*Figure 604.11.2 Children's water closet location*

**604.11.3 Clearance.** A clearance around the water closet primarily for children's use complying with Section 604.3 shall be provided. (ed.)

**604.11.4 Height.** The height of water closet seats primarily for children's use shall be 11 inches (280 mm) minimum and 17 inches (430 mm) maximum above the floor, measured to the top of the seat. Seats shall not be sprung to return to a lifted position. (ed.)



Note: For adult dimensions see Fig. 604.4

*Figure 604.11.4 Children's water closet height*

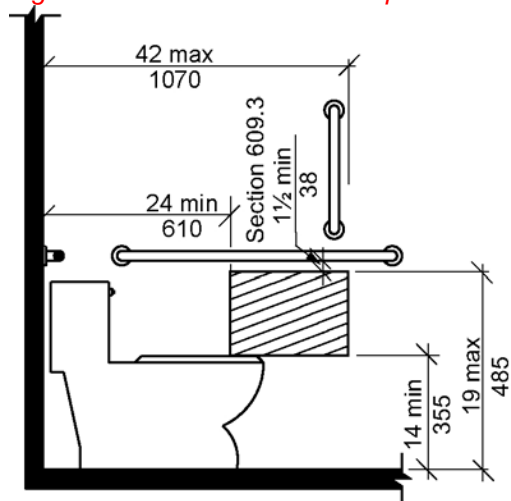
**604.11.5 Grab Bars.** Grab bars for water closets **primarily for children's use** shall comply with Section 604.5. (ed.)

**604.11.6 Flush Controls.** Flush controls **primarily for children's use** shall be hand operated or automatic. Hand operated flush controls shall comply with Sections 309.2 and 309.4 and shall be installed 36 inches (915 mm) maximum above the floor. Flush controls shall be located on the open side of the water closet.

**EXCEPTION:** In ambulatory **accessible toilet** compartments complying with Section 604.10, flush controls shall be permitted to be located on either side of the water closet. (ed.)

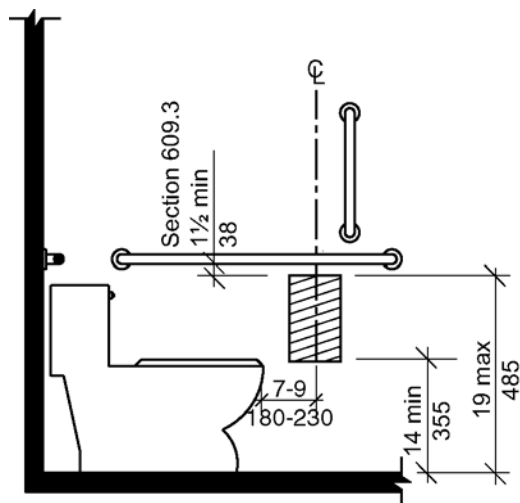
**604.11.7 Dispensers.** Toilet paper dispensers **primarily for children's use** shall comply with Section 309.4. **There shall be a clearance of 1 1/2 inches (38 mm) minimum below the grab bar.** Dispensers shall not be of a type that control delivery or do not allow continuous paper flow. (6-14-12 PC 2)

*Figure 604.11.7 – Children's dispenser outlet location*



Note: For adult dimensions see Fig. 604.7

*(a) Below grab bar*



(b) exception

**604.11.7.1 Location.** The outlet of toilet paper dispensers ~~primarily for children's use~~ shall be located within an area 24 inches (610 mm) minimum and 42 inches (1065 mm) maximum from the rear wall. The outlet of the dispenser shall be 14 inches (355 mm) minimum and 19 inches (485 mm) maximum above the floor. ~~There shall be a clearance of 1 1/2 inches (38 mm) minimum below the grab bar. (ed.)~~ (6-14-12 PC 2)

**EXCEPTION:** Toilet paper dispensers that accommodate a maximum of 2 toilet paper rolls of not more than 5 inch diameter each shall be permitted to be located 7 inches minimum and 9 inches maximum in front of the of the water closet measured to the centerline of the dispenser. The outlet of the dispenser shall be 14 inches (355 mm) minimum and 19 inches (485 mm) maximum above the floor. (6-11-12) (6-14-12 PC 2)

**604.11.8 Toilet Compartments.** ~~Wheelchair and ambulatory accessible~~ Toilet compartments ~~primarily for children's use~~ shall comply with Sections 604.9 and 604.10, as applicable. (ed.)

## 605 Urinals

**605.1 General.** ~~Accessible~~ urinals shall comply with Section 605. (ed.)

**605.2 Height and Depth.** Urinals shall be of the stall type or shall be of the wall hung type with the rim at 17 inches (430 mm) maximum above the floor. Urinals shall be 13 1/2 inches (345 mm) minimum in depth measured from the outer face of the urinal rim to the finished wall surface. (6-24-12)

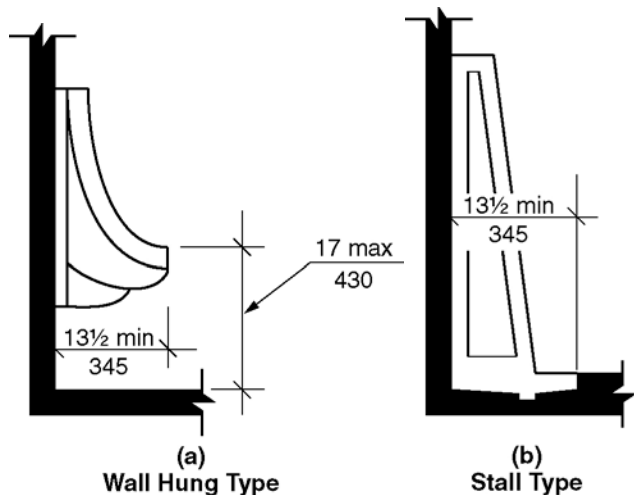


Figure 605.2 Height and depth of urinals (a & b)

**605.3 Clear Floor Space.** A clear floor space complying with Section 305, positioned for forward approach, shall be provided.

**605.4 Flush Controls.** Flush controls shall be hand operated or automatic. Hand operated flush controls shall comply with Section 309.

## 606 Lavatories and Sinks

**606.1 General.** Accessible lavatories and sinks shall comply with Section 606. (ed.)

**606.2 Clear Floor Space.** A clear floor space complying with Section 305.3, positioned for forward approach, shall be provided. Knee and toe clearance complying with Section 306 shall be provided. The dip of the overflow shall not be considered in determining knee and toe clearances.

### EXCEPTIONS:

1. A parallel approach complying with Section 305, shall be permitted to a kitchen sink in a space where a cook top or conventional range is not provided. (3-13-12 PC5)
2. The requirement for knee and toe clearance shall not apply to a lavatory in a toilet or bathing facility for a single occupant, accessed only through a private office and not for common use or public use.
3. A knee clearance of 24 inches (610 mm) minimum above the floor shall be permitted at lavatories and sinks used primarily by children ages 6 through 12 where the higher of the rim or counter surface is 31 inches (785 mm) maximum above the floor. (6-33-12)
4. A parallel approach complying with Section 305, shall be permitted at lavatories and sinks used primarily by children ages 5 and younger. (3-13-12 PC5)
5. The requirement for knee and toe clearance shall not apply to more than one bowl of a multibowl sink.
6. A parallel approach complying with Section 305, shall be permitted at wet bars. (3-13-12 PC5)

**606.3 Height.** The front of lavatories and sinks shall be 34 inches (865 mm) maximum above the floor, measured to the higher of the rim or counter surface.

**EXCEPTION:** A lavatory in a toilet or bathing facility for a single occupant, accessed only through a private office and not for common use or public use, shall not be required to comply with Section 606.3.

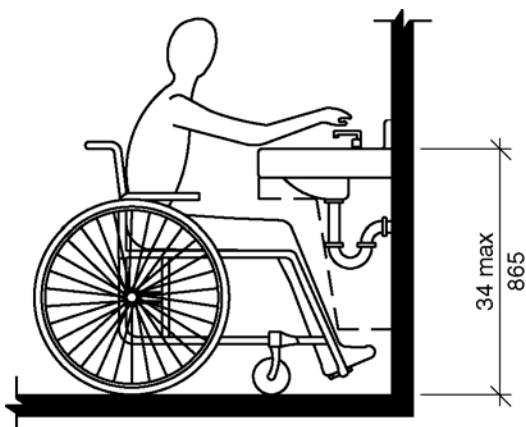


Figure 606.3 - Height of lavatories and sinks

**606.4 Faucets.** Faucets shall comply with Section 309. Hand-operated metering faucets shall remain open for 10 seconds minimum.

**EXCEPTION:** Automatic faucets shall not be required to comply with Section 309 provided that the reach depth to activate the faucets and the reach depth to the water flow is 11 inches maximum. (6-36-12) (ed.)

~~**606.5 Basin Location.** The interior edge of the rim of the lavatory basin shall be located 3 ½ inches (90 mm) maximum from the front edge of the fixture or countertop. (6-37-12 PC1.1 #24B)~~

**606.5 Lavatories with Enhanced Reach Range.** Where enhanced reach range is required at lavatories, faucets and soap dispenser controls shall have a reach depth of 11 inches (280 mm) maximum. Water and soap outlet shall be provided with a reach depth of 11 inches (280 mm) maximum. The lavatory shall be 34 inches maximum above the floor, measured to the higher of the rim or counter surface. (6-36-12)

**EXCEPTIONS:**

1. Enhanced reach range faucets shall not be required on lavatories provided with automatic faucets where the reach depth to activate the faucets and the reach depth to the water outlet is 11 inches (280 mm) maximum. (6-36-12) (ed.)
2. Enhanced reach range soap dispensers shall not be required on lavatories provided with automatic dispensers where the reach depth to activate the soap dispensers and the reach depth to the soap outlet is 11 inches (280 mm) maximum. (6-36-12) (ed.)

**606.6 Exposed Pipes and Surfaces.** Water supply and drainpipes under lavatories and sinks shall be insulated or otherwise configured to protect against contact. There shall be no sharp or abrasive surfaces under lavatories and sinks.

**607 Bathtubs**

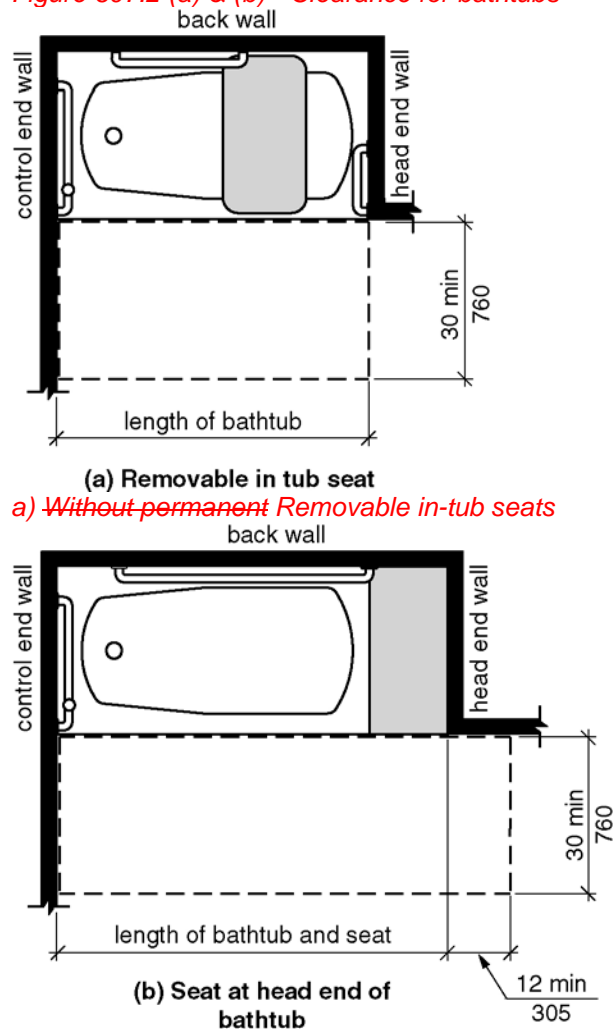
**607.1 General.** Accessible bathtubs shall comply with Section 607. (ed.)

**607.2 Clearance.** A clearance in front of bathtubs extending the length of the bathtub and 30 inches (760 mm) minimum in depth shall be provided. Where a permanent seat is provided at the head end of the bathtub, the clearance shall extend 12 inches (305 mm) minimum beyond the wall at the head end of the



bathtub.

Figure 607.2 (a) & (b) - Clearance for bathtubs



a) Without permanent Removable in-tub seats

b) With permanent seat at the head end of bathtub

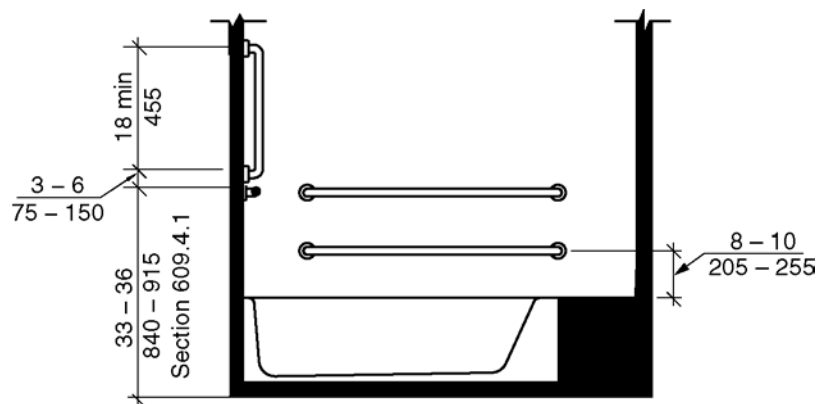
**607.3 Seat.** A permanent seat at the head end of the bathtub or a removable in-tub seat shall be provided. Seats shall comply with Section 610.

**607.4 Grab Bars.** Grab bars shall comply with Section 609 and shall be provided in accordance with Section 607.4.1 or 607.4.2.

**EXCEPTION:** Grab bars shall not be required to be installed in a bathing facility for a single occupant accessed only through a private office and not for common use or public use, provided reinforcement has been installed in walls and located so as to permit the installation of grab bars complying with Section 607.4.

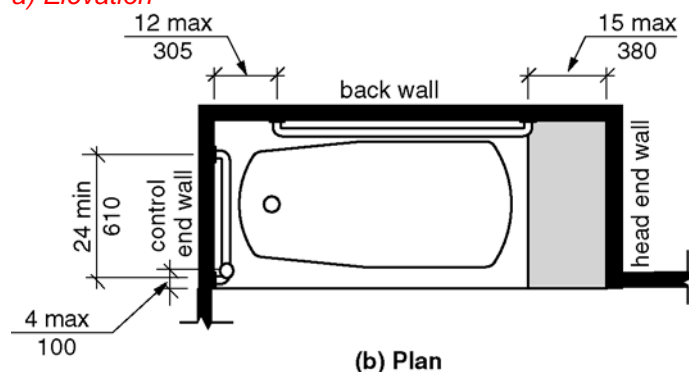
**607.4.1 Bathtubs with Permanent Seats.** For bathtubs with permanent seats, grab bars complying with Section 607.4.1 shall be provided. (ed.)

Figure 607.4.1 (a) and (b) Grab bars for bathtubs with permanent seats at head end of bathtub



(a) Elevation

a) Elevation



(b) Plan

b) Plan

**607.4.1.1 Back Wall.** Two horizontal grab bars shall be provided on the back wall, one complying with Section 609.4 and the other located 8 inches (205 mm) minimum and 10 inches (255 mm) maximum above the rim of the bathtub. Each grab bar shall be located 15 inches (380 mm) maximum from the head end wall and extend to 12 inches (305 mm) maximum from the control end wall.

**607.4.1.2 Control End Wall.** Control end wall grab bars shall comply with Section 607.4.1.2.

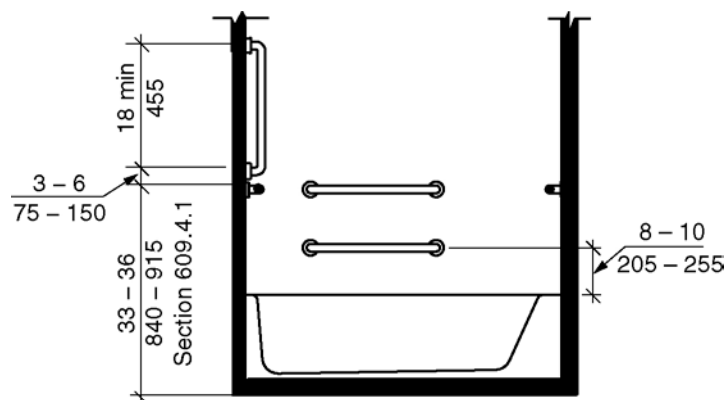
**EXCEPTION:** An L-shaped continuous grab bar of equivalent dimensions and positioning shall be permitted to serve the function of separate vertical and horizontal grab bars.

**607.4.1.2.1 Horizontal Grab Bar.** A horizontal grab bar 24 inches (610 mm) minimum in length shall be provided on the control end wall beginning near the front edge of the bathtub and extending toward the inside corner of the bathtub.

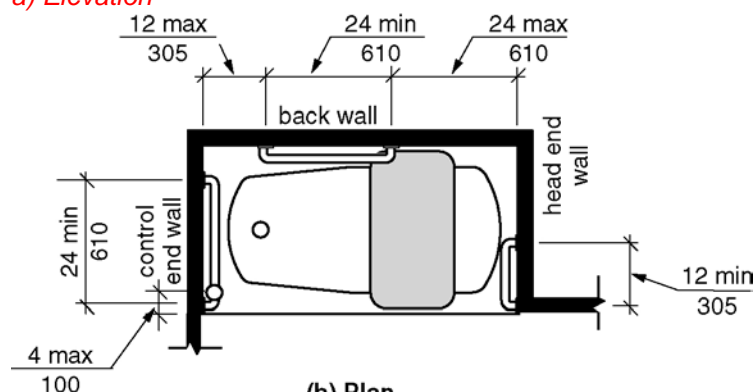
**607.4.1.2.2 Vertical Grab Bar.** A vertical grab bar 18 inches (455 mm) minimum in length shall be provided on the control end wall 3 inches (75 mm) minimum and 6 inches (150 mm) maximum above the horizontal grab bar, and 4 inches (100 mm) maximum inward from the front edge of the bathtub.

**607.4.2 Bathtubs with removable Seats.** For bathtubs with removable seats, grab bars complying with Section 607.4.2 shall be provided. (ed.)

*Figure 607.4.2(a) and (b) - Grab bars for bathtubs with removable seats*



(a) Elevation

*a) Elevation*

(b) Plan

*b) Plan*

**607.4.2.1 Back Wall.** Two horizontal grab bars shall be provided on the back wall, one complying with Section 609.4 and the other located 8 inches (205 mm) minimum and 10 inches (255 mm) maximum above the rim of the bathtub. Each grab bar shall be 24 inches (610 mm) minimum in length, located 24 inches (610 mm) maximum from the head end wall and extend to 12 inches (305 mm) maximum from the control end wall.

**607.4.2.2 Control End Wall.** Control end wall grab bars shall comply with Section 607.4.1.2.

**607.4.2.3 Head End Wall.** A horizontal grab bar 12 inches (305 mm) minimum in length shall be provided on the head end wall at the front edge of the bathtub.

**607.5 Controls.** Controls, other than drain stoppers, shall be provided on an end wall, located between the bathtub rim and grab bar, and between the open side of the bathtub and the centerline of the width of the bathtub. Controls shall comply with Section 309.4.

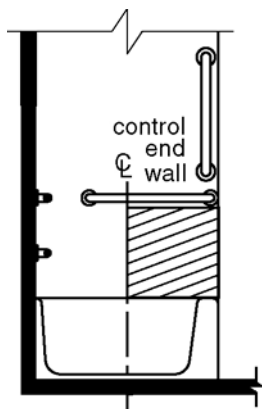


Figure 607.5 – Location of bathtub controls

**607.6 Hand Shower.** A hand shower with a hose 59 inches (1500 mm) minimum in length, that can be used as both a fixed shower head and as a hand shower, shall be provided. The hand shower shall have a control with a nonpositive shut-off feature. Where provided, an adjustable-height hand shower mounted on a vertical bar shall be installed so as to not obstruct the use of grab bars.

**607.7 Bathtub Enclosures.** Enclosures for bathtubs shall not obstruct controls, faucets, shower and spray units or obstruct transfer from wheelchairs onto bathtub seats or into bathtubs. Enclosures on bathtubs shall not have tracks installed on the rim of the bathtub.

**607.8 Water Temperature.** Bathtubs shall deliver water that is 120 degrees F (49 degrees C) maximum.

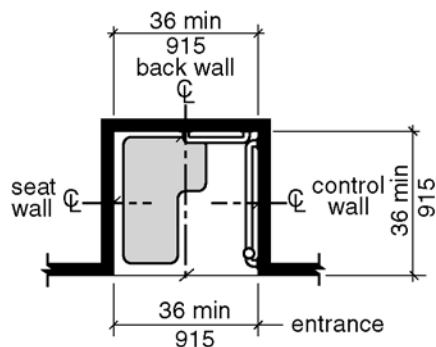
## 608 Shower Compartments

**608.1 General.** Accessible shower compartments shall comply with Section 608. (ed.)

**608.2 Size, Clearance and Seat.** Shower compartments shall have sizes, clearances and seats complying with Section 608.2.

**608.2.1 Transfer-Type Shower Compartments.** Transfer-type shower compartments shall comply with Section 608.2.1.

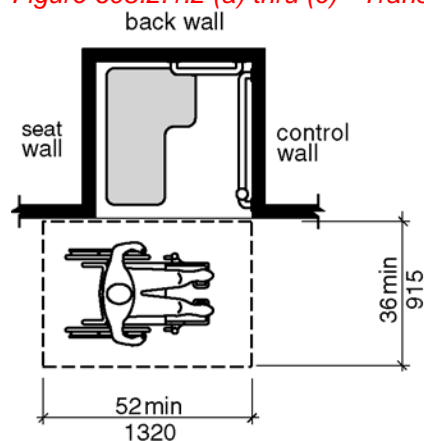
**608.2.1.1 Size.** Transfer-type shower compartments shall have a clear inside dimension of 36 inches (915 mm) in width and 36 inches (915 mm) in depth, measured at the center point of opposing sides. An entry 36 inches (915 mm) minimum in width shall be provided.



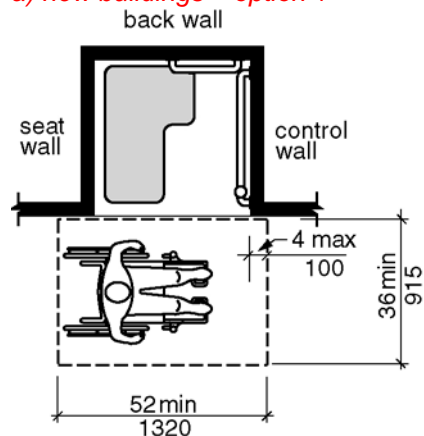
Note: inside finished dimensions measured at the center points of opposing sides

Figure 608.2.1.1 – Transfer type shower compartment size

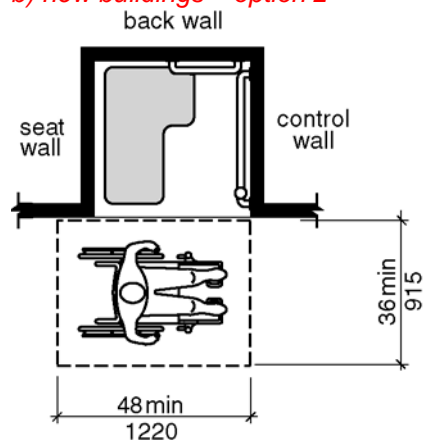
Figure 608.2.1.2 (a) thru (c) - Transfer type shower compartment clearances



a) new buildings – option 1



b) new buildings – option 2



c) existing buildings

#### 608.2.1.2 Clearance.

**608.2.1.2.1 New buildings .** In new buildings, a clearance of 52 inches (1320 mm) minimum in length, and 36 inches (915 mm) minimum in depth shall be provided adjacent to the open face of the compartment. The length of the clear floor space shall be measured perpendicular from either 1) the

~~control wall or 2) from 4 inches (100 mm) behind the control wall. The seat wall shall align with the wheelchair seat back in accordance with Section 305.8 or be 4 inches (100 mm) maximum behind the seat wall. (6-46-12 PC2.1) (6-46-12/2.1-PC2.1 Agenda #25.1)~~

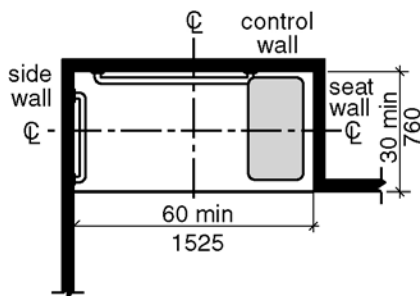
**608.2.1.2.2 Existing buildings and within new Type B units.** In existing buildings and within new Type B units, a clearance of 48 inches (1220 mm) minimum in length measured perpendicular from the control wall, and 36 inches (915 mm) minimum in depth shall be provided adjacent to the open face of the compartment. (3-6-12 PC2) (ed.)

**608.2.1.3 Seat.** A folding or non-folding seat complying with Section 610 shall be provided on the wall opposite the control wall.

**Exception:** A seat is not required to be installed in a shower for a single occupant, accessed only through a private office and not for common use or public use, provided reinforcement has been installed in walls and located so as to permit the installation of a shower seat.

**608.2.2 Standard Roll-in-Type Shower Compartments.** Standard roll-in-type shower compartments shall comply with Section 608.2.2.

**608.2.2.1 Size.** Standard roll-in-type shower compartments shall have a clear inside dimension of 60 inches (1525 mm) minimum in width and 30 inches (760 mm) minimum in depth, measured at the center point of opposing sides. An entry 60 inches (1525 mm) minimum in width shall be provided.

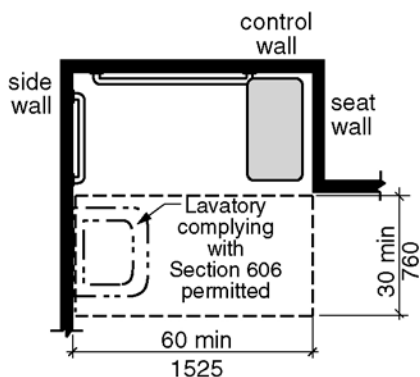


Note: inside finished dimensions measured at the center points of opposing sides

*Figure 608.2.2.1 - Standard roll-in-type shower compartment size*

**608.2.2.2 Clearance.** A clearance of 60 inches (1525 mm) minimum in length adjacent to the 60-inch (1525 mm) width of the open face of the shower compartment, and 30 inches (760 mm) minimum in depth, shall be provided.

**EXCEPTION:** A lavatory complying with Section 606 shall be permitted at the end of the clearance opposite the seat.



Note: inside finished dimensions measured at the center points of opposing sides

*Figure 608.2.2.2 - Standard roll-in-type shower compartment clearance*

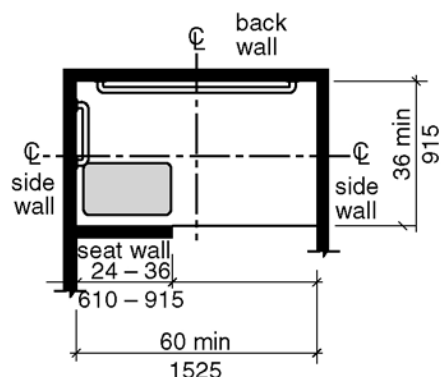
**608.2.2.3 Seat.** A folding seat complying with Section 610 shall be provided on an end wall.

**EXCEPTIONS:**

1. A seat is not required to be installed in a shower for a single occupant accessed only through a private office and not for common use or public use, provided reinforcement has been installed in walls and located so as to permit the installation of a shower seat.
2. A fixed seat shall be permitted where the seat does not overlap the minimum clear inside dimension required by Section 608.2.2.1.

**608.2.3 Alternate Roll-in-Type Shower Compartments.** Alternate roll-in-type shower compartments shall comply with Section 608.2.3.

**608.2.3.1 Size.** Alternate roll-in shower compartments shall have a clear inside dimension of 60 inches (1525 mm) minimum in width, and 36 inches (915 mm) in depth, measured at the center point of opposing sides. An entry 36 inches (915 mm) minimum in width shall be provided at one end of the 60-inch (1525 mm) width of the compartment. A seat wall, 24 inches (610 mm) minimum and 36 inches (915 mm) maximum in length, shall be provided on the entry side of the compartment.



Note: inside finished dimensions measured at the center points of opposing sides

*Figure 608.2.3.1 Alternate roll-in shower compartment size*

**608.2.3.2 Seat.** A folding seat complying with Section 610 shall be provided on the seat wall opposite the back wall.

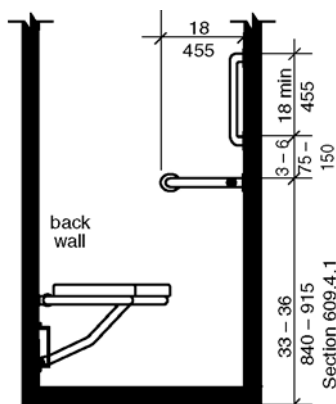
**EXCEPTION:** A seat is not required to be installed in a shower for a single occupant, accessed only through a private office and not for common use or public use, provided reinforcement has been installed in walls and located so as to permit the installation of a shower seat.

**608.3 Grab Bars.** Grab bars shall comply with Section 609 and shall be provided in accordance with Section 608.3. Where multiple grab bars are used, required horizontal grab bars shall be installed at the same height above the floor.

**EXCEPTION:** Grab bars shall not be required to be installed in a shower for a single occupant, accessed only through a private office and not for common use or public use, provided reinforcement has been installed in walls and located so as to permit the installation of grab bars complying with Section 608.3. (ed.)

**608.3.1 Transfer-Type Showers.** Grab bars for transfer type showers shall comply with Section 608.3.1.

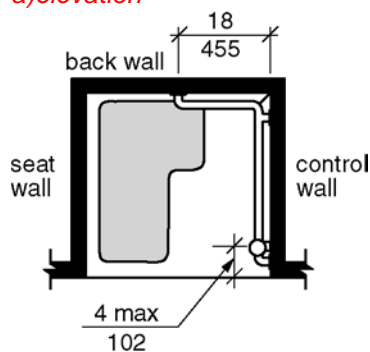
*Figure 608.3.1 – Grab bars in transfer-type shower*



(a)

Grab bars in transfer-type showers  
Elevation

*a) elevation*



*b) plan*

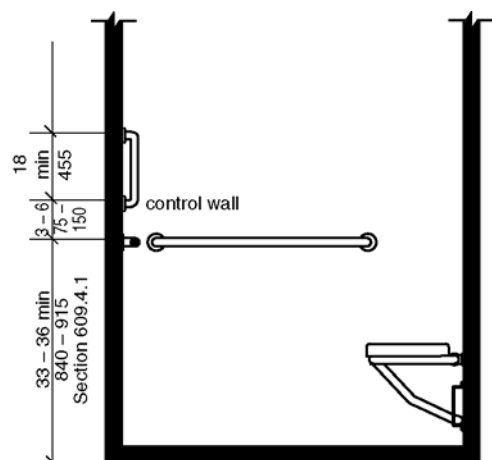
**608.3.1.1 Horizontal Grab Bars.** Horizontal grab bars shall be provided across the control wall and on the back wall to a point 18 inches (455 mm) from the control wall.

**608.3.1.2 Vertical Grab Bar.** A vertical grab bar 18 inches (455 mm) minimum in length shall be provided on the control end wall 3 inches (75 mm) minimum and 6 inches (150 mm) maximum above the horizontal grab bar, and 4 inches (100 mm) maximum inward from the front edge of the shower.

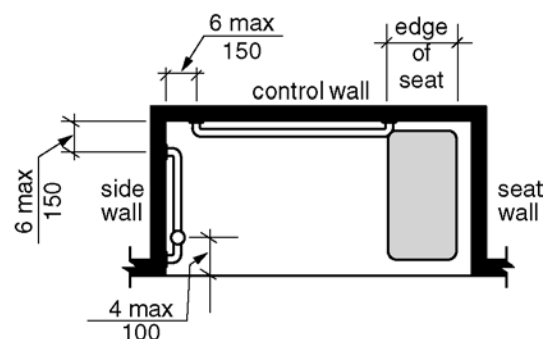


**608.3.2 Standard Roll-in-Type Showers.** Grab bars in standard roll-in showers shall comply with Sections 608.3.2.1 through 608.3.2.3. (6-55-12 PC1)

*Figure 608.3.2 – Grab bars in standard roll-in-type shower*



*a)elevation*



*b)plan*

**608.3.2.1 Back wall grab bar.** In standard roll-in type showers, a grab bar shall be provided on the back wall beginning at the edge of the seat. The grab bars shall not be provided above the seat. The back wall grab bar shall extend the length of the wall and extend within 6 inches (150 mm) maximum from the adjacent side wall opposite the seat.

**Exceptions:**

1. The back wall grab bar but shall not be required to exceed 48 inches (1220 mm) in length.
2. The back wall grab bar is not required to extend within 6 inches (150 mm) of the adjacent side wall opposite the seat if it would require the grab bar length to exceed 48 inches (1220 mm) in length. (6-55-12/3.1-PC3.2 – Agenda item #28.2)

**608.3.2.1 Back wall grab bar.** In standard roll-in type showers, a grab bar shall be provided on the back wall beginning at the edge of the seat. The grab bars shall not be provided above the seat. The back wall grab bar shall extend the length of the wall and extend within 6 inches (150 mm) maximum from the adjacent side wall opposite the seat.

**Exceptions:**

1. The back wall grab bar but shall not be required to exceed 48 inches (1220 mm) in length.

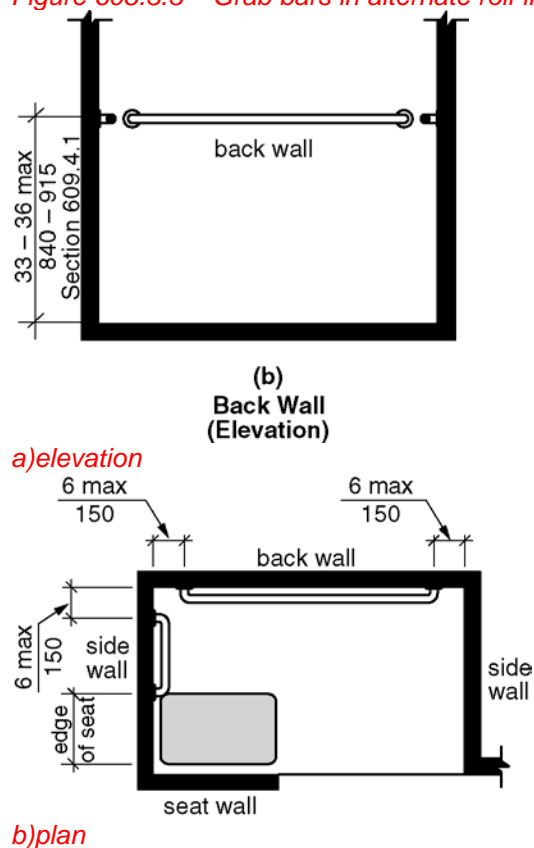
**608.3.2.2 Side wall grab bars.** Where a side wall is provided opposite the seat within 72 inches (1830 mm) of the seat wall, a grab bar shall be provided on the side wall opposite the seat. The side wall grab bar shall extend the length of the wall and extend within 6 inches (150 mm) maximum from the adjacent back wall. (6-55-12 PC1)

**Exception:** The side wall grab bar shall not be required to exceed 30 inches (760 mm) in length. (6-55-12 PC1)

**608.3.2.3 Vertical Grab Bar.** Where a side wall is provided opposite the seat within 72 inches (1830 mm) of the seat wall a vertical grab bar shall be provided. A vertical grab bar 18 inches (450 mm) minimum in length shall be provided on the end wall 3 inches (75 mm) minimum and 6 inches (150 mm) maximum above the horizontal grab bar, and 4 inches (100 mm) maximum inward from the front edge of the shower. (6-61-12 PC1.2)

**608.3.3 Alternate Roll-in-Type Showers.** In alternate roll-in type showers, grab bars shall be provided on the back wall and the side wall adjacent to the seat. Grab bars shall not be provided above the seat. Grab bars shall be 6 inches (150 mm) maximum from the adjacent wall. (ed.)

Figure 608.3.3 – Grab bars in alternate roll-in-type shower

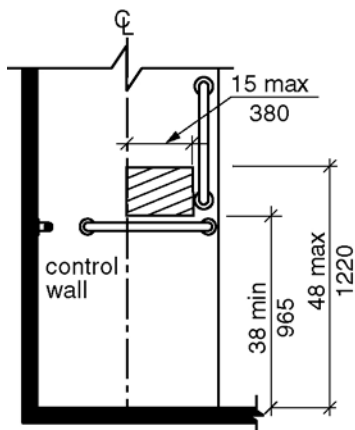


**608.4 Controls and Hand Showers.** Controls and hand showers shall comply with Sections 608.4 and 309.4.

**608.4.1 Transfer-Type Showers.** In transfer-type showers, the controls and hand shower shall be located:

1. On the control wall opposite the seat.

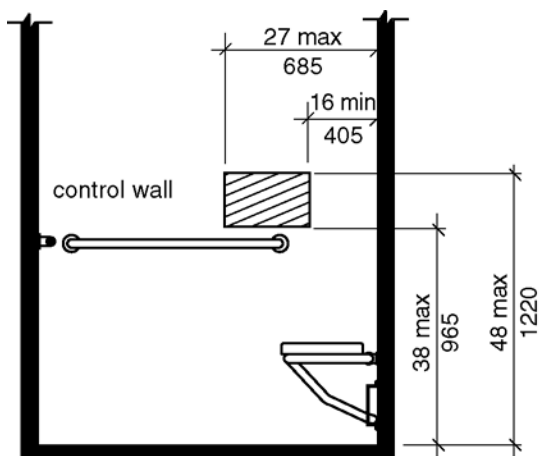
2. At a height of 38 inches (965 mm) minimum and 48 inches (1220 mm) maximum above the shower floor, and
3. 15 inches (380 mm) maximum, from the centerline of the control wall toward the shower opening.



*Figure 608.4.1 - Transfer type shower controls and handshower location*

**608.4.2 Standard Roll-in Showers.** In standard roll-in showers, the controls and hand shower shall not be located above the seat. Controls and hand showers shall be located according to the following: (6-61-12) (6-61-12 PC1.2)

1. On the back wall,
2. At a height 38 inches (965 mm) minimum and 48 inches (1220 mm) maximum above the shower floor, and
3. 16 inches (405 mm) minimum and 27 inches (685 mm) maximum from the wall behind the seat.



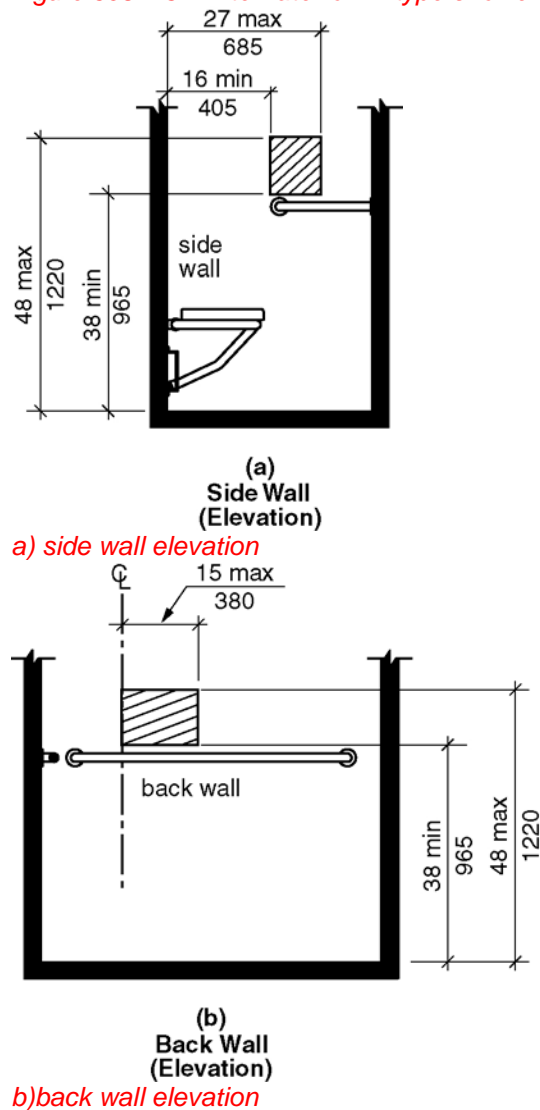
*Figure 608.4.2 – Standard roll-in-type shower controls and handshower location*

**608.4.3 Alternate Roll-in Showers.** In alternate roll-in showers, the controls and hand shower shall be located:

1. At a height of 38 inches (965 mm) minimum and 48 inches (1220 mm) maximum above the shower floor-, and
2. Where the controls and hand shower are located on the end wall adjacent to the seat, the controls and hand shower shall be 16 inches (405 mm) minimum and 27 inches (685 mm) maximum from the wall behind the seat wall-, or

3. Where the controls and hand shower are located on the back wall opposite the seat, the controls and hand shower shall be located within 15 inches (380 mm) maximum from, ~~left or right,~~ of the centerline of the seat toward the transfer space. (6-60-12)(6-62-12) (ed.)

*Figure 608.4.3 – Alternate roll-in-type shower controls and handshower location*



**608.5 Hand Showers.** A hand shower with a hose 59 inches long (1500 mm) minimum in length, that can be used both as a fixed shower head and as a hand shower, shall be provided. The hand shower shall have a control with a nonpositive shut-off feature. Where provided, an adjustable-height hand shower mounted on a vertical bar shall be installed so as to not obstruct the use of grab bars. A means to hold the hand shower wand while in the on or off position shall be located at a height of 38 inches minimum and 48 inches maximum above the shower finish floor. (6-65-12)

**EXCEPTION:** In other than Accessible units and Type A units, a fixed shower head located 48 inches (1220 mm) maximum above the shower floor shall be permitted in lieu of a hand shower.

**608.6 Thresholds.** Thresholds in roll-in-type shower compartments shall be  $\frac{1}{2}$  inch (13 mm) maximum in height in accordance with Section 303. In transfer-type shower compartments, thresholds  $\frac{1}{2}$  inch (13 mm) maximum in height shall be beveled, rounded, or vertical.

**EXCEPTION:** In existing facilities, in transfer-type shower compartments where provision of a threshold  $1\frac{1}{2}$  inch (13 mm) in height would disturb the structural reinforcement of the floor slab, a threshold 2 inches (51 mm) maximum in height shall be permitted.

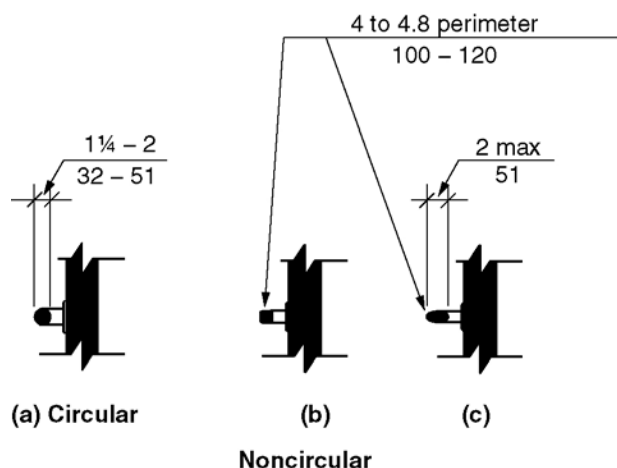
**608.7 Shower Enclosures.** Shower compartment enclosures for shower compartments shall not obstruct controls or obstruct transfer from wheelchairs onto shower seats.

**608.8 Water Temperature.** Showers shall deliver water that is 120 degrees F (49 degrees C) maximum.

## 609 Grab Bars

**609.1 General.** Grab bars in **accessible** toilet or bathing facilities shall comply with Section 609. (ed.)

**609.2 Cross Section.** Grab bars shall have a cross section complying with Section 609.2.1 or 609.2.2.



*Figure 609.2 - Size of grab bars*

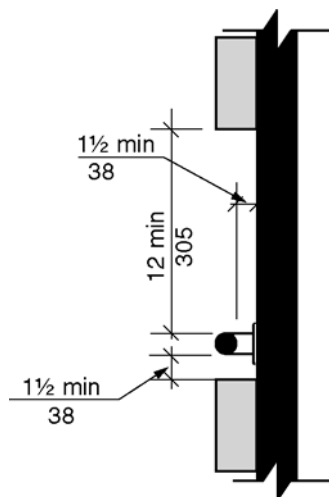
**609.2.1 Circular Cross Section.** Grab bars with a circular cross section shall have an outside diameter of  $1\frac{1}{4}$  inch (32 mm) minimum and 2 inches (51 mm) maximum.

**609.2.2 Noncircular Cross Section.** Grab bars with a noncircular cross section shall have a cross section dimension of 2 inches (51 mm) maximum, and a perimeter dimension of 4 inches (100 mm) minimum and 4.8 inches (122 mm) maximum.

**609.3 Spacing.** The space between the wall and the grab bar shall be  $1\frac{1}{2}$  inches (38 mm). The space between the grab bar and projecting objects below and at the ends of the grab bar shall be  $1\frac{1}{2}$  inches (38 mm) minimum. The space between the grab bar and projecting objects above the grab bar shall be 12 inches (305 mm) minimum.

### EXCEPTIONS:

1. The space between the grab bars and shower controls, shower fittings, and other grab bars above the grab bar shall be permitted to be  $1\frac{1}{2}$  inches (38 mm) minimum.
2. Recessed dispensers projecting from the wall  $\frac{1}{4}$  inch (6.3 mm) maximum measured from the face of the dispenser and complying with Section 604.7 shall be permitted within the 12-inch (305 mm) space above and the  $1\frac{1}{2}$  inch (38 mm) spaces below and at the ends of the grab bar.



*Figure 609.3 – Spacing of grab bars*

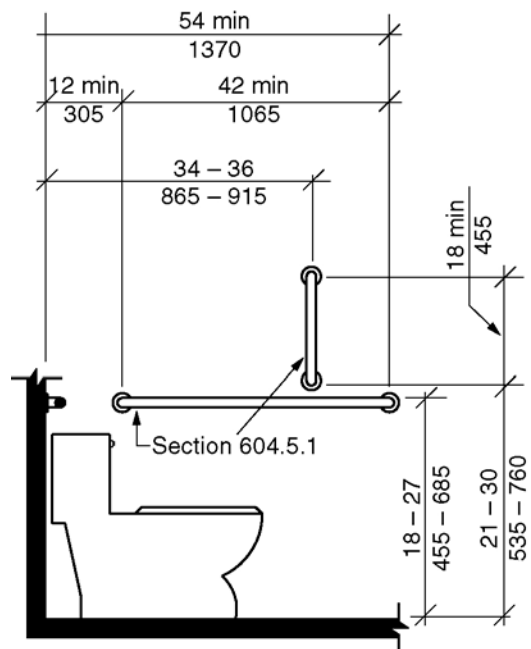
#### **609.4 Position of Grab Bars.**

**609.4.1 General.** Grab bars shall be installed in a horizontal position, 33 inches (840 mm) minimum and 36 inches (915 mm) maximum above the floor measured to the top of the gripping surface or shall be installed as required by Items 1 through 3.

1. The lower grab bar on the back wall of a bathtub shall comply with Section 607.4.1.1 or 607.4.2.1.
2. Vertical grab bars shall comply with Sections 604.5.1, 607.4.1.2.2, 607.4.2.2, and 608.3.1.2.
3. Grab bars at water closets primarily for children's use shall comply with Section 609.4.2

**609.4.2 Position of Children's Grab Bars.** At water closets primarily for children's use complying with Section 604.11, grab bars shall be installed in a horizontal position 18 inches (455 mm) minimum and 27 inches (685 mm) maximum above the floor measured to the top of the gripping surface. A vertical grab bar shall be mounted with the bottom of the bar located between 21 inches (533 mm) minimum and 30 inches (760 mm) maximum above the floor and with the centerline of the bar located between 34 inches (865 mm) minimum and 36 inches (915 mm) maximum from the rear wall.

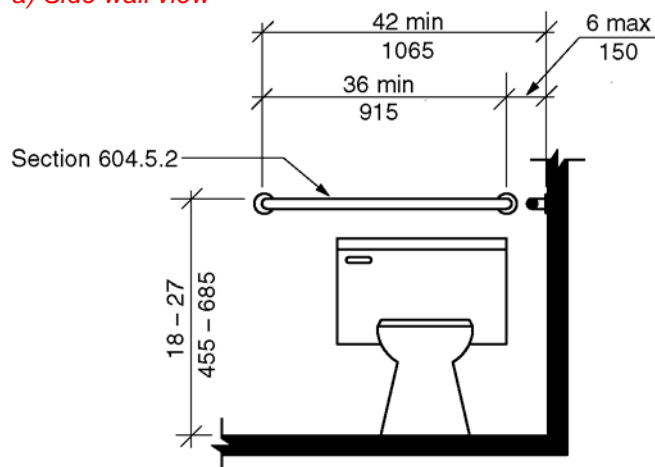
*Figure 609.4.2 – Positions of children's grab bars*



Note: For adult dimensions see Fig. 604.5.1

(a) Side Wall View

a) Side wall view



Note: For adult dimensions see Fig. 604.5.2

(b) Rear Wall View

b) Rear wall view

**609.5 Surface Hazards.** Grab bars, and any wall or other surfaces adjacent to grab bars, shall be free of sharp or abrasive elements. Edges shall be rounded.

**609.6 Fittings.** Grab bars shall not rotate within their fittings.

**609.7 Installation and Configuration.** Grab bars shall be installed in any manner that provides a gripping surface at the locations specified in this standard and does not obstruct the clear floor space. Horizontal and vertical grab bars shall be permitted to be separate bars, a single piece bar, or combination thereof.

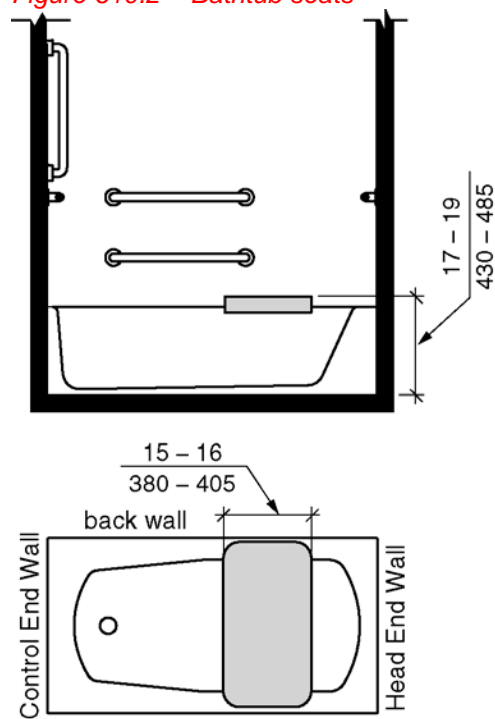
**609.8 Structural Strength.** Allowable stresses shall not be exceeded for materials used where a vertical or horizontal force of 250 pounds (1112 N) is applied at any point on the grab bar, fastener mounting device, or supporting structure.

## 610 Seats

**610.1 General.** Seats in **accessible** bathtubs and shower compartments shall comply with Section 610. (ed.)

**610.2 Bathtub Seats.** The height of bathtub seats shall be 17 inches (430 mm) minimum and 19 inches (485 mm) maximum above the bathroom floor, measured to the top of the seat. Removable in-tub seats shall be 15 inches (380 mm) minimum and 16 inches (405 mm) maximum in depth. Removable in-tub seats shall be capable of secure placement. Permanent seats shall be 15 inches (380 mm) minimum in depth and shall extend from the back wall to or beyond the outer edge of the bathtub. Permanent seats shall be positioned at the head end of the bathtub.

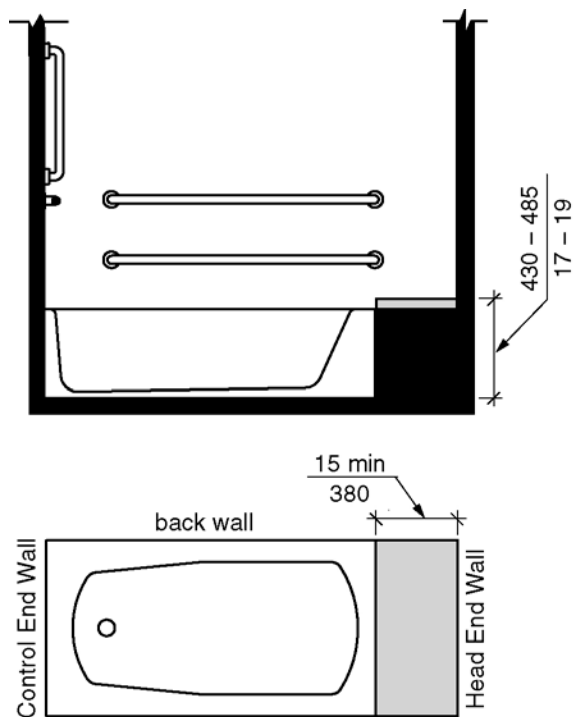
*Figure 610.2 – Bathtub seats*



**(a) Removable in-Tub Seat**

*a) Removable in-tub seats*



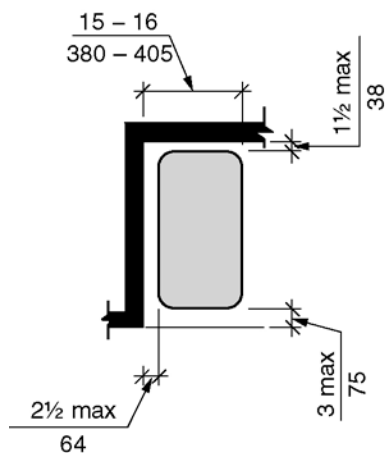


(b) Seat provided at head end of tub

**b) Permanent Seats provided at the head end of the bathtub**

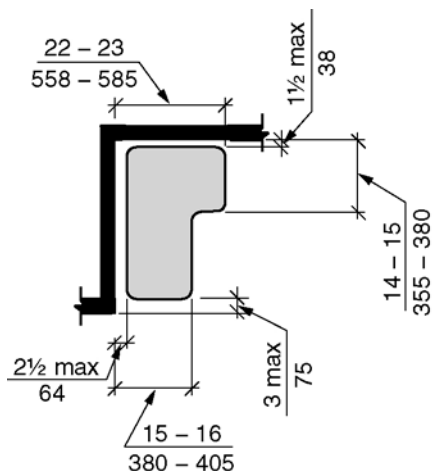
**610.3 Shower Compartment Seats.** The height of shower compartment seats shall be 17 inches (430 mm) minimum and 19 inches (485 mm) maximum above the bathroom floor, measured to the top of the seat. In transfer-type and alternate roll-in-type showers, the seat shall extend along the seat wall to a point within 3 inches (75 mm) of the compartment entry. In standard roll-in-type showers, the seat shall extend from the control wall to a point within 3 inches (75 mm) of the compartment entry. Seats shall comply with Section 610.3.1 or 610.3.2.

**610.3.1 Rectangular Seats.** The rear edge of a rectangular seat shall be  $2\frac{1}{2}$  inches (64 mm) maximum and the front edge 15 inches (380 mm) minimum and 16 inches (405 mm) maximum from the seat wall. The side edge of the seat shall be  $1\frac{1}{2}$  inches (38 mm) maximum from the back wall of a transfer-type shower and  $1\frac{1}{2}$  inches (38 mm) maximum from the control wall of a roll-in-type shower.



**Figure 610.3.1 – Rectangular shower compartment seats**

**610.3.2 L-Shaped Seats.** The rear edge of an L-shaped seat shall be  $2\frac{1}{2}$  inches (64 mm) maximum and the front edge 15 inches (380 mm) minimum and 16 inches (405 mm) maximum from the seat wall. The rear edge of the “L” portion of the seat shall be 1 1/2 inches (38 mm) maximum from the wall and the front edge shall be 14 inches (355 mm) minimum and 15 inches (380 mm) maximum from the wall. The end of the “L” shall be 22 inches (560 mm) minimum and 23 inches (585 mm) maximum from the main seat wall.



*Figure 610.3.2 – L-shaped shower compartment seats*

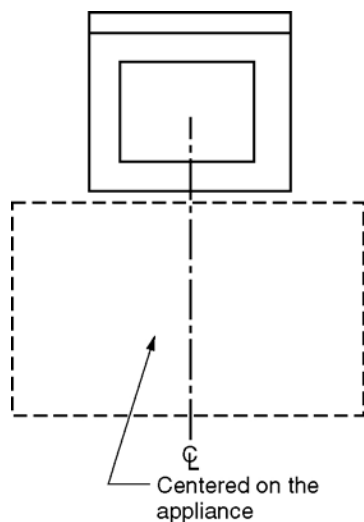
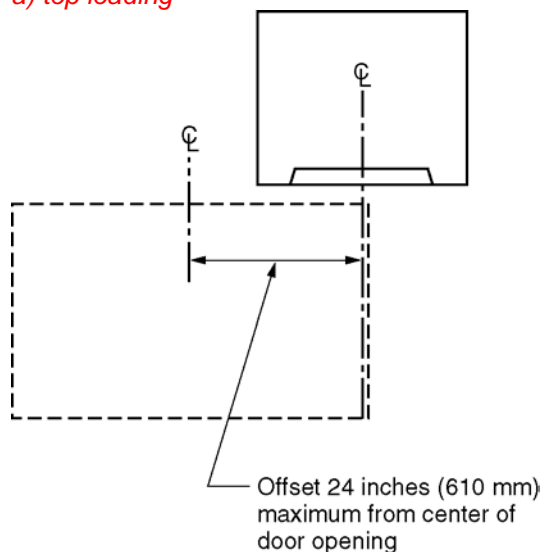
**610.4 Structural Strength.** Allowable stresses shall not be exceeded for materials used where a vertical or horizontal force of 250 pounds (1112 N) is applied at any point on the seat, fastener mounting device, or supporting structure.

## 611 Washing Machines and Clothes Dryers

**611.1 General.** ~~Accessible~~ washing machines and clothes dryers shall comply with Section 611. (ed.)

**611.2 Clear Floor Space.** A clear floor space complying with Section 305, positioned for parallel approach, shall be provided. For top loading machines, the clear floor space shall be centered on the appliance. For front loading machines, the centerline of the clear floor space shall be offset 24 inches (610 mm) maximum from the centerline of the door opening.

*Figure 611.2 - Clear floor space*

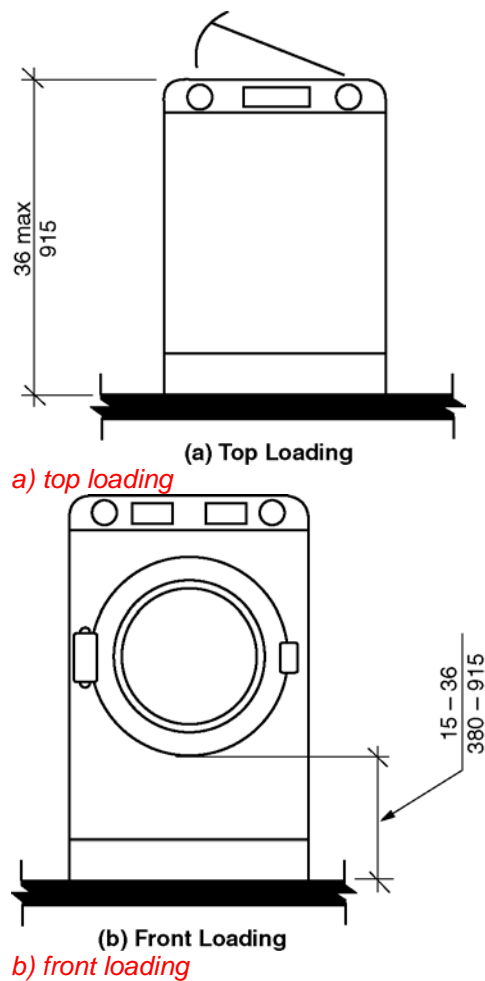
**(a) Top Loading***a) top loading***(b) Front Loading***b) front loading*

**611.3 Operable Parts.** Operable parts, including doors, lint screens, detergent and bleach compartments, shall comply with Sections 308 and 309.

**EXCEPTION:** The height of the obstruction in Section 308.3.2 shall be permitted to be 36 inches (915 mm) maximum above the floor. (6-69-12)

**611.4 Height.** Top loading machines shall have the door to the laundry compartment 36 inches (915 mm) maximum above the floor. Front loading machines shall have the bottom of the opening to the laundry compartment 15 inches (380 mm) minimum and 36 inches (915 mm) maximum above the floor.

*Figure 611.4- Height of the laundry equipment*



## 612 Saunas and Steam Rooms

**612.1 General.** Saunas and steam rooms shall comply with Section 612.

**612.2 Bench.** Where seating is provided in saunas and steam rooms, at least one bench shall comply with Section 903. Doors shall not swing into the clear floor space required by Section 903.2.

**EXCEPTION:** Where the room is for individual use and a clear floor space complying with Section 305.3 is provided within the room beyond the arc of the door swing, the door shall not be required to comply with ~~Section 612.2~~ this section. (6-70-12) (ed.)

**612.3 Turning space.** A turning space complying with Section 304 shall be provided within saunas and steam rooms.

## Chapter 7. Communication Elements and Features

### 701 General

**701.1 Scope.** Communications elements and features required to be accessible by the scoping provisions adopted by the administrative authority shall comply with the applicable provisions of Chapter 7.

~~701.1.2 Light Reflectance Value.~~ The light reflectance value (LRV) of surfaces shall be determined in accordance with BS 8493 for the following surface types:

- ~~1. Opaque paint coatings and paint systems, including those that cause extreme angular dependences of reflected light and those that have a surface texture of less than 2 mm.~~
- ~~2. Opaque coverings including those that cause extreme angular dependences of reflected light, and those that have an unyielding texture of less than 2 mm.~~
- ~~3. Opaque coverings with a yielding pile, e.g. carpet.~~
- ~~4. Opaque materials, including those that cause extreme angular dependences of reflected light, and those that have a texture of less than 2 mm, e.g. finished metals.~~
- ~~5. Opaque materials coated with non-opaque coatings or coverings, e.g. timber door coated with a woodstain, including those that cause extreme angular dependences of reflected light, and those that have a texture of less than 2 mm.~~
- ~~6. Multi-colored surfaces.~~
- ~~7. Ordinary materials as defined in Section 3. Terms and Definitions, subsection 3.3 in BS 8493 listed in Section 106.2.3. (7-1-12/3.1 – PC3.3 Agenda Item #35.3 )~~

~~701.1.2.1 Other Surfaces.~~ Other surfaces shall comply with Section 703.1.3.1. (7-1-12/3.1 – PC3.3 Agenda Item #35.3 )

~~701.1.3 Contrast Value.~~ The contrast between the LRVs of adjacent surfaces required by Sections 703.2.1.2, 703.5.3.2, 703.6.3.2 and 705.3 shall be determined by Equation 7-1,

~~Contrast = [(B1-B2)/B1] x 100 percent ————— Equation 7-1~~

~~Where~~

- ~~B1 = light reflectance value (LRV) of the lighter surface,~~
- ~~B2 = light reflectance value (LRV) of the darker surface. (7-1-12/3.1 – PC3.3 Agenda Item #35.3 )~~

~~701.1.3.1 Other Surfaces.~~ Surfaces not within the scope of BS 8493 shall provide contrast between adjacent surfaces that are either light on dark or dark on light. (7-1-12/3.1 – PC3.3 Agenda Item #35.3 )

### 702 Alarms

**702.1 General.** Accessible audible and visible alarms and notification appliances that are part of a building fire alarm system shall be installed in accordance with NFPA 72 listed in Section 106.2.5, be powered by a commercial light and power source, be permanently connected to the wiring of the premises electric system, and be permanently installed. (7-2-12) (ed.)

**EXCEPTION:** Audible and visible notification appliances provided within dwelling or sleeping units shall comply with Section 1106.2 through 1106.4.4. (7-2-12)

## 703 Signs

**703.1 General.** Accessible signs shall comply with Section 703. Tactile signs shall contain both raised characters and braille. Where signs with both visual and raised characters are required, either one sign with both visual and raised characters, or two separate signs, one with visual, and one with raised characters, shall be provided. (ed.)

**703.1.1 Designations.** Interior and exterior signs identifying permanent rooms and spaces shall comply with Sections 703.1, 703.2, and 703.3.

**EXCEPTION:** Exterior signs that are not located at the door to the space they serve shall not be required to comply with Section 703.3.

**703.1.2 Directional and Informational Signs.** Signs that provide direction to or information about interior spaces and facilities of the site shall comply with Section 703.2.

**703.1.3 Pictograms.** Where pictograms are provided as designations of permanent interior rooms and spaces, the pictograms shall comply with Section 703.5 and shall have text descriptors located directly below the pictogram field and complying with Sections 703.2 and 703.3.

**EXCEPTION:** Pictograms that provide information about a room or space, such as “no smoking”, occupant logos, and the International Symbol of Accessibility, shall not be required to have text descriptors.

## 703.2 Visual Characters.

**703.2.1 General.** Visual characters shall comply with the following:

1. Visual characters that also serve as raised characters shall comply with Section 703.3, or
2. Visual characters on VMS signage shall comply with Section 703.7, or
3. Visual characters not covered in items 1 and 2 shall comply with Section 703.2.

**EXCEPTION:** The visual and raised requirements of item 1 shall be permitted to be provided by two separate signs that provide corresponding information provided one sign complies with Section 703.2 and the second sign complies with Section 703.3.

**703.2.1.1 Nonglare Finish.** The glare from coverings, the finish of characters and their background shall not exceed 19 gloss units (gu) as measured on a 60-degree gloss meter. (7-1-12)

~~**703.2.1.2 Contrast.** The Light Reflectance Value (LRV) of characters and their background shall contrast 70 percent minimum as determined in accordance with Equation 7-1. The lighter surface shall have a LRV of not less than 45. (7-1-12/3.1 – PC3.3 Agenda Item #35.3)~~

**703.2.2 Case.** Characters shall be uppercase, lowercase, or a combination of both.

**703.2.3 Style.** Characters shall be conventional in form. Characters shall not be italic, oblique, script, highly decorative, or of other unusual forms.

**703.2.4 Character Height.** The uppercase letter “I” shall be used to determine the allowable height of all characters of a font. The uppercase letter “I” of the font shall have a minimum height complying with

Table 703.2.4. Viewing distance shall be measured as the horizontal distance between the character and an obstruction preventing further approach towards the sign.

**EXCEPTION:** In assembly seating where the maximum viewing distance is 100 feet (30.5 m) or greater, the height of the uppercase “I” of fonts shall be permitted to be 1 inch (25.4 mm) for every 30 feet (9.1 m) of viewing distance, provided the character height is 8 inches (205 mm) minimum. Viewing distance shall be measured as the horizontal distance between the character and where someone is expected to view the sign.

**Table 703.2.4—Visual Character Height**

Height above Floor to Baseline of Character <sup>1</sup>	Horizontal Viewing Distance <sup>2</sup>	Minimum Character Height
40 inches (1015 mm) to less than or equal to 70 inches (1780 mm)	Less than 6 feet (1830 mm)	<sup>5</sup> / <sub>8</sub> inch (16 mm)
	6 feet (1830 mm) and greater	<sup>5</sup> / <sub>8</sub> inch (16 mm), plus <sup>1</sup> / <sub>8</sub> inch (3.2 mm) per foot (305 mm) of viewing distance above 6 feet (1830 mm)
Greater than 70 inches (1780 mm) to less than or equal to 120 inches (3050 mm)	Less than 15 feet (4570 mm)	2 inches (51 mm)
	15 feet (4570 mm) and greater	2 inches (51 mm), plus <sup>1</sup> / <sub>8</sub> inch (3.2 mm) per foot (305 mm) of viewing distance above 15 feet (4570 mm)
Greater than 120 inches (3050 mm)	Less than 21 feet (6400 mm)	3 inches (75 mm)
	21 feet (6400 mm) and greater	3 inches (76 mm), plus <sup>1</sup> / <sub>8</sub> inch (3.2 mm) per foot (305 mm) of viewing distance above 21 feet (6400 mm)

1. The vertical height is measured from the floor of the viewing position to the baseline of the highest line of characters.
2. ~~The horizontal viewing distance shall be measured as the horizontal distance between the character and an obstruction preventing further approach towards the sign or where applicable, as stated in the exception to Section 703.2.4. (7-6-12) (ed.)~~

**703.2.5 Character Width.** The uppercase letter “O” shall be used to determine the allowable width of all characters of a font. The width of the uppercase letter “O” of the font shall be 55 percent minimum and 110 percent maximum of the height of the uppercase “I” of the font.

**703.2.6 Stroke Width.** The uppercase letter “I” shall be used to determine the allowable stroke width of all characters of a font. The stroke width shall be 10 percent minimum and 30 percent maximum of the height of the uppercase “I” of the font.

**703.2.7 Character Spacing.** Spacing shall be measured between the two closest points of adjacent characters within a message, excluding word spaces. Spacing between individual characters shall be 10 percent minimum and 35 percent maximum of the character height.

**703.2.8 Line Spacing.** Spacing between the baselines of separate lines of characters within a message shall be 135 percent minimum and 170 percent maximum of the character height.

**EXCEPTION:** In assembly seating where the maximum viewing distance is 100 feet (30.5 m) or greater, the spacing between the baselines of separate lines of characters within a message shall be permitted to be 120 percent minimum and 170 percent maximum of the character height.

**703.2.9 Height Above Floor.** Visual characters shall be 40 inches (1015 mm) minimum above the floor of the viewing position, measured to the baseline of the character. Heights shall comply with Table 703.2.4, based on the size of the characters on the sign.

**EXCEPTION:** Visual characters indicating elevator car controls shall not be required to comply with Section 703.2.9.

**703.2.10 Contrast.** Characters and their background shall have a non-glare finish. Characters shall contrast with their background, with either light characters on a dark background or dark characters on a light background. (7-1-12/3.1-PC 3.3)

### 703.3 Raised Characters.

**703.3.1 General.** Raised characters shall comply with Section 703.3, and shall be duplicated in braille complying with Section 703.4.

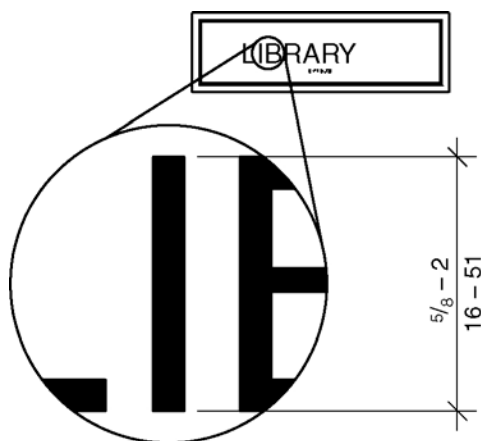
**703.3.2 Depth.** Raised characters shall be raised  $\frac{1}{32}$  inch (0.8 mm) minimum above their background.

**703.3.3 Case.** Characters shall be uppercase.

**703.3.4 Style.** Characters shall be sans serif. Characters shall not be italic, oblique, script, highly decorative, or of other unusual forms.

**703.3.5 Character Height.** The uppercase letter “I” shall be used to determine the allowable height of all characters of a font. The height of the uppercase letter “I” of the font, measured vertically from the baseline of the character, shall be  $\frac{5}{8}$  inch (16 mm) minimum, and 2 inches (51 mm) maximum.

**EXCEPTION:** Where separate raised and visual characters with the same information are provided, the height of the raised uppercase letter “I” shall be permitted to be  $\frac{1}{2}$  inch (13 mm) minimum.



*Figure 703.3.5 – Character height*

**703.3.6 Character Width.** The uppercase letter “O” shall be used to determine the allowable width of all characters of a font. The width of the uppercase letter “O” of the font shall be 55 percent minimum and 110 percent maximum of the height of the uppercase “I” of the font.

**703.3.7 Stroke Width.** Raised character stroke width shall comply with Section 703.3.7. The uppercase letter “I” of the font shall be used to determine the allowable stroke width of all characters of a font.

**703.3.7.1 Maximum.** The stroke width shall be 15 percent maximum of the height of the uppercase letter “I” measured at the top surface of the character, and 30 percent maximum of the height of the uppercase letter “I” measured at the base of the character.

**703.3.7.2 Minimum.** When characters are both visual and raised, the stroke width shall be 10 percent minimum of the height of the uppercase letter “I”.

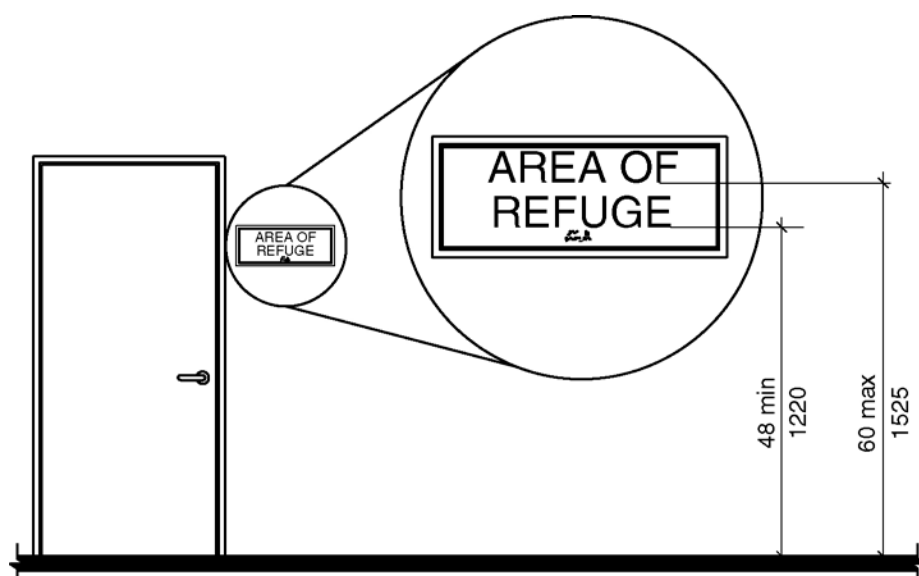


**703.3.8 Character Spacing.** Character spacing shall be measured between the two closest points of adjacent raised characters within a message, excluding word spaces. Spacing between individual raised characters shall be 1/8 inch (3.2 mm) minimum, at the top of the surface of the characters, 1/16 inch (1.6 mm) minimum measured at the base of the characters. Characters shall be separated from raised borders and decorative elements 3/8 inch (9.5 mm) minimum. (7-23-12 PC1)

**703.3.9 Line Spacing.** Spacing between the baselines of separate lines of raised characters within a message shall be 135 percent minimum and 170 percent maximum of the raised character height.

**703.3.10 Height above Floor.** Raised characters shall be 48 inches (1220 mm) minimum above the floor, measured to the baseline of the lowest raised character and 60 inches (1525 mm) maximum above the floor, measured to the baseline of the highest raised character.

**EXCEPTION:** Raised characters for elevator car controls shall not be required to comply with Section 703.3.10.



Note: For braille character mounting height see Section 703.4.5

Figure 703.3.10 – Height of raised characters above floor

**703.3.11 Location.** Where a sign containing raised characters and braille is provided at a door, the sign shall be alongside the door at the latch side. Where a sign containing raised characters and braille is provided at double doors with one active leaf, the sign shall be located on the inactive leaf. Where a sign containing raised characters and braille is provided at double doors with two active leaves, the sign shall be to the right of the right-hand door. Where there is no wall space on the latch side of a single door, or to the right side of double doors, signs shall be on the nearest adjacent wall. Signs containing raised characters and braille shall be located so that a clear floor area 18 inches (455 mm) minimum by 18 inches (455 mm) minimum, centered on the raised characters is provided beyond the arc of any door swing between the closed position and 45 degree open position.

**EXCEPTION:** Signs containing raised characters and braille shall be permitted on the push side of doors with closers and without hold-open devices.

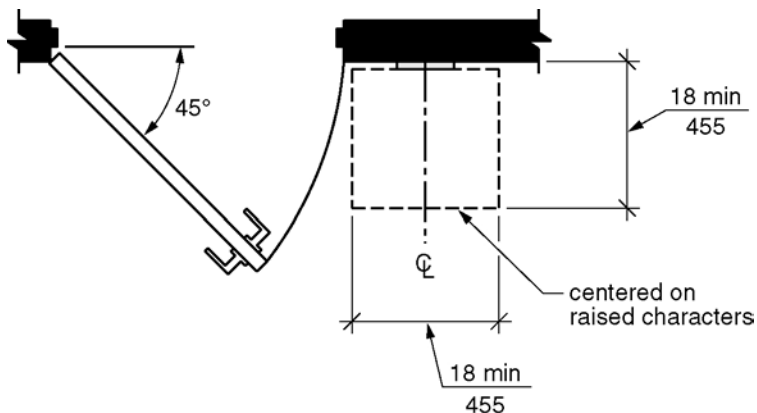


Figure 703.3.11 – Location of signs at doors

**703.3.12 Finish and Contrast.** Characters and their background shall have a non-glare finish. Characters shall contrast with their background with either light characters on a dark background, or dark characters on a light background.

**EXCEPTION:** Where separate raised characters and visual characters with the same information are provided, raised characters shall not be required to have nonglare finish or to contrast with their background.

**703.4 Braille.**

**703.4.1 General.** Braille shall be contracted (Grade 2) braille and shall comply with Section 703.4.

**703.4.2 Uppercase Letters.** The indication of an uppercase letter or letters shall only be used before the first word of sentences, proper nouns and names, individual letters of the alphabet, initials, or acronyms.

**703.4.3 Dimensions.** Braille dots shall have a domed or rounded shape and shall comply with Table 703.4.3.

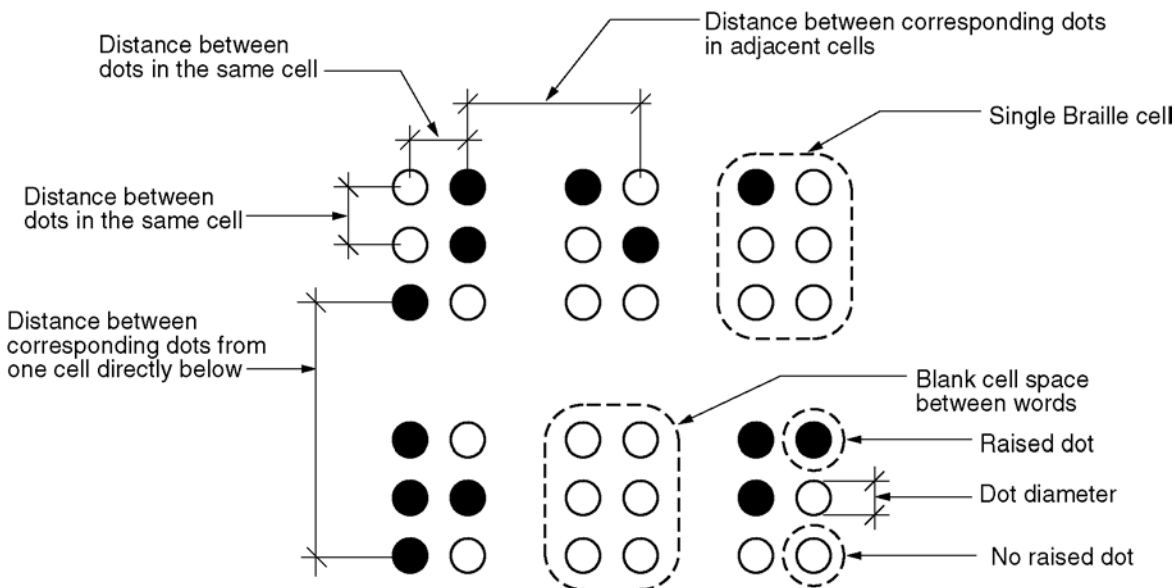


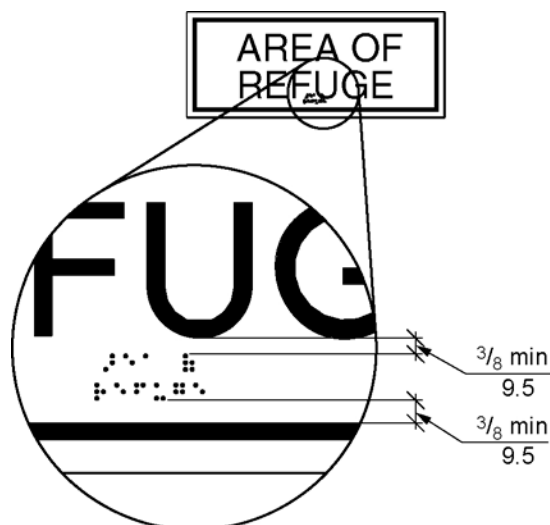
Figure 703.4.3 – Braille measurement

**Table 703.4.3— Braille Dimensions**

Measurement range	Minimum in inches Maximum in inches
Dot base diameter	0.059 (1.5 mm) to 0.063 (1.6 mm)
Distance between two dots in the same cell	0.090 (2.3 mm) to 0.100 (2.5 mm)
Distance between corresponding dots in adjacent cells <sup>1</sup>	0.241 (6.1 mm) to 0.300 (7.6 mm)
Dot height	0.025 (0.6 mm) to 0.037 (0.9 mm)
Distance between corresponding dots from one cell directly below <sup>1</sup>	0.395 (10.0 mm) to 0.400 (10.2 mm)

1. Measured center to center

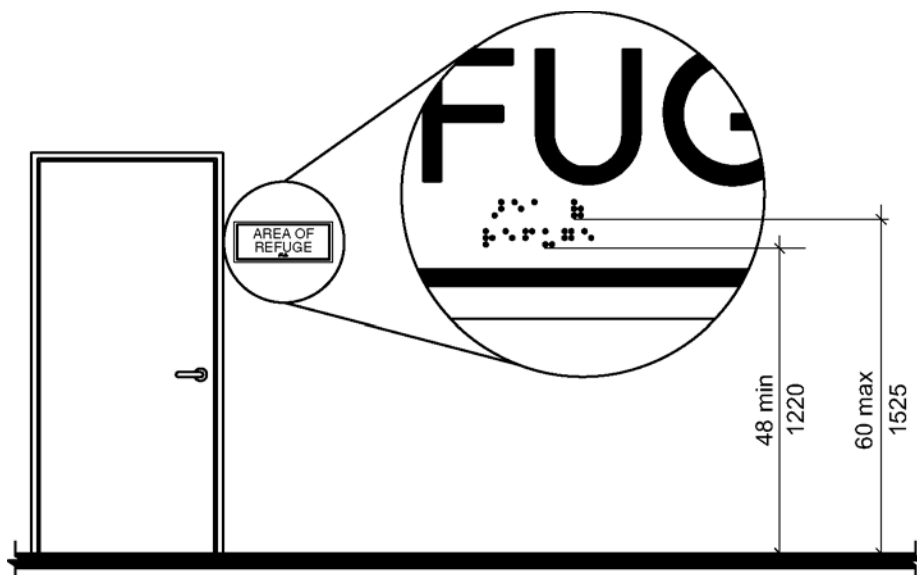
**703.4.4 Position.** Braille shall be below the corresponding text. If text is multi-lined, braille shall be placed below entire text. Braille shall be separated  $\frac{3}{8}$  inch (9.5 mm) minimum from any other raised characters and  $\frac{3}{8}$  inch (9.5 mm) minimum from raised borders and decorative elements. Braille provided on elevator car controls shall be separated  $\frac{3}{16}$  inch (4.8 mm) minimum either directly below or adjacent to the corresponding raised characters or symbols.



*Figure 703.4.4 – Positions of braille*

**703.4.5 Mounting Height.** Braille shall be 48 inches (1220 mm) minimum and 60 inches (1525 mm) maximum above the floor, measured to the baseline of the braille cells.

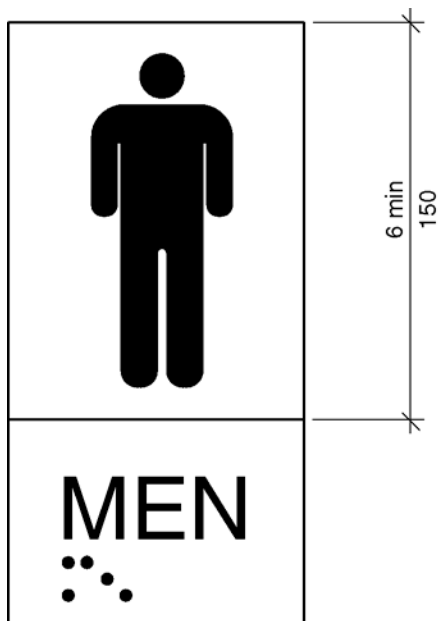
**EXCEPTION:** Elevator car controls shall not be required to comply with Section 703.4.5.



Note: For raised character mounting height see Section 703.3.10

**Figure 703.4.5 - Height of braille characters above floor**

**703.5 Pictograms.**



**Figure 703.5 – Pictogram field**

**703.5.1 General.** Pictograms shall comply with Section 703.5.

**703.5.2 Pictogram Field.** Pictograms shall have a field 6 inches (150 mm) minimum in height. Characters or braille shall not be located in the pictogram field.

**703.5.3 Finish and Contrast.** Pictograms and their fields shall comply with Sections 703.5.3.1 and 703.5.3.2 have a nonglare finish. Pictograms shall contrast with their fields, with either light pictograms on a dark field, or dark pictograms on a light field. ~~(7-1-12/3.1 – PC3.3 Agenda Item #35.3 )~~

**703.5.3.1 Nonglare Finish.** The glare from coverings and the finish of pictograms and their fields shall

not exceed 19 **gloss units (gu)** as measured on a 60-degree gloss meter. (7-1-12/3.1-PC 3.3)

~~703.5.3.2 Contrast. The Light Reflectance Value (LRV) of pictograms and their fields shall contrast 70 percent minimum as determined in accordance with Equation 7-1. The lighter surface shall have a LRV of not less than 45. Characters shall contrast with their background, with either light characters on a dark background or dark characters on a light background. (7-1-12/3.1 – PC3.3 Agenda Item #35.3 )~~

## 703.6 Symbols of Accessibility.

**703.6.1 General.** Symbols of accessibility shall comply with Section 703.6.

~~703.6.2 Finish and Contrast. Symbols of accessibility and their backgrounds shall comply with Sections 703.6.2.1 and 703.6.2.2 have a non-glare finish. Symbols of accessibility shall contrast with their backgrounds with either a light symbol on a dark background or a dark symbol on a light background. (7-1-12/3.1 – PC3.3 Agenda Item #35.3 )~~

**703.6.2.1 Nonglare Finish.** The glare from coverings and the finish of symbols of accessibility and their backgrounds shall not exceed 19 **gloss units (gu)** as measured on a 60-degree gloss meter. (7-1-12/3.1-PC 3.3)

~~703.6.2.2 Contrast. The Light Reflectance Value (LRV) of symbols of accessibility and their backgrounds shall contrast 70 percent minimum, as determined in accordance with Equation 7-1. The lighter surface shall have a LRV of not less than 45. (7-1-12/3.1 – PC3.3 Agenda Item #35.3 )~~

## 703.6.3 Symbols.

**703.6.3.1 International Symbol of Accessibility.** The International Symbol of Accessibility shall comply with Figure 703.6.3.1.



*Figure 703.6.6.1 - International symbol or accessibility*

**703.6.3.2 International Symbol of TTY.** The International Symbol of TTY shall comply with Figure 703.6.3.2.



*Figure 703.6.6.2 - International TTY Symbol*

**703.6.3.3 Assistive Listening Systems.** Assistive listening systems shall be identified by the International Symbol of Access for Hearing Loss complying with Figure 703.6.3.3.



*Figure 703.6.6.3 - International symbol of access for hearing loss*

**703.6.3.4 Volume-Controlled Telephones.** Telephones with volume controls shall be identified by a pictogram of a telephone handset with radiating sound waves on a square field complying with Figure 703.6.3.4.



*Figure 703.6.6.4 - Volume control telephone*

### **703.7 Variable Message Signs.**

**703.7.1 General.** High resolution variable message sign (VMS) characters shall comply with Sections 703.2 and 703.7.12 through 703.7.14. Low resolution variable message sign (VMS) characters shall comply with Section 703.7.

**EXCEPTION:** Theatrical performance related VMS signs, including but not limited to, text and translation delivery systems, surtitles and subtitles, shall not be required to comply with Section 703.7.1.

**703.7.2 Case.** Low resolution VMS characters shall be uppercase.

**703.7.3 Style.** Low resolution VMS characters shall be conventional in form, shall be sans serif, and shall not be italic, oblique, script, highly decorative, or of other unusual forms.

**703.7.4 Character Height.** The uppercase letter “I” shall be used to determine the allowable height of all low resolution VMS characters of a font. Viewing distance shall be measured as the horizontal distance between the character and an obstruction preventing further approach towards the sign. The uppercase letter “I” of the font shall have a minimum height complying with Table 703.7.4.

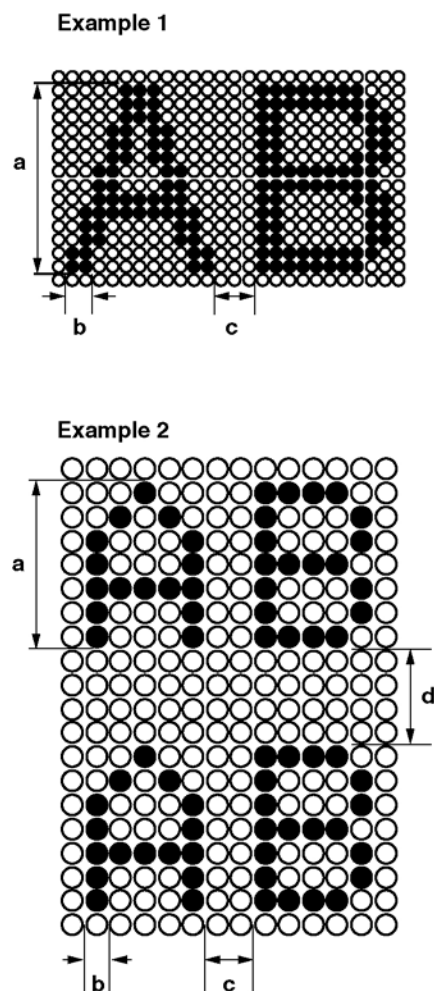
**EXCEPTION:** In assembly seating where the maximum viewing distance is 100 feet (30.5 m) or greater, the height of the uppercase “I” of low resolution VMS fonts shall be permitted to be 1 inch (25.4 mm) for every 30 feet (9.1 m) of viewing distance, provided the character height is 8 inches (205 mm) minimum. Viewing distance shall be measured as the horizontal distance between the character and where someone is expected to view the sign.

**Table 703.7.4—Low Resolution VMS Character Height**

<b>Height above Floor to Baseline of Character<sup>1</sup></b>	<b>Horizontal Viewing Distance<sup>2</sup></b>	<b>Minimum Character Height</b>
40 inches (1015 mm) to less than or equal to 70 inches (1780 mm)	Less than 10 feet (3048 mm)	2 inches (51 mm)
	10 feet (3048 mm) and greater	2 inches (51 mm), plus 1/5 inch (5.1 mm) per foot (305 mm) of viewing distance above 10 feet (3048 mm)
Greater than 70 inches (1780 mm) to less than or equal to 120 inches (3050 mm)	Less than 15 feet (4570 mm)	3 inches (76 mm)
	15 feet (4570 mm) and greater	3 inches (76 mm), plus 1/5 inch (5.1 mm) per foot (305 mm) of viewing distance above 15 feet (4570 mm)
Greater than 120 inches (3050 mm)	Less than 20 feet (6096 mm)	4 inches (102 mm)
	20 feet (6096 mm) and greater	4 inches (100 mm), plus 1/5 inch (5.1 mm) per foot (305 mm) of viewing distance above 20 feet (6096 mm)

1. The vertical height is measured from the floor of the viewing position to the baseline of the highest line of characters.
2. ~~The horizontal viewing distance shall be measured as the horizontal distance between the character and an obstruction preventing further approach towards the sign or where applicable, as stated in the exception to Section 703.7.4. (7-6-12) (ed.)~~

**703.7.5 Character Width.** The uppercase letter “O” shall be used to determine the allowable width of all low resolution VMS characters of a font. Low resolution VMS characters shall comply with the pixel count for character width in Table 703.7.5.



	Property	Example 1	Example 2
<b>a</b>	Character Height	14 Pixels	7 Pixels
<b>b</b>	Stroke Width	2 Pixels	1 Pixel
<b>c</b>	Character Spacing	3 Pixels	2 Pixels
<b>d</b>	Line Spacing		4 Pixels

*Figure 703.7.5 – Low resolution VMS Signage characters*

**Table 703.7.5 Pixel count for Low Resolution VMS Signage<sup>1</sup>**

Character Height	Character Width Range	Stroke Width Range	Character Spacing Range
7	5-6	1	2
8	6-7	1-2	2-3
9	6-8	1-2	2-3
10	7-9	2	2-4
11	8-10	2	2-4
12	8-11	2	3-4
13	9-12	2-3	3-5
14	10-13	2-3	3-5
15	11-14	2-3	3-5



(1) Measured in pixels.

**703.7.6 Stroke Width.** The uppercase letter “I” shall be used to determine the allowable stroke width of all low resolution VMS characters of a font. Low resolution VMS characters shall comply with the pixel count for stroke width in Table 703.7.5.

**703.7.7 Character Spacing.** Spacing shall be measured between the two closest points of adjacent low resolution VMS characters within a message, excluding word spaces. Low resolution VMS character spacing shall comply with the pixel count for character spacing in Table 703.7.5.

**703.7.8 Line Spacing.** Low resolution VMS characters shall comply with Section 703.2.8.

**703.7.9 Height Above Floor.** Low resolution VMS characters shall be 40 inches (1015 mm) minimum above the floor of the viewing position, measured to the baseline of the character. Heights of low resolution variable message sign characters shall comply with Table 703.7.4, based on the size of the characters on the sign.

**703.7.10 Finish.** The background of Low resolution VMS characters shall have a non-glare finish.

**703.7.11 Contrast.** Low resolution VMS characters shall be light characters on a dark background.

**703.7.12 Protective Covering.** Where a protective layer is placed over VMS characters through which the VMS characters must be viewed, the protective covering shall have a non-glare finish.

**703.7.13 Brightness.** The brightness of variable message signs in exterior locations shall automatically adjust in response to changes in ambient light levels.

**703.7.14 Rate of Change.** Where a VMS message can be displayed in its entirety on a single screen, it shall be displayed on a single screen and shall remain motionless on the screen for a minimum 3 seconds or one second minimum for every 7 characters of the message including spaces whichever is longer.

## **703.8 Remote Infrared Audible Sign (RIAS) Systems.**

**703.8.1 General.** Remote Infrared Audible Sign Systems shall comply with Section 703.8.

**703.8.2 Transmitters.** Where provided, Remote Infrared Audible Sign Transmitters shall be designed to communicate with receivers complying with Section 703.8.3.

### **703.8.3 Infrared Audible Sign Receivers.**

**703.8.3.1 Frequency.** Basic speech messages shall be frequency modulated at 25 kHz, with a +/- 2.5 kHz deviation, and shall have an infrared wavelength from 850 to 950 nanometer (nm).

**703.8.3.2 Optical Power Density.** Receiver shall produce a 12 decibel (dB) signal-plus-noise-to-noise ratio with a 1 kHz modulation tone at +/- 2.5 kHz deviation of the 25 kHz subcarrier at an optical power density of 26 picowatts per square millimeter measured at the receiver photosensor aperture.

**703.8.3.3 Audio Output.** The audio output from an internal speaker shall be at 75 dBA minimum at 18 inches (455 mm) with a maximum distortion of 10 percent.

**703.8.3.4 Reception Range.** The receiver shall be designed for a high dynamic range and capable of operating in full-sun background illumination.

**703.8.3.5 Multiple Signals.** A receiver provided for the capture of the stronger of two signals in the receiver field of view shall provide a received power ratio on the order of 20 dB for negligible interference.

**703.9 Pedestrian Signals.** Accessible pedestrian signals shall comply with Section 4E.06 - Accessible Pedestrian Signals, and Section 4E.09 - Accessible Pedestrian Signal Detectors, of the Manual on Uniform Traffic Control Devices listed in Section 106.2.4.

**EXCEPTION:** Pedestrian signals shall not be required to comply with the requirement for choosing audible tones.

## 704 Telephones

**704.1 General.** Accessible public telephones shall comply with Section 704. (ed.)

**704.2 Wheelchair Accessible Telephones.** Wheelchair accessible public telephones shall comply with Section 704.2.

**EXCEPTION:** Drive up only public telephones shall not be required to be provided with a clear floor space complying with Section 704.2.1. (7-14-12) (ed.)

**704.2.1 Clear Floor Space.** A clear floor space complying with Section 305 shall be provided. The clear floor space shall not be obstructed by bases, enclosures, or seats.

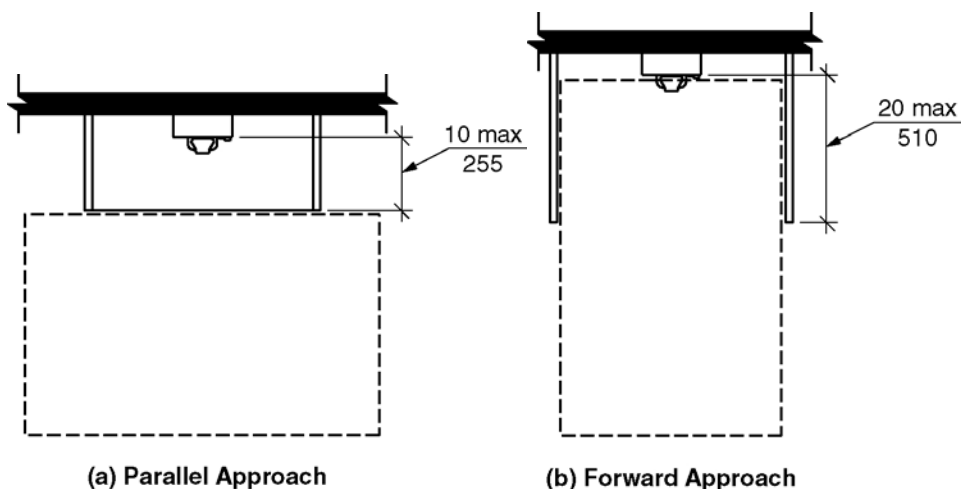


Figure 704.2.1 - Clear floor space for telephones

**704.2.1.1 Parallel Approach.** Where a parallel approach is provided, the distance from the edge of the telephone enclosure to the face of the telephone shall be 10 inches (255 mm) maximum.

**704.2.1.2 Forward Approach.** Where a forward approach is provided, the distance from the front edge of a counter within the enclosure to the face of the telephone shall be 20 inches (510 mm) maximum.

**704.2.2 Operable Parts.** Operable parts shall comply with Section 309. Telephones shall have push button controls where service for such equipment is available.

**704.2.3 Telephone Directories.** Where provided, telephone directories shall comply with Section 309.

**704.2.4 Cord Length.** The telephone handset cord shall be 29 inches (735 mm) minimum in length.

**704.3 Volume-Control Telephones.** Public telephones required to have volume controls shall be equipped with a receiver volume control that provides a gain adjustable up to 20 dB minimum. Incremental volume controls shall provide at least one intermediate step of gain of 12 dB minimum. An automatic reset shall be provided.

**704.4 TTY.** TTYs required at a public pay telephone shall be permanently affixed within, or adjacent to, the telephone enclosure. Where an acoustic coupler is used, the telephone cord shall be of sufficient length to allow connection of the TTY and the telephone receiver.

**704.5 Height.** When in use, the touch surface of TTY keypads shall be 34 inches (865 mm) minimum above the floor.

**EXCEPTION:** Where seats are provided, TTYs shall not be required to comply with Section 704.5.

**704.6 TTY Shelf.** Where public pay telephones designed to accommodate a portable TTY are provided, they shall be equipped with a shelf and an electrical outlet within or adjacent to the telephone enclosure. The telephone handset shall be capable of being placed flush on the surface of the shelf. The shelf shall be capable of accommodating a TTY and shall have a vertical clearance 6 inches (150 mm) minimum in height above the area where the TTY is placed.

**704.7 Visual Relay Service Booth.** Each public Visual Relay Service Booth shall be accommodate one user with seating and privacy enclosure, a two-way video communication system, diffuse lighting with a minimum lighting level of 20 foot candles (215 lux). The background of the seating area, and within range of the two-way video communication system, shall have a flat, non-textured surface and finish color in the bright green or blue range.(7-16-12 PC2.1)

## **705 Detectable Warning Surfaces**

**705.1 General.** Detectable warning surfaces shall comply with Section 705.

**705.2 Standardization.** Detectable warning surfaces shall be standard within a building, facility, site, or complex of buildings.

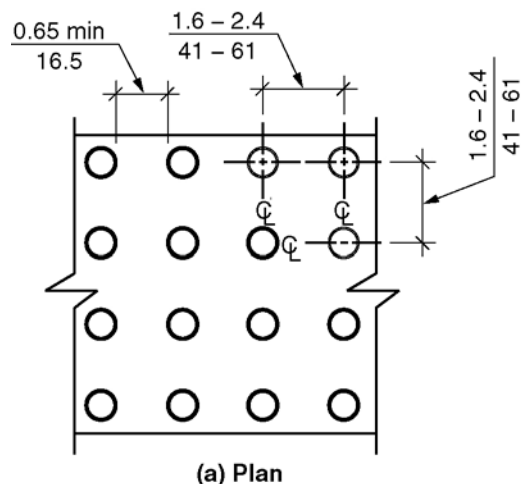
**EXCEPTION:** In facilities that have both interior and exterior locations, detectable warnings in exterior locations shall not be required to comply with Section 705.4.

**705.3 Contrast.** Detectable warning surfaces shall contrast visually with adjacent surfaces.~~The Light Reflectance Value (LRV) of the surfaces shall contrast 70 percent minimum, as determined in accordance with Equation 7-1. The lighter surface shall have a LRV of not less than 45 either light-on-dark or dark-on-light. (7-1-12 PC3, PC3.1) (7-1-12/3.1 – PC3.3 Agenda Item #35.1 )~~

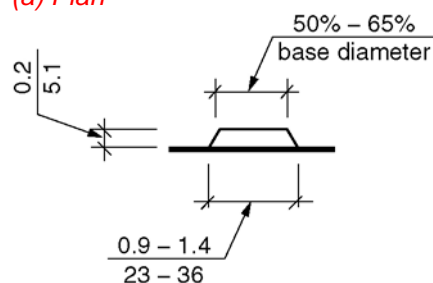
**705.4 Interior Locations.** Detectable warning surfaces in interior locations shall differ from adjoining walking surfaces in resiliency or sound-on-cane contact.

**705.5 Truncated Domes.** Detectable warning surfaces shall have truncated domes complying with Section 705.5.

*Figure 705.5 - Truncated dome size and spacing*



(a) Plan



(b) Elevation (enlarged)

**705.5.1 Size.** Truncated domes shall have a base diameter of 0.9 inch (23 mm) minimum and 1.4 inch (36 mm) maximum, and a top diameter of 50 percent minimum and 65 percent maximum of the base diameter.

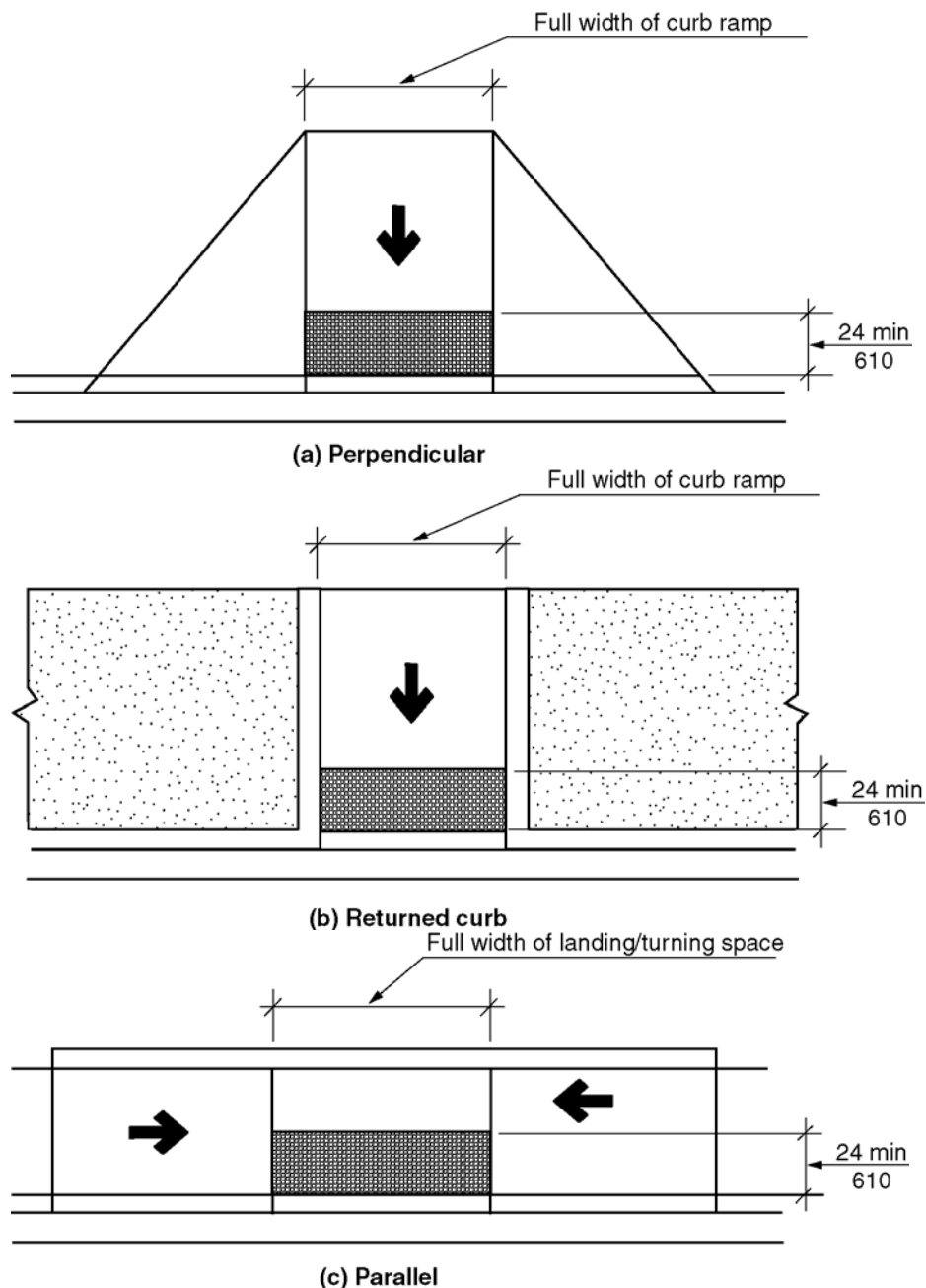
**705.5.2 Height.** Truncated domes shall have a height of 0.2 inch (5.1 mm).

**705.5.3 Spacing.** Truncated domes shall have a center-to-center spacing of 1.6 inches (41 mm) minimum and 2.4 inches (61 mm) maximum, and a base-to-base spacing of 0.65 inch (16.5 mm) minimum, measured between the most adjacent domes on the grid.

**705.5.4 Alignment.** Truncated domes shall be aligned in a square or radial grid pattern.(7-18-12)

**705.6 Depth and width of detectable warnings surfaces.** Detectable warnings shall comply with the following:

1. Detectable warning surfaces shall extend 24 inches (610 mm) minimum in the direction of pedestrian travel.
2. At curb ramps and blended transitions, detectable warning surfaces shall extend the full width of the curb ramp run excluding any flared sides or blended transition.
3. At pedestrian at-grade rail crossings not located within a street or highway, detectable warnings shall extend the full width of the crossing.
4. At boarding platforms for buses and rail vehicles, detectable warning surfaces shall extend the full length of the public use areas of the platform.
5. At boarding and alighting areas at sidewalk or street level transit stops for rail vehicles, detectable warning surfaces shall extend the full length of the transit stop. (4-44-12) (ed.)



*Figure 705.6 Extent of detectable warning surfaces*  
*a) perpendicular*  
*b) returned curb*  
*c) parallel*

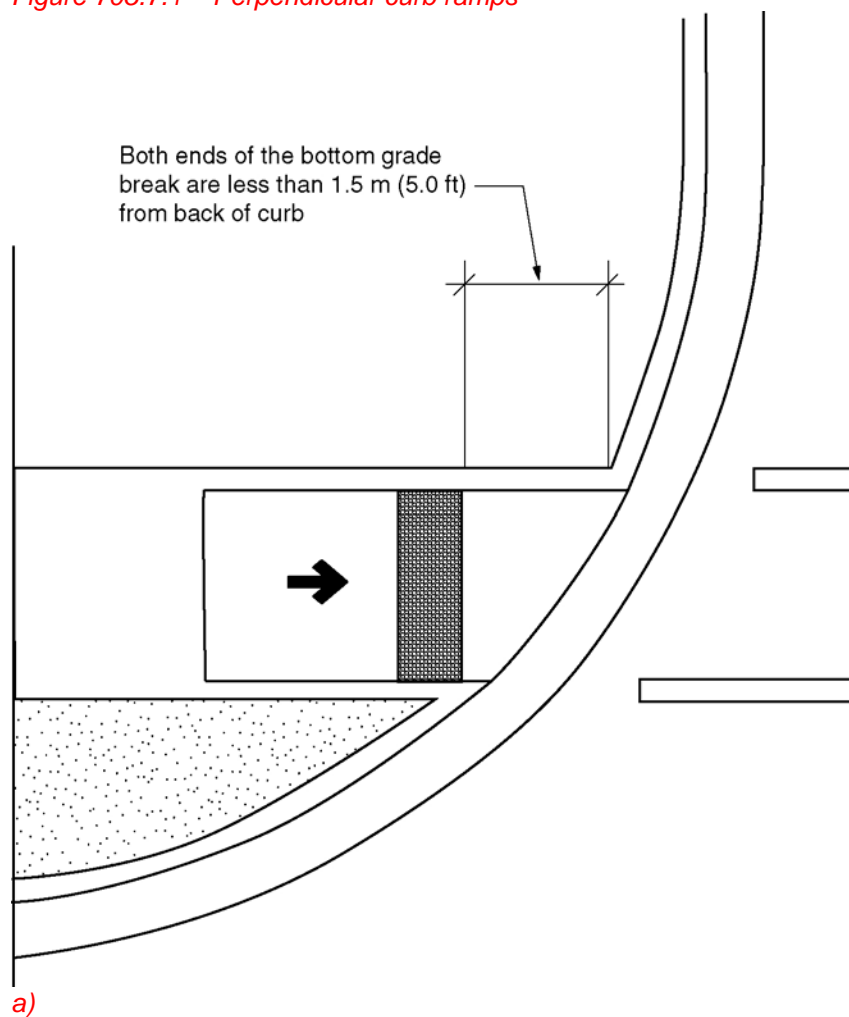
**705.7 Placement.** The placement of detectable warning surfaces shall comply with Section 705.7. (4-44-12)

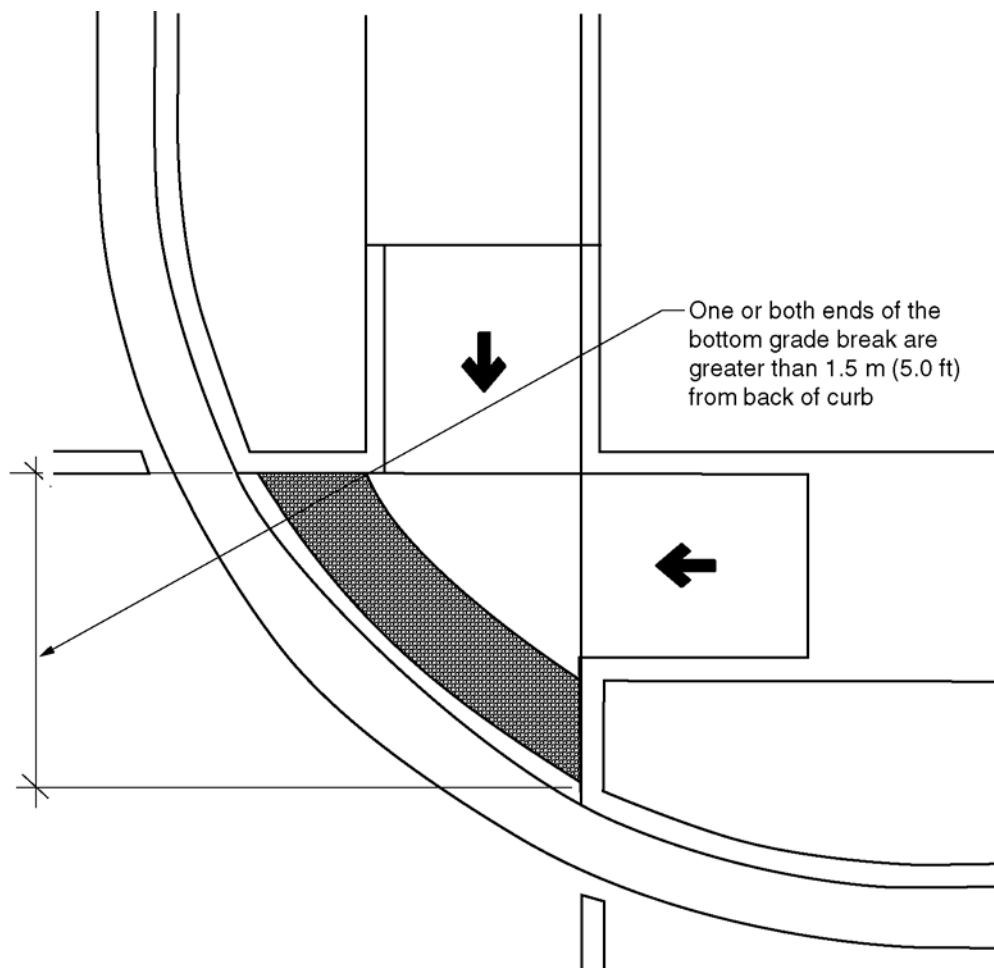
**705.7.1 Perpendicular Curb Ramps.** On perpendicular curb ramps, detectable warning surfaces shall be placed as follows:

1. Where the ends of the bottom grade break are in front of the back of curb, detectable warning surfaces shall be placed at the back of curb.

2. Where the ends of the bottom grade break are behind the back of curb and the distance from either end of the bottom grade brake to the back of curb is 60 inches (1525 mm) or less, detectable warning surfaces shall be placed on the ramp run within one dome spacing of the bottom grade break.
3. Where the ends of the bottom grade break are behind the back of curb and the distance from either end of the bottom grade brake to the back of curb is more than 60 inches (1525 mm), detectable warning surfaces shall be placed on the lower landing at the back of curb. (4-44-12)

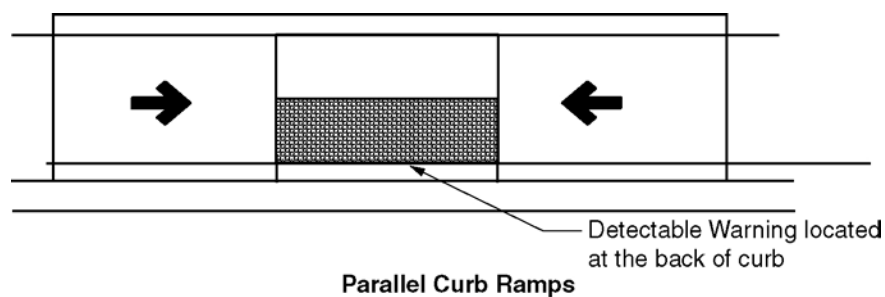
*Figure 705.7.1 – Perpendicular curb ramps*





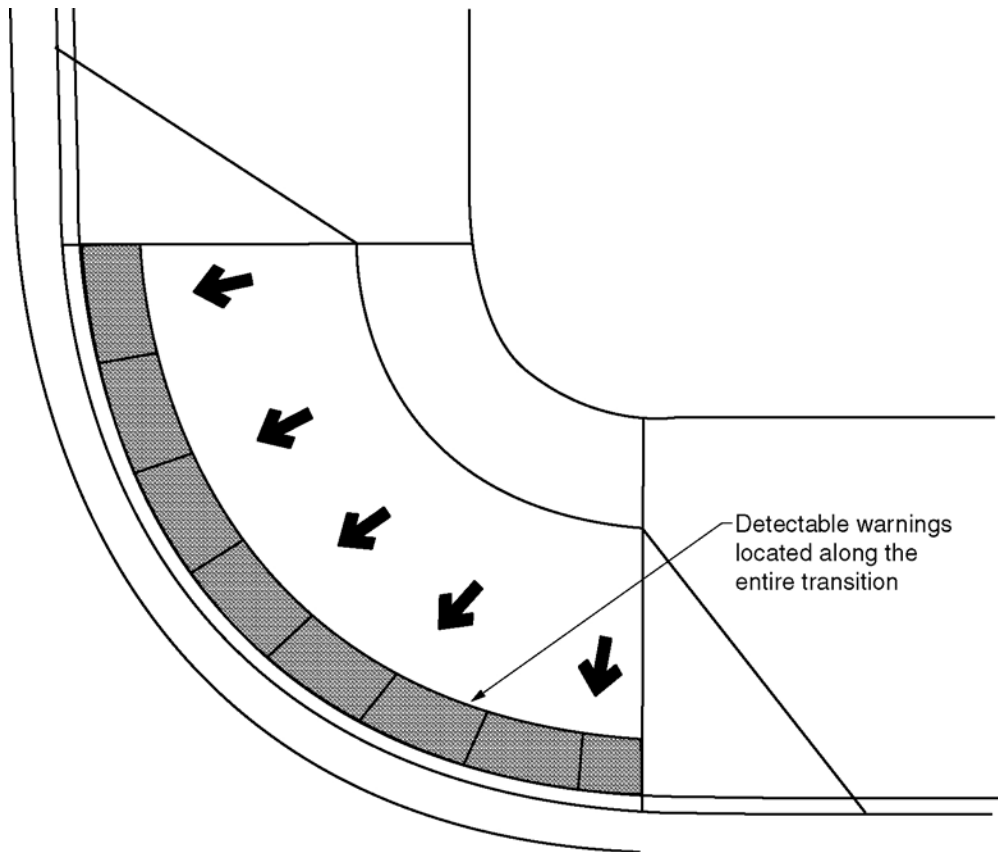
b)

**705.7.2 Parallel Curb Ramps.** On parallel curb ramps, detectable warning surfaces shall be placed on the turning space at the flush transition between the street and sidewalk. (4-44-12)



*Figure 705.7.2– Parallel curb ramps*

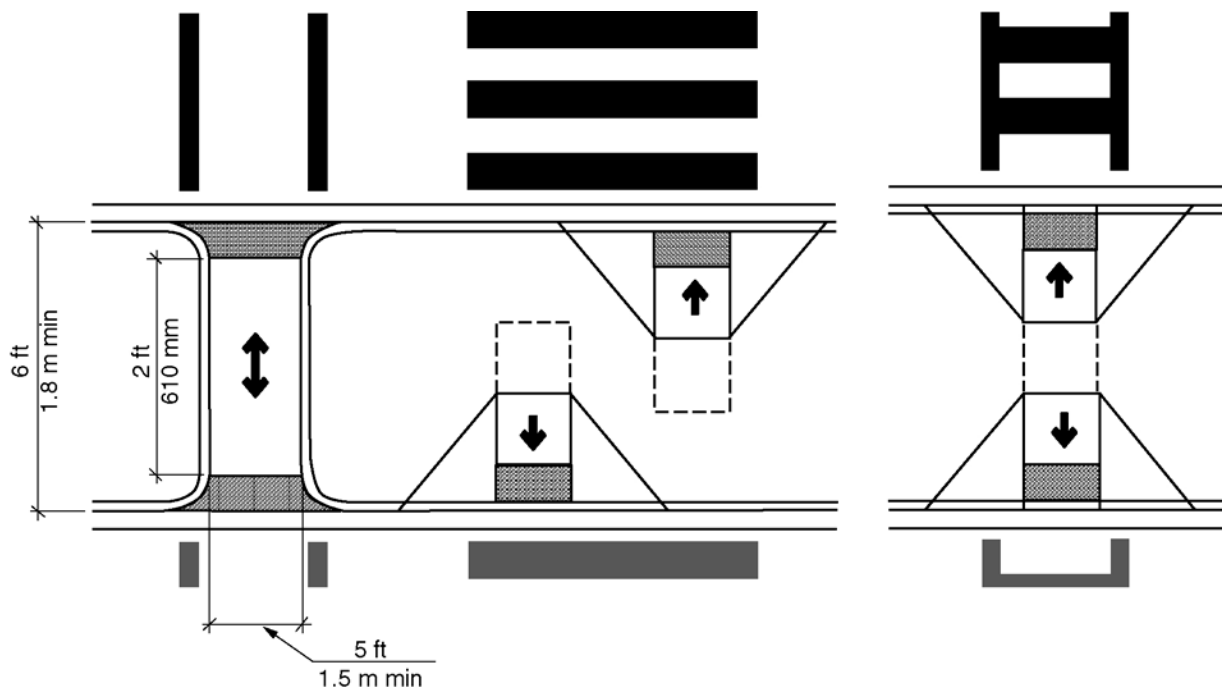
**705.7.3 Blended Transitions.** On blended transitions, detectable warning surfaces shall be placed at the back of curb. Where raised pedestrian street crossings, depressed corners, or other level pedestrian street crossings are provided, detectable warning surfaces shall be placed at the flush transition between the street and the sidewalk. (4-44-12)



*Figure 705.7.3 – Blended transitions*

**705.7.4 Pedestrian Refuge Islands.** At cut-through pedestrian refuge islands, detectable warning surfaces shall be placed at the edges of the pedestrian island and shall be separated by a 24 inches (610 mm) minimum length of surface without detectable warnings. (4-44-12)

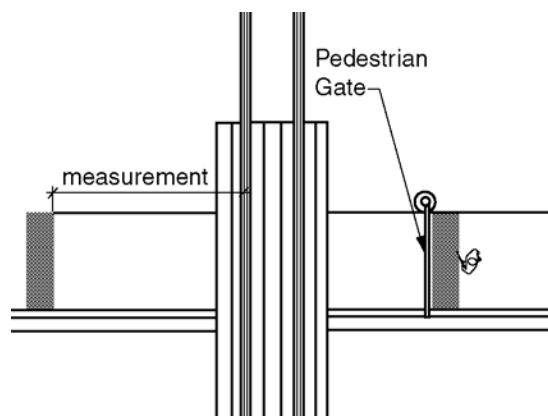




**Pedestrian Refuge Islands**

*Figure 705.7.4– Pedestrian refuge islands*

**705.7.5 Pedestrian At-Grade Rail Crossings.** At pedestrian at-grade rail crossings not located within a street or highway, detectable warning surfaces shall be placed on each side of the rail crossing. The edge of the detectable warning surface nearest the rail crossing shall be 72 inches (1829) minimum and 15 feet (4679 mm) maximum from the centerline of the nearest rail. Where pedestrian gates are provided, detectable warning surfaces shall be placed on the side of the gates opposite the rail. (4-44-12)



**Pedestrian At-Grade Rail Crossing**

*Figure 705.7.5 – Pedestrian at-grade rail crossings*

**705.7.6 Boarding Platforms.** At boarding platforms for buses and rail vehicles, detectable warning surfaces shall be placed at the boarding edge of the platform. (4-44-12)

**705.7.7 Boarding and Alighting Areas.** At boarding and alighting areas at sidewalk or street level transit stops for rail vehicles, detectable warning surfaces shall be placed at the side of the boarding and alighting area facing the rail vehicles. (4-44-12)

## 706 Assistive Listening Systems

**706.1 General.** Where installed, assistive listening systems shall comply with 706. (7-19-12)

**706.2 Receiver Jacks.** Receivers required for use with an assistive listening system shall include a  $\frac{1}{8}$  inch (3.2 mm) standard monaural (monophonic) jack. (7-20-12)

**706.3 Induction Loop Systems.** Where induction hearing loop systems are provided, they shall comply with IEC-60118-4 as listed in Section 106.2.2. (7-19-12)

**706.4 Receiver Hearing-Aid Compatibility.** Receivers required to be hearing aid compatible shall interface with telecoils in hearing aids through the provision of neck loops.

**706.5 Sound Pressure Level.** Assistive listening systems shall be capable of providing a sound pressure level of 110 dB minimum and 118 dB maximum, with a dynamic range on the volume control of 50 dB.

**706.6 Signal-to-Noise Ratio.** The signal-to-noise ratio for internally generated noise in assistive listening systems shall be 18 dB minimum.

**706.7 Peak Clipping Level.** Peak clipping shall not exceed 18 dB of clipping relative to the peaks of speech.

## 707 Automatic Teller Machines (ATMs) and Fare Machines

**707.1 General.** Accessible automatic teller machines and fare machines shall comply with Section 707. (ed.)

**707.2 Clear Floor Space.** A clear floor space complying with Section 305 shall be provided in front of the machine.

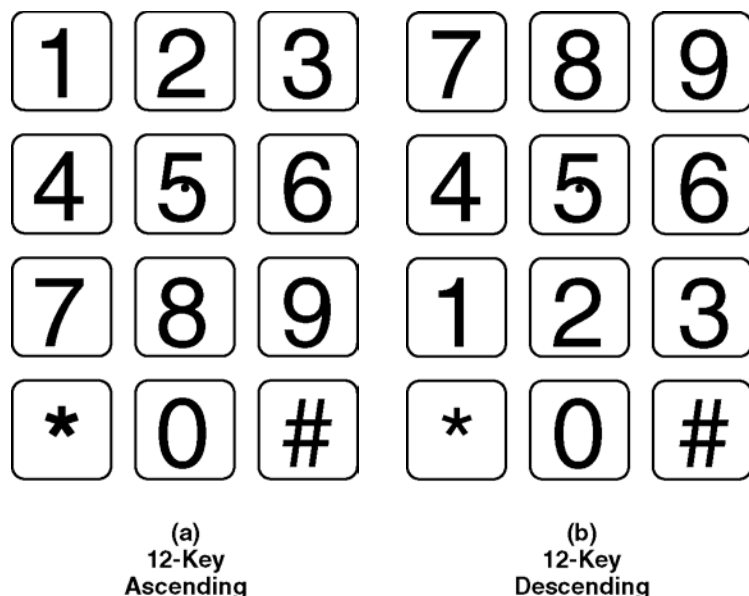
**EXCEPTION:** Clear floor space is not required at drive up only automatic teller machines and fare machines.

**707.3 Operable Parts.** Operable parts shall comply with Section 309. Unless a clear or correct key is provided, each operable part shall be able to be differentiated by sound or touch, without activation.

**EXCEPTION:** Drive up only automatic teller machines and fare machines shall not be required to comply with Section 309.2 or 309.3.

**707.4 Privacy.** Automatic teller machines shall provide the opportunity for the same degree of privacy of input and output available to all individuals.

**707.5 Numeric Keys.** Numeric keys shall be arranged in a 12-key ascending or descending telephone keypad layout. The number Five key shall have a single raised dot.



*Figure 707.5 (a) & (b) Numeric*

*Key Layout*

**707.6 Function Keys.** Function keys shall comply with Section 707.6.

**707.6.1 Raised Symbols.** Function key surfaces shall have raised symbols as shown in Table 707.6.1.

**TABLE 707.6.1—RAISED SYMBOLS**

Key Function	Description of Raised Symbol	Raised Symbol
Enter or Proceed:	CIRCLE	○
Clear or Correct:	LEFT ARROW	← or <
Cancel:	“X”	X
Add Value:	PLUS SIGN	+
Decreased Value:	MINUS SIGN	-

(7-21-12)

**707.6.2 Contrast.** Function keys shall contrast visually from background surfaces. Characters and symbols on key surfaces shall contrast visually from key surfaces. Visual contrast shall be either light-on-dark or dark-on-light.

**EXCEPTION:** Raised symbols required by Section 707.6.1 shall not be required to comply with Section 707.6.2.

**707.7 Display Screen.** The display screen shall comply with Section 707.7.

**707.7.1 Visibility.** The display screen shall be visible from a point located 40 inches (1015 mm) above the center of the clear floor space in front of the machine.

**EXCEPTION:** Drive up only automatic teller machines and fare machines shall not be required to comply with Section 707.7.1.

**707.7.2 Characters** Characters displayed on the screen shall be in a sans serif font. The uppercase letter “I” shall be used to determine the allowable height of all characters of the font. The uppercase letter “I” of the font shall be  $\frac{3}{16}$  inch (4.8 mm) minimum in height. Characters shall contrast with their background with either light characters on a dark background, or dark characters on a light background.

**707.8 Speech Output.** Machines shall be speech enabled. Operating instructions and orientation, visible transaction prompts, user input verification, error messages, and all displayed information for full use shall be ~~accessible to and~~ independently usable by individuals with vision impairments. Speech shall be delivered through a mechanism that is readily available to all users including, but not limited to, an industry standard connector or a telephone handset. Speech shall be recorded or digitized human, or synthesized. (ed.)

**EXCEPTIONS:**

1. Audible tones shall be permitted in lieu of speech for visible output that is not displayed for security purposes, including but not limited to, asterisks representing personal identification numbers.
2. Advertisements and other similar information shall not be required to be audible unless they convey information that ~~is~~ used in the transaction being conducted. (ed.)
3. Where speech synthesis ~~is not~~ supported, dynamic alphabetic output shall not be required to be audible. (ed.)

**707.8.1 User Control.** Speech shall be capable of being repeated and interrupted by the user. There shall be a volume control for the speech function.

**EXCEPTION:** Speech output for any single function shall be permitted to be automatically interrupted when a transaction is selected.

**707.8.2 Receipts.** Where receipts are provided, speech output devices shall provide audible balance inquiry information, error messages, and all other information on the printed receipt necessary to complete or verify the transaction.

**EXCEPTIONS:**

1. Machine location, date and time of transaction, customer account number, and the machine identifier shall not be required to be audible.
2. Information on printed receipts that duplicates audible information available on-screen shall not be required to be presented in the form of an audible receipt.
3. Printed copies of bank statements and checks shall not be required to be audible.

**707.9 Input Controls.** At least one tactually discernible input control shall be provided for each function. Where provided, key surfaces not on active areas of display screens shall be raised above surrounding surfaces. Where membrane keys are the only method of input, each shall be tactually discernible from surrounding surfaces and adjacent keys.

**707.10 Braille Instructions.** Braille instructions for initiating the speech mode shall be provided. Braille shall comply with Section 703.4.

**708 Two-Way Communication Systems**

**708.1 General.** ~~Accessible~~ two-way communication systems shall comply with Section 708. (ed.)

**708.2 Audible and Visual Indicators.** The system shall provide both visual and audible signals.

**708.3 Handsets.** Handset cords, if provided, shall be 29 inches (735 mm) minimum in length.

**708.4 Telephone entry systems.** Telephone entry systems shall comply with DASMA 303 listed in Section **106.2.6**.



## Chapter 8. Special Rooms and Spaces

### 801 General

**801.1 Scope.** Special rooms and spaces required to be accessible by the scoping provisions adopted by the administrative authority shall comply with the applicable provisions of Chapter 8.

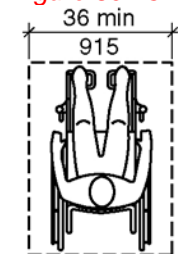
### 802 Assembly Areas

**802.1 General.** Wheelchair spaces and wheel chair space locations in assembly areas with spectator seating shall comply with Section 802. Where tiered seating includes dining surfaces or work surfaces, wheelchair spaces and wheelchair space locations shall comply with Section 802.6, 802.7, 802.9, 802.10 and 902. Team and player seating shall comply with Sections 802.2 through 802.7. (8-1-12). (8-2-12)

**802.2 Floor Surfaces.** The floor surface of wheelchair space locations shall have a slope not steeper than 1:48 and shall comply with Section 302.

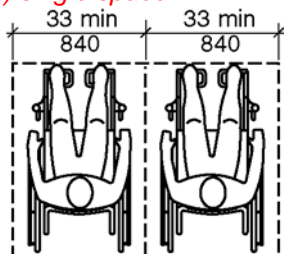
**802.3 Width.** A single wheelchair space shall be 36 inches (915 mm) minimum in width. Where two adjacent wheelchair spaces are provided, each wheelchair space shall be 33 inches (840 mm) minimum in width.

*Figure 802.3 – Width of wheelchair space in assembly area*



(a) Single Space

*a) single space*

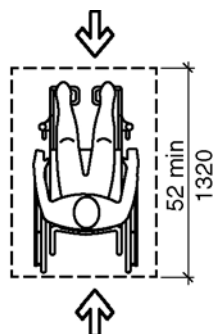


(b) Multiple Adjacent Spaces

*b) multiple adjacent space*

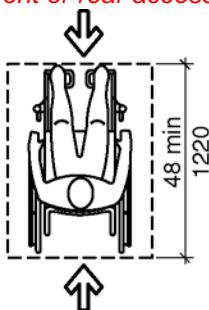
### 802.4 Depth.

*Figure 802.4 Depth of wheelchair space in assembly areas*



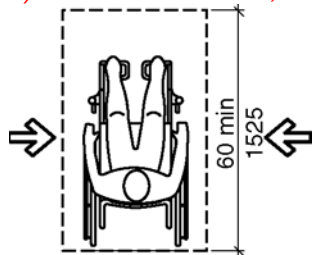
(a) Front or Rear Access  
New Buildings

*a) front or rear access, new buildings*



(b) Front or Rear Access  
Existing Building

*b) front or rear access, existing buildings*



(c) Side Access  
New and Existing Buildings

*c) side access, new and existing buildings*

**802.4.1 New buildings.** In new buildings, where a wheelchair space **is** entered from the front or rear, the wheelchair space shall be 52 inches (1320 mm) minimum in depth. Where a wheelchair space **is** only entered from the side, the wheelchair space shall be 60 inches (1525 mm) minimum in depth. (8-3-12) (ed.)

**802.4.2 Existing buildings.** In existing buildings, where a wheelchair space **is** entered from the front or rear, the wheelchair space shall be 48 inches (1220 mm) minimum in depth. Where a wheelchair space **is** only entered from the side, the wheelchair space shall be 60 inches (1525 mm) minimum in depth. (3-6-12 PC2) (ed.)

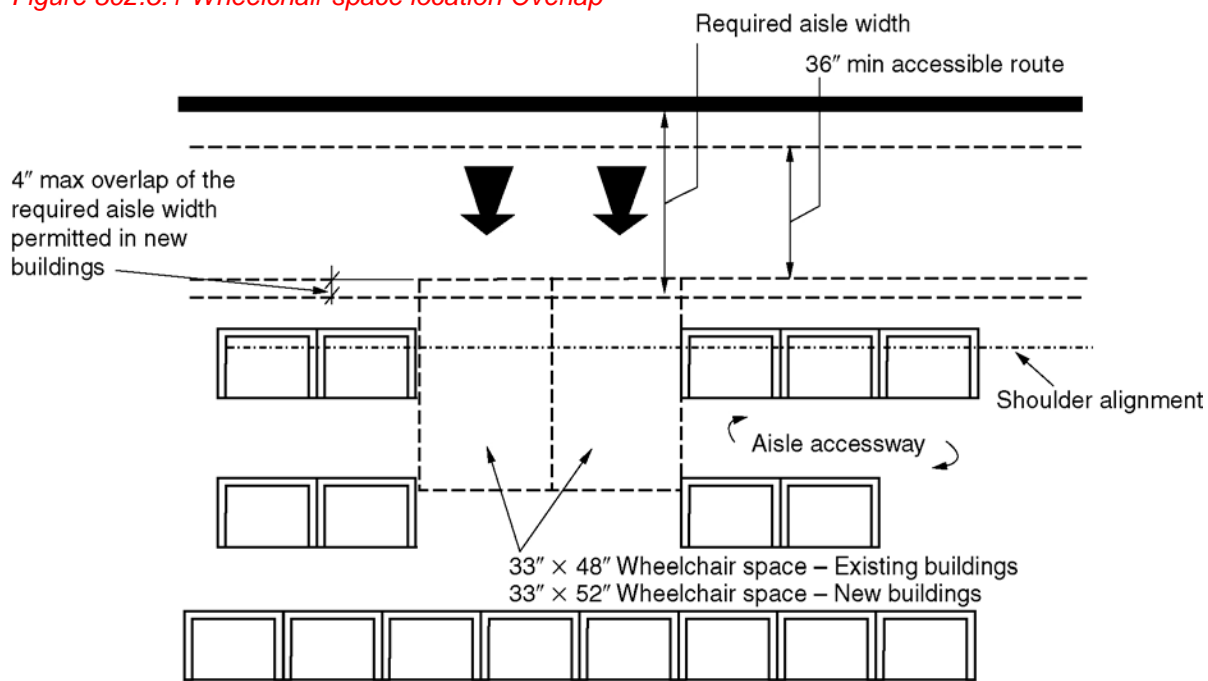
**802.5 Approach.** The wheelchair space shall adjoin an accessible route. The accessible route shall not overlap the wheelchair space.

**802.5.1 Overlap.** A wheelchair space location shall not overlap the required width of an aisle.

**Exception:** In new buildings the depth of **the** wheelchair space shall be permitted to overlap the required aisle width a maximum of 4 inches (100 mm). (3-13D-12) (3-6-12 PC2) (ed.)

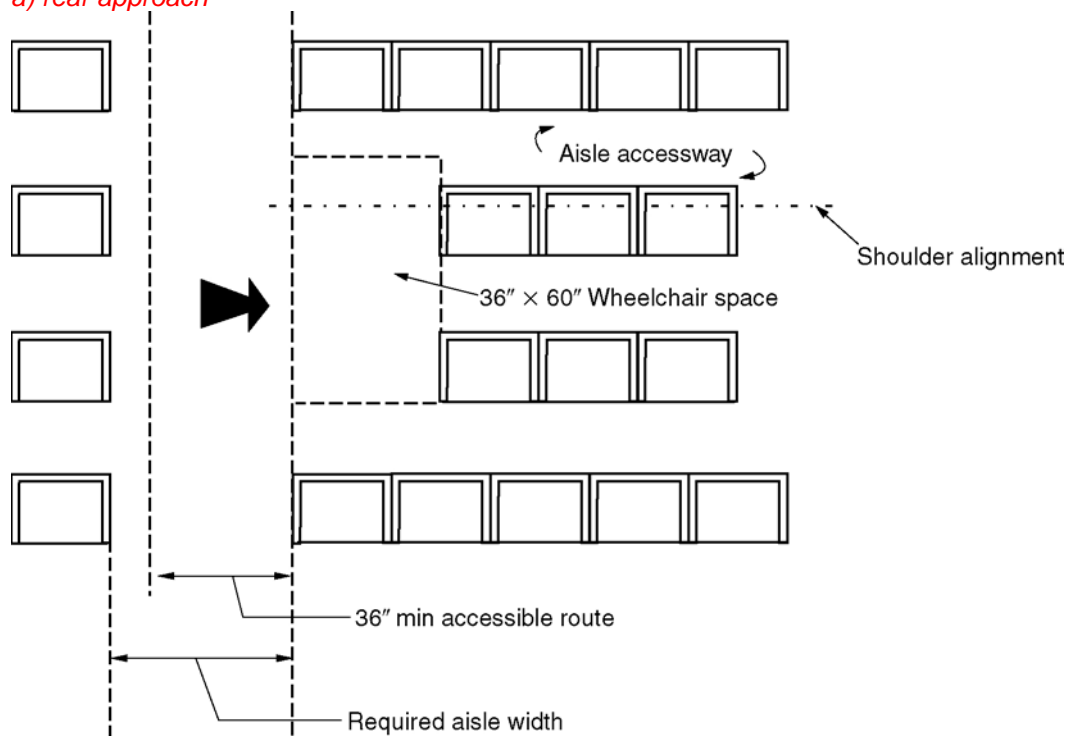


Figure 802.5.1 Wheelchair space location Overlap



(a) REAR APPROACH

a) rear approach



(b) SIDE APPROACH

b) side approach

**802.6 Integration of Wheelchair Space Locations.** Wheelchair space locations shall be an integral part of any seating area.

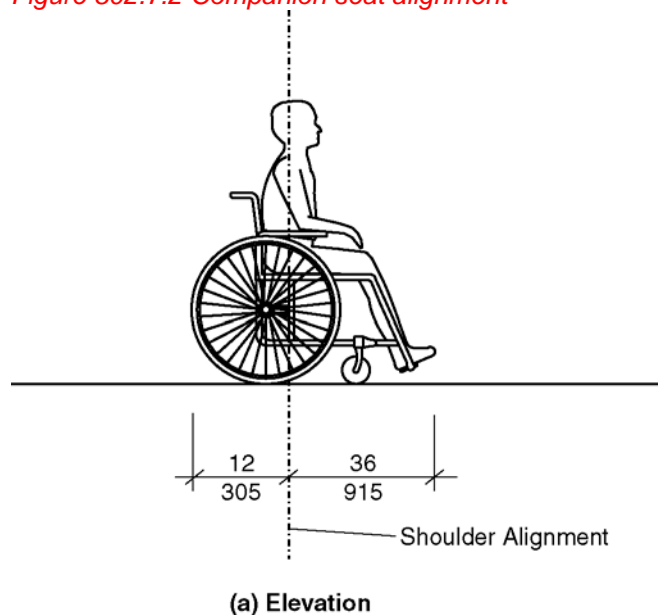
**802.7 Companion Seat.** A companion seat, complying with Section 802.7, shall be provided beside each wheelchair space.

**802.7.1 Companion Seat Type.** The companion seat shall be equivalent in size, quality, comfort and amenities to the seats in the immediate area to the wheelchair space location. Companion seats shall be permitted to be moveable.

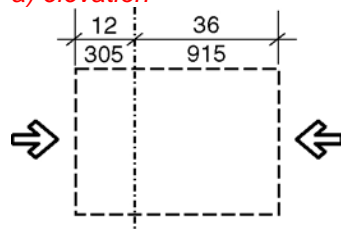
**802.7.2 Companion Seat Alignment.** In row seating, the companion seat shall be located to provide shoulder alignment with the wheelchair space occupant. The floor surface for the companion seat shall be at the same elevation as the wheelchair space floor surface. (3-13E-12)

**EXCEPTION:** Companion seat alignment shall not be required in tiered seating that includes dining surfaces or work surfaces. (8-2-12) (ed.)

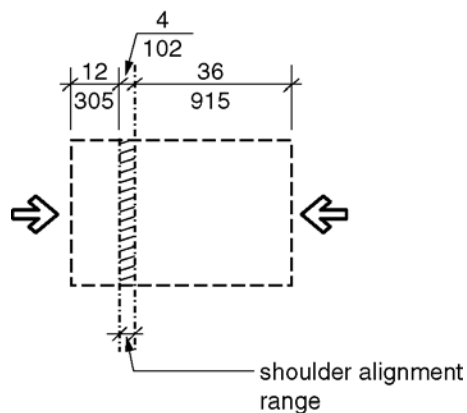
*Figure 802.7.2 Companion seat alignment*



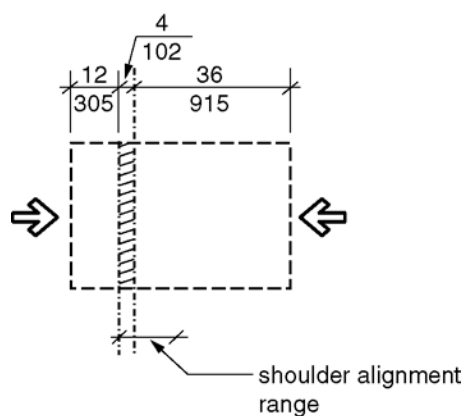
*a) elevation*



*b) Front or rear approach Existing buildings*

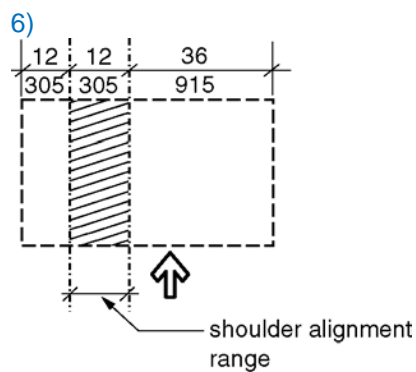


(c) Front or Rear Approach  
New Building



(c) Front or Rear Approach  
New Building

*c) Front or rear approach New buildings*



(d) Side Approach  
Existing Building

*d) Side approach*

*d) Side approach*

**802.7.2.1 New buildings.** In new buildings, the shoulder of the wheelchair occupant is considered to be 36 inches (915 mm) or more from the front or 12 inches (305 mm) or more from the rear of the wheelchair space. (ed.)(3-6-12 PC2)

**802.7.2.2 Existing buildings.** In existing buildings, The shoulder of the wheelchair space occupant is considered to be 36 inches (915 mm) or more from the front or 12 inches (305 mm) or more from the rear of the wheelchair space. (3-6-12 PC2) (ed.)

**802.8 Designated Aisle Seats.** Designated aisle seats shall comply with Section 802.8.

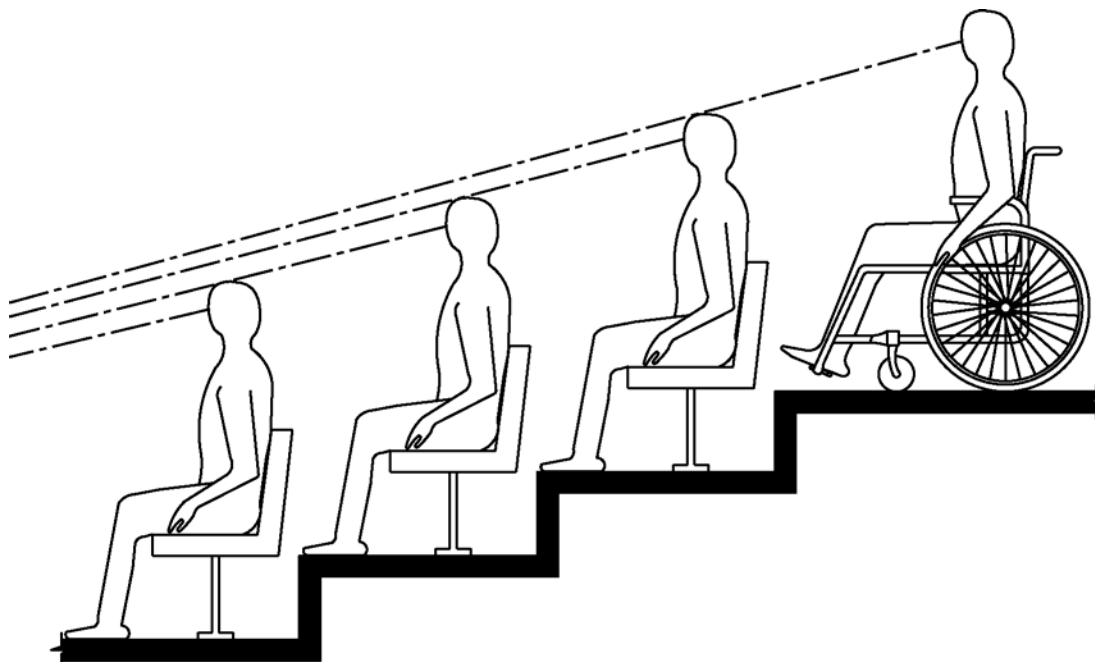
**802.8.1 Armrests.** Where armrests are provided on seating in the immediate area of designated aisle seats, folding or retractable armrests shall be provided on the aisle side of the designated aisle seat.

**802.8.2 Identification.** Each designated aisle seat shall be identified by a sign or marker. (8-1-12)

**802.9 Lines of Sight.** Where spectators are expected to remain seated for purposes of viewing events, spectators in wheelchair space locations shall be provided with a line of sight in accordance with Section 802.9.1. Where spectators in front of the wheelchair space locations will be expected to stand at their seats for purposes of viewing events, spectators in wheelchair space locations shall be provided with a line of sight in accordance with Section 802.9.2.

**802.9.1 Line of Sight over Seated Spectators.** Where spectators are expected to remain seated during events, spectators seated in a wheelchair space shall be provided with lines of sight to the performance area or playing field comparable to that provided to seated spectators in closest proximity to the wheelchair space location. Where seating provides lines of sight over heads, spectators in wheelchair space locations shall be afforded lines of sight complying with Section 802.9.1.1. Where wheelchair space locations provide lines of sight over the shoulder and between heads, spectators in wheelchair space locations shall be afforded lines of sight complying with Section 802.9.1.2.

**802.9.1.1 Lines of Sight over Heads.** Spectators seated in a wheelchair space shall be afforded lines of sight over the heads of seated individuals in the first row in front of the wheelchair space location.



*Figure 802.9.1.1 - Lines of sight over the heads of seated spectators*

**802.9.1.2 Lines of Sight between Heads.** Spectators seated in a wheelchair space shall be afforded lines of sight over the shoulders and between the heads of seated individuals in the first row in front of the wheelchair space location.

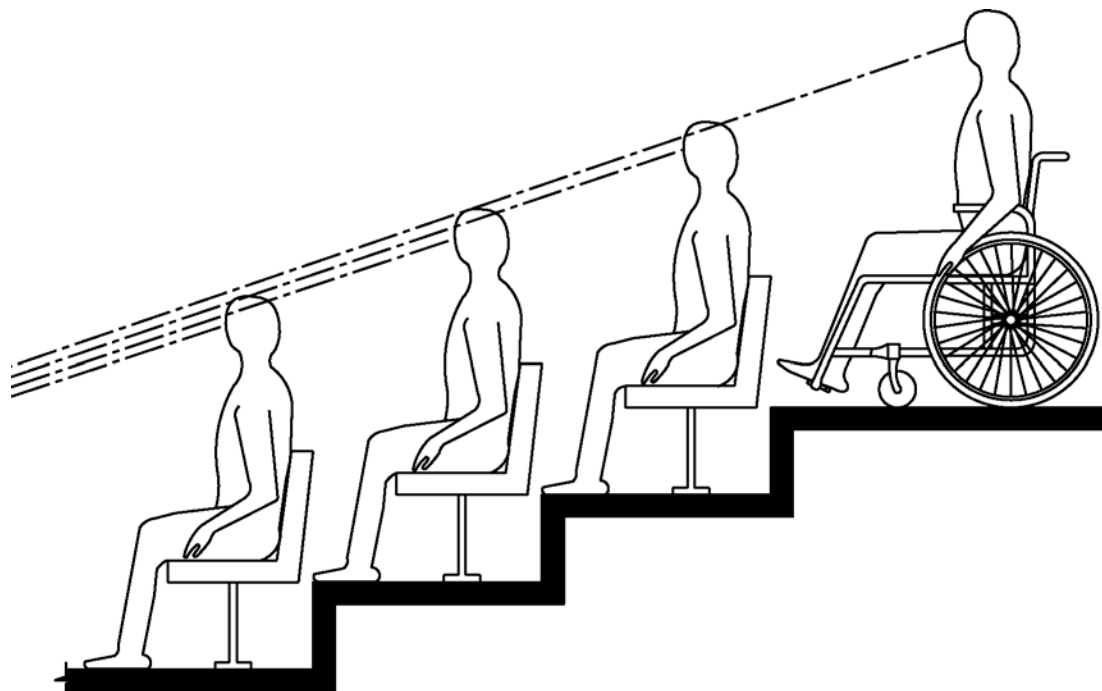


Figure 802.9.1.2 - Lines of sight between the heads of seated spectators

**802.9.2 Line of Sight over Standing Spectators.** Wheelchair spaces required to provide a line of sight over standing spectators shall comply with Section 802.9.2.

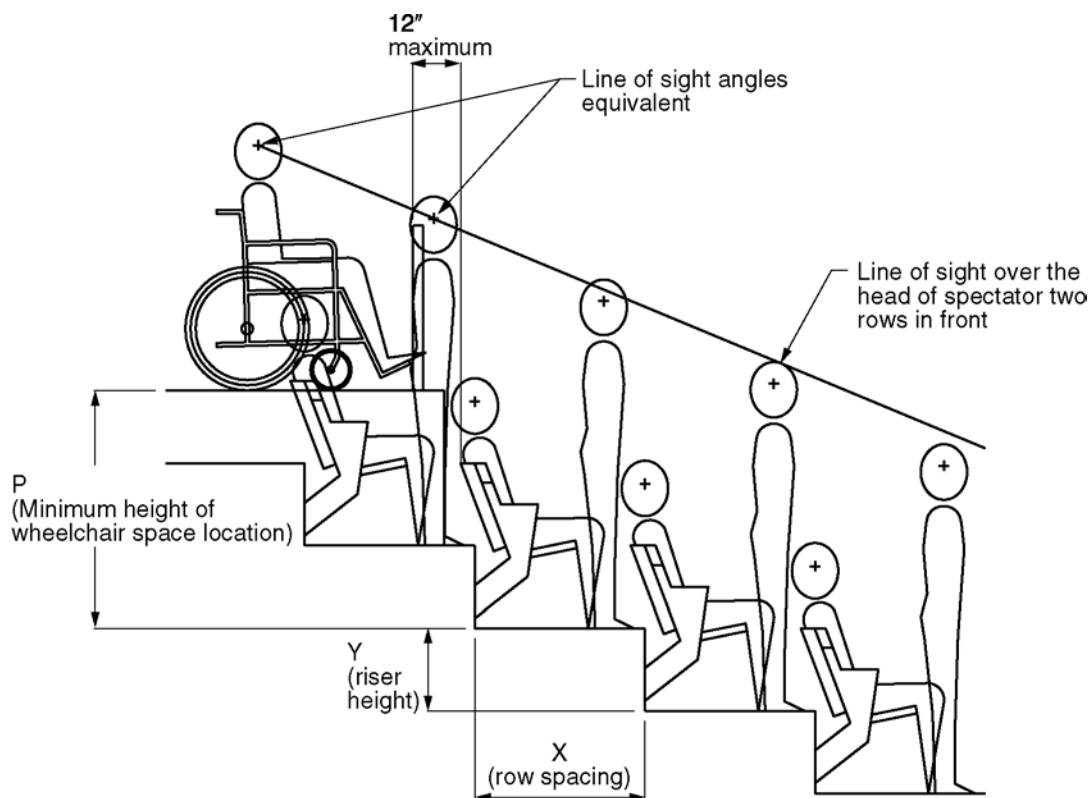


Figure 802.9.2- Lines of sight over standing spectators

**802.9.2.1 Distance from Adjacent Seating.** The front of the wheelchair space in a wheelchair space location shall be 12 inches (305 mm) maximum from the back of the chair or bench in front.

**802.9.2.2 Height.** The height of the floor surface at the wheelchair space location shall comply with Table 802.9.2.2. Interpolations shall be permitted for riser heights that are not listed in the table.

**Table 802.9.2.2  
Required Wheelchair Space Location Elevation Over Standing Spectators**

Riser height	Minimum height of the wheelchair space location based on row spacing <sup>1</sup>		
	Rows less than 33 inches (840 mm) <sup>2</sup>	Rows 33 inches (840 mm) to 44 inches (1120 mm) <sup>2</sup>	Rows over 44 inches (1120 mm) <sup>2</sup>
0 inch (0 mm)	16 inches (405 mm)	16 inches (405 mm)	16 inches (405 mm)
4 inches (100 mm)	22 inches (560 mm)	21 inches (535 mm)	21 inches (535 mm)
8 inches (205 mm)	31 inches (785 mm)	30 inches (760 mm)	28 inches (710 mm)
12 inches (305 mm)	40 inches (1015 mm)	37 inches (940 mm)	35 inches (890 mm)
16 inches (405 mm)	49 inches (1245 mm)	45 inches (1145 mm)	42 inches (1065 mm)
20 inches (510 mm) <sup>3</sup>	58 inches (1475 mm)	53 inches (1345 mm)	49 inches (1245 mm)
24 inches (610 mm)	N/A	61 inches (1550 mm)	56 inches (1420 mm)
28 inches (710 mm) <sup>4</sup>	N/A	69 inches (1750 mm)	63 inches (1600 mm)
32 inches (815 mm)	N/A	N/A	70 inches (1780 mm)
36 inches (915 mm) and higher	N/A	N/A	77 inches (1955 mm)

**Footnotes to Table 802.9.2.2**

<sup>1</sup>The height of the wheelchair space location is the vertical distance from the tread of the row of seats directly in front of the wheelchair space location to the tread of the wheelchair space location.

<sup>2</sup>The row spacing is the back-to-back horizontal distance between the rows of seats in front of the wheelchair space location.

<sup>3</sup>Seating treads less than 33 inches (840 mm) in depth **shall not be** permitted with risers greater than 18 inches (455 mm) in height. (ed.)

<sup>4</sup>Seating treads less than 44 inches (1120 mm) in depth **shall not be** permitted with risers greater than 27 inches (685 mm) in height. (ed.)

**NOTE:** Table 802.9.2.2 is based on providing a spectator in a wheelchair a line of sight over the head of a spectator two rows in front of the wheelchair space location using average anthropometrical data. The table is based on the following calculation:  $[(2X+34)(Y-2.25)/X]+(20.2-Y)$  where Y is the riser height of the rows in front of the wheelchair space location and X is the tread depth of the rows in front of the wheelchair space location. The calculation is based on the front of the wheelchair space location being located 12 inches (305 mm) from the back of the seating tread directly in front and the eye of the standing spectator being set back 8 inches (205 mm) from the riser.

**802.10 Wheelchair Space Dispersion.** The minimum number of wheelchair space locations shall be in accordance with Table 802.10. Wheelchair space locations shall be dispersed in accordance with Sections 802.10.1, 802.10.2 and 802.10.3. In addition, wheelchair space locations shall be dispersed in accordance with Section 802.10.4 in spaces utilized primarily for viewing motion picture projection. Once the required number of wheelchair space locations has been met, further dispersion **shall not be** required. (ed.)

**Table 802.10  
Wheelchair Space Location Dispersion**

Total seating in Assembly Areas	Minimum required number of wheelchair space locations
Up to 150	1
151 to 500	2
501 to 1000	3
1001 to 5,000	3, plus 1 additional space for each 1,000 seats or portions thereof above 1,000
5,001 and over	7, plus 1 additional space for each 2,000 seats or portions thereof above 5,000

**802.10.1 Horizontal Dispersion.** Wheelchair space locations shall be dispersed horizontally to provide viewing options. Where seating encircles the stage or field, in whole or in part, horizontal dispersion shall include the entire seating area. Two wheelchair spaces shall be permitted to be located side-by-side. (8-4-12)

**EXCEPTION:** Horizontal dispersion shall not be required in assembly areas with 300 or fewer seats if the wheelchair space locations are located within the 2<sup>nd</sup> and 3<sup>rd</sup> quartile of the row length. Intermediate aisles shall be included in determining the total row length. If the row length in the 2<sup>nd</sup> and 3<sup>rd</sup> quartile of the row is insufficient to accommodate the required number of companion seats and wheelchair spaces, the additional companion seats and wheelchair spaces shall be permitted to extend into the 1<sup>st</sup> and 4<sup>th</sup> quartile of the row.

**802.10.2 Dispersion for Variety of Distances from the Event.** Wheelchair space locations shall be dispersed at a variety of distances from the event to provide viewing options.

**EXCEPTIONS:**

1. In bleachers, wheelchair space locations provided only in rows at points of entry to bleacher seating shall be permitted.
2. Assembly areas utilized for viewing motion picture projections with 300 seats or less shall not be required to comply with Section 802.10.2.
3. Assembly areas with 300 seats or less other than those utilized for viewing motion picture projections shall not be required to comply with Section 802.10.2 where all wheelchair space locations are within the front 50 percent of the total rows.

**802.10.3 Dispersion by Type.** Where assembly seating has multiple distinct seating areas with amenities that differ from other distinct seating areas, wheelchair space locations shall be provided within each distinct seating area.

**802.10.3.1 Charging Stations.** Where charging stations are provided at wheelchair space locations they shall comply with Section 906. (8-5-12)

**802.10.4 Spaces Utilized Primarily for Viewing Motion Picture Projections.** In spaces utilized primarily for viewing motion picture projections, wheelchair space locations shall comply with Section 802.10.4.

**802.10.4.1 Spaces with Seating on Risers.** Where tiered seating is provided, wheelchair space locations shall be integrated into the tiered seating area on a riser or a cross-aisle. (8-1-12)

**802.10.4.2 Distance from the Screen.** Wheelchair space locations shall be located in accordance with one of the following:

1. Within the rear **60** percent of the seats provided; or
2. Located within the area of an auditorium in which the vertical viewing angles, as measured to the top of the screen, are from the 40th to the 100th percentile of vertical viewing angles for all seats as ranked from the seats in the first row (1st percentile) to seats in the back row (100th percentile). **(8-1-12)**

## **802.11 Stage Lighting for Sign Language Interpreters (8-6-12 PC1)**

**802.11.1 General.** Sign language interpreter stations shall comply with Section 802.11. (8-6-12 PC1)

**802.11.2 Area.** A sign language interpreter station shall provide a level and clear floor of with a minimum size of 24 inches (610 mm) deep and 36 inches (915 mm) wide that is located to provide a direct line of sight from the seating area identified in Section 802.11.3. (8-6-12 PC1.1)

**802.11.3 Location.** Sign language interpreter stations shall be located so that seating within an arc from the station and measured to the left and to the right 60 degrees within 65 feet (19.8 m) horizontal distance from the station is provided with sightlines providing a view of sign language station from a height of 36 inches (915 mm) to 72 (1830 mm) inches above the floor of the station. ~~The vertical viewing angle from the person in the seat to the interpreter station shall not exceed 30 degrees measured to the front and center of the floor and center of the floor of the sign language station.~~  
(8-6-12 PC1.1) (8.6.12/1.1-PC1.1 Agenda 42.1)

**802.11.4 Illumination:** The sign language interpreter station shall have lighting facilities capable of providing 10 footcandles (108 lux) of illuminance while signing is underway measured at the center of the floor of the sign language station at a height of 48 inches (1220 mm) above the floor. (8-6-12 PC1.1)

**802.11.5 Backdrop.** When a sign language interpreter station is located with a permanent wall less than 10 feet (3050 mm) ~~in front of a permanent wall~~ behind the sign language interpreter station, the permanent wall and to a height of 96 inches (2440 mm) from the finish floor shall be considered as a backdrop. The backdrop shall provide a flat, smooth surface with a monochromatic, low-luster finish treatment. . (8-6-12 PC1.1) (8.6.12/1.1-PC1.1 Agenda 42.1)

**Exception:** The wall ~~shall not be~~ required to comply with Section 802.11.4 where a backdrop with a monochromatic, low luster finish treatment is provided. (8-6-12 PC1.1) (ed.)

## **803 Dressing, Fitting, and Locker Rooms**

**803.1 General.** ~~Accessible~~ dressing, fitting, and locker rooms shall comply with Section 803. (ed.)

**803.2 Turning Space.** A turning space complying with Section 304 shall be provided within the room.

**803.3 Door Swing.** Doors shall not swing into the room unless a clear floor space complying with Section 305.3 is provided within the room, beyond the arc of the door swing.

**803.4 Benches.** A bench complying with Section 903 shall be provided within the room.

**803.5 Coat Hooks and Shelves.** ~~Accessible~~ coat hooks provided within the room shall accommodate a forward reach or side reach complying with Section 308. Where provided, a shelf shall be 40 inches (1015 mm) minimum and 48 inches (1220 mm) maximum above the floor. (ed.)

## **804 Kitchens and Kitchenettes**

**804.1 General.** ~~Accessible~~ kitchens and kitchenettes shall comply with Section 804. (ed.)



**804.2 Clearance.** Where a pass-through kitchen is provided, clearances shall comply with Section 804.2.1. Where a U-shaped kitchen is provided, clearances shall comply with Section 804.2.2. Kitchens where a cook top or conventional range is not provided shall comply with Section 804.2.3. (8-13-12)

**804.2.1 Pass-through Kitchens.** In pass-through kitchens where counters, appliances or cabinets are on two opposing sides, or where counters, appliances or cabinets are opposite a parallel wall, clearance between all opposing base cabinets, counter tops, appliances, or walls within kitchen work areas shall be 40 inches (1015 mm) minimum. Pass-through kitchens shall have two entries.

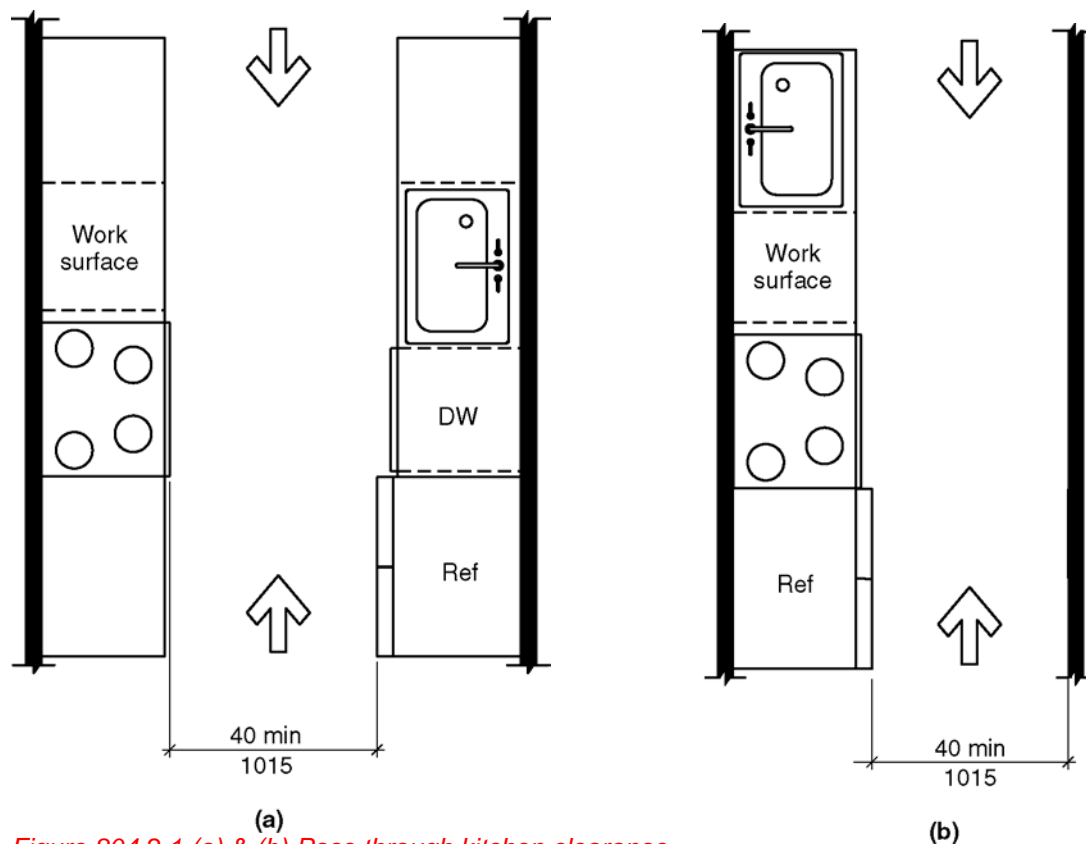


Figure 804.2.1 (a) & (b) Pass through kitchen clearance

**804.2.2 U-Shaped Kitchens.** In kitchens enclosed on three contiguous sides, clearance between all opposing base cabinets, countertops, appliances, or walls within kitchen work areas shall be 60 inches (1525 mm) minimum. (3-6E-12 PC4 through PC6) .(3-6-12 PC2.1)

**EXCEPTION:** U-shaped kitchens with an island shall be permitted to comply with Section 804.2.1. (8-9-12)

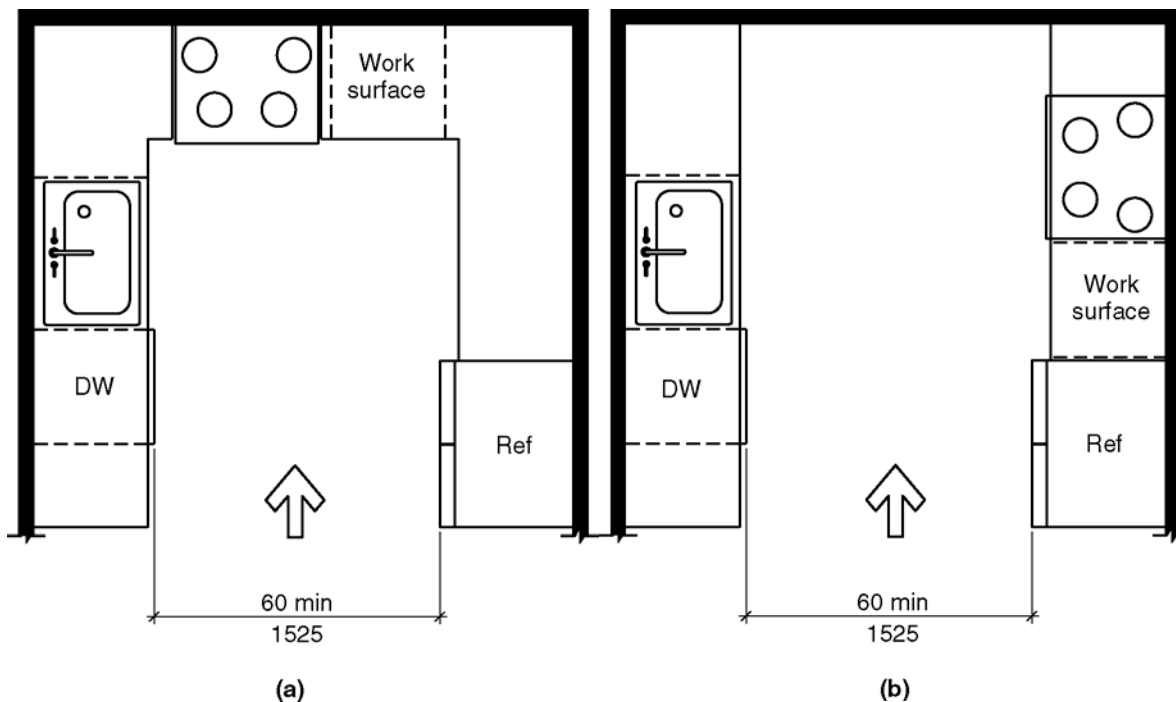
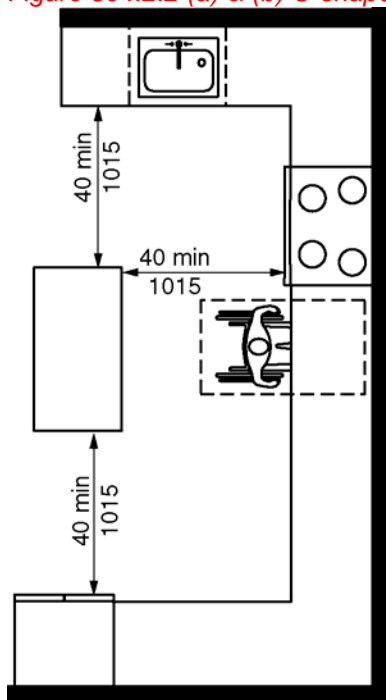


Figure 804.2.2 (a) & (b) U-shaped kitchen clearance



c) exception

**804.2.3 Spaces where a cook top or conventional range is not provided.** In a kitchen space where a cooktop or conventional range is not provided, clearance between all opposing base cabinets, counter tops, appliances and walls within kitchen work areas shall be 40-inch (1015 mm) minimum. (8-13-12) (ed.)

**804.3 Work Surface.** At least one accessible work surface, 30 inches minimum in length shall be provided in accordance with Section 902. The work surface shall be located in accordance with Section 804.5.5.2 or 804.5.5.3. (8-10-12) (8-11-12)

**EXCEPTION:** Spaces that do not provide a cooktop or conventional range shall not be required to provide an accessible work surface.

**804.4 Sinks.** The sink shall comply with Section 606.

**804.5 Appliances.** Where provided, kitchen appliances shall comply with Section 804.5.

**804.5.1 Clear Floor Space.** A clear floor space complying with Section 305 shall be provided at each kitchen appliance.

**804.5.2 Operable Parts.** All appliance controls shall comply with Section 309.

**EXCEPTIONS:**

1. Appliance doors and door latching devices shall not be required to comply with Section 309.4.
2. Bottom-hinged appliance doors, when in the open position, shall not be required to comply with Section 309.3.

**804.5.3 Dishwasher.** A clear floor space positioned adjacent to the dishwasher door, shall be provided. The dishwasher door in the open position shall not obstruct the clear floor space for the dishwasher or an adjacent sink.

**804.5.4 Cooktop.** Cooktops shall comply with Section 804.5.4.

**804.5.4.1 Approach.** A clear floor space, positioned for a parallel or forward approach to the cooktop, shall be provided.

**804.5.4.2 Forward approach.** Where the clear floor space is positioned for a forward approach, knee and toe clearance complying with Section 306 shall be provided. The underside of the cooktop shall be insulated or otherwise configured to prevent burns, abrasions, or electrical shock.

**804.5.4.3 Parallel approach.** Where the clear floor space is positioned for a parallel approach, the clear floor space shall be centered on the appliance.

**804.5.4.4 Controls.** The location of controls shall not require reaching across burners.

**804.5.5 Oven.** Ovens shall comply with Section 804.5.5.

**804.5.5.1 Clear floor space.** A clear floor space shall be provided. The oven door in the open position shall not obstruct the clear floor space for the oven.

**804.5.5.2 Side-Hinged Door Ovens.** Side-hinged door ovens shall have a work surface complying with Section 804.3 positioned adjacent to the latch side of the oven door.

**804.5.5.3 Bottom-Hinged Door Ovens.** Bottom-hinged door ovens shall have a work surface complying with Section 804.3 positioned adjacent to one side of the door.

**804.5.5.4 Controls.** The location of controls shall not require reaching across burners.

**804.5.6 Refrigerator/Freezer.** Combination refrigerators and freezers shall have at least 50 percent of the freezer compartment shelves, including the bottom of the freezer, 54 inches (1370 mm) maximum above the floor when the shelves are installed at the maximum heights possible in the compartment. A clear floor space, positioned for a parallel approach to the refrigerator/freezer, shall be provided. The

centerline of the clear floor space shall be offset 24 inches (610 mm) maximum from the centerline of the appliance.

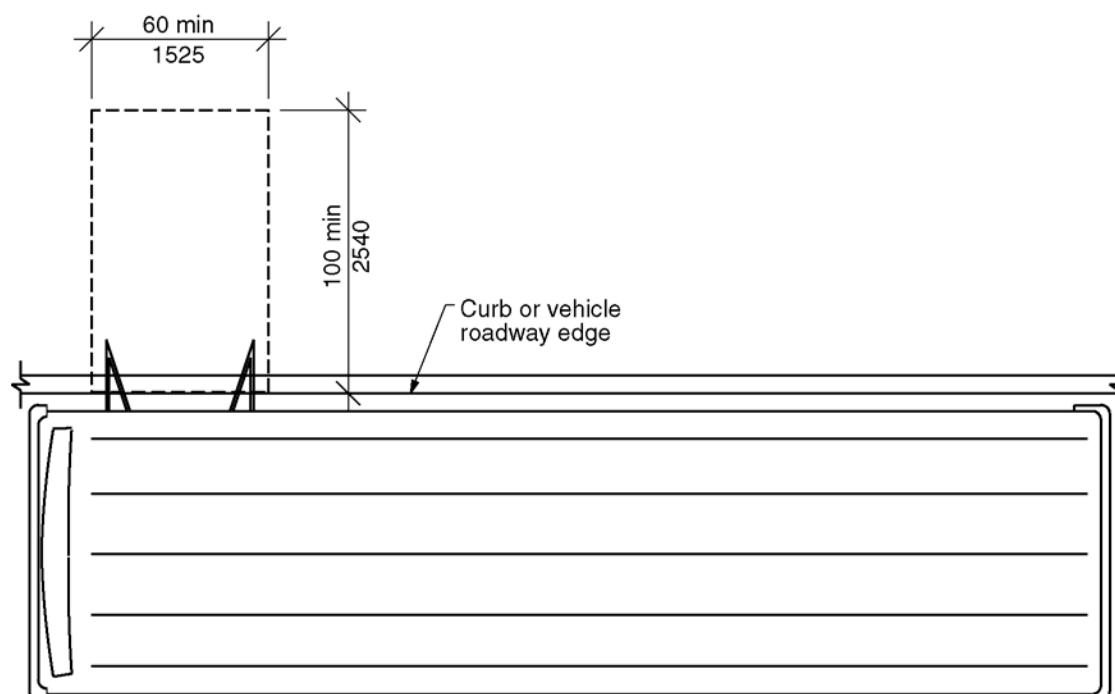
## 805 Transportation Facilities

**805.1 General.** Transportation facilities shall comply with Section 805.

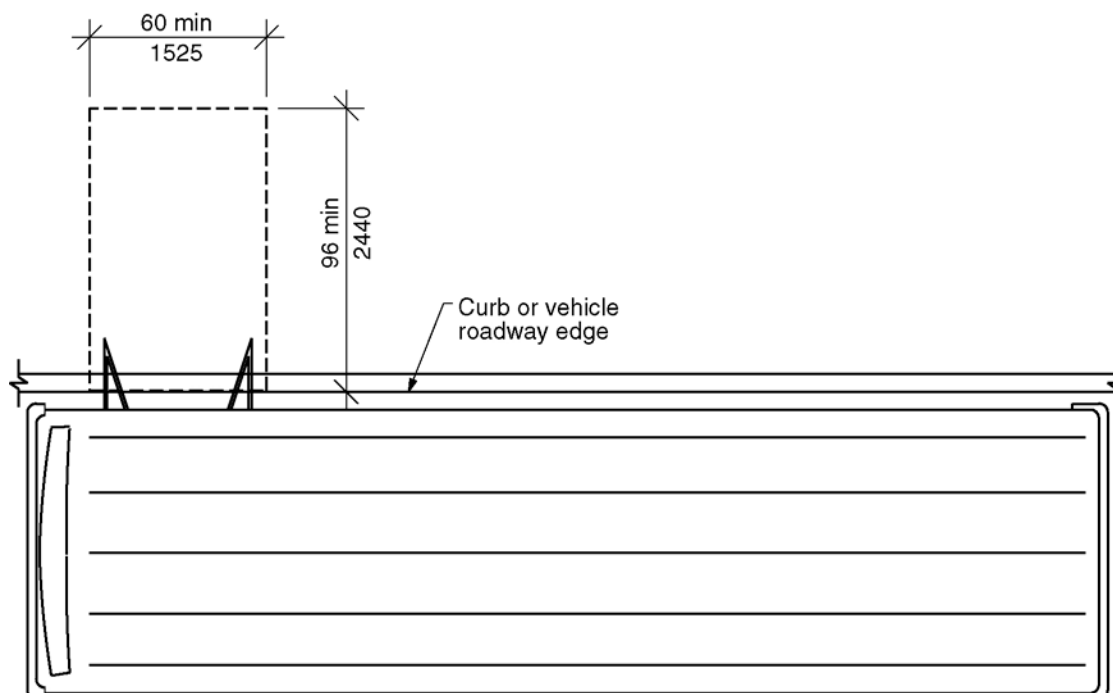
**805.2 Bus Boarding and Alighting Areas.** Bus boarding and alighting areas shall comply with Section 805.2.

**805.2.1 Surface.** Bus stop boarding and alighting areas shall have a firm, stable surface.

**805.2.2 Dimensions.**



*Figure 805.2.2(a) - Size of bus boarding and alighting area – New buildings*



*Figure 805.2.2(b) - Size of bus boarding and alighting area- Existing buildings*

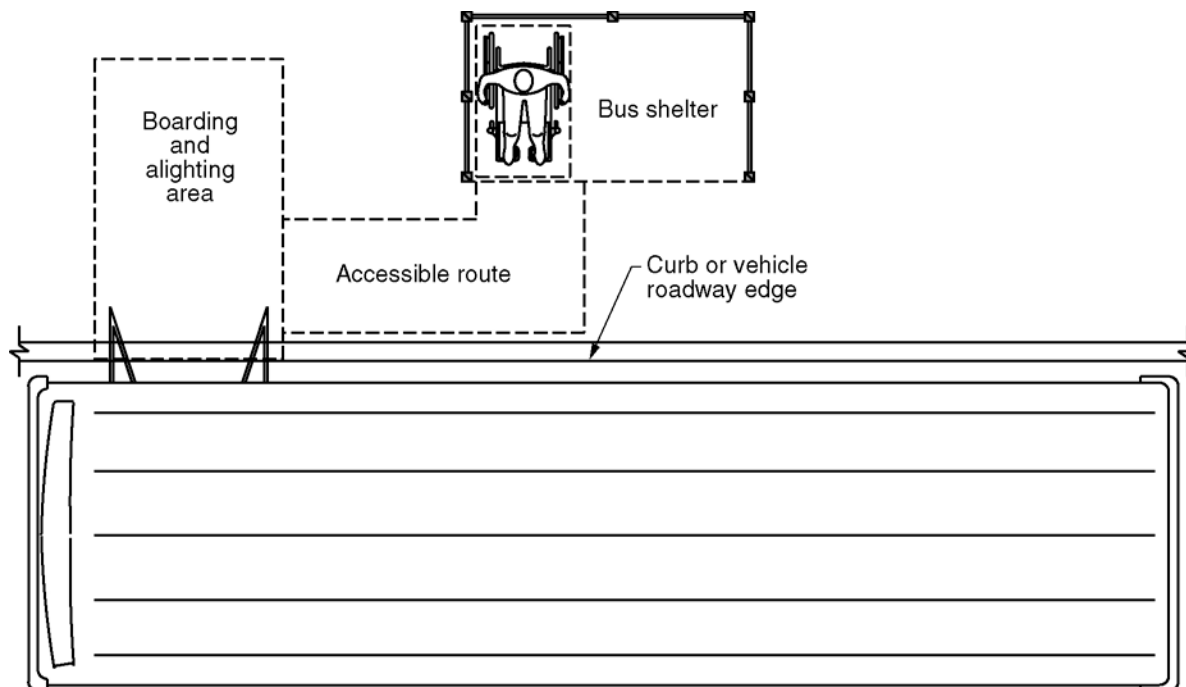
**805.2.2.1 New buildings and sites.** In new buildings and sites, bus stop boarding and alighting areas shall have a 100-inch (2540 mm) minimum clear length, measured perpendicular to the curb or vehicle roadway edge, and a 60-inch (1525 mm) minimum clear width, measured parallel to the vehicle roadway. (3-13F-12) .(3-6-12 PC2)

**805.2.2.2 Existing buildings and sites.** In existing buildings and sites, bus stop boarding and alighting areas shall have a 96 -inch (2540 mm) minimum clear length, measured perpendicular to the curb or vehicle roadway edge, and a 60-inch (1525 mm) minimum clear width, measured parallel to the vehicle roadway.(3-6-12 PC2)

**805.2.3 Slope.** The slope of the bus stop boarding and alighting area parallel to the vehicle roadway shall be the same as the roadway, to the maximum extent practicable. The slope of the bus stop boarding and alighting area perpendicular to the vehicle roadway shall be 1:48 maximum.

**805.2.4 Connection.** Bus stop boarding and alighting areas shall be connected to streets, sidewalks, or pedestrian paths by an accessible route complying with Section 402.

**805.3 Bus Shelters.** Bus shelters shall provide a minimum clear floor space complying with Section 305 entirely within the shelter. Bus shelters shall be connected by an accessible route complying with Section 402 to a boarding and alighting area complying with Section 805.2.



*Figure 805.3 – Bus shelters*

**805.4 Bus Signs.** Bus route identification signs shall have visual characters complying with Sections 703.2.2, 703.2.3, and 703.2.5 through 703.2.8. In addition, bus route identification numbers shall be visual characters complying with Section 703.2.4.

**EXCEPTION:** Bus schedules, timetables and maps that are posted at the bus stop or bus bay shall not be required to comply with Section 805.4.

**805.5 Rail Platforms.** Rail platforms shall comply with Section 805.5.

**805.5.1 Slope.** Rail platforms shall not exceed a slope of 1:48 in all directions.

**EXCEPTION:** Where platforms serve vehicles operating on existing track or track laid in existing roadway, the slope of the platform parallel to the track shall be permitted to be equal to the slope (grade) of the roadway or existing track.

**805.5.2 Detectable Warnings.** Platform boarding edges not protected by platform screens or guards shall have a detectable warning complying with Section 705.

**805.6 Rail Station Signs.** Rail station signs shall comply with Section 805.6.

**EXCEPTION:** Signs shall not be required to comply with Sections 805.6.1 and 805.6.2 where audible signs are remotely transmitted to hand-held receivers, or are user- or proximity-actuated.

**805.6.1 Entrances.** Where signs identify a station or a station entrance, at least one sign with raised characters and braille complying with Sections 703.3 and 703.4 shall be provided at each entrance.

**805.6.2 Routes and Destinations.** Lists of stations, routes and destinations served by the station that are located on boarding areas, platforms, or mezzanines shall have visual characters complying with Section 703.2. A minimum of one sign with raised characters and braille complying with Sections 703.3 and 703.4 shall be provided on each platform or boarding area to identify the specific station.

**EXCEPTION:** Where sign space is limited, characters shall not be required to exceed 3 inches

(76 mm) in height.

**805.6.3 Station Names.** Stations covered by this section shall have identification signs with visual characters complying with Section 703.2. The signs shall be clearly visible and within the sight lines of a standing or sitting passenger from within the vehicle on both sides when not obstructed by another vehicle.

**805.7 Public Address Systems.** Where public address systems convey audible information to the public, the same or equivalent information shall be provided in a visual format.

**805.8 Clocks.** Where clocks are provided for use by the public, the clock face shall be uncluttered so that its elements are clearly visible. Hands, numerals and digits shall contrast with the background either light-on-dark or dark-on-light. Where clocks are installed overhead, numerals and digits shall be visual characters complying with Section 703.2.

**805.9 Escalators.** Where provided, escalators shall have a 32-inch (815mm) minimum clear width, and shall comply with Requirements 6.1.3.5.6 - Step Demarcations, and 6.1.3.6.5 - Flat Steps of ASME A17.1/CSA B44 listed in [Section 106.2.9](#).

**EXCEPTION:** Existing escalators shall not be required to comply with Section 805.9.

**805.10 Track Crossings.** Where a circulation path crosses tracks, it shall comply with [Section 402](#) and shall have a detectable warning complying with [Section 705](#)-(4-44-12)

**EXCEPTION:** Openings for wheel flanges shall be permitted to be 2<sup>1</sup>/<sub>2</sub> inches (64 mm) maximum.



*Figure 805.10 – Track crossing*

## 806 Holding Cells and Housing Cells

**806.1 General.** Holding cells and housing cells shall comply with Section 806.

**806.2 Features for People Using Wheelchairs or Other Mobility Aids.** Cells required to have features for people using wheelchairs or other mobility aids shall comply with Section 806.2.

**806.2.1 Turning Space.** Turning space complying with Section 304 shall be provided within the cell.

**806.2.2 Benches.** Where benches are provided, at least one bench shall comply with Section 903.

**806.2.3 Beds.** Where beds are provided, clear floor space complying with Section 305 shall be provided on at least one side of the bed. The clear floor space shall be positioned for parallel approach to the side of the bed.

**806.2.4 Toilet and Bathing Facilities.** Toilet facilities or bathing facilities provided as part of a cell shall comply with Section 603.

**806.3 Communication Features.** Cells required to have communication features shall comply with Section 806.3.

**806.3.1 Alarms.** Where audible emergency alarm systems are provided to serve the occupants of cells,

visible alarms complying with Section 702 shall be provided.

**EXCEPTION:** In cells where inmates or detainees are not allowed independent means of egress, visible alarms shall not be required.

**806.3.2 Telephones.** Where provided, telephones within cells shall have volume controls complying with Section 704.3.

## **807 Courtrooms**

**807.1 General.** Courtrooms shall comply with Section 807.

**807.2 Turning Space.** Where provided, each area that is raised or depressed shall provide a turning space complying with Section 304.

**EXCEPTION:** Levels of jury boxes not required to ~~contain wheelchair spaces~~ shall not be required to comply ~~this section~~. (ed.)

**807.3 Clear Floor Space.** Within the defined area of each jury box and witness stand, a clear floor space complying with Section 305 shall be provided.

**EXCEPTION:** In alterations, wheelchair spaces shall not be required to be located within the defined area of raised jury boxes or witness stands and shall be permitted to be located outside these spaces where ramps or platform lifts restrict or project into the means of egress required by the administrative authority. (ed.)

**807.4 Courtroom Stations.** Judges' benches, clerks' stations, bailiffs' stations, deputy clerks' stations, court reporters' stations and litigants' and counsel stations shall comply with Section 902.

**807.5 Gallery seating.** Gallery seating shall comply with Section 802.

## **808 Enhanced Acoustics for Classrooms**

**808.1 General.** Classrooms not exceeding 20,000 cubic feet (565 m<sup>3</sup>) and required to provide enhanced acoustics shall comply with Section 808. (8-15-12 PC5.1)

**808.2 Reverberation Time.** Classroom reverberation times shall comply with either Section 808.2.1 or Section 808.2.2, depending on the size of the room. (8-15-12 PC4 and PC5)

**808.2.1 Performance Method.** For each of the octave frequency bands with center frequencies of 500, 1000, and 2000 Hz, the Reverberation Time (T<sub>60</sub>) shall not exceed the times specified below:

1. 0.6 seconds in classrooms with volumes up to and including 10,000 cubic feet (285 m<sup>3</sup>).
2. 0.7 seconds in classrooms with volumes of more than 10,000 cubic feet (285 m<sup>3</sup>), but less than 20,000 cubic feet (566 m<sup>3</sup>).

Reverberation times shall apply to fully-furnished, unoccupied classrooms. Reverberation times shall be field-verified via measurements made in accordance with ASTM E2235-04(2012) "Standard Test Method for Determination of Decay Rates for Use in Sound Insulation Test Methods" over a minimum 20 dB decay in each octave frequency band as listed in Section 106.2.15. (8-15-12 PC4 and PC5)

**808.2.2 Prescriptive Method.** The Noise reduction coefficient (NRC) ratings for floor, wall and ceiling surface finishes shall conform to the following equations:



For a classroom with a volume less than or equal to 10,000 cubic feet (285 cubic meters):

$$(NRC_{\text{Floor}} \times S_{\text{Floor}}) + (NRC_{\text{Ceiling}} \times S_{\text{Ceiling}}) + (NRC_{\text{Wall}} \times S_{\text{Wall}}) \geq \text{Volume}/12$$

For a classroom with a volume between 10,000 cubic feet (285 cubic meters) and 20,000 cubic feet (565 cubic meters):

$$(NRC_{\text{Floor}} \times S_{\text{Floor}}) + (NRC_{\text{Ceiling}} \times S_{\text{Ceiling}}) + (NRC_{\text{Wall}} \times S_{\text{Wall}}) \geq \text{Volume}/14$$

Where:

$NRC_{\text{Floor}}$  = NRC rating of the floor finish material

$S_{\text{Floor}}$  = floor area in square feet

$NRC_{\text{Ceiling}}$  = NRC rating of the ceiling finish material

$S_{\text{Ceiling}}$  = ceiling area in square feet

$NRC_{\text{Wall}}$  = NRC rating of the wall acoustical treatment

$S_{\text{Wall}}$  = wall treatment area in square feet

Volume = room volume in cubic feet

Where a floor, ceiling or wall has multiple surface finishes, the NRC x S product for each surface finish shall be added to the left side of the equation. (8-15-12 PC5)

**808.3 Ambient Sound Level.** Classroom ambient sound levels shall comply with Sections 808.3.1 and 808.3.2. Ambient sound levels from sound sources outside and inside the classroom shall be evaluated individually. The greatest one-hour averaged sound levels shall be evaluated at the loudest usable location in the room at a height of 36 inches (915 mm) to 42 inches (1065 mm) above the floor and no closer than 36 inches (915 mm) from any wall, window, or object. The ambient sound level limits shall apply to fully-furnished, unoccupied classrooms, and with only permanent HVAC, electrical and plumbing systems functioning. Classroom equipment, including, but not limited to, computers, printers, fish tank pumps shall be turned off during these measurements. (8-15-12 PC5)

**808.3.1 Sound Sources Outside of the Classroom.** Classroom ambient sound levels shall not exceed 35 dBA and 55 dBC due to intruding noise from sound sources outside of the classroom, whether from the exterior or from other interior spaces. (8-15-12 PC5)

**808.3.2 Sound Sources Inside the Classroom.** Classroom ambient sound levels shall not exceed 35 dBA and 55 dBC for noise from sound sources inside the classroom. (8-15-12 PC5)

## Chapter 9. Furnishings and Equipment

9-1-12 PC1

### 901 General

**901.1 Scope.** Furnishings and equipment required to be accessible by the scoping provisions adopted by the administrative authority shall comply with the applicable provisions of Chapter 9. (9-1-12)

### 902 Dining Surfaces and Work Surfaces

**902.1 General.** Accessible dining surfaces and work surfaces shall comply with Section 902.

**EXCEPTION:** Dining surfaces and work surfaces primarily for children's use shall be permitted to comply with Section 902.5.

**902.2 Clear Floor Space.** A clear floor space complying with Section 305, positioned for a forward approach, shall be provided. Knee and toe clearance complying with Section 306 shall be provided.

#### EXCEPTIONS:

1. At dining surfaces 12 inches (305 mm) or less in depth, knee and toe space shall not be required to extend beneath the surface beyond the depth of the drink surface provided.
2. Dining surfaces that are 15 inches (380 mm) minimum and 24 inches (610 mm) maximum in height are permitted to have a clear floor space complying with Section 305 positioned for a parallel approach.

**902.3 Exposed Surfaces.** There shall be no sharp or abrasive surfaces under the exposed portions of dining surfaces and work surfaces.

**902.4 Height.** The tops of dining surfaces and work surfaces shall be 28 inches (710 mm) minimum and 34 inches (865 mm) maximum in height above the floor.

**902.5 Dining Surfaces and Work Surfaces for Children's Use.** Accessible dining surfaces and work surfaces primarily for children's use shall comply with Section 902.5.

**EXCEPTION:** Dining surfaces and work surfaces used primarily by children ages 5 and younger shall not be required to comply with Section 902.5 where a clear floor space complying with Section 305 is provided and is positioned for a parallel approach.

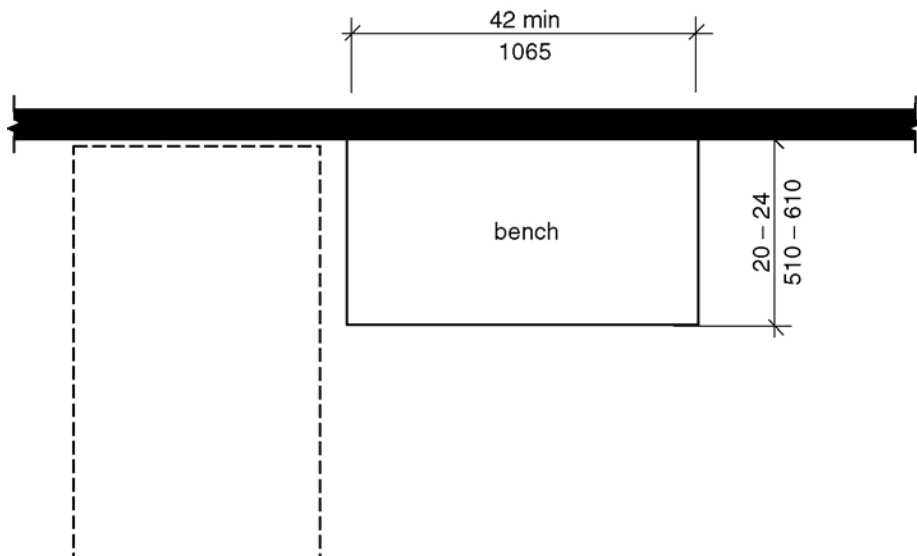
**902.5.1 Clear Floor Space.** A clear floor space complying with Section 305, positioned for forward approach, shall be provided. Knee and toe clearance complying with Section 306 shall be provided.

**EXCEPTION:** A knee clearance of 24 inches (610 mm) minimum above the floor shall be permitted.

**902.5.2 Height.** The tops of tables and counters shall be 26 inches (660 mm) minimum and 30 inches (760 mm) maximum above the floor.

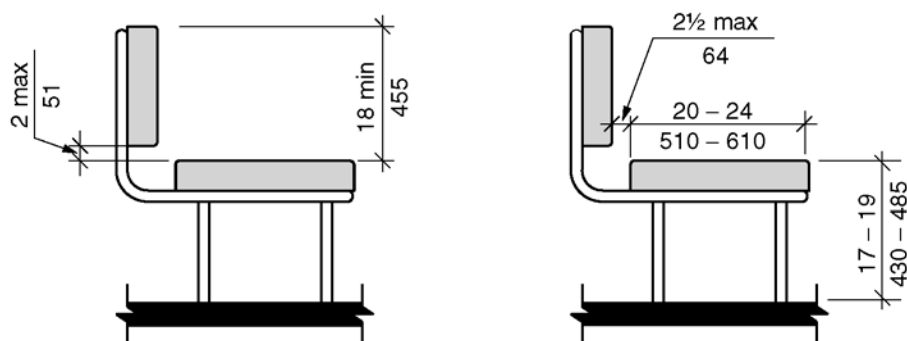
### 903 Benches

**903.1 General.** Accessible benches shall comply with Section 903. (ed.)



(a) Bench Size and Options for Clear Floor Space

*Figure 903 a) Benches – bench size and options for clear floor space*



(b) Bench Back Support and Seat Height

*b) Benches – bench back support and seat height*

**903.2 Clear Floor Space.** A clear floor space complying with Section 305, positioned at the end of the bench seat and parallel to the short axis of the bench shall be provided. (9-4-12)

**903.3 Size.** Benches shall have seats 42 inches (1065 mm) minimum in length, and 20 inches (510 mm) minimum and 24 inches (610 mm) maximum in depth.

**903.4 Back Support.** The bench shall provide for back support or shall be affixed to a wall. Back support shall be 42 inches (1065 mm) minimum in length and shall extend from a point 2 inches (51 mm) maximum above the seat surface to a point 18 inches (455 mm) minimum above the seat surface. Back support shall be 2½ inches (64 mm) maximum from the rear edge of the seat measured horizontally.

**903.5 Height.** The top of the bench seat shall be 17 inches (430 mm) minimum and 19 inches (485 mm) maximum above the floor, measured to the top of the seat.

**EXCEPTION:** Benches primarily for children's use shall be permitted to be 11 inches (280 mm) minimum and 17 inches (430 mm) maximum above the floor, measured to the top of the seat.

**903.6 Structural Strength.** Allowable stresses shall not be exceeded for materials used where a vertical or horizontal force of 250 pounds (1112 N) is applied at any point on the seat, fastener mounting device, or supporting structure.

**903.7 Wet Locations.** Where provided in wet locations the surface of the seat shall be slip resistant and shall not accumulate water.

## 904 Sales and Service Counters

**904.1 General.** Accessible sales and service counters and windows shall comply with Section 904 as applicable.

**EXCEPTION:** Drive up only sales or service counters and windows shall not be required to comply with Section 904.

**904.2 Approach.** All portions of counters required to be accessible shall be located adjacent to a walking surface complying with Section 403.

**904.3 Sales and Service Counters and Windows.** Sales and service counters and windows shall comply with Sections 904.3.1 and either 904.3.2 or Section 904.3.3. . Where counters are provided, the accessible portion of the countertop shall extend the same depth as the public portion of the sales and service countertop provided for standing customers. (9-7-12) (9-9-12)(9-10-12) (9-10-12 PC3)

**EXCEPTION:** In alterations, when the provision of a counter complying with Section 904.4 would result in a reduction of the number of existing counters at work stations or a reduction of the number of existing mail boxes, the counter shall be permitted to have a portion which is 24 inches (610 mm) long minimum complying with Section 904.4.1 provided that the required clear floor space is centered on the accessible length of the counter. (9-6-12)

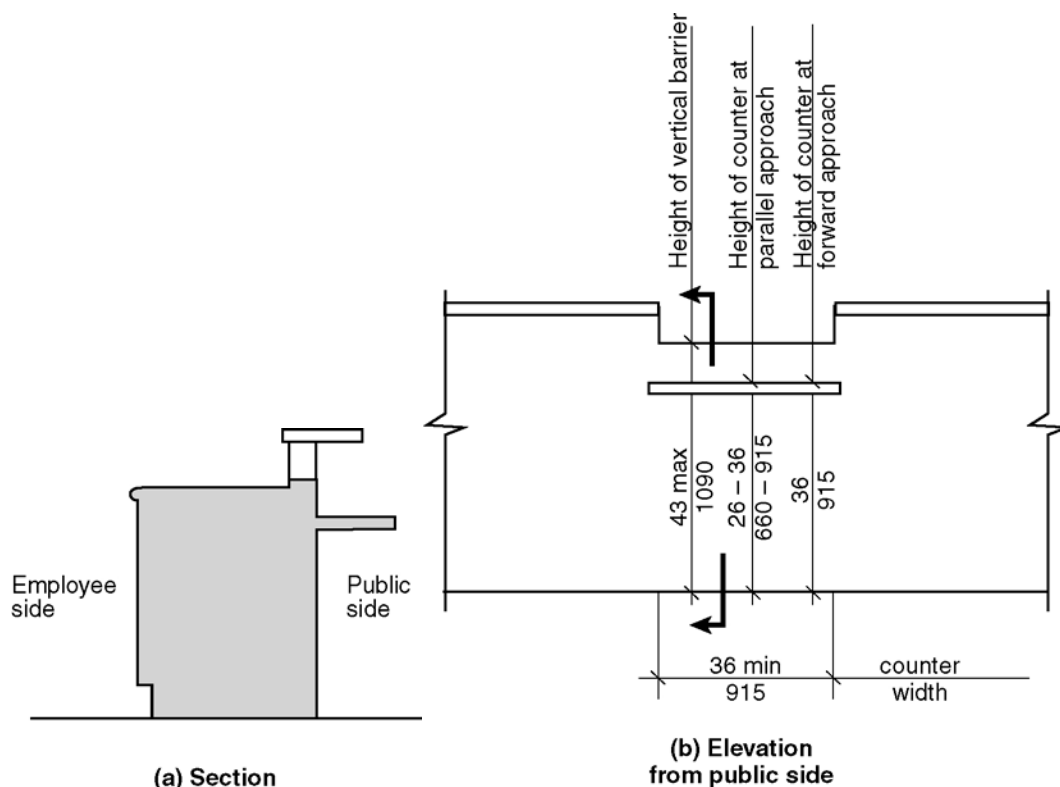


Figure 904.3 – Sales and service counters

**904.3.1 Vertical Barriers.** At service windows or service counters, any vertical barrier between service personnel and customers shall be at a height of 43 inches (1090 mm) maximum above the floor. (9-10-12)

**Exception:** Transparent security glazing shall be permitted above the 43 inches (1090 mm) maximum height. (9-10-12)

**904.3.2 Parallel Approach.** A portion of the public use side of the counter surface 36 inches (915 mm) minimum in length and 26 inches (660 mm) minimum to 36 inches (915 mm) maximum in height above the floor shall be provided. A clear floor space complying with Section 305, positioned for a parallel approach adjacent to the accessible counter, shall be provided. The space between the accessible counter surface and any projecting objects above the accessible counter shall be 12 inches (305 mm) minimum.

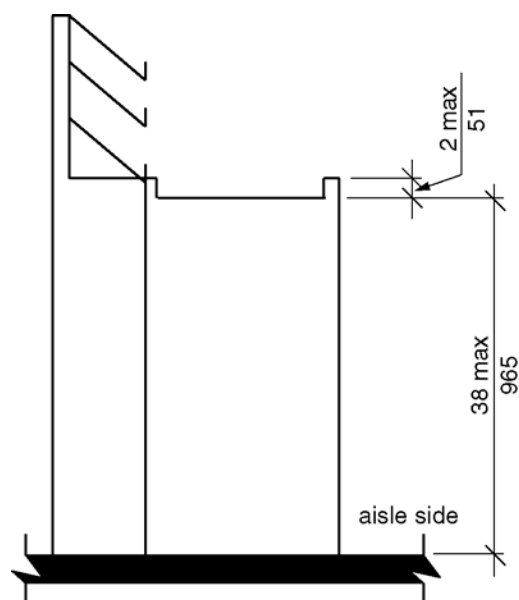
**Exception:** Where the counter surface is less than 36 inches (915 mm) in length, the entire counter surface shall be 26 inches (660 mm) minimum to 36 inches (915 mm) maximum in height above the floor. (9-10-12 PC2.3)

**904.3.3 Forward Approach.** A portion of the public use side of the counter surface 30 inches (760 mm) minimum in length and 36 inches (915 mm) maximum in height above the floor shall be provided. A clear floor space complying with Section 305, positioned for a forward approach to the accessible counter, shall be provided. Knee and toe clearance complying with Section 306 shall be provided under the accessible counter. The space between the accessible counter surface and any projecting objects above the accessible counter shall be 12 inches (305 mm) minimum. (9-10-12) (9-10-12 PC2)

**904.4 Checkout Aisles.** Checkout aisles shall comply with Section 904.4.

**904.4.1 Aisle.** Aisles shall comply with Section 403.

**904.4.2 Counters.** The checkout counter surface shall be 38 inches (965 mm) maximum in height above the floor. The top of the counter edge protection shall be 2 inches (51 mm) maximum above the top of the counter surface on the aisle side of the checkout counter.



*Figure 904.4.2 - Height of checkout counters*

**904.4.3 Check Writing Surfaces.** Where provided, check writing surfaces shall comply with Section

902.4.

**904.5 Food Service Lines.** Counters in food service lines shall comply with Section 904.5.

**904.5.1 Self-Service Shelves and Dispensing Devices.** Self-service shelves and dispensing devices for tableware, dishware, condiments, food and beverages shall comply with Section 308.

**904.5.2 Tray Slides.** The tops of tray slides shall be 28 inches (710 mm) minimum and 34 inches (865 mm) maximum above the floor.

**904.6 Security Glazing.** Where counters or teller windows have security glazing to separate personnel from the public, a method to facilitate voice communication shall be provided. Telephone handset devices, if provided, shall comply with Section 704.3.

## **905 Storage Facilities**

**905.1 General.** Accessible built-in storage facilities shall comply with Section 905. (9-1-12) (ed.)

**EXCEPTION:** Kitchen cabinets shall not be required to comply with this section (9-13-12) (ed.)

**905.2 Clear Floor Space.** A clear floor space complying with Section 305 shall be provided.

**905.3 Height.** Accessible storage elements shall comply with at least one of the reach ranges specified in Section 308. (ed.)

**905.4 Operable Parts.** Operable parts of storage facilities shall comply with Section 309.

## **906 Charging Stations. (8-5-12)**

**906.1 General.** A charging station shall consist of a grounded duplex outlet.

**906.2 Clear Floor Space.** A clear floor space complying with Section 305 shall be provided at the charging station.

**906.3 Height.** Accessible charging stations shall comply with at least one of the reach ranges specified in Section 308. (ed.)

## **907 Gaming Machines and Tables (9-12-12)**

**907.1 Clear Floor Space.** Accessible gaming machines and tables shall have a clear floor space complying with Section 305 positioned for transfer or for use by an individual seated in a wheelchair. Clear floor spaces required at gaming machines and tables shall be permitted to overlap. (9-12-12) (ed.)

## Chapter 10. Recreational Facilities

### 1001 General

**1001.1 Scope.** Recreational facilities required to be accessible by the scoping provisions adopted by the administrative authority shall comply with the applicable provisions of Chapter 10.

### 1001.2 Special Provisions

**1001.2.1 General Exceptions.** The following shall not be required to **comply with this standard** or to be on an accessible route: **(ed.)**

1. Raised structures used solely for refereeing, judging, or scoring a sport.
2. Water slides.
3. Animal containment areas that are not for public use.
4. Raised boxing or wrestling rings.
5. Raised diving boards and diving platforms.
6. Bowling lanes that are not required to provide wheelchair spaces.
7. Mobile or portable amusement rides.
8. Amusement rides that are controlled or operated by the rider.
9. Amusement rides designed primarily for children, where children are assisted on and off the ride by an adult.
10. Amusement rides that do not provide amusement ride seats.
11. Shooting facilities with firing positions on free-standing platforms that are elevated above grade 12 feet (3660 mm) minimum provided that the aggregate area of elevated firing positions is 500 square feet (46 m<sup>2</sup>) maximum.(11-1-12)

**1001.2.2 Area of Sport Activity.** Areas of sport activity shall be served by an accessible route and shall not be required to be accessible except as provided in **Chapter 10**. **Within areas of sports activity exempted in this chapter, the floor and ground surfaces shall not be required to comply with Section 302. (3-1-12)** **Within areas of sports activity exempted in this chapter, changes in level shall not be required to comply with Section 303. (3-1-12)(A117.1 7-5-16)**

**1001.3 Protruding Objects.** Protruding objects on circulation paths shall comply with Section 307.

#### EXCEPTIONS:

1. Within areas of sport activity, protruding objects on circulation paths shall not be required to comply with Section 307.
2. Within play areas, protruding objects on circulation paths shall not be required to comply with Section 307 provided that ground level accessible routes provide vertical clearance complying with Section 1008.2.

**1001.4 Animal Containment Areas.** **Within animal containment areas not exempted by Section 1001.2.1, floor and ground surfaces shall not be required to be stable, firm, and slip resistant.** **Animal containment areas not exempted by Section 1001.2.1 shall not be required to comply with Section 303. (3-1-12)**

### 1002 Amusement Rides.

**1002.1 General.** ~~Accessible~~ amusement rides shall comply with Section 1002. **(ed.)**

**1002.2 Accessible Routes.** Accessible routes serving amusement rides shall comply with Chapter 4.

**EXCEPTIONS:**

1. In load or unload areas and on amusement rides, where complying with Section 405.2 is not structurally or operationally feasible, ramp slope shall be permitted to be 1:8 maximum.
2. In load or unload areas and on amusement rides, handrails provided along walking surfaces complying with Section 403 and required on ramps complying with Section 405 shall not be required to comply with Section 505 where complying is not structurally or operationally feasible.

**1002.3 Load and Unload Areas.** A turning space complying with Sections 304.2 and 304.3 shall be provided in load and unload areas.

**1002.4 Wheelchair Spaces in Amusement Rides.** Wheelchair spaces in amusement rides shall comply with Section 1002.4.

**1002.4.1 Floor Surface.** The floor surface of wheelchair spaces shall be stable and firm.

**1002.4.2 Slope.** The floor surface of wheelchair spaces shall have a slope not steeper than 1:48 when in the load and unload position.

**1002.4.3 Gaps.** Floors of amusement rides with wheelchair spaces and floors of load and unload areas shall be coordinated so that, when amusement rides are at rest in the load and unload position, the vertical difference between the floors shall be within plus or minus  $\frac{5}{8}$  inch (16 mm) and the horizontal gap shall be 3 inches (75 mm) maximum under normal passenger load conditions.

**EXCEPTION:** Where complying is not operationally or structurally feasible, ramps, bridge plates, or similar devices complying with the applicable requirements of 36 CFR 1192.83(c), listed in Section 106.2.1, shall be provided. [Handrails on the ramps, bridge plates or similar devices are permitted to comply with either the requirements of Section 505 or the requirements of 36 CFR 1192.83\(c\). \(11-3-12\)](#)

**1002.4.4 Clearances.** Clearances for wheelchair spaces shall comply with Section 1002.4.4.

**EXCEPTIONS:**

1. Where provided, securement devices shall be permitted to overlap required clearances.
2. Wheelchair spaces shall be permitted to be mechanically or manually repositioned.
3. Wheelchair spaces shall not be required to comply with Section 307.4.

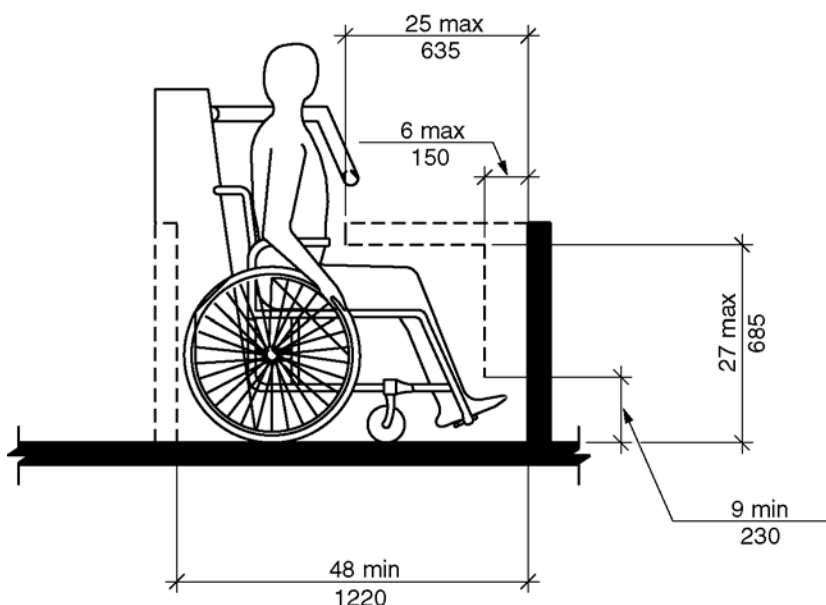
**1002.4.4.1 Width and Length.** Wheelchair spaces shall provide a clear width of 30 inches (760 mm) minimum and a clear length of 48 inches (1220 mm) minimum measured to 9 inches (230 mm) minimum above the floor.

**1002.4.4.2 Side Entry.** Where wheelchair spaces are entered only from the side, amusement rides shall be designed to permit sufficient maneuvering clearance for individuals using a wheelchair or mobility aid to enter and exit the ride.

**1002.4.4.3 Permitted Protrusions in Wheelchair Spaces.** Objects are permitted to protrude a distance of 6 inches (150 mm) maximum along the front of the wheelchair space, where located 9 inches (230 mm) minimum and 27 inches (685 mm) maximum above the floor of the wheelchair space. Objects are permitted to protrude a distance of 25 inches (635 mm) maximum along the front of the wheelchair space,



where located more than 27 inches (685 mm) above the floor of the wheelchair space.



*Figure 1002.4.4.3 - Protrusions in wheelchair spaces in amusement rides*

**1002.4.5 Ride Entry.** Openings providing entry to wheelchair spaces on amusement rides shall provide a clear width of 32 inches (815 mm) minimum.

**1002.4.6 Approach.** One side of the wheelchair space shall adjoin an accessible route when in the load and unload position.

**1002.4.7 Companion Seats.** Where the interior width of the amusement ride is greater than 53 inches (1345 mm), seating is provided for more than one rider, and the wheelchair is not required to be centered within the amusement ride, a companion seat shall be provided for each wheelchair space.

**1002.4.7.1 Shoulder-to-Shoulder Seating.** Where an amusement ride provides shoulder-to-shoulder seating, companion seats shall be shoulder-to-shoulder with the adjacent wheelchair space.

**EXCEPTION:** Where shoulder-to-shoulder companion seating is not operationally or structurally feasible, complying with this requirement shall be required to the maximum extent practicable.

**1002.5 Amusement Ride Transfer Devices and Seats Designed for Transfer.** Amusement ride transfer devices and seats designed for transfer shall comply with Section 1002.5 when positioned for loading and unloading. (11-4-12)

**1002.5.1 Clear Floor Space.** A clear floor space complying with Section 305 shall be provided in the load and unload area adjacent to the amusement ride transfer devices and seats designed for transfer. (11-4-12)

**1002.5.2 Transfer Height.** The height of amusement ride transfer devices and seats designed for transfer shall be 14 inches (355 mm) minimum and 24 inches (610 mm) maximum measured from the surface of the load and unload area. (11-4-12)

**1002.5.3 Transfer Entry.** Where openings are provided for transfer to amusement ride seats, the openings shall provide clearance for transfer from a wheelchair or mobility aid to the amusement ride seat.

**1002.5.4 Wheelchair Storage Space.** Wheelchair storage spaces complying with Section 305 shall be provided in or adjacent to unload areas for each required amusement ride transfer device and seat designed for transfer and shall not overlap any required means of egress or accessible route. (11-4-12)

### **1003 Recreational Boating Facilities**

**1003.1 General.** Accessible recreational boating facilities shall comply with Section 1003. (ed.)

**1003.2 Accessible Routes.** Accessible routes serving recreational boating facilities, including gangways and floating piers, shall comply with Chapter 4 except as modified by the exceptions in Section 1003.2.

**1003.2.1 Boat Slips.** An accessible route shall serve boat slips.

#### **EXCEPTIONS:**

1. Where an existing gangway or series of gangways is replaced or altered, an increase in the length of the gangway shall not be required to comply with Section 1103.2.
2. Gangways shall not be required to comply with the maximum rise specified in Section 405.6.
3. Where the total length of a gangway or series of gangways serving as part of a required accessible route is 80 feet (24 m) minimum, gangways shall not be required to comply with Section 405.2.
4. Where facilities contain fewer than 25 boat slips and the total length of the gangway or series of gangways serving as part of a required accessible route is 30 feet (9145 mm) minimum, gangways shall not be required to comply with Section 405.2.
5. Where gangways connect to transition plates, landings specified by Section 405.7 shall not be required.
6. Where gangways and transition plates connect and are required to have handrails, handrail extensions shall not be required. Where handrail extensions are provided on gangways or transition plates, the handrail extensions shall not be required to be parallel with the floor.
7. The cross slope specified in Sections 403.3 and 405.3 for gangways, transition plates, and floating piers that are part of accessible routes shall be measured in the static position.
8. Changes in level complying with Sections 303.3 and 303.4 shall be permitted on the surfaces of gangways and piers. (11-5-12)
9. Cleats and other boat securement devices shall not be required to comply with Section 308. (11-2-12)

**1003.2.2 Boarding Piers at Boat Launch Ramps.** An accessible route shall serve boarding piers.

#### **EXCEPTIONS:**

1. Accessible routes serving floating boarding piers shall be permitted to use Exceptions 1, 2, 5, 6, 7, 8 and 9 in Section 1003.2.1. (11-2-12)
2. Where the total length of the gangway or series of gangways serving as part of a required accessible route is 30 feet (9145 mm) minimum, gangways shall not be required to comply with Section 405.2.

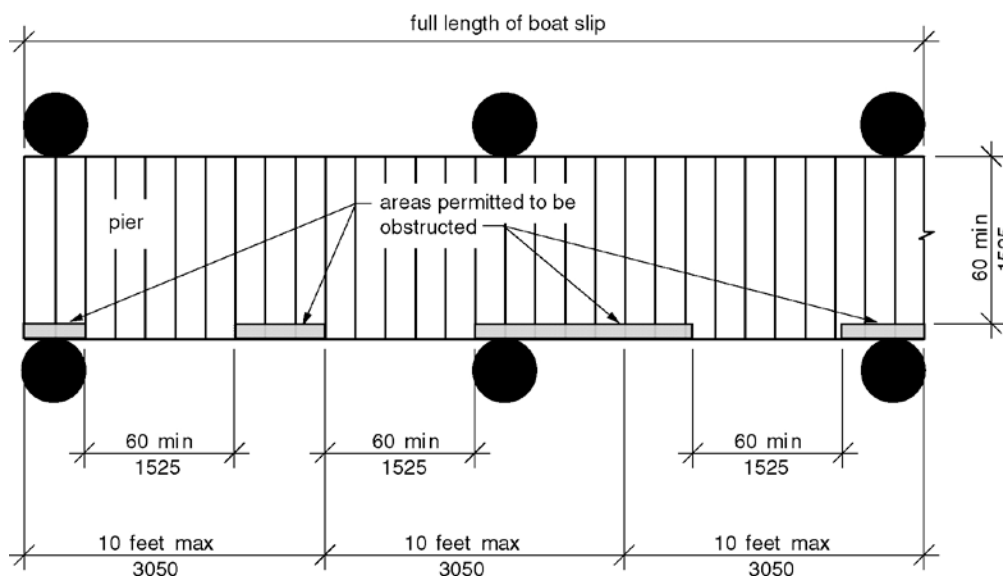
- Where the accessible route serving a floating boarding pier or skid pier is located within a boat launch ramp, the portion of the accessible route located within the boat launch ramp shall not be required to comply with Section 405.

**1003.3 Clearances.** Clearances at boat slips and on boarding piers at boat launch ramps shall comply with Section 1003.3.

**1003.3.1 Boat Slip Clearance.** At boat slips and on boarding piers at boat launch ramps shall provide clear pier space 60 inches (1525 mm) minimum in width that extend the full length of the boat slips or boarding pier. Each 10 feet (3050 mm) of linear pier edge serving boat slips or boarding pier shall contain at least one continuous clear opening 60 inches (1525 mm) minimum in width. (11-6-12)

**EXCEPTIONS:**

- Clear pier space shall be permitted to be 36 inches (915 mm) minimum in width and 24 inches (610 mm) maximum in length, provided that multiple 36-inch (915 mm) wide segments are separated by segments that are 60 inches (1525 mm) minimum in width and 60 inches (1525 mm) minimum in length.
- Edge protection shall be permitted at the continuous clear openings, provided the edge protection is 4 inches (100 mm) maximum in height and 2 inches (51 mm) maximum in width.
- In existing piers for boat slips, clear pier space shall be permitted to be located perpendicular to the boat slip and shall extend the width of the boat slip, where the facility has at least one boat slip complying with Section 1003.3, and further compliance with Section 4403.3 1003.3 would result in a reduction in the number of boat slips available or result in a reduction of the widths of existing slips. (11-6-12)



*Figure 1003.3.1(a) Boat slip and boarding pier clearance*

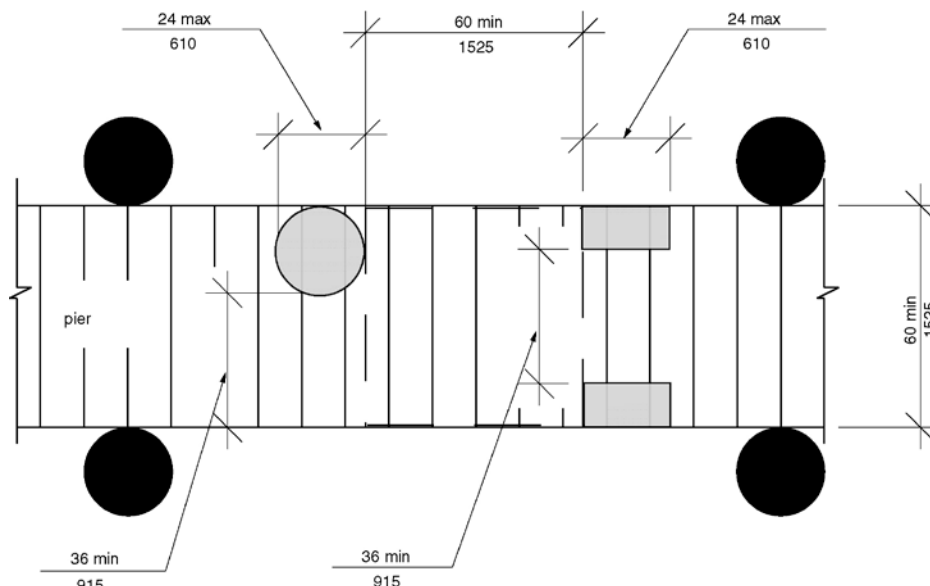


Figure 1003.3.1(b) (Exception 1) Clear pier space reduction at boat slips and boarding piers

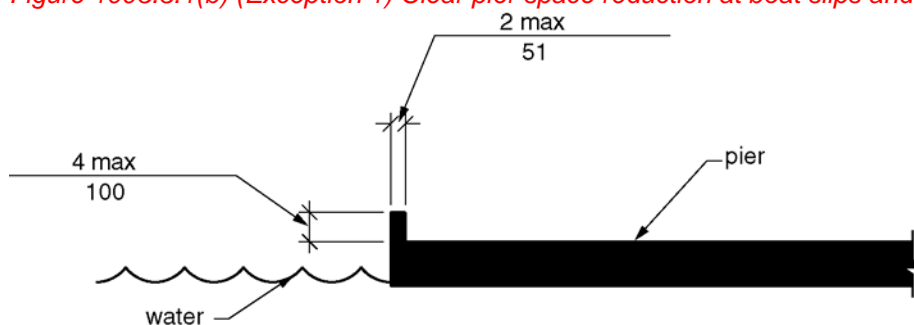


Figure 1003.3.1(c) (Exception 2) Edge protection at boat slips and boarding piers

## 1004 Exercise Machines and Equipment

**1004.1 Clear Floor Space.** Accessible exercise machines and equipment shall have a clear floor space complying with Section 305 positioned for transfer or for use by an individual seated in a wheelchair. Clear floor spaces required at exercise machines and equipment shall be permitted to overlap. **(ed.)**

**1004.2 Operable Parts.** The operable parts of exercise machines and exercise equipment shall not be required to comply with Section 309.

## 1005 Fishing Piers and Platforms

**1005.1 Accessible Routes.** Accessible routes serving fishing piers and platforms, including gangways and floating piers, shall comply with Chapter 4.

### EXCEPTIONS:

1. Accessible routes serving floating fishing piers and platforms shall be permitted to use Exceptions 1, 2, 5, 6, 7 and 8 in Section 1003.2.1.
2. Where the total length of the gangway or series of gangways serving as part of a required accessible route is 30 feet (9145 mm) minimum, gangways shall not be required to comply with Section 405.2.

**1005.2 Railings.** Where provided along the perimeter of fishing piers or platforms, railings, or guards, shall comply with Section 1005.2. (11-7-12)

**EXCEPTION:** Where a guard complying with the applicable building code is provided, the guard shall not be required to comply with Section 1005.2. (11-7-12)

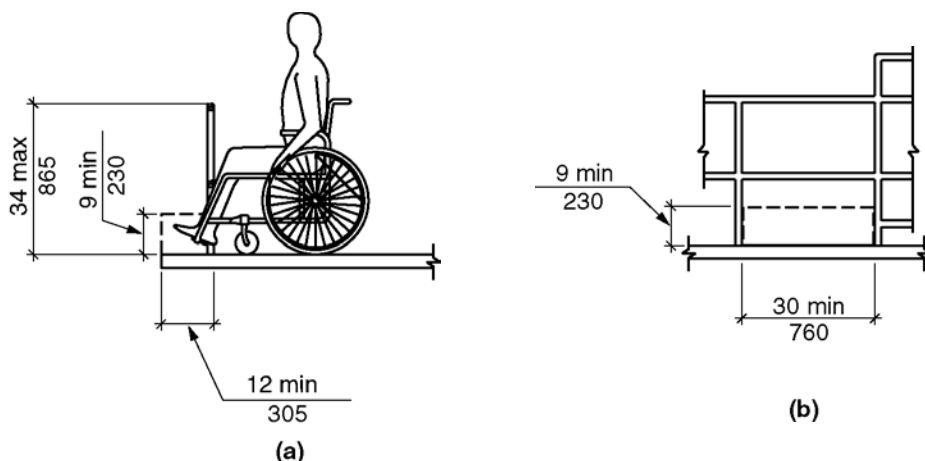
**1005.2.1 Height.** A minimum of 25 percent of the railings shall be 34 inches (865 mm) maximum above the ground or deck surface. (11-7-12)

**1005.2.1.1 Dispersion.** Railings required to comply with Section 1005.2.1 shall be dispersed throughout the fishing pier or platform. (11-7-12)

**1005.3 Edge Protection.** Where railings complying with Section 1005.2 are provided, edge protection complying with Section 1005.3.1 or 1005.3.2 shall be provided. (11-7-12)

**1005.3.1 Curb or Barrier.** Curbs or barriers shall be a minimum of 2 inches (51 mm) in height above the surface of the fishing pier or platform. (11-7-12)

**1005.3.2 Extended Ground or Deck Surface.** The ground or deck surface shall extend 12 inches (305 mm) minimum beyond the inside face of the railing. Toe clearance shall be provided and shall be 30 inches (760 mm) minimum in width and 9 inches (230 mm) minimum in height above the ground or deck surface beyond the railing.



*Figure 1005.3.2 - Extended ground or deck surface at fishing piers and platforms*

**1005.4 Clear Floor Space.** At each location where there are railings complying with Section 1005.2.1, a clear floor space complying with Section 305 shall be provided. Where there are no railings, guards, or handrails, at least one clear floor space complying with Section 305 shall be provided on the fishing pier or platform. (11-7-12)

**1005.5 Turning Space.** At least one turning space complying with Section 304.3 shall be provided on fishing piers and platforms.

## 1006 Golf Facilities

**1006.1 General.** Golf facilities shall comply with Section 1006.

**1006.2 Accessible Routes.** Accessible routes serving teeing grounds, practice teeing grounds, putting greens, practice putting greens, teeing stations at driving ranges, course weather shelters, golf car rental areas, bag drop areas, and course toilet rooms shall comply with Chapter 4. [Exterior routes shall be 48](#)

inches (1220 mm) minimum in width. Where guards, barriers or rails are provided, accessible routes shall be 60 inches (1525 mm) minimum in clear width. (11-9-12) (11-8-12)

**EXCEPTION:** Accessible golf car passages in accordance with Section 1006.3 shall be permitted to be used for all or part of accessible routes required by this section. (11-8-12)

**1006.2.1 Teeing Grounds.** Where one teeing ground is provided for a hole, the teeing ground shall be designed and constructed so that a golf car can enter and exit the teeing ground. Where two teeing grounds are provided for a hole, the teeing ground closest to the hole shall be designed and constructed so that a golf car can enter and exit the teeing ground. Where three or more teeing grounds are provided for a hole, at least two teeing grounds, including the teeing ground closest to the hole, shall be designed and constructed so that a golf car can enter and exit each teeing ground. (11-8-12)

**EXCEPTION:** Where existing golf courses are being altered, the forward teeing ground shall not be required to be one of the teeing grounds on a hole designed and constructed so that a golf car can enter and exit the teeing ground where compliance is not feasible due to terrain. (11-8-12)

**1006.2.2 Putting Greens.** Putting greens shall be designed and constructed so that a golf car can enter and exit the putting green. (11-8-12)

**1006.2.3 Practice Putting Greens, Practice Teeing Grounds, and Teeing Stations at Driving Ranges.** At least 5 percent, but no fewer than one, of practice putting greens, practice teeing grounds, and teeing stations at driving ranges shall be designed and constructed so that a golf car can enter and exit. (11-8-12)

**1006.2.4 Weather Shelters.** Where provided, weather shelters shall be designed and constructed so that a golf car can enter and exit the weather shelter. A clear floor space 60 inches (1525 mm) minimum by 96 inches (2440 mm) minimum shall be provided within weather shelters. (11-8-12)

**1006.3 Golf Car Passages.** Golf car passages shall comply with Section 1006.3.

**1006.3.1 Clear Width.** The clear width of golf car passages shall be 48 inches (1220 mm) minimum.

**1006.3.2 Barriers.** Where curbs or other constructed barriers prevent golf cars from entering a fairway, openings 60 inches (1525 mm) minimum in width shall be provided at intervals not to exceed 75 yards (69 m).

## 1007 Miniature Golf Facilities

**1007.1 General.** Miniature golf facilities shall comply with Section 1007.

**1007.2 Accessible Routes.** Accessible routes serving holes on miniature golf courses shall comply with Chapter 4.

**EXCEPTION:** Accessible routes located on playing surfaces of miniature golf holes shall be permitted to comply with the following: (11-10-12)

1. Playing surfaces shall not be required to comply with Section 302.2.
2. Where accessible routes intersect playing surfaces of holes, a curb that is 1 inch (25 mm) maximum in height and 32 inches (815 mm) minimum in width shall be permitted.
3. A slope of 1:4 maximum shall be permitted for a rise of 4 inches (100 mm) maximum.
4. Ramp landing slopes specified by Section 405.7.1 shall be permitted to be 1:20 maximum.

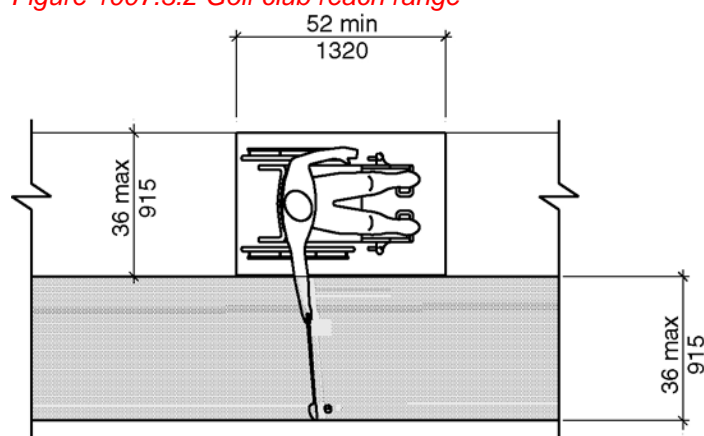
5. Ramp landing length specified by Section 405.7.3 shall be permitted to be 48 inches (1220 mm) minimum.
6. Ramp landing size at a change in direction specified by Section 405.7.4 shall be permitted to be 48 inches (1220 mm) minimum by 60 inches (1525 mm) minimum.
7. Handrails shall not be required along ramps located on the playing surface.(11-10-12)

**1007.3 Miniature Golf Holes.** Miniature golf holes shall comply with Section 1007.3.

**1007.3.1 Start of Play.** A clear floor space 48 inches (1220 mm) minimum by 60 inches (1525 mm) minimum with slopes not steeper than 1:48 shall be provided at the start of play.

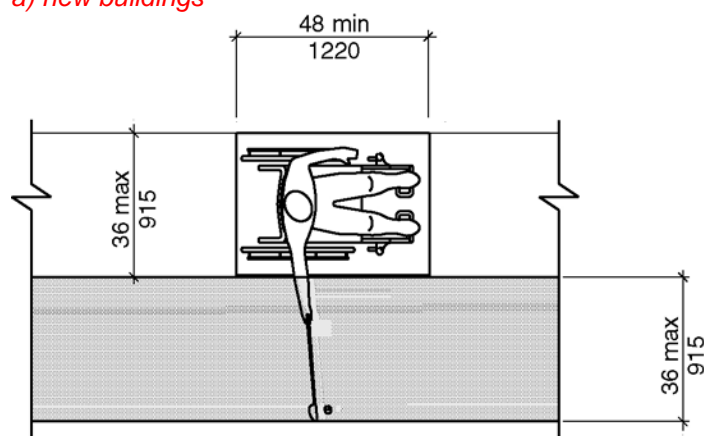
**1007.3.2 Golf Club Reach Range Area.**

*Figure 1007.3.2 Golf club reach range*



Note: Running Slope of Clear Floor or Ground Space Not Steeper Than 1:20

*a) new buildings*



Note: Running Slope of Clear Floor or Ground Space Not Steeper Than 1:20

*b) existing building*

**1007.3.2.1 New building.** In new buildings, all areas within holes where golf balls rest shall be within 36 inches (915 mm) maximum of a clear floor space 36 inches (915 mm) minimum in width and 52 inches (1320 mm) minimum in length complying with Section 305 having a running slope not steeper than 1:20. The clear floor space shall be served by an accessible route. (3-13H-12) (3-6-12 PC2)



**1007.3.2.2 Existing buildings.** In existing buildings, all areas within holes where golf balls rest shall be within 36 inches (915 mm) maximum of a clear floor space 36 inches (915 mm) minimum in width and 48 inches (1220 mm) minimum in length complying with Section 305 having a running slope not steeper than 1:20. The clear floor space shall be served by an accessible route. (3-6-12 PC2)

## **1008 Play Areas**

**1008.1 Scope.** Play areas shall comply with 1008.

**1008.2 Accessible Routes for Play Areas.** Play areas shall provide accessible routes in accordance with Section 1008.2. Accessible routes serving play areas shall comply with Chapter 4 except as modified by Section 1008.4.

**1008.2.1 Ground Level and Elevated Play Components.** At least one accessible route shall be provided within the play area. The accessible route shall connect ground level play components required to comply with Section 1008.3.2.1 and elevated play components required to comply with Section 1008.3.2.2, including entry and exit points of the play components.

**1008.2.2 Soft Contained Play Structures.** Where three or fewer entry points are provided for soft contained play structures, at least one entry point shall be on an accessible route. Where four or more entry points are provided for soft contained play structures, at least two entry points shall be on an accessible route.

**1008.3 Age Groups.** Play areas for children ages 2 and over shall comply with Section 1008.3. Where separate play areas are provided within a site for specific age groups, each play area shall comply with Section 1008.3.

### **EXCEPTIONS:**

1. Play areas located in family child care facilities where the proprietor actually resides shall not be required to comply with Section 1008.3.
2. In existing play areas, where play components are relocated for the purposes of creating safe use zones and the ground surface is not altered or extended for more than one use zone, the play area shall not be required to comply with Section 1008.3.
3. Amusement attractions shall not be required to comply with Section 1008.3.
4. Where play components are altered and the ground surface is not altered, the ground surface shall not be required to comply with Section 1008.4.1.6 unless required by the authority having jurisdiction.

**1008.3.1 Additions.** Where play areas are designed and constructed in phases, the requirements of Section 1008.3 shall apply to each successive addition so that when the addition is completed, the entire play area complies with all the applicable requirements of Section 1008.3.

**1008.3.2 Play Components.** Where provided, play components shall comply with Section 1008.3.2.

**1008.3.2.1 Ground Level Play Components.** Ground level play components shall be provided in the number and types required by Section 1008.3.2.1. Ground level play components that are provided to comply with Section 1008.3.2.1.1 shall be permitted to satisfy the additional number required by Section 1008.3.2.1.2 if the minimum required types of play components are satisfied. Where two or more required ground level play components are provided, they shall be dispersed throughout the play area and integrated with other play components.

**1008.3.2.1.1 Minimum Number and Types.** Where ground level play components are provided, at least



one of each type shall be on an accessible route and shall comply with Section 1008.4.3.

**1008.3.2.1.2 Additional Number and Types.** Where elevated play components are provided, ground level play components shall be provided in accordance with Table 1008.3.2.1.2 and shall comply with Section 1008.4.3.

**EXCEPTION:** If at least 50 percent of the elevated play components are connected by a ramp and at least 3 of the elevated play components connected by the ramp are different types of play components, the play area shall not be required to comply with Section 1008.3.2.1.2.

<b>Number of Elevated Play Components Provided</b>	<b>Minimum Number of Ground Level Play Components Required to be on an Accessible Route</b>	<b>Minimum Number of Different Types of Ground Level Play Components Required to be on an Accessible Route</b>
1	Not applicable	Not applicable
2 to 4	1	1
5 to 7	2	2
8 to 10	3	3
11 to 13	4	3
14 to 16	5	3
17 to 19	6	3
22 to 22	7	4
23 to 25	8	4
26 and over	8, plus 1 for each additional 3, or fraction thereof, over 25	5

**1008.3.2.2 Elevated Play Components.** Where elevated play components are provided, at least 50 percent shall be on an accessible route and shall comply with Section 1008.4.3.

**1008.4 Accessible Routes Within Play Areas.** Accessible routes within play areas shall comply with Section 1108.4. (11-12-12)

**1008.4.1 Accessible Routes.** Accessible routes serving play areas shall comply with Chapter 4 and Section 1008.4.1 Where accessible routes serve ground level play components, the vertical clearance shall be 80 inches (2030 mm) minimum in height. (11-12-12)

**EXCEPTIONS:**

1. Where 20 or more elevated play components are provided, transfer systems complying with Section 1008.4.2. shall be permitted to be used as part of an accessible route for a maximum of 25 percent of the play components.
2. Where fewer than 20 elevated play components are provided, transfer systems complying with Section 1008.4.2 shall be permitted to be used as part of an accessible route.
3. Where transfer systems are provided, an elevated play component shall be permitted to connect to another elevated play component as part of an accessible route.
4. Accessible routes serving soft contained play structures shall be permitted to use transfer systems complying with Section 1008.4.2 as part of an accessible route.

5. Where the surface of the accessible route, clear floor spaces, or turning spaces serving water play components is submerged, complying with Sections 302, 403.3, 405.2, 405.3, and 1008.4.1.6 shall not be required.
6. Accessible routes serving water play components shall be permitted to use transfer systems complying with Section 1008.4.2 to connect elevated play components in water. **(11-12-12)**

**1008.4.1.1 Clear Width.** Accessible routes connecting play components shall provide a clear width complying with Section **1008.4.1.1**

**1008.4.1.1.1 Ground Level.** At ground level, the clear width of accessible routes shall be 60 inches (1525 mm) minimum.

**EXCEPTIONS:**

1. In play areas less than 1000 square feet (93 m<sup>2</sup>), the clear width of accessible routes shall be permitted to be 44 inches (1120 mm) minimum, if at least one turning space complying with Section 304.3 is provided where the restricted accessible route exceeds 30 feet (9145 mm) in length.
2. The clear width of accessible routes shall be permitted to be 36 inches (915 mm) minimum for a distance of 60 inches (1525 mm) maximum provided that multiple reduced width segments are separated by segments that are 60 inches (1525 mm) minimum in width and 60 inches (1525 mm) minimum in length.

**1008.4.1.1.2 Elevated.** The clear width of accessible routes connecting elevated play components shall be 36 inches (915 mm) minimum.

**EXCEPTIONS:**

1. The clear width of accessible routes connecting elevated play components shall be permitted to be reduced to 32 inches (815 mm) minimum for a distance of 24 inches (610 mm) maximum provided that reduced width segments are separated by segments that are 48 inches (1220 mm) minimum in length and 36 inches (915 mm) minimum in width.
2. The clear width of transfer systems connecting elevated play components shall be permitted to be 24 inches (610 mm) minimum.

**1008.4.1.2 Ramps.** Within play areas, ramps connecting ground level play components and ramps connecting elevated play components shall comply with Section 405 except as modified by Section **1008.4.1.2**. **(11-14-12)**

**1008.4.1.2.1 Ground Level.** Ramp runs connecting ground level play components shall have a running slope not steeper than 1:16.

**1008.4.1.2.2 Elevated.** The rise for any ramp run connecting elevated play components shall be 12 inches (305 mm) maximum.

**1008.4.1.2.3 Handrails.** Where required on ramps serving play components, the handrails shall comply with Section 505 except as modified by Section **1008.4.1.2.3**

**EXCEPTIONS:**

1. Handrails shall not be required on ramps located within ground level use zones.

2. Handrail extensions shall not be required.

**1008.4.1.2.3.1 Handrail Gripping Surfaces.** Handrail gripping surfaces with a circular cross section shall have an outside diameter of 0.95 inch (24 mm) minimum and 1.55 inches (39 mm) maximum. Where the shape of the gripping surface handrail is non-circular, the handrail shall provide an equivalent gripping surface.

**1008.4.1.2.3.2 Handrail Height.** The top of handrail gripping surfaces shall be 20 inches (510 mm) minimum and 28 inches (710 mm) maximum above the ramp surface.

**1008.4.1.3 Ground Surfaces.** Ground surfaces on accessible routes, clear floor spaces, and turning spaces shall comply with Section 1008.4.1.3.

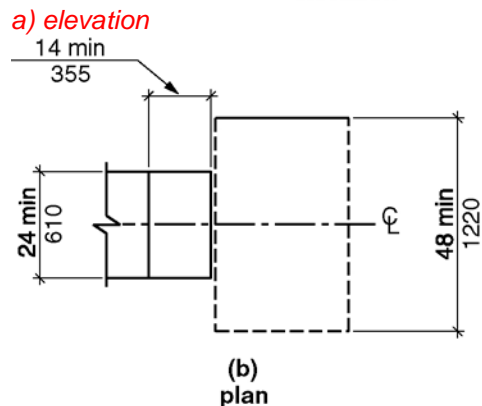
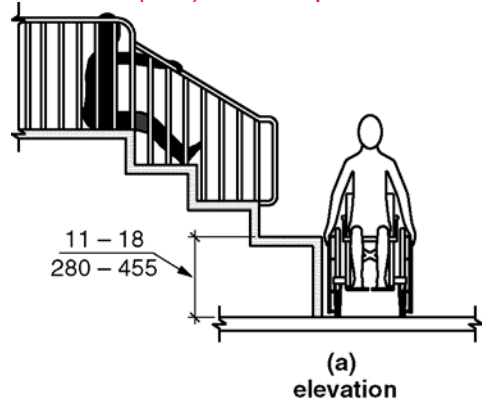
**1008.4.1.3.1 Surface Condition.** Ground surfaces shall be stable, firm and slip resistant. Ground surfaces shall be inspected and maintained regularly and frequently to ensure continued compliance with this requirement.

**1008.4.1.3.2 Use Zones.** Ground surfaces located within use zones shall comply with ASTM F 1292 listed in Section 106.2.11.

**1008.4.2 Transfer Systems.** Where transfer systems are provided to connect to elevated play components, the transfer systems shall comply with Section 1008.4.2.

**1008.4.2.1 Transfer Platforms.** Transfer platforms shall be provided where transfer is intended from wheelchairs or other mobility aids. Transfer platforms shall comply with Section 1008.4.2.1.

*1008.4.2.1(a&b) Transfer platforms*



*b) plan*

**1008.4.2.1.1 Size.** Transfer platforms shall have level surfaces 14 inches (355 mm) minimum in depth

and 24 inches (610 mm) minimum in width.

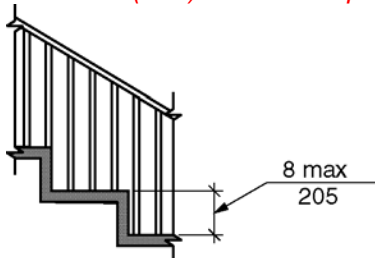
**1008.4.2.1.2 Height.** The top of the transfer platforms shall be 11 inches (280 mm) minimum and 18 inches (455 mm) maximum in height above the floor.

**1008.4.2.1.3 Transfer Space.** A transfer space complying with Sections 305.2 and 305.3 shall be provided adjacent to the transfer platform. The 48-inch (1220 mm) minimum length dimension of the transfer space shall be centered on and parallel to the 24-inch (610 mm) minimum length side of the transfer platform. The side of the transfer platform serving the transfer space shall be unobstructed.

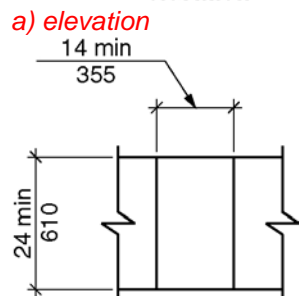
**1008.4.2.1.4 Transfer Supports.** At least one means of support for transferring shall be provided.

**1008.4.2.2 Transfer Steps.** Transfer steps shall be provided where movement is intended from transfer platforms to levels with elevated play components required to be on accessible routes. Transfer steps shall comply with Section 1008.4.2.2.

*1008.4.2.2(a&b) Transfer steps*



(a)  
elevation



(b)  
plan

*b) plan*

**1008.4.2.2.1 Size.** Transfer steps shall have level surfaces 14 inches (355 mm) minimum in depth and 24 inches (610 mm) minimum in width.

**1008.4.2.2.2 Height.** Each transfer step shall be 8 inches (205 mm) maximum in height.

**1008.4.2.2.3 Transfer Supports.** At least one means of support for transferring shall be provided.

**1008.4.3 Play Components.** Ground level play components on accessible routes and elevated play components connected by ramps shall comply with Section 1008.4.3.

**1008.4.3.1 Turning Space.** At least one turning space complying with Section 304 shall be provided on the same level as play components. Where swings are provided, the turning space shall be located immediately adjacent to the swing.

**1008.4.3.2 Clear Floor Space.** Clear floor space complying with Sections 305.2 and 305.3 shall be provided at play components.

**1008.4.3.3 Play Tables.** Where play tables are provided, knee clearance 24 inches (610 mm) minimum in height, 17 inches (430 mm) minimum in depth, and 30 inches (760 mm) minimum in width shall be provided. The tops of rims, curbs, or other obstructions shall be 31 inches (785 mm) maximum in height.

**EXCEPTION:** Play tables designed and constructed primarily for children 5 years and younger shall not be required to provide knee clearance where the clear floor space required by Section 1008.4.3.2 is arranged for a parallel approach.

**1008.4.3.4 Entry Points and Seats.** Where play components require transfer to entry points or seats, the entry points or seats shall be 11 inches (280 mm) minimum and 24 inches (610 mm) maximum from the clear floor space.

**EXCEPTION:** Entry points of slides shall not be required to comply with Section 1008.4.3.4.

**1008.4.3.5 Transfer Supports.** Where play components require transfer to entry points or seats, at least one means of support for transferring shall be provided.

## **1009 Swimming Pools, Wading Pools, Hot tubs and Spas**

**1009.1 General.** Swimming pools, wading pools, hot tubs and spas shall comply with Section 1009.

**1009.1.1 Swimming pools.** At least two accessible means of entry shall be provided for swimming pools. Accessible means of entry shall be swimming pool lifts complying with Section 1009.2; sloped entries complying with Section 1009.3; transfer walls complying with Section 1009.4, transfer systems complying with Section 1009.5; and pool stairs complying with Section 1009.6. At least one accessible means of entry provided shall comply with Section 1009.2 or 1009.3(A117.1 7-5-16)

### **EXCEPTIONS:**

1. Where a swimming pool has less than 300 linear feet (91 m) of swimming pool wall, no more than one accessible means of entry shall be required.
2. Wave action pools, leisure rivers, sand bottom pools, and other pools where user access is limited to one area shall not be required to provide more than one accessible means of entry provided that the accessible means of entry is a swimming pool lift complying with Section 1009.2, a sloped entry complying with Section 1009.3, or a transfer system complying with Section 1009.5.
3. Catch pools shall not be required to provide an accessible means of entry provided that the catch pool edge is on an accessible route.

**1009.1.2 Wading pools.** At least one sloped entry complying with Section 1009.3 shall be provided in wading pools.

**1009.1.3 Hot tubs and Spas.** At least one accessible means of entry shall be provided for hot tubs and spas. Accessible means of entry shall comply with swimming pool lifts complying with Section 1009.2; transfer walls complying with Section 1009.4; or transfer systems complying with Section 1009.5.

**EXCEPTION:** Where hot tubs or spas are provided in a cluster, no more than 5 percent, but not less than one hot tub or spa in each cluster shall be required to comply with Section 1009.1.3.

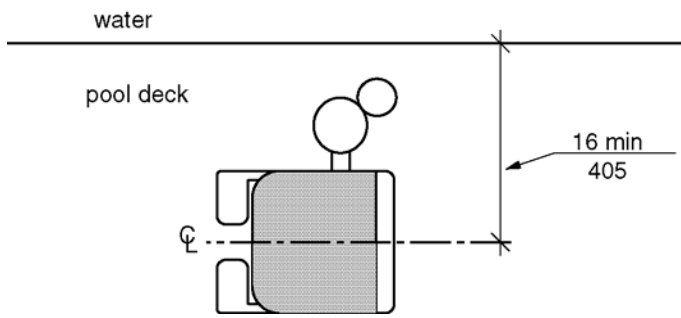
**1009.2 Pool Lifts.** Pool lifts shall comply with Section 1009.2.

**1009.2.1 Pool Lift Location.** Pool lifts shall be located where the water level does not exceed 48 inches (1220 mm).

**EXCEPTIONS:**

1. Where the entire pool depth is greater than 48 inches (1220 mm), compliance with Section 1009.2.1 shall not be required.
2. Where multiple pool lift locations are provided, no more than one pool lift shall be required to be located in an area where the water level is 48 inches (1220 mm) maximum.

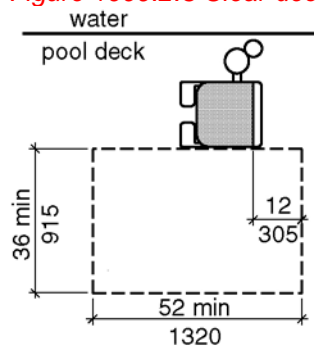
**1009.2.2 Seat Location.** In the raised position, the centerline of the seat shall be located over the deck and 16 inches (405 mm) minimum from the edge of the pool. The deck surface between the centerline of the seat and the pool edge shall have a slope not steeper than 1:48.



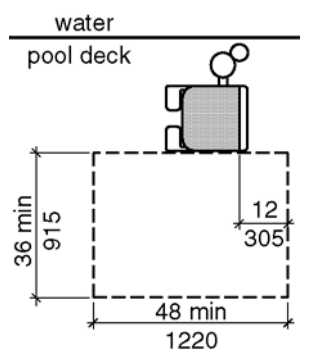
*Figure 1009.2.2 - Pool lift seat location*

**1009.2.3 Clear Deck Space**

*Figure 1009.2.3 Clear deck space at pool lifts*



*a) New buildings*

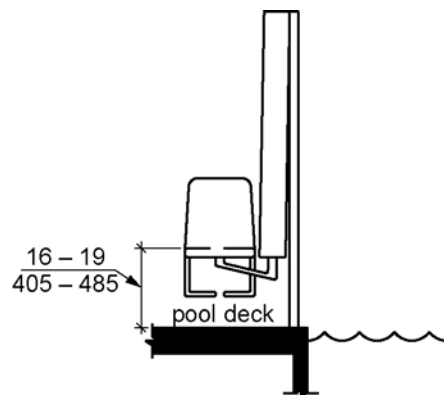


*b) Existing buildings*

**1009.2.3.1 New buildings.** In new buildings, on the side of the seat opposite the water, a clear deck space shall be provided parallel with the seat. The space shall be 36 inches (915 mm) minimum in width and shall extend forward 52 inches (1320 mm) minimum from a line located 12 inches (305 mm) behind the rear edge of the seat. The clear deck space shall have a slope not steeper than 1:48. (3-13K-12) (3-6-12 PC2)

**1009.2.3.2 Existing buildings.** In existing buildings, on the side of the seat opposite the water, a clear deck space shall be provided parallel with the seat. The space shall be 36 inches (915 mm) minimum in width and shall extend forward 48 inches (1220 mm) minimum from a line located 12 inches (305 mm) behind the rear edge of the seat. The clear deck space shall have a slope not steeper than 1:48. (3-6-12 PC2)

**1009.2.4 Seat Height.** The height of the lift seat shall be designed to allow a stop at 16 inches (405 mm) minimum and 19 inches (485 mm) maximum measured from the deck to the top of the seat surface when in the raised (load) position.



*Figure 1009.2.4 - Pool lift seat height*

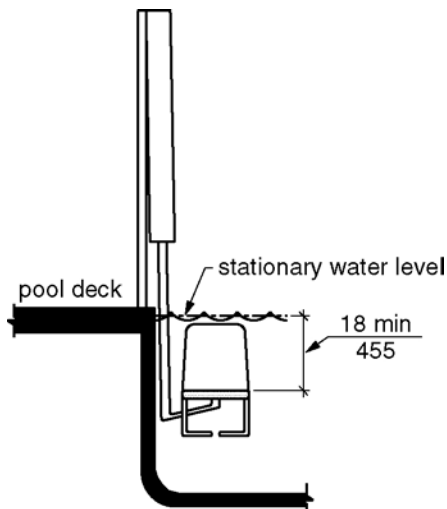
**1009.2.5 Seat.** The seat shall be 16 inches (405 mm) minimum in width, provide a back rest, and be of a firm and stable design.

**1009.2.6 Footrests and Armrests.** Footrests shall be provided and shall move with the seat. If provided, the armrest positioned opposite the water shall be removable or shall fold clear of the seat when the seat is in the raised (load) position.

**EXCEPTION:** Footrests shall not be required on pool lifts provided in spas.

**1009.2.7 Operation.** The lift shall be capable of unassisted operation from both the deck and water levels. Controls and operating mechanisms shall be unobstructed when the lift is in use and shall comply with Section 309.4.

**1009.2.8 Submerged Depth.** The lift shall be designed so that the seat will submerge to a water depth of 18 inches (455 mm) minimum below the stationary water level.



*Figure 1009.2.8 - Pool lift submerged depth*

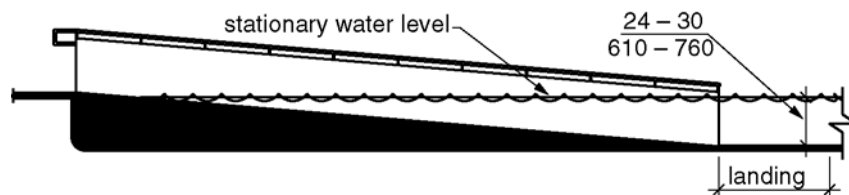
**1009.2.9 Lifting Capacity.** Single person pool lifts shall have a weight capacity of 300 pounds. (136 kg) minimum and be capable of sustaining a static load of at least one and a half times the rated load.

**1009.3 Sloped Entries.** Sloped entries shall comply with Section 1009.3.

**1009.3.1 Sloped Entry Route.** Sloped entries shall comply with Sections 402, 403 and 405 except as modified by Sections 1009.3.1 through 1009.3.3. (11-16-12)

**EXCEPTION:** Where sloped entries are provided, the surfaces shall not be required to be slip resistant.

**1009.3.2 Submerged Depth.** Sloped entries for swimming pools shall comply with Section 1009.3.2.1. Sloped entries for wading pools shall comply with Section 1009.3.2.2.



*Figure 1009.3.2 - Sloped entry submerged depth*

**1009.3.2.1 Swimming Pools.** Sloped entries for swimming pools shall extend to a depth of 24 inches (610 mm) minimum and 30 inches (760 mm) maximum below the stationary water level. Where landings are required by Section 405.7, at least one landing shall be located 24 inches (610 mm) minimum and 30 inches (760 mm) maximum below the stationary water level.

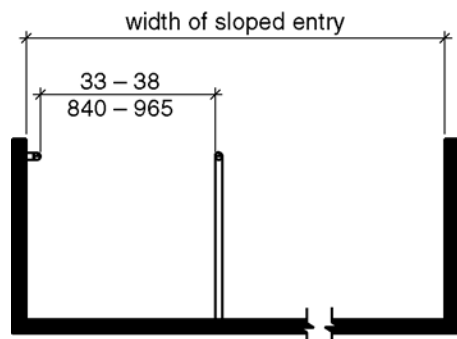
**Section 1009.3.2.2 Wading Pools.** In wading pools, the sloped entry shall extend to the deepest part of the wading pool.

**1009.3.3 Handrails.** At least two handrails complying with Section 505 shall be provided on the sloped entry. The clear width between required handrails shall be 33 inches (840 mm) minimum and 38 inches (965 mm) maximum.

**EXCEPTIONS:**



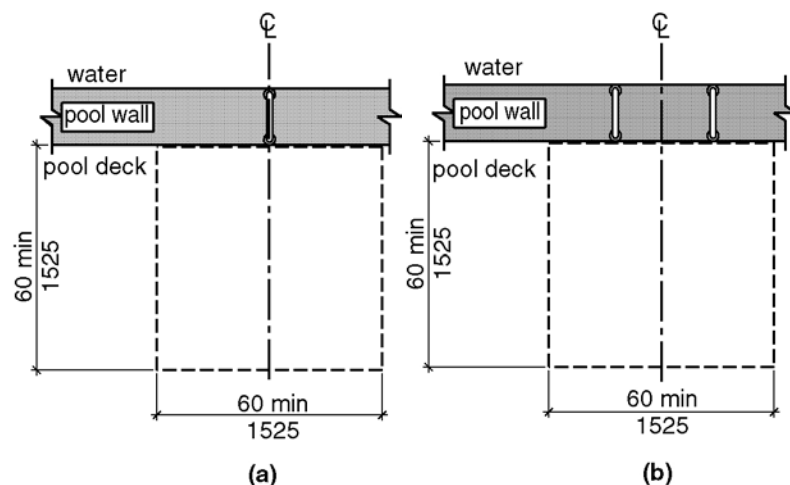
1. Handrail extensions specified by Section 505.10.1 shall not be required at the bottom landing serving a sloped entry.
2. Where a sloped entry is provided for wave action pools, leisure rivers, sand bottom pools, and other pools where user access is limited to one area, the handrails shall not be required to comply with the clear width requirements of Section 1009.3.3.
3. Sloped entries in wading pools shall not be required to provide handrails complying with Section 1009.3.3. If provided, handrails on sloped entries in wading pools shall not be required to comply with Section 505.



*Figure 1009.3.3 - Handrails for sloped entry*

**1009.4 Transfer Walls.** Transfer walls shall comply with Section 1009.4.

**1009.4.1 Clear Deck Space.** A clear deck space of 60 inches (1525 mm) minimum by 60 inches (1525 mm) minimum with a slope not steeper than 1:48 shall be provided at the base of the transfer wall. Where one grab bar is provided, the clear deck space shall be centered on the grab bar. Where two grab bars are provided, the clear deck space shall be centered on the clearance between the grab bars.



*Figure 1009.4.1(a&b) - Clear deck space at transfer walls*

**1009.4.2 Height.** The height of the transfer wall shall be 16 inches (405 mm) minimum and 19 inches (485 mm) maximum measured from the deck.

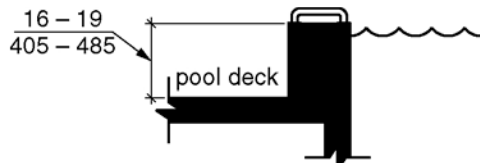


Figure 1009.4.2 - Transfer wall height

**1009.4.3 Wall Depth and Length.** The transfer wall shall be 12 inches (305 mm) minimum and 16 inches (405 mm) maximum in depth. The transfer wall shall be 60 inches (1525 mm) minimum in length and shall be centered on the clear deck space.

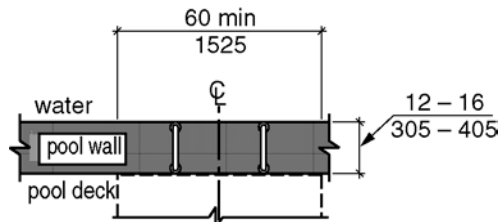


Figure 1009.4.3 - Depth and length of transfer walls

**1009.4.4 Surface.** Surfaces of transfer walls shall not be sharp and shall have rounded edges.

**1009.4.5 Grab Bars.** At least one grab bar complying with Sections 609.1 through 609.3 and 609.5 through 609.8 shall be provided on the transfer wall. Grab bars shall be perpendicular to the pool wall and shall extend the full depth of the transfer wall. The top of the gripping surface shall be 4 inches (100 mm) minimum and 6 inches (150 mm) maximum above the transfer wall. Where one grab bar is provided, clearance shall be 24 inches (610 mm) minimum on both sides of the grab bar. Where two grab bars are provided, clearance between grab bars shall be 24 inches (610 mm) minimum.

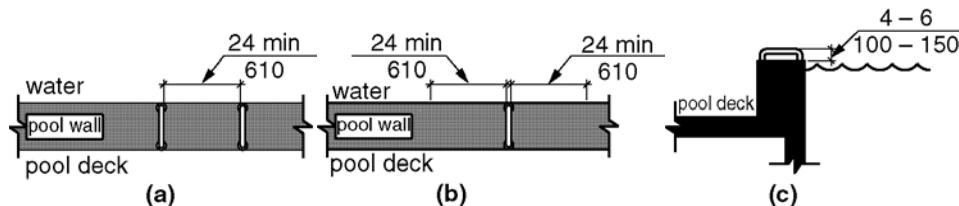
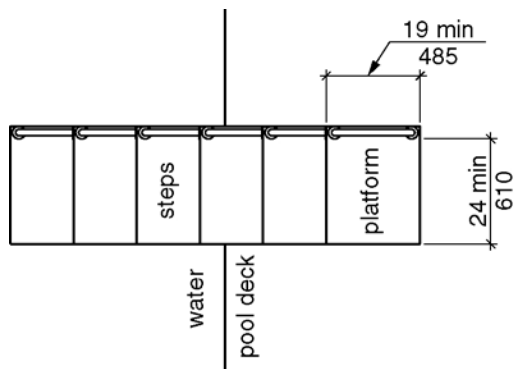


Figure 1009.4.5 (a, b & c) - Grab bars for transfer walls

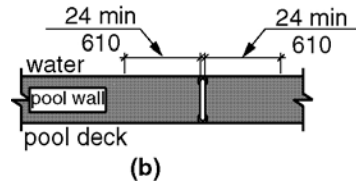
**1009.5 Transfer Systems.** Transfer systems shall comply with Section 1009.5.

**1009.5.1 Transfer Platform.** A transfer platform shall be provided at the head of each transfer system. Transfer platforms shall provide a clear depth of 19 inches (485 mm) minimum and a clear width of 24 inches (610 mm) minimum.



*Figure 1009.5.1 - Size of transfer platforms*

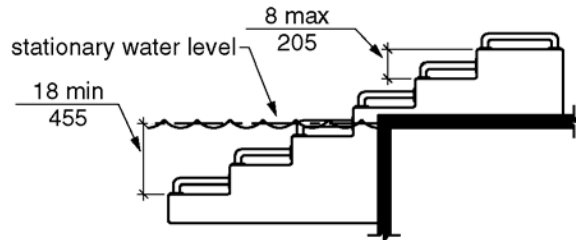
**1009.5.2 Transfer Space.** A transfer space of 60 inches (1525 mm) minimum by 60 inches (1525 mm) minimum with a slope not steeper than 1:48 shall be provided at the base of the transfer platform surface. The transfer space shall be centered along a 24-inch (610 mm) minimum side of the transfer platform. The side of the transfer platform serving the transfer space shall be unobstructed.



*Figure 1009.5.2 - Clear deck space at transfer platforms*

**1009.5.3 Height.** The height of the transfer platform shall comply with Section 1009.4.2.

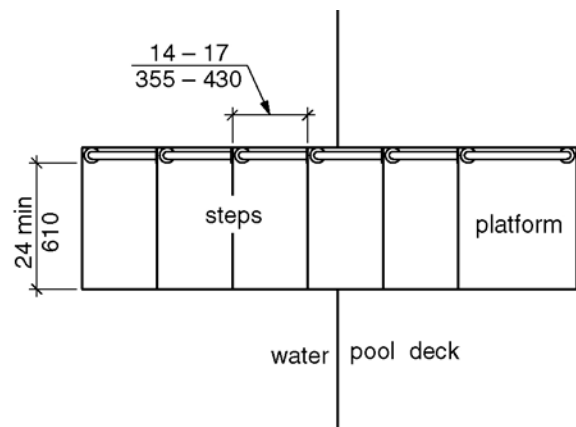
**1009.5.4 Transfer Steps.** Transfer steps shall be 8 inches (205 mm) maximum in height. The surface of the bottom tread shall extend to a water depth of 18 inches (455 mm) minimum below the stationary water level.



*Figure 1009.5.4 - Transfer steps*

**1009.5.5 Surface.** The surface of the transfer system shall not be sharp and shall have rounded edges.

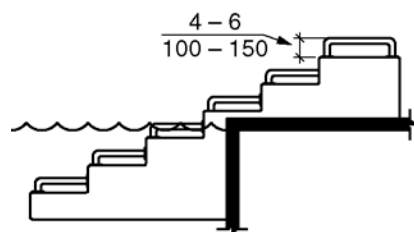
**1009.5.6 Size.** Each transfer step shall have a tread clear depth of 14 inches (355 mm) minimum and 17 inches (430 mm) maximum and shall have a tread clear width of 24 inches (610 mm) minimum.



*Figure 1009.5.6 - Size of transfer steps*

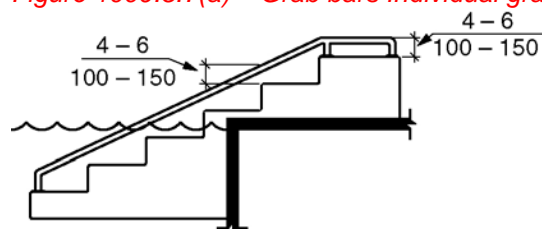
**1009.5.7 Grab Bars.** At least one grab bar on each transfer step and the transfer platform or a continuous grab bar serving each transfer step and the transfer platform shall be provided. Where a grab bar is provided on each step, the tops of gripping surfaces shall be 4 inches (100 mm) minimum and 6 inches (150 mm) maximum above each step and transfer platform. Where a continuous grab bar is provided, the top of the gripping surface shall be 4 inches (100 mm) minimum and 6 inches (150 mm)

maximum above the step nosing and transfer platform. Grab bars shall comply with Sections 609.1 through 609.3 and 609.5 through 609.8 and be located on at least one side of the transfer system. The grab bar located at the transfer platform shall not obstruct transfer.



(a)  
individual grab bars

*Figure 1009.5.7(a) – Grab bars Individual grab bars*



(b)  
continuous grab bars

*Figure 1009.5.7(b) - Grab bars Continuous grab bars*

**1009.6 Pool Stairs.** Pool stairs shall comply with Section 1009.6.

**1009.6.1 Pool Stairs.** Pool stairs shall comply with Sections 504.2 through 504.5. (11-17-12)

**EXCEPTION:** Pool step risers shall not be required to be 4 inches (100 mm) minimum and 7 inches (180 mm) maximum in height provided that riser heights are uniform.

**1009.6.2 Handrails.** At least two handrails complying with Section 505 shall be provided on the pool stairs. The width between handrails shall be 20 inches (510 mm) minimum and 24 inches (610 mm) maximum. (11-17-12)

**EXCEPTION:** Handrail extensions required by Section 505.10.3 shall not be required at the bottom on pool stairs. (11-17-12)

## 1010 Shooting Facilities with Firing Positions

**1010.1 Turning Space.** A circular turning space complying with Section 304.3.1 with slopes not steeper than 1:48 shall be provided at shooting facility firing positions.

**1010.2 Firing position counters.** Where a firing position requires shooting over a counter or wall, the top of the counter or wall shall be 34 inches maximum in height above the floor surface. If counter surfaces are provided at other firing positions of the same type, equivalent counter surfaces shall be provided at the accessible firing position required to comply with Section 1010.1.(11-18-12) (ed.)

# Chapter 11. Dwelling Units and Sleeping Units

## 1101 General

**1101.1 Scoping.** Dwelling units and sleeping units required by the scoping provisions adopted by the administrative authority to be Accessible units, Type A units, Type B units, Type C (Visitable) units or units with communication features shall comply with the applicable provisions of Chapter 11. (ed.)

## 1102 Accessible Units

**1102.1 General.** Accessible units shall comply with Section 1102.

**1102.2 Primary Entrance.** The accessible primary entrance shall be on an accessible route from public and common areas. The primary entrance shall not be to a bedroom unless it is the only entrance. (ed.)

**1102.3 Accessible Route.** Accessible routes within Accessible units shall comply with Section 1102.3.

**1102.3.1 Location.** At least one accessible route shall connect all spaces and elements that are a part of the unit. Accessible routes shall coincide with or be located in the same area as a general circulation path.

**EXCEPTION:** An accessible route is not required to unfinished attics and unfinished basements that are part of the unit.

**1102.3.2 Turning Space.** All rooms served by an accessible route shall provide a turning space complying with Section 304.

### EXCEPTIONS:

1. A turning space shall not be required in toilet rooms and bathrooms that are not required to comply with Section 1102.11.2.
2. A turning space is not required within closets or pantries that are 48 inches (1220 mm) maximum in depth.

**1102.3.3 Components.** Accessible routes shall consist of one or more of the following elements: walking surfaces with a slope not steeper than 1:20, doors and doorways, ramps, elevators, and platform lifts.

**1102.4 Walking Surfaces.** Walking surfaces that are part of an accessible route shall comply with Section 403.

**1102.5 Doors and Doorways.** The primary entrance door to the unit, and all other doorways intended for user passage, shall comply with Section 404.

### EXCEPTIONS:

1. Existing doors to hospital patient sleeping rooms shall be exempt from the requirement for space at the latch side provided the door is 44 inches (1120 mm) minimum in width.
2. In toilet rooms and bathrooms not required to comply with Section 1102.11.2, maneuvering clearances required by Section 404.2.3 shall not be required on the toilet room or bathroom side of the door. (ed.)
3. A turning space between doors in a series as required by Section 404.2.5 is not required.
4. Storm and screen doors shall not be required to comply with Section 404.2.5. (ed.)

5. Communicating doors between individual sleeping units shall not be required to comply with Section 404.2.5. (ed.)
6. At other than the primary entrance door, where exterior space dimensions of balconies are less than the required maneuvering clearance, door maneuvering clearance is not required on the exterior side of the door.
7. The maneuvering clearances required by Section 404 shall not be required within a closet or pantry complying with Exception 2 of Section 1102.3.2. (10-4-12) (ed.)

**1102.6 Ramps.** Ramps shall comply with Section 405.

**1102.7 Elevators.** Elevators within the unit shall comply with Section 407, 408, or 409.

**1102.8 Platform Lifts.** Platform lifts within the unit shall comply with Section 410.

**\*\*1102.9 Operable Parts.** Lighting controls, electrical panelboards, electrical switches and receptacle outlets, environmental controls, appliance controls, plumbing fixture controls, and user controls for security or intercom systems shall comply with Section 309. (5-22-12) (10-6-12) (10-10-12) (ed.)

**1102.10 Laundry Equipment.** Washing machines and clothes dryers shall comply with Section 611.

**1102.11 Toilet and Bathing Facilities.** At least one toilet and bathing facility shall comply with Section 1102.11.2. All other toilet and bathing facilities shall comply with Section 1102.11.1

**1102.11.1 Grab Bars and Shower Seat Reinforcement.** At fixtures in toilet and bathing facilities not required to comply with Section 1102.11.2, reinforcement in accordance with Section 1104.11.1 shall be provided.

**EXCEPTION:** Reinforcement is not required where Type B units are not provided in the structure.

**1102.11.2 Accessible Toilet and Bathing Facility.** At least one toilet and bathing facility shall comply with Section 603. At least one lavatory, one water closet and either a bathtub or shower within the unit shall comply with Sections 604 through 610. Such toilet and bathing fixtures shall be in a single toilet/bathing area, such that travel between fixtures does not require travel through other parts of the unit. (A117.1 8-4-16) (ed.)

**1102.11.2.1 Vanity Counter Top Space.** If vanity counter top space is provided in dwelling or sleeping units not required to be Accessible units within the same facility, equivalent vanity counter top space, in terms of size and proximity to the lavatory, shall also be provided in Accessible units.

**1102.11.2.2 Mirrors.** Mirrors above lavatories required to comply with Section 606 shall have the bottom edge of the reflecting surface 40 inches (1015 mm) maximum above the floor. (ed.)

**1102.12 Kitchens.** Kitchens shall comply with Section 804.

**1102.13 Windows.** Operable windows shall comply with Section 506.1.

**EXCEPTIONS:**

1. Windows in kitchens shall not be required to comply with Section 1102.13.
2. Windows in bathrooms shall not be required to comply with Section 1102.13. (5-22-12) (ed.)

**1102.14 Storage Facilities.** Where storage facilities are provided, at least one of each type shall comply with Section 905.

**EXCEPTION:** Kitchen cabinets shall not be required to comply with Section 1102.14.

**1102.15 Beds.** In at least one sleeping area, a minimum of five percent, but not less than one bed shall comply with Section 1102.15.

**1102.15.1 Clear Floor Space.** A clear floor space complying with Section 305 shall be provided on both sides of the bed. The clear floor space shall be positioned for parallel approach to the side of the bed.

**EXCEPTION:** Where a single clear floor space complying with Section 305 positioned for parallel approach is provided between two beds, a clear floor space shall not be required on both sides of the bed.

**1102.15.2 Bed Frames.** At least one bed shall be provided with an open bed frame.

**1102.15.3 Bed Height.** . At least one bed shall measure 17 to 23 inches (430 to 585 mm) high from the floor to the top of the uncompressed mattress. (10-13-12 PC1)

**1102.15.4 Wheelchair Charging Area.** The clear floor space complying with Section 1102.15.1 shall also serve as a wheelchair charging area complying with Section 906. (10-10-12 PC1, PC1.1)

### 1103 Type A Units

**1103.1 General.** Type A units shall comply with Section 1103.

**1103.2 Primary Entrance.** The **accessible** primary entrance shall be on an accessible route from public and common areas. The primary entrance shall not be to a bedroom unless it is the only entrance. (ed.)

**1103.3 Accessible Route.** Accessible routes within Type A units shall comply with Section 1103.3.

**1103.3.1 Location.** At least one accessible route shall connect all spaces and elements that are a part of the unit. Accessible routes shall coincide with or be located in the same area as a general circulation path.

**EXCEPTION:** An accessible route is not required to unfinished attics and unfinished basements that are part of the unit.

**1103.3.2 Turning Space.** All rooms served by an accessible route shall provide a turning space complying with Section 304.

#### EXCEPTIONS:

1. A turning space is not required in toilet rooms and bathrooms that are not required to comply with Section 1103.11.2.
2. A turning space is not required within closets or pantries that are 48 inches (1220 mm) maximum in depth.

**1103.3.3 Components.** Accessible routes shall consist of one or more of the following elements: walking surfaces with a slope not steeper than 1:20, doors and doorways, ramps, elevators, and platform lifts.

**1103.4 Walking Surfaces.** Walking surfaces that are part of an accessible route shall comply with Section 403.

**1103.5 Doors and Doorways.** The primary entrance door to the unit, and all other doorways intended for user passage, shall comply with Section 404.

#### EXCEPTIONS:



1. Thresholds at exterior sliding doors shall be permitted to be 3/4 inch (19 mm) maximum in height, provided they are beveled with a slope not greater than 1:2.- (10-16-12 PC1)
2. In toilet rooms and bathrooms not required to comply with Section 1103.11.2, maneuvering clearances required by Section 404.2.3 shall not be required on the toilet room or bathroom side of the door. (ed.)
3. A turning space between doors in a series as required by Section 404.2.5 is not required.
4. Storm and screen doors shall not be required to comply with Section 404.2.5. (ed.)
5. Communicating doors between individual sleeping units shall not be required to comply with Section 404.2.5. (ed.)
6. At other than the primary entrance door, where exterior space dimensions of balconies are less than the required maneuvering clearance, door maneuvering clearance is not required on the exterior side of the door.
7. The maneuvering clearances required by Section 404 shall not be required within a closet or pantry complying with Exception 2 of Section 1103.3.2. (10-4-12) (ed.)

**1103.6 Ramps.** Ramps shall comply with Section 405.

**1103.7 Elevators.** Elevators within the unit shall comply with Section 407, 408, or 409.

**1103.8 Platform Lifts.** Platform lifts within the unit shall comply with Section 410.

**1103.9 Operable Parts.** Lighting controls, electrical panelboards, electrical switches and receptacle outlets, environmental controls, appliance controls, plumbing fixture controls, and user controls for security or intercom systems shall comply with Section 309. (5-22-12) (10-6-12) (ed.)

**1103.10 Laundry Equipment.** Washing machines and clothes dryers shall comply with Section 611.

**1103.11 Toilet and Bathing Facilities.** At least one toilet and bathing facility shall comply with Section 1103.11.2. All toilet and bathing facilities shall comply with Section 1103.11.1.

**1103.11.1 Grab Bar and Shower Seat Reinforcement.** Reinforcement shall be provided for the future installation of grab bars complying with Section 604.5 at water closets; grab bars complying with Section 607.4 at bathtubs; and for grab bars and shower seats complying with Sections 608.3, 608.2.1.3, 608.2.2.3 and 608.2.3.2 at shower compartments.

**EXCEPTIONS:**

1. At fixtures not required to comply with Section 1103.11.2, reinforcement in accordance with Section 1104.11.1 shall be permitted.
2. Reinforcement is not required in a room containing only a lavatory and a water closet, provided the room does not contain the only lavatory or water closet on the accessible level of the dwelling unit.
3. Reinforcement for the water closet side wall vertical grab bar component required by Section 604.5 is not required.
4. Where the lavatory overlaps the water closet clearance in accordance with the exception to Section 1103.11.2.4.4 reinforcement at the water closet rear wall for a 24-inch (610 mm) minimum length grab bar, centered on the water closet, shall be provided.



**1103.11.2 General.** At least one toilet and bathing facility shall comply with Section 1103.11.2. At least one lavatory, one water closet and either a bathtub or shower within the unit shall comply with Section 1103.11.2. Such toilet and bathing fixtures shall be in a single toilet/bathing area, such that travel between fixtures does not require travel through other parts of the unit. (A117.1 8-4-16) (ed.)

**1103.11.2.1 Doors.** Doors shall not swing into the clear floor space or clearance for any fixture.

**EXCEPTION:** Where a clear floor space complying with Section 305.3 is provided within the room beyond the arc of the door swing.

**1103.11.2.2 Lavatory.** Lavatories shall comply with Section 606.

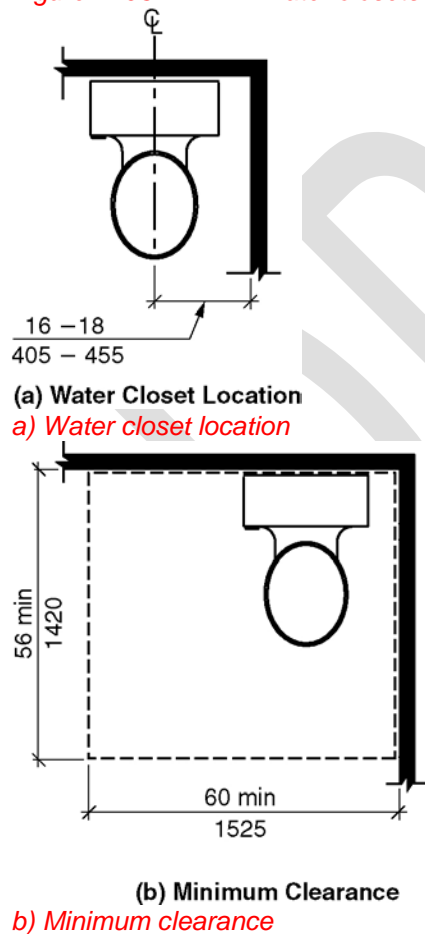
**EXCEPTION:** Cabinetry shall be permitted under the lavatory, provided the following criteria are met:

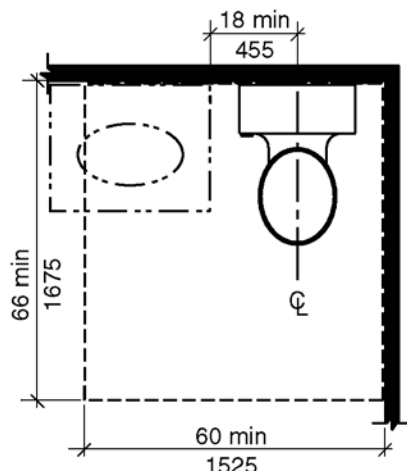
1. The cabinetry can be removed without removal or replacement of the lavatory;
2. The floor finish extends under the cabinetry; and
3. The walls behind and surrounding the cabinetry are finished.

**1103.11.2.3 Mirrors.** Mirrors above lavatories required to comply with Section 1103.11.2.2 shall have the bottom edge of the reflecting surface 40 inches (1015 mm) maximum above the floor. (ed.)

**1103.11.2.4 Water Closet.** Water closets shall comply with Section 1103.11.2.4.

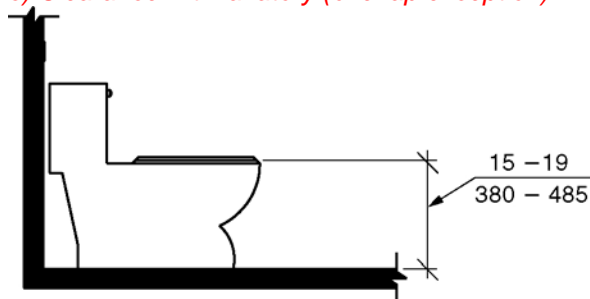
*Figure 1103.11.2.4 - Water closets in Type A units –*





(c) Clearance with Lavatory  
(Overlap Exception)

*c) Clearance with lavatory (overlap exception)*



(d) Water Closet Seat Height

*d) Water closet seat height*

**1103.11.2.4.1 Location.** The water closet shall be positioned with a wall to the rear and to one side. The centerline of the water closet shall be 16 inches (405 mm) minimum and 18 inches (455 mm) maximum from the sidewall.

**1103.11.2.4.2 Clearance Width.** A clearance around the water closet shall be 60 inches (1525 mm) minimum in width, measured perpendicular from the side wall.

**1103.11.2.4.3 Clearance Depth.** Clearance around the water closet shall be 56 inches (1420 mm) minimum in depth, measured perpendicular from the rear wall.

**1103.11.2.4.4 Clearance Overlap.** The required clearance around the water closet shall be permitted to overlap the water closet, associated grab bars, paper dispensers, coat hooks, shelves, accessible routes, clear floor space required at other fixtures, and the wheelchair turning space. No other fixtures or obstructions shall be located within the required water closet clearance.

**EXCEPTION:** A lavatory measuring 24 inches (610 mm) maximum in depth and complying with Section 1103.11.2.2 shall be permitted on the rear wall 18 inches (455 mm) minimum from the centerline of the water closet to the side edge of the lavatory where the clearance at the water closet is 66 inches (1675 mm) minimum measured perpendicular from the rear wall.

**1103.11.2.4.5 Height.** The top of the water closet seat shall be 15 inches (380 mm) minimum and 19 inches (485 mm) maximum above the floor, measured to the top of the seat.

**1103.11.2.4.6 Flush Controls.** Flush controls shall be hand-operated or automatic. Hand operated flush controls shall comply with Section 309. Hand-operated flush controls shall be located on the open side of the water closet.

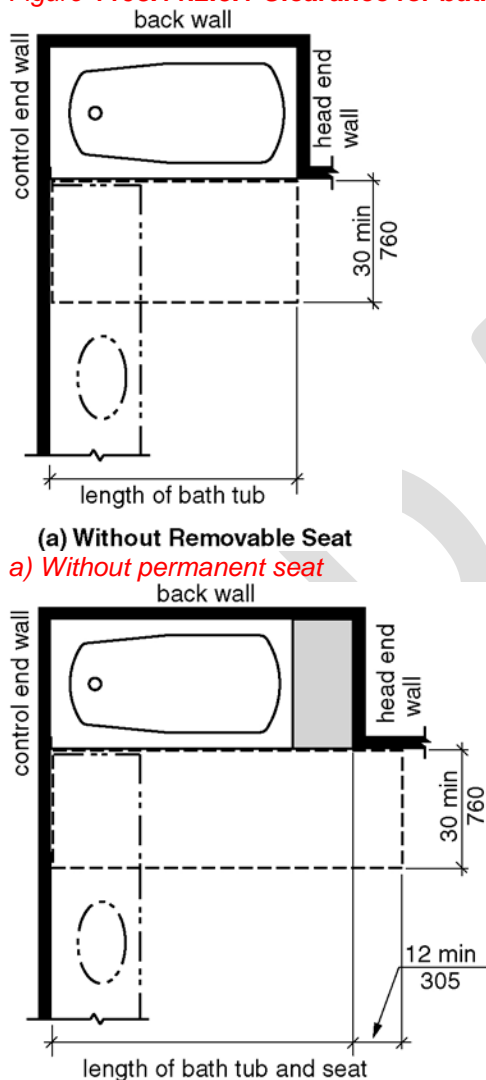
**1103.11.2.5 Bathing Fixtures.** The **accessible** bathing fixture shall be a bathtub complying with Section 1103.11.2.5.1 or a shower compartment complying with Section 1103.11.2.5.2. (ed.)

**1103.11.2.5.1 Bathtub.** Bathtubs shall comply with Section 607.

**EXCEPTION:** Counter tops and cabinetry shall be permitted at one end of the clearance, provided the following criteria are met:

1. The countertop and cabinetry can be removed;
2. The floor finish extends under the countertop and cabinetry; and
3. The walls behind and surrounding the countertop and cabinetry are finished.

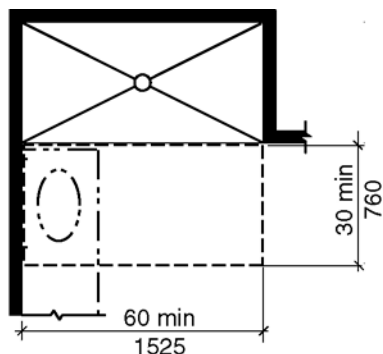
**Figure 1103.11.2.5.1 Clearance for bathtubs in Type A units**



**1103.11.2.5.2 Shower.** Showers shall comply with Section 608.

**EXCEPTION:** At standard roll-in shower compartments complying with Section 608.2.2, lavatories, counter tops and cabinetry shall be permitted at one end of the clearance, provided the following criteria are met:

1. The countertop and cabinetry can be removed;
2. The floor finish extends under the countertop and cabinetry; and
3. The walls behind and surrounding the countertop and cabinetry are finished.



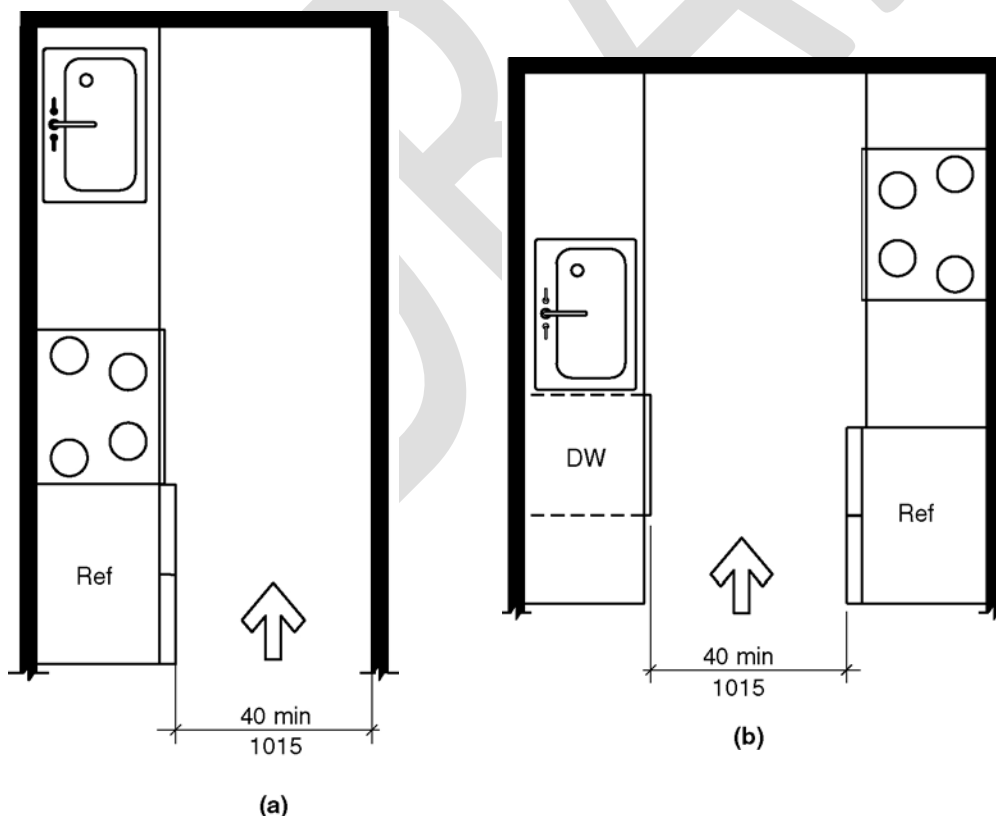
Note: Lavatory permitted per Section 608.2.2

*Figure 1103.11.2.5.2 Standard roll-in-type shower compartment in Type A units*

**1103.12 Kitchens.** Kitchens and kitchenettes shall comply with Section 1103.12.

**1103.12.1 Clearance.** Clearance complying with Section 1103.12.1 shall be provided.

**1103.12.1.1 Minimum Clearance.** Clearance between all opposing base cabinets, counter tops, appliances, or walls within kitchen work areas shall be 40 inches (1015mm) minimum.

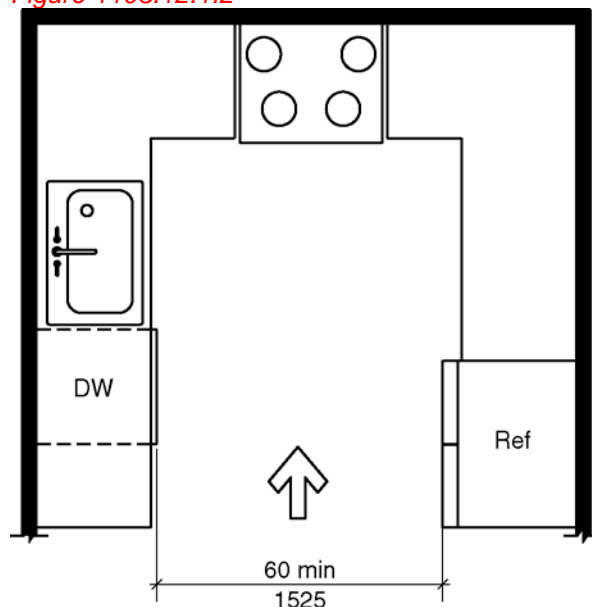


*Figure 1103.12.1.1 (a&b) Minimum kitchen clearance in Type A units*

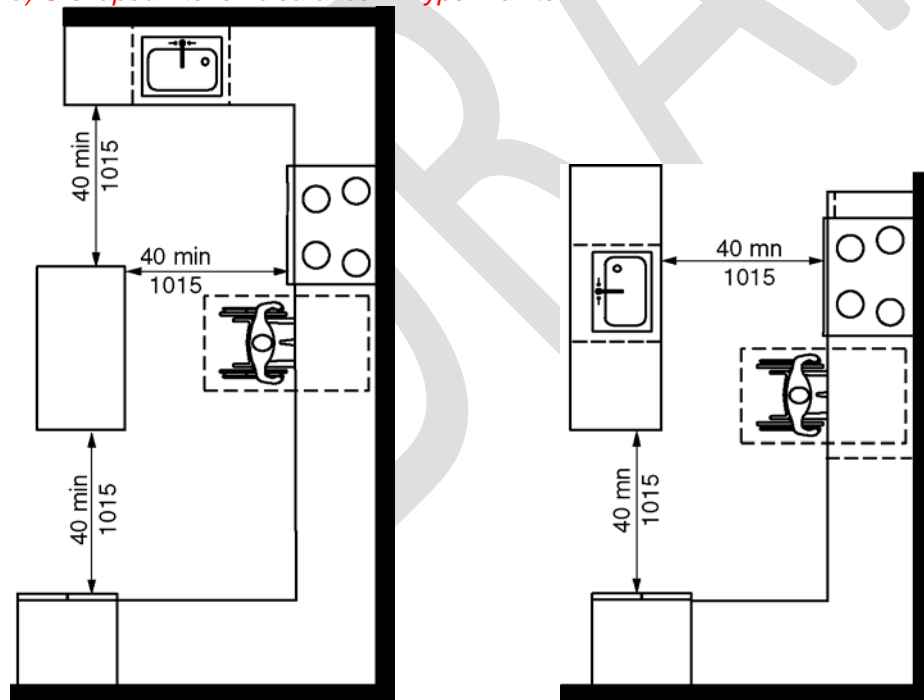
**1103.12.1.2 U-Shaped Kitchens.** In kitchens with counters, appliances, or cabinets on three contiguous sides, clearance between all opposing base cabinets, countertops, appliances, or walls within kitchen work areas shall be 60 inches (1525 mm) minimum.

**EXCEPTION:** U-shaped kitchens with an island shall be permitted to comply with Section 1103.12.1.1. (8-9-12)

Figure 1103.12.1.2



a) U-shaped kitchen clearance in Type A units



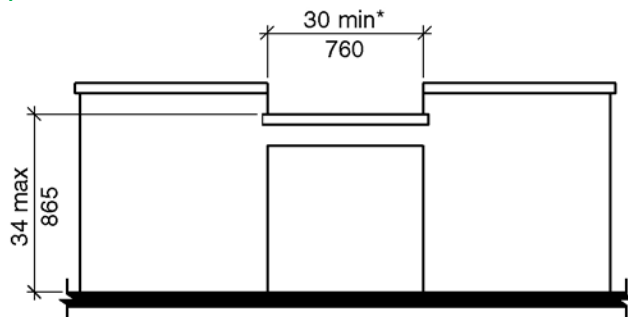
b) Exception

**1103.12.2 Clear Floor Space.** Clear floor spaces required by Sections 1103.12.3 through 1103.12.5 shall comply with Section 305.

**1103.12.3 Work Surface.** At least one section of counter shall provide an accessible work surface 30

inches (760 mm) minimum in length complying with Section 1103.12.3. (ed.)  
(8-10-12) (A117.1 8-4-16)

**EXCEPTION:** Spaces that do not provide a cooktop or conventional range shall not be required to provide an accessible work surface. (8-13-12)(8-10-12) (A117.1 8-4-16) (ed.)



\* 36 min. (915) if part of T-shaped turning space per Sections 304.3.2 and 1003.3.2

*Figure 1103.12.3 – Accessible Work surface in kitchen for Type A units(A117.1 8-4-16)*

**1103.12.3.1 Clear Floor Space.** A clear floor space, positioned for a forward approach to the work surface, shall be provided. Knee and toe clearance complying with Section 306 shall be provided. (9-2-12)

**EXCEPTION:** Cabinetry shall be permitted under the work surface, provided the following criteria are met:

1. The cabinetry can be removed without removal or replacement of the work surface,
2. The floor finish extends under the cabinetry, and
3. The walls behind and surrounding the cabinetry are finished.

**1103.12.3.2 Height.** The work surface shall be 34 inches (865 mm) maximum above the floor.

**EXCEPTION:** A counter that is adjustable to provide a work surface at variable heights 29 inches (735 mm) minimum and 36 inches (915 mm) maximum above the floor, or that can be relocated within that range without cutting the counter or damaging adjacent cabinets, walls, doors, and structural elements, shall be permitted.

**1103.12.3.3 Exposed Surfaces.** There shall be no sharp or abrasive surfaces under the exposed portions of work surface counters.

**1103.12.4 Sink.** Sinks shall comply with Section 1103.12.4.

**Exception:** A parallel approach complying with Section 305 and centered on the sink, shall be permitted to a kitchen sink in a space where a cook top or conventional range is not provided. (8-13-12)

*Figure 1103.12.4 - Kitchen sink for Type A units*

**1103.12.4.1 Clear Floor Space.** A clear floor space, positioned for a forward approach to the sink, shall be provided. Knee and toe clearance complying with Section 306 shall be provided.

**EXCEPTIONS:**

1. The requirement for knee and toe clearance shall not apply to more than one bowl of a multi-bowl sink.
2. Cabinetry shall be permitted to be added under the sink, provided the following criteria are met:

- 2.1. The cabinetry can be removed without removal or replacement of the sink,
  - 2.2. The floor finish extends under the cabinetry, and
  - 2.3. The walls behind and surrounding the cabinetry are finished.
3. A parallel approach complying with Section 305 and centered on the sink, shall be permitted at a kitchen sink in a space where a cook top or conventional range is not provided. (10-21-12)
  4. A parallel approach complying with Section 305 and centered on the sink, shall be permitted at wet bars. (10-21-12)

**1103.12.4.2 Height.** The front of the sink shall be 34 inches (865 mm) maximum above the floor, measured to the higher of the rim or counter surface.

**EXCEPTION:** A sink and counter that is adjustable to variable heights 29 inches (735 mm) minimum and 36 inches (915 mm) maximum above the floor, or that can be relocated within that range without cutting the counter or damaging adjacent cabinets, walls, doors and structural elements, provided rough-in plumbing permits connections of supply and drain pipes for sinks mounted at the height of 29 inches (735 mm), shall be permitted.

**1103.12.4.3 Faucets.** Faucets shall comply with Section 309.

**1103.12.4.4 Exposed Pipes and Surfaces.** Water supply and drain pipes under sinks shall be insulated or otherwise configured to protect against contact. There shall be no sharp or abrasive surfaces under sinks.

**1103.12.5 Appliances.** Where provided, kitchen appliances shall comply with Section 1103.12.5.

**1103.12.5.1 Operable Parts.** All appliance controls shall comply with Section 1103.9.

**EXCEPTIONS:**

1. Appliance doors and door latching devices shall not be required to comply with Section 309.4.
2. Bottom-hinged appliance doors, when in the open position, shall not be required to comply with Section 309.3.

**1103.12.5.2 Clear Floor Space.** A clear floor space, positioned for a parallel or forward approach, shall be provided at each kitchen appliance.

**1103.12.5.3 Dishwasher.** A clear floor space, positioned adjacent to the dishwasher door, shall be provided. The dishwasher door in the open position shall not obstruct the clear floor space for the dishwasher or an adjacent sink.

**1103.12.5.4 Cooktop.** Cooktops shall comply with Section 1103.12.5.4.

**1103.12.5.4.1 Approach.** A clear floor space, positioned for a parallel or forward approach to the cooktop, shall be provided.

**1103.12.5.4.2 Forward approach.** Where the clear floor space is positioned for a forward approach, knee and toe clearance complying with Section 306 shall be provided. The underside of the cooktop shall be insulated or otherwise configured to protect from burns, abrasions, or electrical shock.

**1103.12.5.4.3 Parallel approach.** Where the clear floor space is positioned for a parallel approach, the clear floor space shall be centered on the appliance.

**1103.12.5.4.4 Controls.** The location of controls shall not require reaching across burners.

**1103.12.5.5 Oven.** Ovens shall comply with Section 1103.12.5.5. (10-22-12)

**1103.12.5.5.1 Clear floor space.** A clear floor space shall be provided. The oven door in the open position shall not obstruct the clear floor space for the oven.

**1103.12.5.5.2 Side-Hinged Door Ovens.** Side-hinged door ovens shall have a countertop positioned adjacent to the latch side of the oven door.

**1103.12.5.5.3 Bottom-Hinged Door Ovens.** Bottom-hinged door ovens shall have a countertop positioned adjacent to one side of the door.

**1103.12.5.5.4 Controls.** The location of controls shall not require reaching across burners.

**1103.12.5.6 Refrigerator/Freezer.** Combination refrigerators and freezers shall have at least 50 percent of the freezer compartment shelves, including the bottom of the freezer 54 inches (1370 mm) maximum above the floor when the shelves are installed at the maximum heights possible in the compartment. A clear floor space, positioned for a parallel approach to the refrigerator/freezer, shall be provided. The centerline of the clear floor space shall be offset 24 inches (610 mm) maximum from the centerline of the appliance.

**1103.13 Windows.** Operable windows shall comply with Section 1103.13. (5-22-12)

**EXCEPTIONS:**

1. Windows in kitchens shall not be required to comply with Section 1103.13.
2. Windows in bathrooms shall not be required to comply with Section 1103.13. (ed.)

**1103.13.1 Natural ventilation.** Operable windows required to provide natural ventilation shall comply with Sections 309.2 and 309.3.

**1103.13.2 Emergency escape.** Operable windows required to provide an emergency escape and rescue opening shall comply with Section 309.2.

**1103.14 Storage Facilities.** Where storage facilities are provided, at least one of each type shall comply with Section 905.

**EXCEPTION:** Kitchen cabinets shall not be required to comply with Section 1103.14.

**1104 Type B Units**

**1104.1 General.** Type B units shall comply with Section 1104.

**1104.1.1. Clear Floor Space.** The clear floor space shall be 48 inches (1220 mm) minimum in length and 30 inches (760 mm) minimum in width. (3-13L-12 PC9)

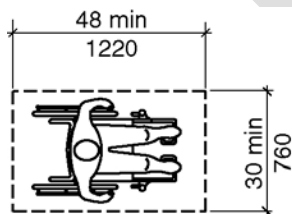


Figure 1104.1.1 – Clear floor space for Type B units

~~1104.1.2 Alcoves.~~—(ed.)

~~1104.1.3 Forward reach unobstructed.~~—(ed.)

**1104.1.2. Mailboxes.** Mailboxes serving Type B dwelling units shall be permitted an unobstructed side reach range at 54 inches (1370 mm) maximum above the floor. (3-13L-12 PC9)



**~~1104.1.5. Parking Space Width.~~** (ed.)

**1104.2 Primary Entrance.** The **accessible** primary entrance shall be on an accessible route from public and common areas. The primary entrance shall not be to a bedroom unless it is the only entrance. (ed.)

**1104.3 Accessible Route.** Accessible routes within Type B units shall comply with Section 1104.3.

**1104.3.1 Location.** At least one accessible route shall connect all spaces and elements that are a part of the unit. Accessible routes shall coincide with or be located in the same area as a general circulation path.

**EXCEPTIONS:**

1. An accessible route is not required to unfinished attics and unfinished basements that are part of the unit.
2. One of the following is not required to be on an accessible route:
  - 2.1 A raised floor area in a portion of a living, dining, or sleeping room; or
  - 2.2 A sunken floor area in a portion of a living, dining, or sleeping room; or
  - 2.3 A mezzanine that does not have plumbing fixtures or an enclosed habitable space.

**1104.3.2 Components.** Accessible routes shall consist of one or more of the following elements: walking surfaces with a slope not steeper than 1:20, doors and doorways, ramps, elevators, and platform lifts.

**1104.4 Walking Surfaces.** Walking surfaces that are part of an accessible route shall comply with Section 1104.4.

**1104.4.1 Clear Width.** Clear width of an accessible route shall comply with Section 403.5.

**EXCEPTIONS:**

1. The clear width shall be permitted to be reduced to 32 inches (815 mm) minimum for a length of 24 inches (610 mm) maximum provided the reduced width segments are separated by segments that are 48 inches (1220 mm) minimum in length and 36 inches (915 mm) minimum in width. (3-13L-12 PC9)
2. Where an accessible route makes a 180 degree turn around an object that is less than 48 inches (1220 mm) in width, clear widths shall be 42 inches (1065 mm) minimum approaching the turn, 48 inches (1220 mm) minimum during the turn and 42 (1065 mm) inches minimum leaving the turn.
3. Where an accessible route makes a 180 degree turn around an object that is less than 48 inches (1220 mm) in width, the clear width approaching the turn and leaving the turn shall be 36 inches (915 mm) minimum Where the clear width during the turn is 60 inches (1525 mm) minimum.
4. Where an accessible route makes a 90 degree turn the clear widths approaching the turn and leaving the turn shall be 36 inches (915 mm) minimum.
5. An accessible route with a clear width less than 60 inches (1525 mm) shall provide passing spaces at intervals of 200 feet (61 m) maximum. Passing spaces shall be either a 60-inch (1525 mm) minimum by 60-inch (1525 mm) minimum space, or an intersection of two walking surfaces that provide a T-shaped turning space complying with Section 304.3.2, provided the base and arms of the T-shaped space extend 48 inches (1220 mm) minimum beyond the intersection. (ed.)

**1104.4.2 Changes in Level.** Changes in level shall comply with Section 303.

**EXCEPTION:** Where exterior deck, patio or balcony surface materials are impervious, the finished exterior impervious surface shall be 4 inches (100 mm) maximum below the floor level of the adjacent interior spaces of the unit.

**1104.5 Doors and Doorways.** Doors and doorways shall comply with Section 1104.5.

**1104.5.1 Primary Entrance Door.** The primary entrance door to the unit shall comply with Section 404.

**EXCEPTIONS:**

1. Storm and screen doors serving individual dwelling or sleeping units shall not be required to comply with Section 404.2.5. (ed.)
2. For the maneuvering clearance at swinging doors, for the front approach direction on the push side the dimension perpendicular to the door shall be 48 inches (122 mm) minimum.
3. For the maneuvering clearance at sliding and folding doors, for the front approach direction the dimension perpendicular to the door shall be 48 inches (122 mm) minimum. (3-13L-12 PC9)
4. For doorways without doors the dimension perpendicular to the doorway for the front direction shall be 48 inches (122 mm) minimum. (3-6-12 PC2) (ed.)

**1104.5.2 User Passage Doorways.** Doorways intended for user passage shall comply with Section 1104.5.2.

**Exception:** Doors that are part of a shower door assembly shall not be required to comply with this section. (10-19-12 PC1.1) (ed.)

**1104.5.2.1 Clear Width.** Doorways shall have a clear opening of 31<sup>3</sup>/<sub>4</sub> inches (810 mm) minimum. Clear opening of swinging doors shall be measured between the face of the door and stop, with the door open 90 degrees.

**1104.5.2.1.1 Double Leaf Doorways.** Where the operable parts on an inactive leaf of a double leaf doorway are located more than 48 inches (1220 mm) or less than 15 inches (380 mm) above the floor, the active leaf shall provide the clearance required by Section 1004.5.2.1.

**1104.5.2.2 Thresholds.** Thresholds shall comply with Section 303.

**EXCEPTION:** Thresholds at exterior sliding doors shall be permitted to be <sup>3</sup>/<sub>4</sub> inch (19 mm) maximum in height, provided they are beveled with a slope not steeper than 1:2.

**1104.5.2.3 Automatic Doors.** Automatic doors shall comply with Section 404.3.

**1104.6 Ramps.** Ramps shall comply with Section 405.

**1104.7 Elevators.** Elevators within the unit shall comply with Section 407, 408, or 409.

**EXCEPTIONS: In a Private Residence Elevators,** the inside dimensions of elevator cars shall provide a clear floor space of 48 inches (1220 mm) minimum in length and 36 inches (760 mm) minimum in width (ed.)

**1104.8 Platform Lifts.** Platform lifts within the unit shall comply with Section 410.

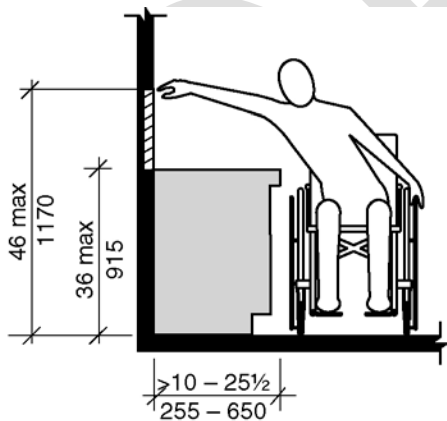
**Exception:** Platform lifts with a single door or doors on opposite ends shall provide a clear floor width of 36 inches (915 mm) minimum and a clear floor space of 48 inches (1220 mm) minimum in length and 36 inches (760 mm) in width. (3-13L-12 PC9.1) (ed.)

**1104.9 Operable Parts.** Lighting controls, electrical switches and receptacle outlets, environmental controls, electrical panelboards, and user controls for security or intercom systems shall comply with

Sections 309.3 and 1104.1.1. (3-13L-12) (3-13L-12 PC9) (ed.)

**EXCEPTIONS:**

1. Receptacle outlets serving a dedicated use.
2. In a kitchen, where two or more receptacle outlets are provided above a length of counter top that is uninterrupted by a sink or appliance, only one receptacle outlet shall be required to comply with Sections 1104.1.1 and 309.3. (10-8-12) (10-8-12 PC2)
3. In a kitchen, where a clear floor space for a parallel approach cannot be located at a counter top in a corner between appliances, receptacle outlets over the counter top shall not be required to comply with Sections 1104.1.1. and 309.3 provided that the counter top area does not exceed 9 square feet (0.835 m<sup>2</sup>) maximum. (10-8-12 PC2)
4. Floor receptacle outlets.
5. HVAC diffusers.
6. Controls mounted on ceiling fans.
7. Controls or switches mounted on appliances.
8. Plumbing fixture controls.
9. Reset buttons and shut-offs serving appliances, piping and plumbing fixtures.
10. Where redundant controls other than light switches are provided for a single element, one control in each space shall not be required to **comply with this section.** (ed.)
11. Within kitchens and bathrooms, lighting controls, electrical switches and receptacle outlets are permitted to be located over cabinets with counter tops 36 inches (915 mm) maximum in height and 25-1/2 inches (650 mm) maximum in depth.



*Figure 1104.9 Exception 12*

**1104.10 Laundry Equipment.** Washing machines and clothes dryers shall comply with Section 1104.10.

**1104.10.1 Clear Floor Space.** A clear floor space complying with Section 1104.1.1 shall be provided for each washing machine and clothes dryer. A parallel approach shall be provided for a top loading machine. A forward or parallel approach shall be provided for a front loading machine. (10-28-12) (3-13L-12) (3-13L-12 PC9)

**1104.11 Toilet and Bathing Facilities.** Toilet and bathing fixtures shall comply with Section 1104.11.

**EXCEPTION:** Fixtures on levels not required to be accessible .

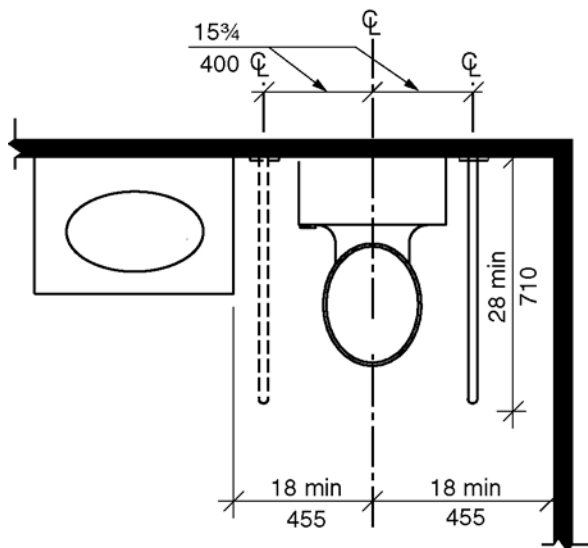
**1104.11.1 Grab Bar and Shower Seat Reinforcement.** Reinforcement shall be provided for the future installation of grab bars and shower seats at water closets, bathtubs, and shower compartments. Where walls are located to permit the installation of grab bars and seats complying with Section 604.5 at water closets; grab bars complying with Section 607.4 at bathtubs; and for grab bars and shower seats complying with Sections, 608.3, 608.2.1.3, 608.2.2.3 and 608.2.3.2 at shower compartments; reinforcement shall be provided for the future installation of grab bars and seats complying with those requirements.

**EXCEPTIONS:**

1. In a room containing only a lavatory and a water closet, reinforcement is not required provided the room does not contain the only lavatory or water closet on the accessible level of the unit.
2. At water closets reinforcement for the side wall vertical grab bar component required by Section 604.5 is not required.
3. At water closets where wall space will not permit a grab bar complying with Section 604.5.2, reinforcement for a rear wall grab bar 24 inches (610 mm) minimum in length centered on the water closet shall be provided.
4. At water closets where a side wall is not available for a 42-inch (1065 mm) grab bar complying with 604.5.1, reinforcement for a sidewall grab bar, 24 inches (610 mm) minimum in length, located 12 inches (305 mm) maximum from the rear wall, shall be provided.
5. At water closets where a side wall is not available for a 42- inch (1065 mm) grab bar complying with Section 604.5.1 reinforcement for a swing-up grab bar complying with Section 1104.11.1.1 shall be permitted.
6. At water closets where a side wall is not available for a 42-inch (1065 mm) grab bar complying with 604.5.1 reinforcement for two swing-up grab bars complying with Section 1104.11.1.1 shall be permitted to be installed in lieu of reinforcement for rear wall and side wall grab bars.
7. In shower compartments larger than 36 inches (915 mm) in width and 36 inches (915 mm) in depth reinforcement for a shower seat is not required

**1104.11.1.1 Swing-up Grab Bars.** A clearance of 18 inches (455 mm) minimum from the centerline of the water closet to any side wall or obstruction shall be provided where reinforcement for swing-up grab bars is provided. When the approach to the water closet is from the side, the 18 inches (455 mm) minimum shall be on the side opposite the direction of approach. Reinforcement shall accommodate a swing-up grab bar centered 15-3/4 inches (400 mm) from the centerline of the water closet and 28 inches (710 mm) minimum in length, measured from the wall to the end of the horizontal portion of the grab bar. Reinforcement shall accommodate a swing-up grab bar with a height in the down position of 33 inches (840 mm) minimum and 36 inches (915 mm) maximum. Reinforcement shall be adequate to resist forces in accordance with Section 609.8.

**EXCEPTION:** Where a water closet is positioned with a wall to the rear and to one side, the centerline of the water closet shall be 16 inches (405 mm) minimum and 18 inches (455 mm) maximum from the sidewall.



*Figure 1104.11.1.1 - Swing up grab bars for water closets*

**1104.11.2 Clear Floor Space.** Clear floor spaces required by Section 1104.11.3.1 (Option A) or 1104.11.3.2 (Option B) shall comply with Sections 1104.11.2 and 1104.1.1. (3-13L-12) (3-13L-12 PC9)

**1104.11.2.1 Doors.** Doors shall not swing into the clear floor space or clearance for any fixture.

**EXCEPTION:** Where a clear floor space complying with Section 1104.1.1, excluding knee and toe clearances under elements, is provided within the room beyond the arc of the door swing. (3-13L-12) (3-13L-12 PC9)

**1104.11.2.2 Knee and Toe Clearance.** Clear floor space complying with Section 1104.1.1, at fixtures shall be permitted to include knee and toe clearances complying with Section 306. (3-13L-12 PC9)

**1104.11.3 Toilet and Bathing Areas.** Either all toilet and bathing areas provided shall comply with Section 1104.11.3.1 (Option A), or one toilet and bathing area shall comply with Section 1104.11.3.2 (Option B).

**1104.11.3.1 Option A.** Each fixture provided shall comply with Section 1104.11.3.1.

**EXCEPTIONS:**

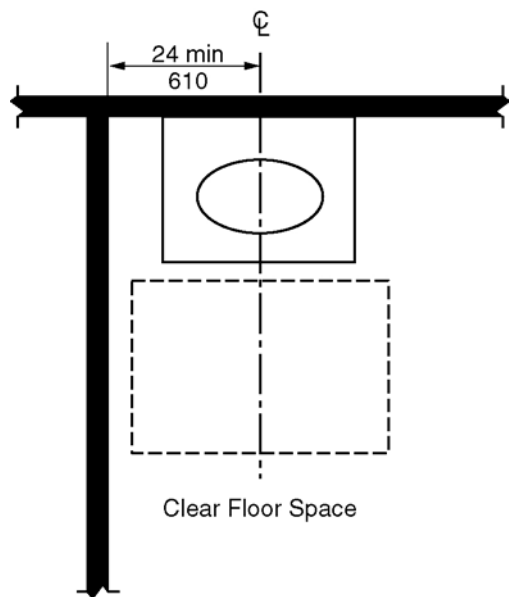
1. Where multiple lavatories are provided in a single toilet and bathing area such that travel between fixtures does not require travel through other parts of the unit, not more than one lavatory is required to comply with Section 1104.11.3.1.
2. A lavatory and a water closet in a room containing only a lavatory and water closet, provided the room does not contain the only lavatory or water closet on the accessible level of the unit.

**1104.11.3.1.1 Lavatory.** A clear floor space complying with Section 1104.1.1, positioned for a parallel approach, shall be provided at a lavatory. The clear floor space shall be centered on the lavatory. (3-13L-12) (3-13L-12 PC9)

**EXCEPTION:** A lavatory complying with Section 606.3, 606.4 and 1104.1.1 shall be permitted. Cabinetry shall be permitted under the lavatory provided the following criteria are met: (3-13L-12) (3-13L-12 PC9)

1. The cabinetry can be removed without removal or replacement of the lavatory; and

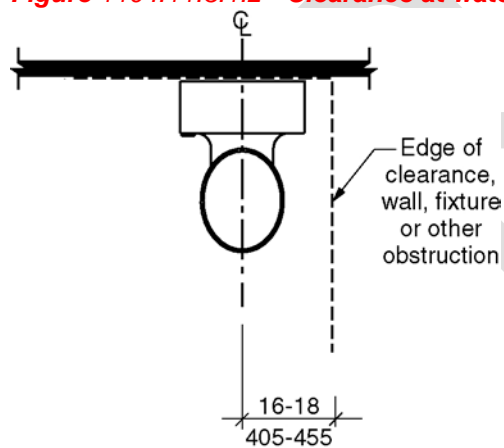
- 2. The floor finish extends under the cabinetry; and
- 3. The walls behind and surrounding the cabinetry are finished.



*Figure 1104.11.3.1.1 - Lavatory in Type B units – Option A bathrooms*

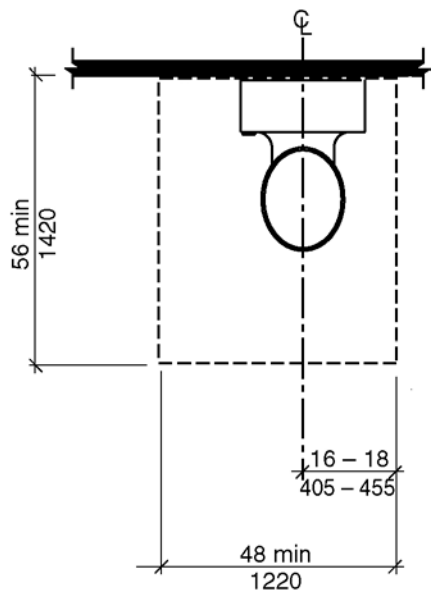
**1104.11.3.1.2 Water Closet.** The water closet shall comply with Section 1104.11.3.1.2.

*Figure 1104.11.3.1.2 - Clearance at water closets in Type B units*

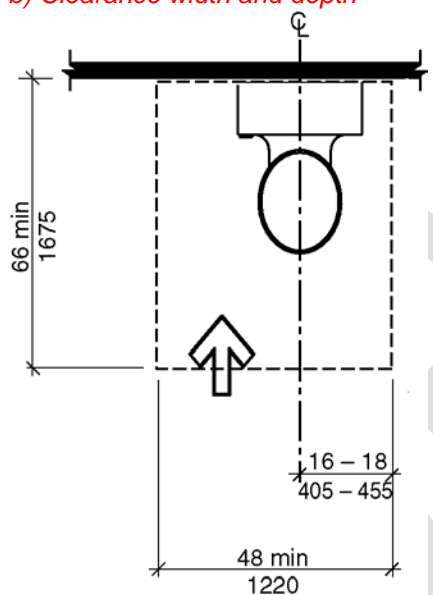


**(a) Water closet location**

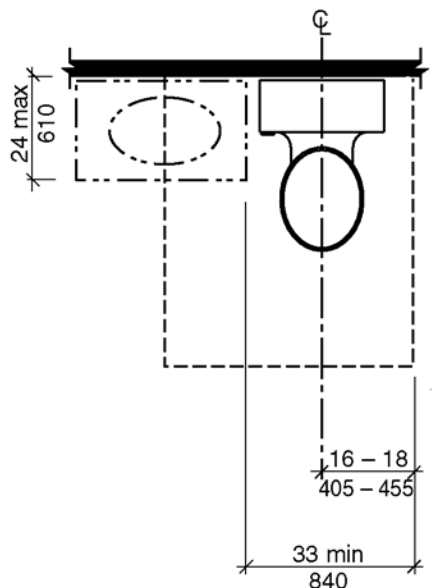
*a) Water closet location*



**(b) Clearance width and depth**  
*b) Clearance width and depth*



**(c) Increased clearance depth forward approach**  
*c) Increased clearance depth – forward approach*



**(d) Clearance with lavatory overlap**

**d) Clearance with lavatory overlap**

**1104.11.3.1.2.1 Location.** The centerline of the water closet shall be 16 inches (405 mm) minimum and 18 inches (455 mm) maximum from one side of the required clearance.

**1104.11.3.1.2.2 Clearance.** Clearance around the water closet shall comply with Sections 1104.11.3.1.2.2.1 through 1104.11.3.1.2.2.3.

**EXCEPTION:** Clearance complying with Sections 1103.11.2.4.2 through 1103.11.2.4.4.

**1104.11.3.1.2.2.1 Clearance Width.** Clearance around the water closet shall be 48 inches (1220 mm) minimum in width, measured perpendicular from the side of the clearance that is 16 inches (405 mm) minimum and 18 inches (455 mm) maximum from the water closet centerline.

**1104.11.3.1.2.2.2 Clearance Depth.** Clearance around the water closet shall be 56 inches (1420 mm) minimum in depth, measured perpendicular from the rear wall.

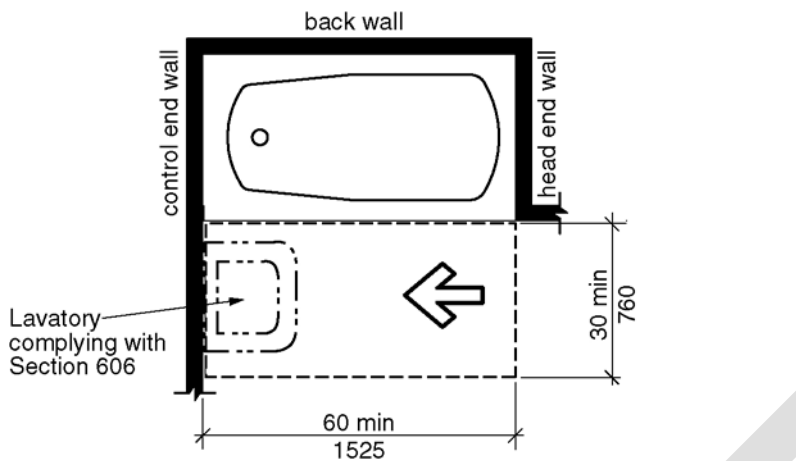
**1104.11.3.1.2.2.3 Increased Clearance Depth at Forward Approach.** Where a forward approach is provided, the clearance shall be 66 inches (1675 mm) minimum in depth, measured perpendicular from the rear wall.

**1104.11.3.1.2.2.4 Clearance Overlap.** A vanity or other obstruction 24 inches (610 mm) maximum in depth, measured perpendicular from the rear wall, shall be permitted to overlap the required clearance, provided the width of the remaining clearance at the water closet is 33 inches (840 mm) minimum.

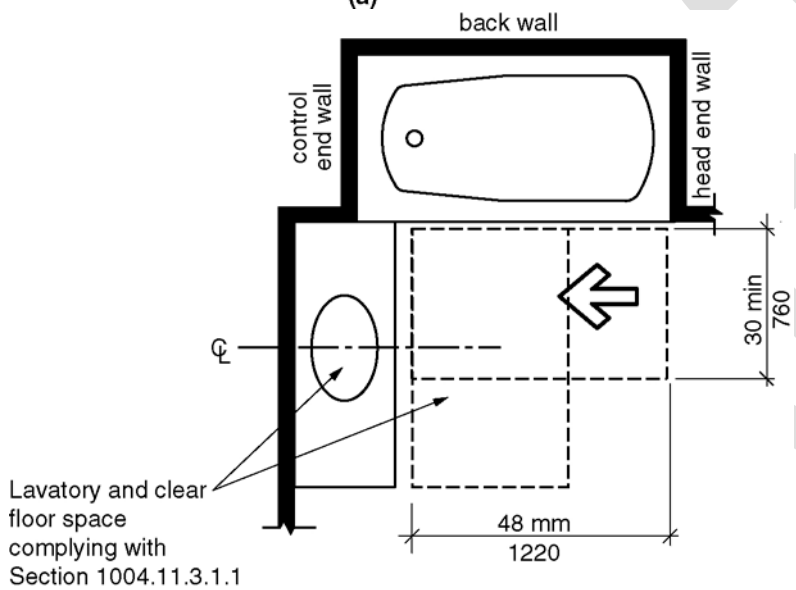
**1104.11.3.1.3 Bathing Fixtures.** Where provided, a bathtub shall comply with Section 1104.11.3.1.3.1 or 1104.11.3.1.3.2 and a shower compartment shall comply with Section 1104.11.3.1.3.3.

**1104.11.3.1.3.1 Parallel Approach Bathtubs.** A clearance 60 inches (1525 mm) minimum in length and 30 inches (760 mm) minimum in width shall be provided in front of bathtubs with a parallel approach. Lavatories complying with Section 606 shall be permitted in the clearance. A lavatory complying with Section 1104.11.3.1.1 shall be permitted at one end of the bathtub if a clearance 48 inches (1220 mm) minimum in length and 30 inches (760 mm) minimum in width is provided in front of the bathtub.





(a)



(b)

*Figure 1104.11.3.1.3.1(a&b) - Parallel approach bathtub in Type B units – Option A bathroom*

**1104.11.3.1.3.2 Forward Approach Bathtubs.** A clearance 60 inches (1525 mm) minimum in length and 48 inches (1220 mm) minimum in width shall be provided in front of bathtubs with a forward approach. A water closet and a lavatory shall be permitted in the clearance at one end of the bathtub.

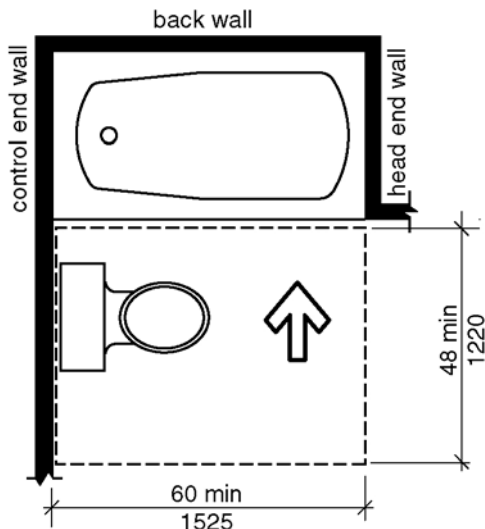


Figure 1104.11.3.1.3.2 - Forward approach bathtub in Type B units – Option A bathroom

**1104.11.3.1.3.3 Shower Compartment.** If a shower compartment is the only bathing facility, the shower compartment shall have dimensions of 36 inches (915 mm) minimum in width and 36 inches (915 mm) minimum in depth. A clearance of 48 inches (1220 mm) minimum in length, measured perpendicular from the control wall, and 30 inches (760 mm) minimum in depth, measured from the face of the shower compartment, shall be provided. (10-30-12) (ed.)

**EXCEPTIONS:**

1. A shower compartment with dimensions of 30 inches (760 mm) minimum in depth and 44 inches (1120 mm) minimum in width shall be permitted. (10-31-12)
2. A shower door assembly shall be permitted where the assembly can be removed without removal or replacement of the surrounding walls and floor to which it is affixed. (10-19-12)

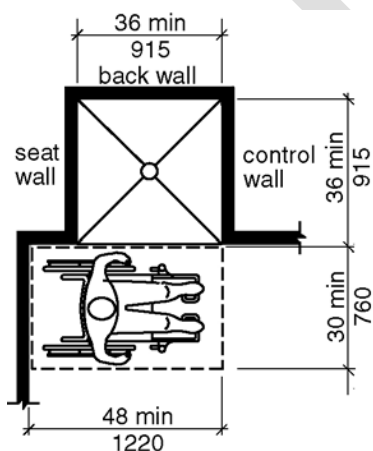
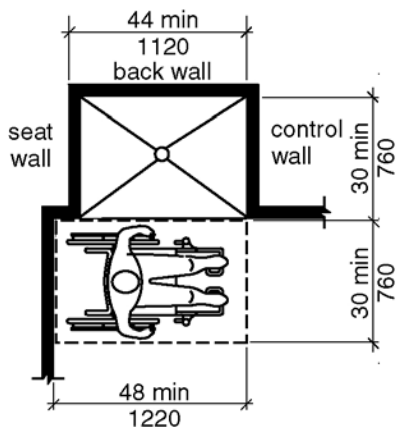


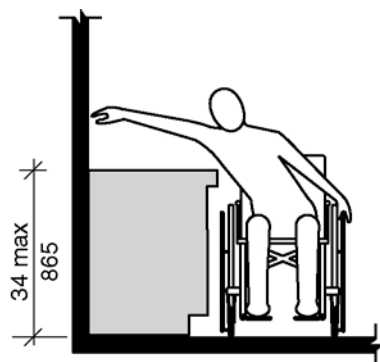
Figure 1104.11.3.1.3.3(a) - Transfer type shower compartment in Type B units



*b) exception*

**1104.11.3.2 Option B.** One of each type of fixture provided shall comply with Section 1104.11.3.2. The **accessible** fixtures shall be in a single toilet/bathing area, such that travel between fixtures does not require travel through other parts of the unit. (ed.)

**1104.11.3.2.1 Lavatory.** Lavatories shall comply with Sections 1104.11.3.1.1 and 1104.11.3.2.1.



Height

*Figure 1104.11.3.2.1 - Lavatory in Type B units – Option B bathroom*

**1104.11.3.2.1.1 Height.** The front of the lavatory shall be 34 inches (865 mm) maximum above the floor, measured to the higher of the rim or counter surface.

**1104.11.3.2.2 Water Closet.** The water closet shall comply with Section 1104.11.3.1.2.

**1104.11.3.2.3 Bathing Fixtures.** The **accessible** bathing fixture shall be a bathtub complying with Section 1104.11.3.2.3.1 or a shower compartment complying with Section 1104.11.3.2.3.2 (ed.)

**1104.11.3.2.3.1 Bathtub.** A clearance 48 inches (1220 mm) minimum in length measured perpendicular from the control end of the bathtub, and 30 inches (760 mm) minimum in width shall be provided in front of bathtubs.

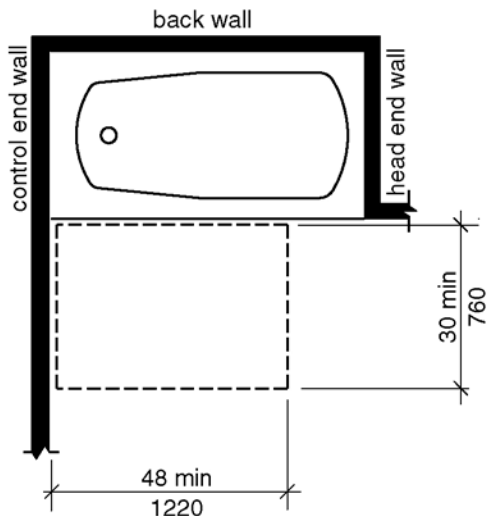


Figure 1104.11.3.2.3.1 - Bathroom clearance in Type B units – Option B bathroom

**1104.11.3.2.3.2 Shower Compartment.** A shower compartment shall comply with Section 1104.11.3.1.3.3.

**1104.12 Kitchens.** Kitchens and kitchenettes shall comply with Section 1104.12.

**1104.12.1 Clearance.** Clearance complying with Section 1104.12.1 shall be provided.

**1104.12.1.1 Minimum Clearance.** Clearance between all opposing base cabinets, counter tops, appliances, or walls within kitchen work areas shall be 40 inches (1015mm) minimum.

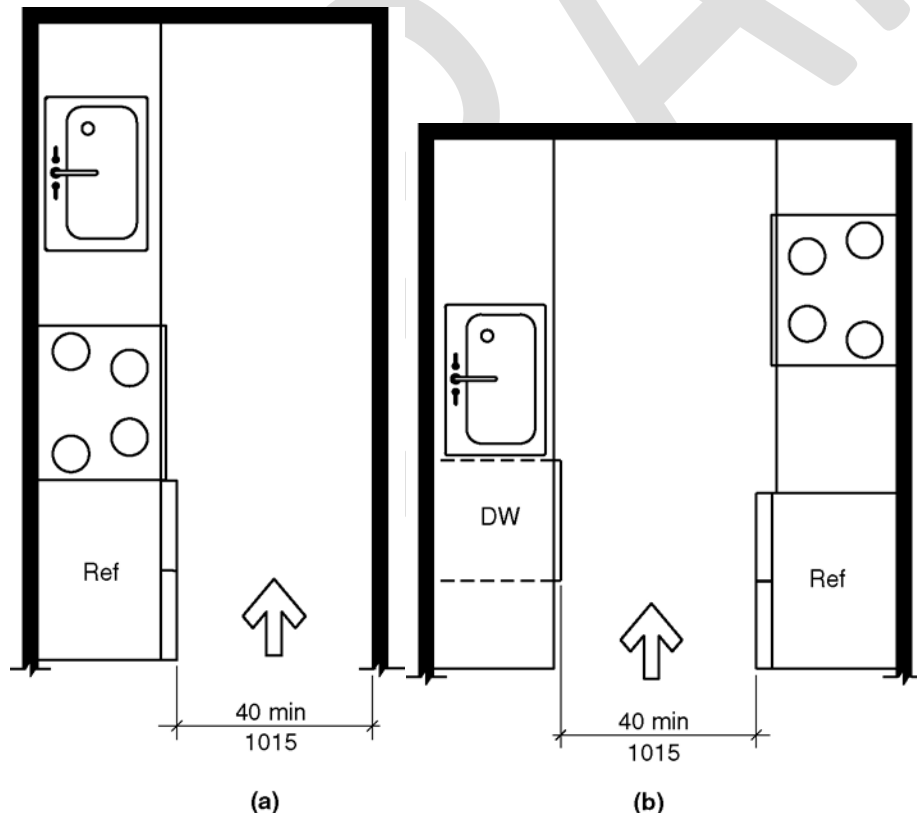
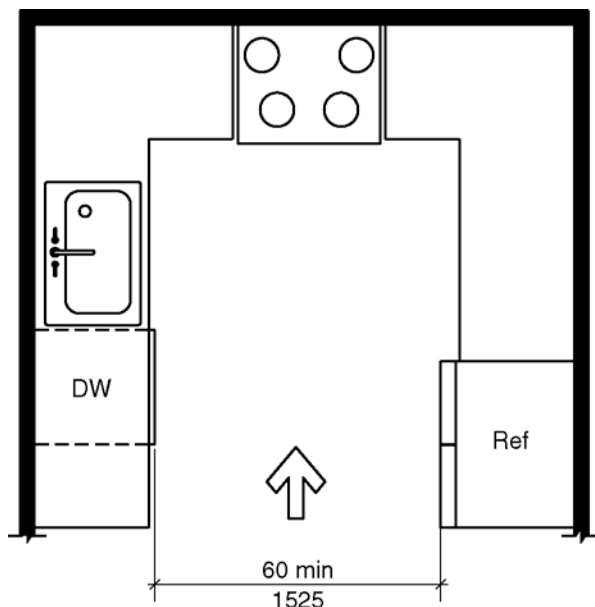


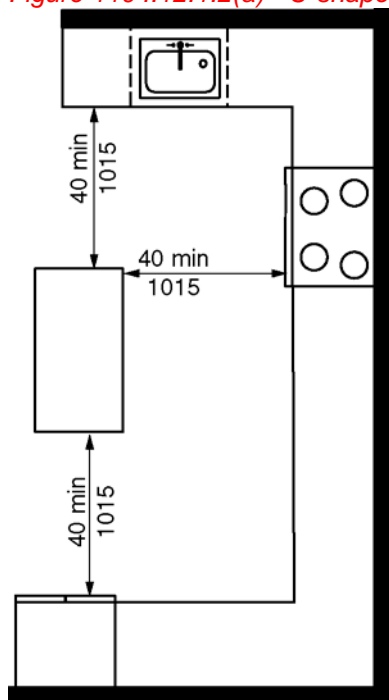
Figure 1104.12.1.1(a&b) - Minimum clearance in Type B units

**1104.12.1.2 U-Shaped Kitchens.** In kitchens with counters, appliances, or cabinets on three contiguous sides, clearance between all opposing base cabinets, countertops, appliances, or walls within kitchen work areas shall be 60 inches (1525 mm) minimum.

**EXCEPTION:** U-shaped kitchens with an island shall be permitted to comply with Section 1104.12.1.1. (8-9-12)



*Figure 1104.12.1.2(a) - U-shaped kitchen clearance in Type B units*



*b) Exception*

**1104.12.2 Clear Floor Space.** Clear floor space at appliances shall comply with Sections 1104.12.2 and 1104.1.1. (3-13L-12)

**1104.12.2.1 Sink.** A clear floor space complying with Section 1104.1.1, positioned for a parallel approach to the sink, shall be provided. The clear floor space shall be centered on the sink bowl.

**EXCEPTION:** A sink with a forward approach complying with Section 1103.12.4.1.

**1104.12.2.2 Dishwasher.** A clear floor space, positioned for a parallel or forward approach to the dishwasher, shall be provided. The dishwasher door in the open position shall not obstruct the clear floor space for the dishwasher.

**1104.12.2.3 Cooktop.** Cooktops shall comply with Section 1104.12.2.3.

**1104.12.2.3.1 Approach.** A clear floor space, positioned for a parallel or forward approach to the cooktop, shall be provided.

**1104.12.2.3.2 Forward approach.** Where the clear floor space is positioned for a forward approach, knee and toe clearance complying with Section 306 shall be provided. The underside of the cooktop shall be insulated or otherwise configured to prevent burns, abrasions, or electrical shock.

**1104.12.2.3.3 Parallel approach.** Where the clear floor space is positioned for a parallel approach, the clear floor space shall be centered on the appliance.

**1104.12.2.4 Oven.** A clear floor space, positioned for a parallel or forward approach adjacent to the oven shall be provided. The oven door in the open position shall not obstruct the clear floor space for the oven.

**1104.12.2.5 Refrigerator/Freezer.** The refrigerator/freezer shall comply with Section 1104.12.2.5. (10-35-12)

**1104.12.2.5.1 Approach.** A clear floor space positioned for a parallel or forward approach to the refrigerator/freezer shall be provided. (10-35-12)

**1104.12.2.5.2 Forward Approach.** Where the clear floor space is positioned for a forward approach, the centerline of the clear floor space shall be offset 15 inches (380 mm) maximum from the centerline of the appliance. (10-35-12)

**1104.12.2.5.3 Parallel Approach.** Where the clear floor space is positioned for a parallel approach, the centerline of the clear floor space shall be offset 24 inches (610 mm) maximum from the centerline of the appliance. (10-35-12)

**1104.12.2.6 Trash Compactor.** A clear floor space, positioned for a parallel or forward approach to the trash compactor, shall be provided.

## **1105 Type C (Visitable) Units**

**1105.1 General.** Type C (Visitable) dwelling units shall comply with Section 1105.

**1105.2 Unit Entrance.** At least one unit entrance shall be on a circulation path complying with Section 1105.5 from a public street or sidewalk, a dwelling unit driveway, or a garage.

**1105.3 Connected Spaces.** A circulation path complying with Section 1105.5 shall connect the unit entrance complying with Section 1005.2 and with the spaces specified in Section 1105.4.

**1105.4 Interior Spaces.** The entrance level shall include a toilet room or bathroom complying with Section 1005.6 and one habitable space with an area 70 square feet minimum. Where a food preparation area is provided on the entrance level, it shall comply with Section 1105.7.

**Exception:** A toilet room or bathroom shall not be required on an entrance level with less than 120 square feet of habitable space.

**1105.5 Circulation Path.** Circulation paths shall comply with Section 1105.5.

**1105.5.1 Components.** The circulation path shall consist of one or more of the following elements: walking surfaces with a slope not steeper than 1:20, doors and doorways, ramps, elevators complying with Sections 407 through 409, and wheelchair (platform) lifts complying with Section 410.

**1105.5.2 Walking Surfaces.** Walking surfaces with slopes not steeper than 1:20 shall comply with Section 303. (A117.1 8-4-16) (ed.)

**1105.5.2.1 Clear Width.** The clear width of the circulation path shall comply with Section 403.5.

**Exception:** The clear width of the circulation path shall be 36 inches (915 mm) minimum. (ed.)

**1105.5.3 Doors and Doorways.** Doors and doorways shall comply with Section 1105.5.3

**1105.5.3.1 Clear Width.** Doorways shall have a clear opening of 31-3/4 inches (810 mm) minimum. Clear opening of swinging doors shall be measured between the face of the door and stop, with the door open 90 degrees.

**1105.5.3.2 Thresholds.** Thresholds shall comply with Section 303.

**Exception:** Thresholds at exterior sliding doors shall be permitted to be 3/4 inch (19 mm) maximum in height, provided they are beveled with a slope not steeper than 1:2.

**1105.5.4 Ramps.** Ramps shall comply with Section 405.

**Exception:** Handrails, intermediate landings and edge protection shall not be required where the sides of ramp runs have a vertical drop off of 1/2 inch (13 mm) maximum within 10 inches (255 mm) horizontally of the ramp run. (ed.)

**1105.5.4.1 Clear Width.** The clear width of the circulation path shall comply with Section 403.5.

**1105.6 Toilet Room or Bathroom.** At a minimum, the toilet room or bathroom required by Section 1105.4 shall include a lavatory and a water closet. Reinforcement shall be provided for the future installation of grab bars at water closets. Clearances at the water closet shall comply with Section 1104.11.3.1.2.

**1105.7 Food Preparation Area.** At a minimum, the food preparation area shall include a sink, a cooking appliance, and a refrigerator. Clearances between all opposing base cabinets, counter tops, appliances or walls within the food preparation area shall be 40 inches (1015 mm) minimum.

**EXCEPTION:** Spaces that do not provide a cooktop or conventional range shall be permitted to provide a clearance of 36 inches (915 mm) minimum. (10-36-12)

**1105.8 Lighting Controls and Receptacle Outlets.** Receptacle outlets and operable parts of lighting controls shall be located 15 inches minimum and 48 inches maximum above the floor.

**Exception:** The following shall not be required to comply with Section 1105.8.

1. Receptacle outlets serving a dedicated use.
2. Controls mounted on ceiling fans and ceiling lights.
3. Floor receptacle outlets.
4. Lighting controls and receptacle outlets over countertops.

**1106 Units with Accessible**(ETG 12-3-15)(A117.1 8-4-16) **Communication Features** (ed.)

**1106.1 General.** Units required to have ~~accessible~~ communication features shall comply with Section 1106. (ed.)

**1106.2 Unit Smoke Detection.** Where provided, unit smoke detection shall include audible notification complying with NFPA 72 listed in Section 106.2.5.

**1106.3 Building Fire Alarm System.** Where a building fire alarm system is provided, the system wiring shall be extended to a point within the unit in the vicinity of the unit smoke detection system.

**1106.4 Visible Notification Appliances.** Visible notification appliances, where provided within the unit as part of the unit smoke detection system or the building fire alarm system, shall comply with Section 1106.4.

**1106.4.1 Appliances.** Visible notification appliances shall comply with Section 702.

**1106.4.2 Activation.** All visible notification appliances provided within the unit for smoke detection notification shall be activated upon smoke detection. All visible notification appliances provided within the unit for building fire alarm notification shall be activated upon activation of the building fire alarm in the portion of the building containing the unit.

**1106.4.3 Interconnection.** The same visible notification appliances shall be permitted to provide notification of unit smoke detection and building fire alarm activation.

**1106.4.4 Prohibited Use.** Visible notification appliances used to indicate unit smoke detection or building fire alarm activation shall not be used for any other purpose within the unit.

**1106.5 Unit Primary Entrance.** Communication features shall be provided at the unit primary entrance complying with Section 1106.5.

**1106.5.1 Notification.** A hard-wired electric doorbell shall be provided. A button or switch shall be provided on the public side of the unit primary entrance. Activation of the button or switch shall initiate an audible tone within the unit. Where visible doorbell signals are located in sleeping areas, controls shall be provided to deactivate the signal. (10-37-12)

**1106.5.2 Identification.** A means for visually identifying a visitor without opening the unit entry door shall be provided. Peepholes, where used, shall provide a minimum 180-degree range of view.

**1106.6 Site, Building, or Floor Entrance.** Where a system permitting voice communication between a visitor and the occupant of the unit is provided at a location other than the unit entry door, the system shall comply with Section 1106.6.

**1106.6.1 Public or Common-Use Interface.** The public or common-use system interface shall include the capability of supporting voice and TTY communication with the unit interface.

**1106.6.2 Unit Interface.** The unit system interface shall include a telephone jack capable of supporting voice and TTY communication with the public or common-use system interface.

**1106.7 Closed-Circuit Communication Systems.** Where a closed-circuit communication system is provided, the public or common-use system interface shall comply with Section 1106.6.1, and the unit system interface in units required to have ~~accessible~~ communication features shall comply with Section 1106.6.2. (ed.)