

# ICC A117.1 Committee Action Report

## Proposal list to the 2017 A117.1 for the 2023 edition – 2-24-2022 through 1-19-2023 Chapter 6 to 11

### Chapter 6

#### 06-01 – 2021

##### 602.4.1

**Proponent:** Kimberly Paarlberg, International Code Council

**Revise as follows:**

#### SECTION 602 DRINKING FOUNTAINS AND BOTTLE FILLING STATIONS

**602.4.1 Clear floor space.** A clear floor space complying with Section 305 positioned for a forward or side approach shall be provided.

---

**REASON:** This is somewhat of a “style” issue for the committee to consider, but it also provides clarity for the standard. While Section 305 is a “building block” section and is titled “Clear Floor Space”, since that is not a defined term, there truly is nothing to state that the clear space that this section is looking for must be of any specific size or configuration. If a designer or owner provided an 18” x 18” space similar to Section 703.3.11 or a space of any other size or configuration, how can any enforcing agency say it is not in compliance unless a specific reference or configuration is given?

This may be an item for an editorial task group to investigate. This is not the only section of the standard where this uncertainty exists. Plus, if a revision is made to only some locations, then the assumption would be that if any other section did not contain a reference that the intent was different and that a differently sized or configured space would be permitted. Unfortunately, the current standard is inconsistent. Many sections do contain the phrase “complying with Section 305” or they rely on references to other sections such as Section 309 and 309.2 which would then reference Section 305. In some sections a previous reference to Section 305 or 309 would be adequate and not every time the term “clear floor space” is used would the added reference be needed. Examples of other sections that could use this added reference are Sections 306.1, 407.2.1.3, 602.2.1 and others.

**Committee Action:** 27-0-4 As submitted

**REPORT OF HEARING:**

**Modification (if any):**

**Committee Reason:** Adding the reference to this section is editorial and add clarity. The editorial committee should investigate for consistency throughout the document.

**602.4.1-PAARLBERG.doc**

<b>Report for 06-01– 2021</b>		
<i>Committee decision: AS</i>	<i>Committee Vote at Meeting: 27-0-4</i>	<i>Committee Vote on Ballot:</i>
<b>REPORT OF HEARING:</b>		
Modification (if any):		
Committee Reason: Adding the reference to this section is editorial and add clarity. The editorial committee should investigate for consistency throughout the document.		
<b>PUBLIC COMMENT- FIRST DRAFT:</b>		
Proponent:		
Desired Action:		
Modification:		
Reason:		
<i>Committee decision: AS/AM/D</i>	<i>Committee Vote at Meeting:</i>	<i>Committee Vote on Ballot:</i>
<b>REPORT OF HEARING – FIRST DRAFT</b>		
Modification (if any):		
Committee Reason:		
<b>PUBLIC COMMENT- SECOND DRAFT:</b>		
Proponent:		
Desired Action:		
Modification:		
Reason:		
<i>Committee decision: AS/AM/D</i>	<i>Committee Vote at Meeting:</i>	<i>Committee Vote on Ballot:</i>
<b>FINAL ACTION:</b>		
Modification (if any):		
Committee Reason:		

**06-02 – 2021**  
**602.4.2**

**Proponent:** Kimberly Paarlberg, International Code Council

**Revise as follows:**

**SECTION 602**  
**DRINKING FOUNTAINS AND BOTTLE FILLING STATIONS**

**602.4.2 Controls.** Controls for bottle filling stations shall be hand operated or automatic. Hand operated controls shall comply with Section 309. Automatic controls shall allow for bottle filling within the height requirements of Section 309.3.

---

**REASON:** As currently written, automatic controls are not regulated by Section 309 and therefore are not required to be within the reach range. The provisions of Sections 602.2 and 602.3 (specifically 602.2.2 and 602.3.1) require “operable parts” for the drinking fountains to comply with Section 309 and also establish a spout height requirement. Those height limits would be required whether the drinking fountains are hand operated or automatic. The bottle filling station provisions do not contain a similar requirement and therefore it could be argued that a bottle filling station may require either a reach above 48 inches or below 15 inches in order to operate. This requirement does not specify the filler height or require it to function within the entire range of 15 to 48 inches. The intent is simply that the automatic bottle filling controls should require the filling operation to be within the minimum and maximum reach ranges.

Committee Action: 25-4-2 As Submitted

**REPORT OF HEARING:**

**Modification (if any):**

**Committee Reason:** The ability to activate automatic controls for bottle fillers by a seating person should be considered as well as their ability to manual operate controls.

**602.4.2-PAARLBERG.doc**

<b>Report for 06-02– 2021</b>		
<i>Committee decision:</i> AS	<i>Committee Vote at Meeting:</i> 25-4-2	<i>Committee Vote on Ballot:</i>
<b>REPORT OF HEARING:</b>		
Modification (if any):		
Committee Reason: The ability to activate automatic controls for bottle fillers by a seating person should be considered as well as their ability to manual operate controls.		
<b>PUBLIC COMMENT- FIRST DRAFT:</b>		
Proponent:		
Desired Action:		
Modification:		
Reason:		

<b>Report for 06-02– 2021</b>		
<i>Committee decision: AS/AM/D</i>	<i>Committee Vote at Meeting:</i>	<i>Committee Vote on Ballot:</i>
<b>REPORT OF HEARING – FIRST DRAFT</b>		
Modification (if any):		
Committee Reason:		
<b>PUBLIC COMMENT- SECOND DRAFT:</b>		
Proponent:		
Desired Action:		
Modification:		
Reason:		
<i>Committee decision: AS/AM/D</i>	<i>Committee Vote at Meeting:</i>	<i>Committee Vote on Ballot:</i>
<b>FINAL ACTION:</b>		
Modification (if any):		
Committee Reason:		



**06-03 – 2021**  
**603.2.1**

**Proponent:** Edward Steinfeld, IDEA Center, University at Buffalo, representing RESNA.

**Revise as follows:**

**SECTION 603**  
**TOILET AND BATHING ROOMS**

**603.2.1 Turning space.** A turning space shall be provided within the room. ~~The required turning spaces shall be provided~~ required within a toilet ~~compartment~~ compartments. Where provided, such turning spaces shall not be the only turning space in the room.

**REASON:** As currently written, it is not allowable to include a turning space within a compartment. This revision clarifies that they are allowed but a turning space in the room is still required if they are provided.

Committee Action:                    28-0-1                    Disapproved

**REPORT OF HEARING:**

**Modification (if any):**

**Committee Reason:** The current language meets the intent of the proponent and is clearer than the proposed text. This could be explained further in commentary.

**603.2.1-STEINFELD.doc**

<b>Report for 06-03– 2021</b>		
<i>Committee decision: D</i>	<i>Committee Vote at Meeting: 28-0-1</i>	<i>Committee Vote on Ballot:</i>
<b>REPORT OF HEARING:</b>		
Modification (if any):		
Committee Reason: The current language meets the intent of the proponent and is clearer than the proposed text. This could be explained further in commentary.		
<b>PUBLIC COMMENT- FIRST DRAFT:</b>		
Proponent:		
Desired Action:		
Modification:		
Reason:		
<i>Committee decision: AS/AM/D</i>	<i>Committee Vote at Meeting:</i>	<i>Committee Vote on Ballot:</i>
<b>REPORT OF HEARING – FIRST DRAFT</b>		
Modification (if any):		
Committee Reason:		
<b>PUBLIC COMMENT- SECOND DRAFT:</b>		
Proponent:		
Desired Action:		
Modification:		
Reason:		
<i>Committee decision: AS/AM/D</i>	<i>Committee Vote at Meeting:</i>	<i>Committee Vote on Ballot:</i>
<b>FINAL ACTION:</b>		

<b>Report for 06-03- 2021</b>
Modification (if any):
Committee Reason:

## 06-04 – 2021

### 603.3

**Proponent:** Marsha Mazz, representing United Spinal Association

**Revise as follows:**

#### SECTION 603 TOILET AND BATHING ROOMS

**603.3 Mirrors.** Where mirrors are located above lavatories, a mirror shall be located over the lavatory complying with Section 606 and shall be ~~mounted~~ installed with the bottom edge of the reflecting surface ~~40~~ 38 inches (~~1015~~ 965 mm) ~~maximum~~ above the floor. Where mirrors are located above ~~counters~~ work surfaces that do not contain lavatories, the mirror shall be mounted with the bottom edge of the reflecting surface ~~40~~ 38 inches (~~1015~~ 965 mm) maximum above the floor.

**Exception:** Other than within Accessible dwelling or sleeping units, mirrors ~~shall not be required~~ over the lavatories ~~or~~ and counters work surfaces shall not be required to comply with this section if where a mirror is located within the same toilet or bathing room and is mounted installed with the bottom edge of the reflecting surface 35 inches (890 mm) maximum above the floor.

---

**REASON:** The term “work surface” is substituted in this section for “counter”. Counters in toilet and bathing rooms are only indirectly covered – if they contain a lavatory or if one must reach across them to access an operable part. Counters with lavatories are already covered by this section. The other type of counter typically found in a toilet or bathing room is more similar to a work surface for which technical criteria is provided in Section 902.44 and where one can rest grooming products and personal belongings while combing their hair.

A common complaint among United Spinal members is that a mirror that is installed with the bottom of the reflecting surface at 40 inches min. above the floor do not reflect enough of their face and shoulders to allow for proper grooming. The front of an accessible lavatory or work surface cannot be higher than 34 inches (Sections 606.3 and 902.3). Requiring the mirror to be installed no higher than 38 inches above the floor will allow adequate space (4 inches) for a back splash or other treatment. If space is limited, designers can opt for a frameless mirror.

We revised the exception because it was confusing. As written, it exempted a mirror from being installed over the lavatory – this is not required. We revised the exception to match the intent by allowing mirrors over lavatories and counters not to be accessible if a mirror with its bottom edge no higher than 35 inches is installed elsewhere in the toilet or bathing room.

We propose changing the word “mounted” to “installed” because “mounting” is what jockeys do to horses and “installing” is what contractors do for building products. CSI Master Format Division 1 defines “install”: Unload, unpack, assemble, erect, place, anchor, apply, work to

dimension, finish, cure, connect to required services, store and protect, and similar operations required to put a product in place and make it functional and “provide”: Furnish and install completely, ready for intended use.

Committee Action: 27-2-3 Disapprove

**REPORT OF HEARING:**

**Staff note:** The word ‘maximum’ was not included in the first sentence. The proponent did not intend to delete it.

**Modification (if any):**

**Committee Reason:** The lowering of the mirror could be too tight against the backsplash. There was no information given showing that the lowering of the mirror would improve seeing in the mirror. There is the option to provide a mirror someplace else in the room.

603.3-MAZZ.doc

<b>Report for 06-04- 2021</b>		
<i>Committee decision: D</i>	<i>Committee Vote at Meeting: 27-2-3</i>	<i>Committee Vote on Ballot:</i>
<b>REPORT OF HEARING:</b>		
Modification (if any):		
Committee Reason: The lowering of the mirror could be too tight against the backsplash. There was no information given showing that the lowering of the mirror would improve seeing in the mirror. There is the option to provide a mirror someplace else in the room.		
<b>PUBLIC COMMENT- FIRST DRAFT:</b>		
Proponent:		
Desired Action:		
Modification:		
Reason:		
<i>Committee decision: AS/AM/D</i>	<i>Committee Vote at Meeting:</i>	<i>Committee Vote on Ballot:</i>
<b>REPORT OF HEARING – FIRST DRAFT</b>		
Modification (if any):		
Committee Reason:		
<b>PUBLIC COMMENT- SECOND DRAFT:</b>		
Proponent:		
Desired Action:		
Modification:		
Reason:		
<i>Committee decision: AS/AM/D</i>	<i>Committee Vote at Meeting:</i>	<i>Committee Vote on Ballot:</i>
<b>FINAL ACTION:</b>		
Modification (if any):		
Committee Reason:		

**06-05 – 2021**  
**603.5**

**Proponent:** Marsha Mazz, representing United Spinal Association

**Revise as follows:**

**SECTION 603**  
**TOILET AND BATHING ROOMS**

**603.5 Diaper changing tables.** Diaper changing tables shall comply with Sections 309 and 902. Diaper changing tables shall not be located in toilet compartments required to comply with Section 604.9.

**REASON:** A common complaint among United Spinal Association members is that baby changing tables are left in the down position and are difficult, if not impossible, to return to a closed position because their location in an accessible compartment makes it impossible to get into position to close them. Even though Section 604.3.3 prohibits a diaper changing table from overlapping the clearance around the water closet, it can still block access to the toilet when in the open position.

Committee Action: 21-9-1 As Submitted

**REPORT OF HEARING:**

**Modification (if any):**

**Committee Reason:** The baby changing tables are often left in the open position. When this is in the accessible stall, this can be an obstruction for persons with disabilities that need that space to use the water closet.

**603.5-MAZZ.doc**

<b>Report for 06-05– 2021</b>		
<b>Committee decision:</b> AS	<b>Committee Vote at Meeting:</b> 21-9-1	<b>Committee Vote on Ballot:</b>
<b>REPORT OF HEARING:</b>		
Modification (if any):		
Committee Reason: The baby changing tables are often left in the open position. When this is in the accessible stall, this can be an obstruction for persons with disabilities that need that space to use the water closet.		
<b>PUBLIC COMMENT- FIRST DRAFT:</b>		
Proponent:		
Desired Action:		
Modification:		
Reason:		
<b>Committee decision:</b> AS/AM/D	<b>Committee Vote at Meeting:</b>	<b>Committee Vote on Ballot:</b>
<b>REPORT OF HEARING – FIRST DRAFT</b>		
Modification (if any):		
Committee Reason:		
<b>PUBLIC COMMENT- SECOND DRAFT:</b>		
Proponent:		

<b>Report for 06-05– 2021</b>		
Desired Action:		
Modification:		
Reason:		
<b>Committee decision: AS/AM/D</b>	<b>Committee Vote at Meeting:</b>	<b>Committee Vote on Ballot:</b>
<b>FINAL ACTION:</b>		
Modification (if any):		
Committee Reason:		

## 06-06 – 2021

### 603.5

**Proponent:** Gene Boecker, Code Consultants, Inc.

**Add new text as follows:**

#### SECTION 603 TOILET AND BATHING ROOMS

**603.5 Diaper changing tables.** Diaper changing tables shall comply with Sections 309 and 902 and shall not be located within a toilet compartment.

---

**REASON:** It makes no sense to allow this combination. A person needing to use the water closet should not have to wait until the baby is changed and people are out of the compartment. Although the time for both activities may be somewhat similar there is no reason why the location of the diaper changing table should add to the possibility that someone is in the accessible compartment.

Conversely, it is equally unreasonable to ask for someone to stand by, holding a baby who needs changed and wait for someone to finish using the toilet compartment. This is a reasonable proposal and should be included in the standard.

Staff Note: As modified to match 06-05

Committee Action:                   23-5-2                   As Modified

#### **REPORT OF HEARING:**

**Modification (if any):**

**Replace the proposal with the following:**

**603.5 Diaper changing tables.** Diaper changing tables shall comply with Sections 309 and 902. Diaper changing tables shall not be located in toilet compartments required to comply with Section 604.9.

**Committee Reason:** The intent of this proposal and 06-05 are the same. Rather than disapprove this change based on prior action the committee voted to modify this proposal to match 06-05. See 06-05 for the committee reason for this modification.

**603.5-BOECKER.doc**

---

<b>Report for 06-06– 2021</b>		
<b>Committee decision:</b> AM	<b>Committee Vote at Meeting:</b> 23-5-2	<b>Committee Vote on Ballot:</b>
<b>REPORT OF HEARING:</b>		
Modification (if any):		
Replace the proposal with the following:		
<b>603.5 Diaper changing tables.</b> Diaper changing tables shall comply with Sections 309 and 902. <a href="#">Diaper changing tables shall not be located in toilet compartments required to comply with Section 604.9.</a>		
<b>Committee Reason:</b> The intent of this proposal and 06-05 are the same. Rather than disapprove this change based on prior action the committee voted to modify this proposal to match 06-05. See 06-05 for the committee reason for this modification.		
<b>PUBLIC COMMENT- FIRST DRAFT:</b>		
Proponent:		
Desired Action:		
Modification:		
Reason:		
<b>Committee decision:</b> AS/AM/D	<b>Committee Vote at Meeting:</b>	<b>Committee Vote on Ballot:</b>
<b>REPORT OF HEARING – FIRST DRAFT</b>		
Modification (if any):		
Committee Reason:		
<b>PUBLIC COMMENT- SECOND DRAFT:</b>		
Proponent:		
Desired Action:		
Modification:		
Reason:		
<b>Committee decision:</b> AS/AM/D	<b>Committee Vote at Meeting:</b>	<b>Committee Vote on Ballot:</b>
<b>FINAL ACTION:</b>		
Modification (if any):		
Committee Reason:		



# 06-07 – 2021

## 603.6

**Proponent:** Kimberly Paarlberg, International Code Council

**Revise text as follows:**

### SECTION 603 TOILET AND BATHING ROOMS

**603.6 Operable parts.** Operable parts on at least one towel dispensers ~~and~~ or hand dryers serving lavatories ~~complying with Section 606~~ shall comply with Table 603.6.

**TABLE 603.6  
MAXIMUM REACH DEPTH AND HEIGHT**

<b>Maximum Reach Depth</b>	0.5 inch (13 mm)	2 inches (51 mm)	5 inches (125 mm)	6 inches (150 mm)	9 inches (230 mm)	11 inches (280 mm)
<b>Maximum Reach Height</b>	48 inches (1220 mm)	46 inches (1170 mm)	42 inches (1065 mm)	40 inches (1015 mm)	36 inches (915 mm)	34 inches (865 mm)

---

**REASON:** The intent of this proposal is a coordination between this requirement typical minimum requirements in a toilet room.

Table 603.6 effectively does not allow for a towel dispenser or hand dryer to be located over a counter. Best/common design practice is to now make all lavatories in a bathroom comply with Section 606. By changing this required to say at least one towel dispense and hand dryers has to meet the reach depths, that allows for other towel dispensers to be located over the counters. Thus Little People of America will always have access to at least one, and other towel dispensers can be located over the lavatories. This would be consistent with the typical requirement for 'at least one' of other items in the toilet room. This would also allow for the reach in style of hand dryers is there was an accessible feature in the room (which I do not know how to make accessible). There is even a kind of hand dryer now that is in the lavatory.



Example of one towel dispenser meeting table and one not.



Example of reach in hand dryer.



Hand dryer in the lavatory.

Committee Action: 28-1-0 Disapproved

**REPORT OF HEARING:**

**Modification (if any):**

**Committee Reason:** This proposal an 06-08 are addressing similar issues. See the committee reason for 06-08.

**603.6-PAARLBERG.doc**

<b>Report for 06-07– 2021</b>		
<b>Committee decision:</b> D	<b>Committee Vote at Meeting:</b> 28-1-0	<b>Committee Vote on Ballot:</b>
<b>REPORT OF HEARING:</b>		
Modification (if any):		
Committee Reason: This proposal an 06-08 are addressing similar issues. See the committee reason for 06-08.		
<b>PUBLIC COMMENT- FIRST DRAFT:</b>		
Proponent:		
Desired Action:		
Modification:		
Reason:		
<b>Committee decision:</b> AS/AM/D	<b>Committee Vote at Meeting:</b>	<b>Committee Vote on Ballot:</b>
<b>REPORT OF HEARING – FIRST DRAFT</b>		
Modification (if any):		

<b>Report for 06-07- 2021</b>		
Committee Reason:		
<b>PUBLIC COMMENT- SECOND DRAFT:</b>		
Proponent:		
Desired Action:		
Modification:		
Reason:		
<b>Committee decision: AS/AM/D</b>	<b>Committee Vote at Meeting:</b>	<b>Committee Vote on Ballot:</b>
<b>FINAL ACTION:</b>		
Modification (if any):		
Committee Reason:		

**06-08 – 2021**  
**603.6**

**Proponent:** Kyle Thompson, Plumbing Manufacturers International (PMI)

**Revise as follows:**

**SECTION 603**  
**TOILET AND BATHING ROOMS**

**603.6 Operable parts.** Operable parts on one towel dispensers ~~and~~ or one hand dryers in each toilet or bathing room ~~servicing lavatories complying with Section 606~~ shall comply with Table 603.6.

**TABLE 603.6**  
**MAXIMUM REACH DEPTH AND HEIGHT**

<b>Maximum Reach Depth</b>	0.5 inch (13 mm)	2 inches (51 mm)	5 inches (125 mm)	6 inches (150 mm)	9 inches (230 mm)	11 inches (280 mm)
<b>Maximum Reach Height</b>	48 inches (1220 mm)	46 inches (1170 mm)	42 inches (1065 mm)	40 inches (1015 mm)	36 inches (915 mm)	34 inches (865 mm)

**REASON:** This proposed change clarifies that only one towel dispenser or hand dryer must meet the requirements of the table. The current text could apply that every towel dispenser or hand dryer in a toilet or bathing room must comply with Table 603.6. This would be consistent with the other accessible requirements for plumbing fixtures and fixture fittings in a public bathroom.

Committee Action:                    27-3-1                    Disapprove

**REPORT OF HEARING:**

**Modification (if any):**

**Committee Reason:** The committee was concerned at ‘or’ instead of ‘and’ would not require both a hand dryer and a towel dispenser if both were provided. This proposal would address the hand dryer/towel dispenser for Little People of America (who originally proposed Section/Table 603.6, but it would not address the requirements for the hand dryer/towel dispenser for persons in a wheelchair using the accessible lavatory.

**603.6-THOMPSON.doc**

<b>Report for 06-08– 2021</b>		
<i>Committee decision: D</i>	<i>Committee Vote at Meeting: 27-3-1</i>	<i>Committee Vote on Ballot:</i>
REPORT OF HEARING:		

<b>Report for 06-08– 2021</b>		
Modification (if any):		
Committee Reason: The committee was concerned at 'or' instead of 'and' would not require both a hand dryer and a towel dispenser if both were provided. This proposal would address the hand dryer/towel dispenser for Little People of America (who originally proposed Section/Table 603.6, but it would not address the requirements for the hand dryer/towel dispenser for persons in a wheelchair using the accessible lavatory.		
<b>PUBLIC COMMENT- FIRST DRAFT:</b>		
Proponent:		
Desired Action:		
Modification:		
Reason:		
<b>Committee decision: AS/AM/D</b>	<b>Committee Vote at Meeting:</b>	<b>Committee Vote on Ballot:</b>
<b>REPORT OF HEARING – FIRST DRAFT</b>		
Modification (if any):		
Committee Reason:		
<b>PUBLIC COMMENT- SECOND DRAFT:</b>		
Proponent:		
Desired Action:		
Modification:		
Reason:		
<b>Committee decision: AS/AM/D</b>	<b>Committee Vote at Meeting:</b>	<b>Committee Vote on Ballot:</b>
<b>FINAL ACTION:</b>		
Modification (if any):		
Committee Reason:		

# 06-09 – 2021

## 603.6

**Proponent:** Gene Boecker, Code Consultants, Inc.

**Revise as follows:**

### SECTION 603 TOILET AND BATHING ROOMS

**603.6 Operable parts.** Operable parts and openings on towel dispensers and hand dryers serving lavatories complying with Section 606 shall comply with Table 603.6. Openings on seat cover dispensers serving accessible water closets complying with Section 604 shall be located within the reach ranges in accordance with Section 308.

**TABLE 603.6  
MAXIMUM REACH DEPTH AND HEIGHT**

<b>Maximum Reach Depth</b>	0.5 inch (13 mm)	2 inches (51 mm)	5 inches (125 mm)	6 inches (150 mm)	9 inches (230 mm)	11 inches (280 mm)
<b>Maximum Reach Height</b>	48 inches (1220 mm)	46 inches (1170 mm)	42 inches (1065 mm)	40 inches (1015 mm)	36 inches (915 mm)	34 inches (865 mm)

**REASON:** Sometimes there are no parts of accessible elements that are “operable” so “openings for access to” is included in the sentence. Typically, paper towel dispensers have no operable parts; only the place where the towel is extracted from the dispenser.

Seat cover dispensers are added to this list since that are also elements provided within toilet rooms that should be within reach range. And, like paper towel dispensers, they require grasping and pulling to extract the seat cover from the dispenser. Therefore, they should be regulated the same as any other, similar dispenser.

The phrase “serving lavatories” isn’t needed and could be counterproductive. How can a person know if the hand dryer is serving a lavatory? It is it serving a kitchen sink the need is the same. If it is serving some other function, then it is not a hand dryer. This also eliminates the confusion for what to do when the diaper changing table has a paper towel dispenser associated with it. It too should be within reach range.

The exception is added because the reach range provisions are primarily for wheelchair concerns and the wheelchair accessible compartment affords those needs. Also, the seat cover dispenser is often located on the rear wall of the ambulatory compartment because there is so little other available real estate within the compartment for things to be located.

Committee Action: 24-1-0 Disapproved

**REPORT OF HEARING:**

**Modification (if any):**

**Committee Reason:** This section is for toilet and bathing rooms. The requirement for seat covers is referencing toilet stalls, so this issue should addressed there or be applicable to single occupant toile rooms and stalls. This could be read to be the entire opening instead of just where you pull out the paper. This could be read to include all openings – including the mechanism to fill these dispensers.

603.6-BOECKER.doc

<b>Report for 06-09– 2021</b>		
<i>Committee decision: D</i>	<i>Committee Vote at Meeting: 24-1-0</i>	<i>Committee Vote on Ballot:</i>
<b>REPORT OF HEARING:</b>		
Modification (if any):		
Committee Reason: This section is for toilet and bathing rooms. The requirement for seat covers is referencing toilet stalls, so this issue should addressed there or be applicable to single occupant toile rooms and stalls. This could be read to be the entire opening instead of just where you pull out the paper. This could be read to include all openings – including the mechanism to fill these dispensers.		
<b>PUBLIC COMMENT- FIRST DRAFT:</b>		
Proponent:		
Desired Action:		
Modification:		
Reason:		
<i>Committee decision: AS/AM/D</i>	<i>Committee Vote at Meeting:</i>	<i>Committee Vote on Ballot:</i>
<b>REPORT OF HEARING – FIRST DRAFT</b>		
Modification (if any):		
Committee Reason:		
<b>PUBLIC COMMENT- SECOND DRAFT:</b>		
Proponent:		
Desired Action:		
Modification:		
Reason:		
<i>Committee decision: AS/AM/D</i>	<i>Committee Vote at Meeting:</i>	<i>Committee Vote on Ballot:</i>
<b>FINAL ACTION:</b>		
Modification (if any):		
Committee Reason:		



**06-10 – 2021**  
**603.7(New)**

**Proponent:** Marsha Mazz, representing United Spinal Association

**Add new text as follows:**

**SECTION 603**  
**TOILET AND BATHING ROOMS**

**603.7 Dispensers for Accessories.** Where provided, at least one of each type of dispenser for accessories shall be located on an accessible route and the operable parts of tth dispenser shall comply with Section 309.

**REASON:** We are proposing to add this new section to address dispensers typically provided in toilet and bathing rooms, such as those for feminine hygiene or other products for personal care. In our work, surveying properties for compliance with ICC A117.1, we find that installers frequently overlook accessibility to these amenities.

**Committee Action:** 24-4-3 As Submitted

**REPORT OF HEARING:**

**Modification (if any):**

**Committee Reason:** This new section to address dispensers typically provided in toilet and bathing rooms and what must be accessible.

**603.7-MAZZ.doc**

<b>Report for 06-10- 2021</b>		
<b>Committee decision: AS</b>	<b>Committee Vote at Meeting: 24-4-3</b>	<b>Committee Vote on Ballot:</b>
<b>REPORT OF HEARING:</b>		
Modification (if any):		
Committee Reason: This new section to address dispensers typically provided in toilet and bathing rooms and what must be accessible.		
<b>PUBLIC COMMENT- FIRST DRAFT:</b>		
Proponent:		
Desired Action:		
Modification:		
Reason:		
<b>Committee decision: AS/AM/D</b>	<b>Committee Vote at Meeting:</b>	<b>Committee Vote on Ballot:</b>
<b>REPORT OF HEARING – FIRST DRAFT</b>		
Modification (if any):		
Committee Reason:		
<b>PUBLIC COMMENT- SECOND DRAFT:</b>		
Proponent:		
Desired Action:		
Modification:		
Reason:		
<b>Committee decision: AS/AM/D</b>	<b>Committee Vote at Meeting:</b>	<b>Committee Vote on Ballot:</b>
<b>FINAL ACTION:</b>		
Modification (if any):		
Committee Reason:		



# 06-11 – 2021

## 603.7(New)

**Proponent:** Gene Boecker, Code Consultants, Inc.

**Add new text as follows:**

### SECTION 603 TOILET AND BATHING ROOMS

**603.7 Benches.** Where shower rooms include space for changing clothes, accessible shower rooms shall include a bench complying with Section 903. Where benches are located within shower compartments, the accessible bench shall be provided within the accessible shower compartment.

---

**REASON:** To get into a shower and back into public spaces requires changing clothes. This is why the provisions in Section 803 were created because Dressing, Fitting and Locker rooms all involve changing clothes. Unfortunately, the way the current text is written, if a group locker room is provided with a Men’s shower room and a Women’s shower room, the accessible bench can comply and be located in the locker area, outside privacy separations. The bench should be provided where other benches are provided. If there are benches in the shower room, an accessible bench should be provided in the accessible shower room or compartment.

**Committee Action:** 19-9-5 As Submitted

#### REPORT OF HEARING:

#### Modification (if any):

**Committee Reason:** Dressing rooms adjacent to shower compartments need to be addressed. There was a concern about the terms in the first sentence not being commonly understood. In the 2<sup>nd</sup> sentence the bench is outside the shower compartment, not within. The proponent needs to bring forward some revisions.

**603.7-BOECKER.doc**

Report for 06-11– 2021		
Committee decision: AS	Committee Vote at Meeting: 19-9-5	Committee Vote on Ballot:
REPORT OF HEARING:		
Modification (if any):		
Committee Reason: Dressing rooms adjacent to shower compartments need to be addressed. There was a concern about the terms in the first sentence not being commonly understood. In the 2 <sup>nd</sup> sentence the bench is outside the shower compartment, not within. The proponent needs to bring forward some revisions.		
PUBLIC COMMENT- FIRST DRAFT:		
Proponent:		
Desired Action:		
Modification:		

<b>Report for 06-11– 2021</b>		
Reason:		
<b>Committee decision: AS/AM/D</b>	<b>Committee Vote at Meeting:</b>	<b>Committee Vote on Ballot:</b>
<b>REPORT OF HEARING – FIRST DRAFT</b>		
Modification (if any):		
Committee Reason:		
<b>PUBLIC COMMENT- SECOND DRAFT:</b>		
Proponent:		
Desired Action:		
Modification:		
Reason:		
<b>Committee decision: AS/AM/D</b>	<b>Committee Vote at Meeting:</b>	<b>Committee Vote on Ballot:</b>
<b>FINAL ACTION:</b>		
Modification (if any):		
Committee Reason:		

## 06-12 – 2021

### 604.2, 604.11.2

**Proponent:** Marsha Mazz, United Spinal Association

**Revise as follows:**

#### SECTION 604

#### WATER CLOSETS AND TOILET COMPARTMENTS

**604.2 Location.** The water closet shall be located with a wall or partition to the rear and to one side. The centerline of the water closet shall be 16 inches (405 mm) minimum and 18 inches (455 mm) maximum from the side wall or partition. In addition, where a floor mounted water closet is provided, the centerline of the drain connection shall be 10 inches minimum and 14 inches maximum measured from the rear wall. Water closets located in the ambulatory accessible toilet compartments specified in Section 604.10 shall have the parallel centerline of the water closet 17 inches minimum and 19 inches maximum from the side wall or partition.

#### **604.11 Water closets and toilet compartments for children's use.**

**604.11.2 Location.** The water closet shall be located with a wall or partition to the rear and to one side. The centerline of the water closet shall be 12 inches (305 mm) minimum and 18 inches (455 mm) maximum from the side wall or partition. In addition, where a floor mounted water closet is provided, the centerline of the drain connection shall be 10 inches minimum and 14 inches maximum measured from the rear wall. Water closets located in ambulatory accessible toilet compartments specified in Section 604.10 shall be located as specified in Section 604.2.

---

**REASON:** Our Accessibility Services staff occasionally encounter a floor mounted water closet that is set far away from the back wall. Because clearances surrounding water closets are measured from the walls (Sections 604.3.1 and 604.3.2) this results in less space around the water closet available for transfer and to access to the flush control. A standard rough-in is centered 12 inches from the back wall and would result in the gap between the tank and the wall being approximately  $\frac{3}{4}$  inch. Ten and 14 inch rough-ins are sometimes provided. With a rough-in 12 inches from the back wall, an elongated bowl will extend about 30 inches from the wall (see our alternate proposal below). We believe there is sufficient flexibility in the proposed range to accommodate nearly all floor mounted installations.

We consulted with a member of the Committee representing the plumbing industry to develop this proposal. He assured us that plumbers will have no difficulty identifying the centerline of the rough-in even once the fixture is installed because it is visible in the vitreous china. However, if the committee is not comfortable with dimensioning to the centerline of the drain connection, we would accept a friendly amendment to modify the proposal as follows:

**604.2 Location.** The water closet shall be located with a wall or partition to the rear and to one side. The centerline of the water closet shall be 16 inches (405 mm) minimum and 18 inches (455 mm) maximum from the side wall or partition. In addition, where a floor mounted water

closet is provided, the front lip of the bowl shall extend a maximum of 31 inches from the rear wall. Water closets located in the ambulatory accessible toilet compartments specified in Section 604.10 shall have the parallel centerline of the water closet 17 inches minimum and 19 inches maximum from the side wall or partition.

---

## 06-12 – 2021

### 604.2, 604.11.2

**Proponent:** Kyle Thompson, Plumbing Manufacturers International (PMI)

Revise further as follows:

#### SECTION 604 WATER CLOSETS AND TOILET COMPARTMENTS

**604.2 Location.** The water closet shall be located with a wall or partition to the rear and to one side. The centerline of the water closet shall be 16 inches (405 mm) minimum and 18 inches (455 mm) maximum from the side wall or partition. In addition, where a floor mounted water closet is provided, ~~the centerline of the drain connection shall be 10 inches minimum and 14 inches~~ the back space between the water closet and rear wall shall be 2 inches (51 mm) maximum measured from the rear wall. Water closets located in the ambulatory accessible toilet compartments specified in Section 604.10 shall have the parallel centerline of the water closet 17 inches minimum and 19 inches maximum from the side wall or partition.

#### **604.11 Water closets and toilet compartments for children's use.**

**604.11.2 Location.** The water closet shall be located with a wall or partition to the rear and to one side. The centerline of the water closet shall be 12 inches (305 mm) minimum and 18 inches (455 mm) maximum from the side wall or partition. In addition, where a floor mounted water closet is provided, ~~the centerline of the drain connection shall be 10 inches minimum and 14 inches~~ the back space between the water closet and rear wall shall be 2 inches (51 mm) maximum measured from the rear wall. Water closets located in ambulatory accessible toilet compartments specified in Section 604.10 shall be located as specified in Section 604.2.

**Reason:** Though PMI in support of the intent of the original proposal and the need to maintain clearance space for accessibility in front of water closets. There are some concerns with the application of the original proposal as well as the friendly amendment suggested in the reason statement. These concerns are that rough in specifications, such as the location of the water closet drainline connection, should be included in plumbing or building codes, not within the A117.1 accessibility standard. Also, the friendly amendment suggested in the reason statement, to specify “maximum of 31 inches from the rear wall” could limit product design and may result in limiting the building owners choice of products that could be installed, regardless of the actual clearance space available in a water closet compartment.

**Committee Action:** 31-0-1 Disapproved

**REPORT OF HEARING:**

**Modification (if any):**

**Committee Reason:** The proponent moved the modification instead of the original proposal. Water closet designs vary, so there could be a floor drain or a back drain. The choice of the finish material behind the wall could be an issue. The 2” may be too limiting. This proposed modification would result in a measurement not being able to be made until the water closet was installed – too late to make major changes to the plumbing connection. The real issue is the space in front of the water closet – so approaching this way is not a good solution.

**604.2-MAZZ.doc**

<b>Report for 06-12- 2021</b>		
<b>Committee decision: D</b>	<b>Committee Vote at Meeting:</b>	<b>Committee Vote on Ballot:</b>
<b>REPORT OF HEARING:</b>		
Modification (if any):		
Committee Reason: Dressing rooms adjacent to shower compartments need to be addressed. There was a concern about the terms in the first sentence not being commonly understood. In the 2 <sup>nd</sup> sentence the bench is outside the shower compartment, not within. The proponent needs to bring forward some revisions.		
<b>PUBLIC COMMENT- FIRST DRAFT:</b>		
Proponent:		
Desired Action:		
Modification:		
Reason:		
<b>Committee decision: AS/AM/D</b>	<b>Committee Vote at Meeting:</b>	<b>Committee Vote on Ballot:</b>
<b>REPORT OF HEARING – FIRST DRAFT</b>		
Modification (if any):		
Committee Reason:		
<b>PUBLIC COMMENT- SECOND DRAFT:</b>		
Proponent:		
Desired Action:		
Modification:		
Reason:		
<b>Committee decision: AS/AM/D</b>	<b>Committee Vote at Meeting:</b>	<b>Committee Vote on Ballot:</b>
<b>FINAL ACTION:</b>		
Modification (if any):		
Committee Reason:		

## 06-13 – 2021

604.2, 604.3.1, 604.5, 604.9.6, 604.10.1, 604.11.5, 604.12(New), 607.1, 607.2, 607.9(New), 607.9.1(New), 607.9.2(New), 608.1, 608.9(New), 608.9.1(New), 608.9.2(New), 608.9.3(New), 609, 609.1, 609.2.1, 609.2.2, 609.3, 609.4, 609.4.1, 609.4.2, 609.5, 609.6, 609.7, 609.8, 609.9(New)

**Proponent:** Jake Pauls, Jake Pauls Consulting Service, representing self

**Revise as follows:**

### CHAPTER 6 PLUMBING ELEMENTS AND FACILITIES

#### SECTION 601 GENERAL

**601.1 Scope.** Plumbing elements and facilities required to be accessible by scoping provisions adopted by the administrative authority shall comply with the applicable provisions of Chapter 6.

#### SECTION 604 WATER CLOSETS AND TOILET COMPARTMENTS

**604.1 General.** Water closets and toilet compartments shall comply with Section 604. Compartments containing more than one plumbing fixture shall comply with Section 603. Wheelchair accessible compartments shall comply with Section 604.10.

**Exception:** Water closets and toilet compartments primarily for children's use shall be permitted to comply with Section 604.11 as applicable.

**604.2 Location.** The water closet shall be located with a wall or partition to the rear and to one side. The centerline of the water closet shall be 16 inches (405 mm) minimum and 18 inches (455 mm) maximum from the side wall or partition. Water closets located in ambulatory accessible toilet compartments specified in Section 604.10 shall have the centerline of the water closet 17 inches (430 mm) minimum and 19 inches (485 mm) maximum from the side wall or partition.

**Exception:** Ambulatory accessible water closets complying with Section 604.12.

#### 604.3 Clearance.

**604.3.1 Clearance width.** Clearance around a water closet shall be 60 inches (1525 mm) minimum in width, measured perpendicular from the sidewall.

**Exception:** Ambulatory accessible water closets complying with Section 604.12.

**604.5 Grab bars and stanchions.** Grab bars and stanchions for water closets shall comply with Section 609 and shall be provided in accordance with Sections 604.5.1 and 604.5.2. Grab bars



shall be provided on the rear wall and on the side wall closest to the water closet.

**Exceptions:**

1. Grab bars and stanchions shall not be required to be installed in a toilet room for a single occupant, accessed only through a private office and not for common use or public use, provided reinforcement has been installed in walls and located so as to permit the installation of grab bars complying with Section 604.5.
2. In detention or correction facilities, grab bars and stanchions shall not be required to be installed in housing or holding cells or rooms that are specially designed without protrusions for purposes of suicide prevention.
3. Ambulatory accessible water closets served by vertical stanchions complying with Section 604.12.

**604.9 Wheelchair accessible toilet compartments.**

**604.9.6 Grab bars and stanchions.** Grab bars and stanchions shall comply with Section 609. For ambulatory accessible toilet compartments, side wall grab bars complying with Section 604.5.1 located on the wall closest to the water closet, and a rear wall grab bar complying with Section 604.5.2, shall be provided.

**604.10 Ambulatory accessible toilet compartments.**

**604.10.1** Ambulatory accessible compartments shall comply with Section 604.10. Ambulatory accessible water closets shall comply with 604.12.

**Exception:** Water closets and toilet compartments primarily for children's use shall be permitted to comply with Section 604.11 as applicable.

**604.11 Water closets and toilet compartments for children's use.**

**604.11.5 Grab bars and stanchions.** Grab bars and stanchions for water closets shall comply with Section 604.5.

**604.12 Grab bars or stanchions for ambulatory accessible water closets.** A minimum of one grab bar or vertical stanchion, complying with Section 609 shall be provided in front of and to the side of the water closet such that the grab bar or stanchion center line is within 28 in (710 mm), measured horizontally, reachable distance from the center of the front of the water closet. The grab bar or vertical stanchion shall be graspable at a height, above the finished floor level, of 36 inches (915 mm) minimum and 60 inches (1525 mm) maximum. Such grab bar or stanchion shall be permitted to serve also for a required vertical grab bar or vertical stanchion, for an adjoining bathtub or shower, complying with Sections 607 or 608, provided that it is graspable at a height, above the finished floor level, of 36 inches (915 mm) minimum and 60 inches (1525 mm) maximum.

**SECTION 607  
BATHTUBS**

**607.1 General.** Bathtubs shall comply with Section 607.

**Exception:** Ambulatory accessible bathtubs shall comply with Sections 607.2, 607.8 and 607.9.

**607.2 Clearance.** A clearance in front of bathtubs extending the length of the bathtub and 30 inches (760 mm) minimum in depth shall be provided. Where a permanent seat is provided at the head end of the bathtub, the clearance shall extend 12 inches (305 mm) minimum beyond the wall at the head end of the bathtub.

**Exception:** The clearance in front of an ambulatory accessible bathtub, complying with Section 607.8, shall extend half the length, minimum, of the bathtub.

**607.9 Ambulatory Accessible Bathtubs Grab Bars or Stanchions.** One grab bar or stanchion, minimum, shall be provided on the access side or an end wall (head end or control end) adjacent to the access side in accordance with one of the options in Section 607.9.1. This grab bar or stanchion shall be usable from the clear floor space required by Section 607.2. A second grab bar or stanchion, minimum, shall be provided on the non-access side (back wall) of the bathtub in accordance one of the options in Section 607.9.2.

**607.9.1 Access side, or adjacent end, grab bar or stanchion options.** The end wall vertical grab bar shall extend from 24 inches (610 mm) maximum to 60 inches (1524 mm) minimum above the finished floor. To avoid interference between a shower curtain rod or track for an access side set of sliding doors, the vertical grab bar on one end wall shall be provided between 9 inches (230 mm) and 12 inches (305 mm) horizontally, from the centerline of the grab bar to the exterior side of the bathtub. A second set of options for the access side vertical grab bar or stanchion shall have its centerline 2 inches (50 mm) maximum, measured horizontally, inside the exterior wall to 6 inches (150 mm) outside the exterior bathtub wall. The stanchion option, shall extend from the bathroom ceiling to either the floor or, with a steel bathtub, to the bathtub rim.

**607.9.2. Non-access side grab bar or stanchion options.** A horizontal or diagonal grab bar or a horizontal stanchion shall be provided on the back wall, or non-access side of each bathtub. Grab bars shall be 36 inches (915 mm) long, minimum. The centerline of the horizontal grab bar or stanchion, as well as the lower end of a diagonal grab bar, shall be 8 inches (200 mm) minimum and 10 inches maximum above the bathtub rim. The upper end of the diagonal grab bar shall extend to 12 inches (305 mm), maximum, horizontal, to the control end wall. Diagonal grab bar slope shall be 30 degrees minimum to 60 degrees maximum to horizontal. The horizontal stanchion shall extend to each of the end walls. The horizontal grab bar shall be centered between the end walls.

**Exception:** For relatively deep bathtubs, where the required centerline height for the horizontal grab bar exceeds 30 inches (762 mm) above the adjacent finished floor elevation, this height shall be permitted to be 3 inches (76 mm), maximum, from its centerline to either the bathtub rim height or the top of the deck for the bathtub installation which can also be the base into which the grab bar is fixed.

## SECTION 608 SHOWER COMPARTMENTS

**608.1 General.** Shower compartments shall comply with Section 608.

**Exception:** Ambulatory accessible showers shall comply with Sections 608.8 and 608.9.

**608.9 Grab bar or stanchion at the access to showers.** A grab bar or stanchion shall be provided for the shower in accordance with Section 608.9.1, 608.9.2 or 608.9.3. Location dimensions in Section 608.9 are to the centerline of the grab bar or stanchion at the fixed end of its graspable tubing component.

**608.9.1 At shower exterior.** A vertical grab bar or stanchion shall be provided outside of the shower compartment, adjacent to the access opening within 28 inches (710 mm) of the center of the shower entrance opening width. The grab bar or stanchion shall extend from 24 inches (610 mm) maximum to 60 inches (1524 mm) minimum, measured vertically above the finished floor.

**608.9.2 For smaller shower interior.** For showers with interior plan dimensions, including diagonally between corners, 51 inches (1295 mm) maximum, a vertical grab bar shall be provided, interior to the shower compartment, 30 inches (762 mm) maximum, measured horizontally from the control wall on the side closest to the access opening. The grab bar shall extend from 24 inches (610 mm) maximum to 60 inches (1524 mm) minimum, measured vertically above the finished floor outside the shower.

**608.9.3 For larger shower interior.** For showers with any interior plan dimensions exceeding 51 inches (1295 mm), including diagonally between corners, a grab bar or stanchion located interior to the shower compartment shall be 28 inches (710 mm) maximum, measured horizontally to the access to the shower. If oriented vertically, the grab bar or stanchion shall extend from 24 inches (610 mm) maximum to 60 inches (1524 mm) minimum, measured vertically above the finished floor outside the shower. If oriented horizontally, the grab bar or stanchion shall have a length 36 inches (915mm) minimum at a height, measured vertically above the finished floor outside the shower, of 48 inches (1220 mm) minimum and 60 inches (1524 mm) maximum.

## **SECTION 609**

### **GRAB BARS AND STANCHIONS**

**609.1 General.** Grab bars and stanchions in toilet or bathing facilities shall comply with Section 609.

**609.2 Cross section.** Grab bars and stanchions shall have a cross section complying with Section 609.2.1 or 609.2.2.

**609.2.1 Circular cross section.** Grab bars and stanchions with a circular cross section shall have an outside diameter of 1 1/4 inches (32 mm) minimum and 2 inches (51 mm) maximum.

**609.2.2 Noncircular cross section.** Grab bars and stanchions with a noncircular cross

section shall have a cross section dimension of 2 inches (51 mm) maximum, and a perimeter dimension of 4 inches (100 mm) minimum and 4.8 inches (120 mm) maximum. Corner radius shall be 1/4 inch (6 mm) minimum.

**609.3 Spacing.** The space between the wall and the grab bar or stanchion shall be 1 1/2 inches (38 mm) minimum. The space between the grab bar or stanchion and projecting objects below and at the ends of the grab bar or stanchion shall be 1 1/2 inches (38 mm) minimum. The space between the grab bar or stanchion and projecting objects above the grab bar or stanchion shall be 12 inches (305 mm) minimum.

**Exceptions:**

1. The space between the grab bars or stanchions and shower controls, shower fittings, and other grab bars or stanchions above the grab bar or stanchion shall be permitted to be 1 1/2 inches (38 mm) minimum.
2. Recessed dispensers projecting from the wall 1/4 inch (6.4 mm) maximum measured from the face of the dispenser and complying with Section 604.7 shall be permitted within the 12-inch (305 mm) space above and the 1 1/2-inch (38 mm) spaces below and at the ends of the grab bar or stanchion.

**609.4 Position of grab bars and stanchions.**

**609.4.1 General.** Grab and stanchions shall be installed in a horizontal position, 33 inches (840 mm) minimum and 36 inches (915 mm) maximum above the floor measured to the top of the gripping surface or shall be installed as required by Items 1 through 3.

1. The lower grab bar or stanchion on the back wall of a bathtub shall comply with Section 607.4.1.1, ~~or 607.4.2.1~~ or 607.9.2.
2. Vertical grab bars and stanchions shall comply with Sections 604.5.1.2, 604.9.6, 604.12, 607.4.1.2.2, 607.4.2.2, 607.9, and 608.3.1.2 and 608.9.
3. Grab bars at water closets primarily for children's use shall comply with Section 609.4.2.

**609.4.2 Position of children's grab bars and stanchions.** At water closets primarily for children's use complying with Section 604.11, grab bars and stanchions shall be installed in a horizontal position 18 inches (455 mm) minimum and 27 inches (685 mm) maximum above the floor measured to the top of the gripping surface. A vertical grab bar or stanchion shall be mounted with the bottom of the bar or stanchion located between 21 inches (535 mm) minimum and 30 inches (760 mm) maximum above the floor and with the centerline of the bar or stanchion located between 34 inches (865 mm).

**609.5 Surface hazards.** Grab bars plus stanchions and any wall or other surfaces adjacent to grab bars and stanchions shall be free of sharp or abrasive elements. Edges shall be rounded.

**609.6 Fittings.** Grab bars and stanchions shall not rotate within their fittings.

**609.7 Installation and configuration.** Grab bars and stanchions shall be installed in any manner that provides a gripping surface at the locations specified in this standard and does not obstruct the clear floor space. Horizontal and vertical grab bars and stanchions shall be permitted to be

separate bars, a single piece bar, or combination thereof.

**609.8 Structural strength.** Allowable stresses shall not be exceeded for materials used where a vertical or horizontal force of 250 pounds (1112 N) is applied at any point on the grab bar, stanchion, fastener mounting device, or supporting structure.

**609.9 Durability in presence of water.** Grab bars and stanchions, including mountings, shall be installed and sealed, or provided with permanent drainage such as weep holes for components subject to water intrusion, to protect structural elements from moisture.

---

**REASON:**

**Preliminary Justification for Proposal on Ambulatory Accessible Toilets, Bathtubs and Showers — Submitted by Jake Pauls  
[bldguse@aol.com](mailto:bldguse@aol.com) & [www.bldguse.com](http://www.bldguse.com)**

**Preamble.** Two points to make right at the beginning.

**First**, the task of spearheading the A117 Committee consideration of usability of bathing, showering and toileting facilities, going under the label of “ambulatory accessible,” is far beyond the capability of the proponent. In his 79<sup>th</sup> year, the proponent has seen the entire range of toileting and bathing facilities in his lifetime. Indeed, the first four years of his life took place in homes that totally lacked built-in facilities for toileting, bathing and showering which now take up the second longest chapter in A117.1. Thus it is ironic that, later in life, he has seen the complete spectrum, right up to occupying (for a couple of nights) the Presidential Suite of one of the world’s largest hotel chain’s properties, in addition to enjoying Japanese toileting and bathing facilities (mixing the ultra modern with the most traditional plumbing in Japan).

**Second**, A117.1—now in its seventh decade of life (just a bit over a decade younger than the proponent)—is now being asked to address not just the visible part of the iceberg that figuratively makes up this preeminent accessibility/usability standard’s Chapter 6, but the huge part that has been mostly out of sight, below the surface with this “iceberg.” All parts of the “iceberg” are important and the proponent asks for patience on the part of his fellow A117 Committee members as they are now being asked to help determine what we should know about—and *act on*—the largely uninvestigated topic of ambulatory, bipedal, use of facilities to which we have now devoted six decades of attention to largely wheel-based access and use.

This scope change is combined with a technical expansion to include the older of the two “Points of Control” we have come to rely upon. That is recognition, in A117.1, of **stanchions** which predated grab bars—*by perhaps a century*—and which are (in the proponent’s professional opinion) often superior to grab bars in function and aesthetics.

**Foundations.** Connecting both wheeled and bipedal ambulation-based access to bathing, showering and toileting is the science and technology of ergonomics and, in a secondary way, public health. As a Certified Professional Ergonomist (like a few others on the A117 Committee) and now the longest serving representative on several ICC and NFPA committees formally representing the American Public Health Association, the proponent brings important perspectives to our (now virtual) deliberation table. These perspectives are not sufficient to achieve acceptance of this proposal. This will take a major effort.

**Possible Need for a Task Group or Work Group.** The proponent’s first recommendation is

that a task/work group be formed of a small number of interested, informed members of the Committee (and a few experts from outside the Committee) to address the foregoing change proposal and this feeble justification statement, albeit accessible and vital to all with vision—both in functional and cerebral capabilities—to move the next edition of A117 to fill an important niche.

This niche, on bathing, showering and toileting, already is mostly addressed by another ANSI standard with a safety motivation (in NFPA 101); now we need to address such facilities with a usability focus in the most widely respected ANSI standard on usability—A117.1. (*The ball is now in our court and, like in a game, we need to play with some common rules, namely those set by ANSI to avoid contradictions among standards addressing similar issues.*) NFPA adopted requirements for safety of bathtubs and showers in its 2018 editions of NFPA 101 and 5000, updating the terminology to include “stanchions” in its 2021 editions. Both NFPA and ICC-ANSI A117.1 share a concern for ambulation of facility users, the latter recognizing the a large proportion of people with disabilities are, indeed, ambulatory and the former recognizing that a significant number of people requiring safety in buildings are not ambulatory.

**Option If A117 Committee Does Nothing.** Unless ICC wishes to reference NFPA 101 in A117.1 for requirements on grab bars and stanchions for usability as well as safety, A117.1 needs to develop its own requirements covering ambulatory accessible water closets, bathtubs and showers.

**Basic Tools (Including Visual Aids).** Fortunately, the tools we will employ in this task are largely identified. The build upon basic ergonomic concepts such as anthropometry, reach capabilities, balance (as affected by location of ones Center of Mass—COM), and points of control. At the beginning of the Justification you will be asked to view a few PowerPoint presentations that provide centrally important information forming the foundation for the proposed new language for A117.1 requirements in Chapter 6, Plumbing Elements and Facilities. These were developed only in recent days and there is not yet an audio description of the images publicly available. Sincere apologies to those not able to see the images. We will work on that, collectively, in coming months as a video, with descriptive audio track, is produced on this topic.

**Related Efforts.** Note that this topic, at least of bathing and showering, is being currently addressed by three organizations in relation to several documents, that will be published in the mid 2020s. They are:

- International Code Council (for the *International Building Code* and the *International Residential Code*)
- National Fire Protection Assn. (for the *Life Safety Code* and the *NFPA Building Construction and Safety Code*)
- Canadian Commission on Building and Fire Codes (for the *National Building Code of Canada*)

**Borrowing from Other Deliberations.** The proponent of the A117.1 changes is also the lead proponent of changes to all these documents affecting the technical requirements and scoping for all occupancies (with a very few exceptions for some institutional settings). Thus this proposal for A117.1 is an amalgam of several other proposals (dating back to 2007 in the case of one co-proponent’s early proposal in Canada). This will explain any unevenness or inconsistencies (in concepts and terminology) in this proposal for A117.1. *Apologies for this.*

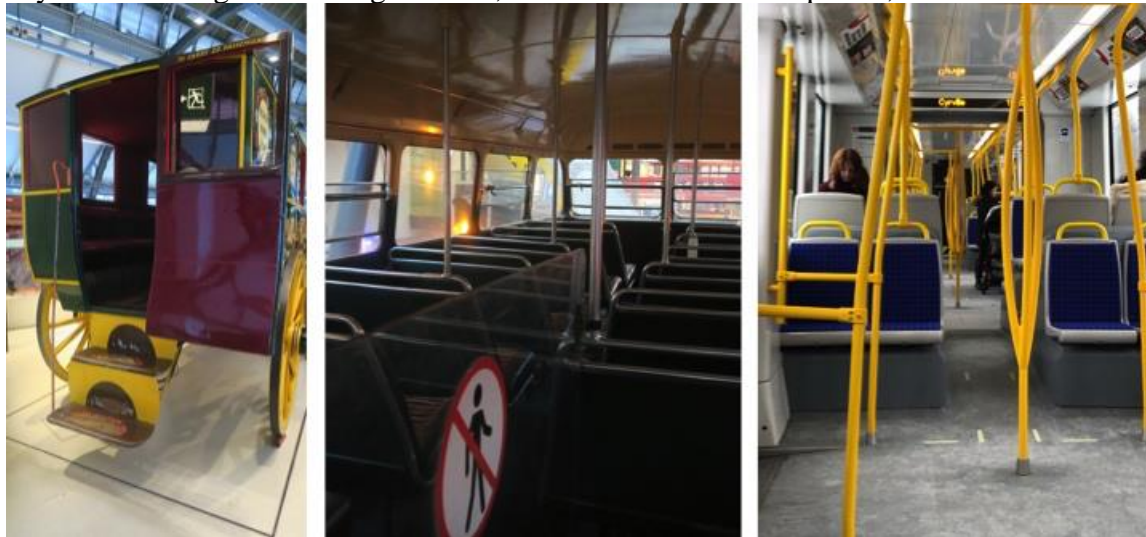
**Terminology.** We start with terminology in case the ANSI A117 Committee feels we should define what stanchions are (and perhaps what Points of Control are, including those involving



use of stanchions). For the following, the proponent borrows freely from proposals and explanatory presentations prepared for other codes/standards developing bodies in the USA and Canada in recent months of 2021.

**Stanchion.** An often vertical, tubular structure serving as a hand-grasped, point of control that is fixed between separate supporting structures, surfaces or other railings as opposed to being mounted, in cantilever fashion, on walls as occurs with conventional grab bars.

The montage of photographs below represent about two centuries of development of stanchions in the field of transportation vehicle design and use by ordinary people without any formal background in ergonomics, codes/standards development, etc.



The term “*Point of Control*” has a shorter history with the meaning most relevant to bipedal ambulation being the human extremities used for bodily support on underfoot surfaces and various handholds to facilitate safe movement; stationary erect, sitting or other posture; and the states between these activities. We have, potentially, four major points of control: two feet and two hands. Occupational rules such as for safe ladder climbing or descent spell out three points of control are prudent to maintain reasonable safety. Building codes for home stairways are largely based on two points of control in stair descent and ascent, namely one weight-bearing foot and one hand grasping a functional (as opposed to mainly decorative) railing. Our bathtub and shower designs have largely been based on a single point of control—one weight-bearing foot on either a slip resistant surface (far from certain with bathing plus other surfaces and water)—or less than one point of control if the weight-bearing foot slips.

The whole point of the major changes submitted for the A117.1 standard is to add at least one point of control to the single weight-bearing foot in entry to and exiting from a bathtub or shower enclosure. This is truly a very modest change but one that can double the points of control available to bathers. The table below sets out all the options for points of control showing how modest the change is—in merely doubling the single point of control (or less with slippery underfoot conditions) with the proposed additions to the A117.1 standard.

Number of Points of Control Via Hands or Feet	≤1	1	2	3	3-4
Standard walker for older adult with altered gait.					✓
Occupational settings with risk of worker falls from heights. Also, stairs where users can use two handrails simultaneously, one on each side.				✓	
<u>Stairs where users have only a single handrail.</u> <i>Grab bar(s) usable for bathtub/shower entry/egress.</i>			✓ ★		
Bathubs/showers with slip resistant underfoot surfaces when wet.		✓			
Bathubs/showers without slip resistant underfoot surfaces when wet, the common condition currently.	✓				

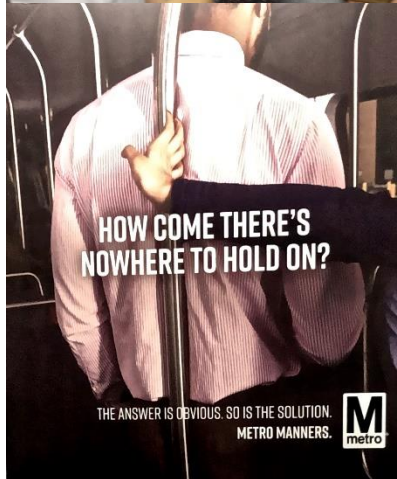
For toilet use-related (stand-to-sit and sit-to-stand) transfers, both ergonomics and scientifically-established personal preferences are for points of control for each of our two arms/hands to be available. (See the paper, Kennedy, Arcelus, Guitard Goubran, and Sveistrup [2015]. Toilet Grab-Bar Preference and Center of Pressure Deviation During Toilet Transfers in Healthy Seniors, Seniors With Hip Replacements, and Seniors Having Suffered a Stroke. *Assistive Technology: The Official Journal of RESNA*, 27:2, 78-87. The leading preference, from this study, was for two handholds on vertical points of control—e.g., stanchions or grab bars—one on each side, and at the front of the toilet; second preference was for only one such point of control (out of five options including also horizontal, swing-away and diagonal options.)

Based on both the above table and the referenced study, the changes sought in this proposal for A117.1 are modest and well warranted by science and logic that can be understood intuitively by most primates, including humans on committees such as for A117.1 on the basic issues involved with toileting, bathing and showering. The photographic series, below with a century-old trolley, provides a brief story of how effective stanchions are, even for young children encountering steps comparable in height to what is needed to surmount the wall of a typical bathtub; the height depicted here is about 16 inches (400 mm), comparable to what is found in minimum standard (e.g., IRC) permitted stairways for dwelling units—except there is no intermediate step to use as many older people need to do when using stairs (with both feet using every step). Note also the relatively puny grab bar to the woman’s left; it lacks the usefulness of the stanchion.





For a more contemporary transportation facility, albeit pre-Pandemic in crowding, see the very extensive use of stanchions, here captured on the Washington, DC, region Metro subway system. Stanchions are familiar to most people around the world for the postural control and personal space advantages they offer. They even appear in posters on such transit systems, giving social messages about these key features for our comfort and safety. The same message holds for adding stanchions to A117.1: “How come there is nowhere to hold on?”



An important lesson, from the photo sequence above, is that stanchions provide more options for placement and more options for users to choose the points of control they perceive as important to their task and safety. In other words ordinary people, even of young age, are displaying skill in ergonomics (the science and technology of how people utilize things, systems, etc. available to them to perform tasks effectively and safely).

For purposes of this A117.1 proposal, along with grab bars, it should be clear that stanchions are reliable, indeed superior, time-tested means of providing for “points of control” and they provide options for location and length that greatly exceed what conventional grab bars can provide—as they do not rely on walls from which they cantilever. (They can be *between* walls, *between floor and ceiling*, etc.) The illustration below combines all of the stanchion and conventional grab bar options set out in the accompanying detailed re-write of A117.1 Chapter 6, “Plumbing Elements and Facilities,” specifically for **Section 607.9 Ambulatory Accessible Bathtubs Grab Bars or Stanchions**.

All of the eight options are illustrated in the graphic below. The options are in two groups, three options for the one stanchion or grab bar on the non access side or back wall and five options for the one required grab bar or stanchion on the access side (front). At the front, the vertical stanchion has options for placement anywhere along the length of the bathtub (depending on fixture layout in the bathroom and where the clear, half bathtub length area (required by Section 607.2) is located—here in front of the water closet (WC). Here it is shown mid-tub length (where it is mounted on the *steel* tub rim, but could also be floor mounted for other tubs) so it also serves the WC per proposed new Section 604.12 Grab bars or stanchions for ambulatory accessible WC.



### **607.9 Ambulatory Accessible Bathtubs Grab Bars or Stanchions.**

One grab bar or stanchion, minimum, shall be provided on the access side or an end wall (head end or control end) adjacent to the access side in accordance with one of the options in Section 607.9.1. This grab bar or stanchion shall be usable from the clear floor space required by Section 607.2. A second grab bar or stanchion, minimum, shall be

provided on the non-access side (also referred to, where present, as the back wall) of the bathtub in accordance one of the options in Section 607.9.2.

Note the four options for the access side, end wall-mounted grab bar do not permit placing this grab bar where it would interfere with the installed shower curtain rod (or track) or installation of an enclosure system of sliding glass panels for example. Several inches of horizontal dimension are reserved on the end walls for such water control barriers, e.g., a shower curtain, to seal to the end walls. (The most common defect with grab placement the author saw repeatedly in his many stays in hotels around the world was having both the shower curtain and the vertical grab bar competing for the same region of the end wall. The result: during a shower, water ended up leaking to the bathroom floor, in some cases getting into end walls with moldy results.)

Here follow the proposed texts for the bathtub grab bars or stanchions with a graphic below them illustrating the full range of options, including diagonal grab bar slopes.

#### **607.9.1 Access side, or adjacent end, grab bar or stanchion options.**

The end wall vertical grab bar shall extend from 24 inches (610 mm) maximum to 60 inches (1524 mm) minimum above the finished floor. To avoid interference between a shower curtain rod or track for an access side set of sliding doors, the vertical grab bar on one end wall shall be provided between 9 inches (230 mm) and 12 inches (305 mm) horizontally, from the centerline of the grab bar to the exterior side of the bathtub. A second set of options for the access side vertical grab bar or stanchion shall have its centerline 2 inches (50 mm) maximum, measured horizontally, inside the exterior wall to 6 inches (150 mm) outside the exterior bathtub wall. The stanchion option, shall extend from the bathroom ceiling to either the floor or, with a steel bathtub, to the bathtub rim.

#### **607.9.2. Non-access side grab bar or stanchion options.**

A horizontal or diagonal grab bar or a horizontal stanchion shall be provided on the back wall, or non-access side of each bathtub. Grab bars shall be 36 inches (915 mm) long, minimum. The centerline of the horizontal grab bar or stanchion, as well as the lower end of a diagonal grab bar, shall be 8 inches (200 mm) minimum and 10 inches maximum above the bathtub rim. The upper end of the diagonal grab bar shall extend to 12 inches (305 mm), maximum, horizontal, to the control end wall. Diagonal grab bar slope shall be 30 degrees minimum to 60 degrees maximum to horizontal. The horizontal stanchion shall extend to each of the end walls. The horizontal grab bar shall be centered between the end walls.



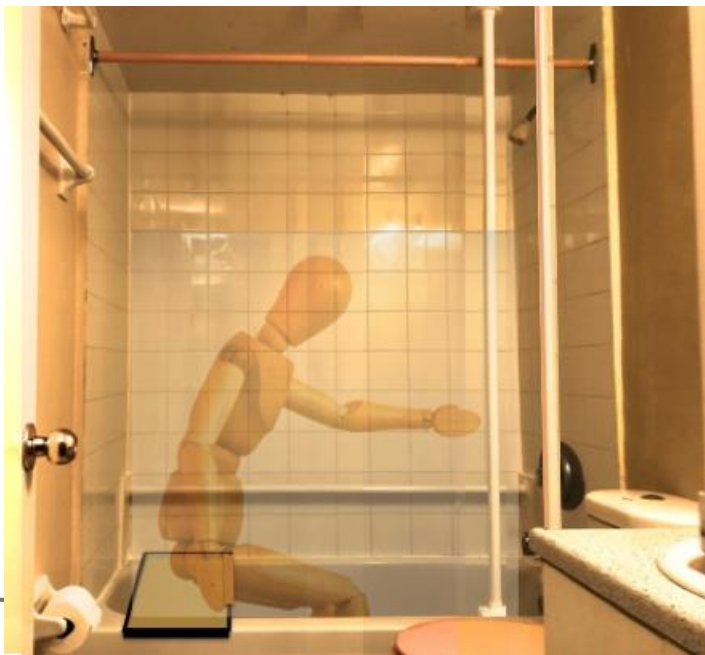
A significant aspect of the proposal for A117.1 is the introduction of stanchions, the history and ubiquity—outside of bathrooms—has already been addressed above. In the photos below, they are seen in three of the contexts at the heart of A117.1 Chapter 6, as it will be amended with the acceptance of this proposal which deals, typically with new construction. All of the examples below represent retrofit installations. Moreover, they are all retrofits in rental contexts where damage to walls is frowned upon by owners. Thus all of the examples shown of stanchions in this proposal narrative, include stanchions that can be removed (followed with the usual repainting between tenancies) without any screw holes in floors, ceilings and, most important (usually) walls. Modern RTV (Room Temperature Vulcanizing) adhesives hold these stanchions in place with holding capability meeting the 250-pound strength requirement. This adds new usefulness to A117.1 and, more importantly, to many people who develop disabilities of all types as they age and who want to “age in place” where they feel most at home. Stanchions also avoid any grab bar stigma issues as, evident especially in the two photos at the center and right sides below, the stanchions appear totally integrated with the décor, even serving as a much needed lighting pole to enhance bathroom lighting while saving energy. These stanchions all comply with the proposed requirements, completely for the contexts illustrated, from left to right: bathtub access side vertical stanchion (with a no-cost bonus of also serving as the newly required vertical stanchion for the WC). At the center is another stanchion, this one color coordinated with its surrounds and the structural supports—to the vanity—color coordinated with it (while giving extra structural support to the stanchion). At the right, the satin stainless steel stanchion matches the décor of the shower enclosure and is discretely tucked into a recess while being accessible for both entering and exiting, stepping over the 4-inch sill below the shower door. Both of the stanchions at the center and right occupy the same bathroom and both contend with the 8-foot ceiling there.





The photo at the left side demonstrates two options for a center tub-length stanchion, one affixed with RTV adhesive to a 60-year old enamel steel bathtub that has no problem with a test 330-pound, lateral load held for three hours. For newer, less rigid bathtub materials such as acrylic or fiberglass, manufacturers have raised a huge fuss over rim mounting of stanchions. They are easily appeased with the option of mounting on the adjacent floor—which is far more sturdy than the newer tubs are and has no issues with the RTV adhesive. Again, with many solid, well-performing steel bathtubs currently installed, there is much scope for both the rim- and floor-mounting options for securing stanchions in both new and existing bathrooms.

There was also some opposition—*quickly addressed*—from those concerned with the stanchion being in the way of some people with disabilities not being able to swing their fully extended legs over the tub rim when seated on a bathtub seat. Note that in the photo above, left side, there is barely room for such legs at the closely positioned WC which effectively blocks almost half the length of the tub. Notably the proposed language for A117 allows the vertical, access-side stanchion to be placed anywhere on or immediately adjacent to the entire length of the bathtub. Thus the stanchion can be placed where it suits a bather who desires to use a bathtub seat, etc.



This augmented photo illustrates the possible dilemma over such vertical stanchion placement. Is it too close to the seat; is it too far from the seat (like the water controls are), or is it just right? The proposal is open to all options on this matter (keeping in mind the value of the stanchion also serving the water closet as set out in proposed new Section 604.12 in which the performance requirement of a 28-inch

reach distance is utilized.) The 28 inches is based on a reachability analysis as well as being explained and illustrated in Appendix A to this proposal). Note also a second vertical stanchion digitally added at the vanity side serving the water closet.

**Section 608 Shower Compartments.** Focusing now on Section 608, there has been increasing evidence, especially in hotels, that bathtubs were being replaced with dedicated showers occupying the same generous space formerly taken up with a combination bathtub with shower. The showers were neither transfer type nor roll in showers, thus some new design considerations were in order for ambulatory accessible showers. The photograph which follows demonstrates what appears to be one of these conversions. This realization that showers, even in hotels, were becoming more spacious, led to the division of proposed Sections 608.9 with three options for the single required grab bar or stanchion for ambulatory users. This section needs some input from fellow A117 Committee colleagues. My effort on this is clearly preliminary but, like much else with ambulatory accessible bathroom facilities, a solution to the usability problem (along with safety issues that are the work of NFPA and other committees) is a start and is better than what exists currently.





As with the bathtub section and the water closet section, there is scope for dual utilization of stanchions especially for adjoining facilities. Thus a lot of work was done with reachability studies which is partly reflected in the accompanying Appendix A, a PowerPoint presentation prepared for the Canadians who are reaching the end of a long road, dating back to their first proposal for improved bathroom utilization of grab bars (submitted by a colleague, Dr. Nancy Edwards, an expert on falls) later augmented by my Canadian proposal in 2015 paralleling my proposals of that year to NFPA that led to changes in the 2018 NFPA 101 and 5000 on requirements for both grab bars and stanchions (first identified as “poles” in the 2018 editions). My relatively intensive work in the last year on grab bars and stanchions for bathing usability as well as safety is reflected in Appendix A.

Given the rush of dealing with multiple model codes and standards simultaneously, there is not as much time available for word-smithing and writing very detailed justifications. Appendix A makes up for a lot of that and, as has happened already in this justification, some sample pages from the presentation in Appendix A have been used in this justification that give a flavor for the analysis that has been done to treat the three facility types—water closets, bathtubs and showers—in as integrated a fashion as possible. The augmented photo below is the final example of this. It shows what appears to be a hotel bathroom conversion where the long footprint of the shower means that its entrance is possibly too far from the water closet to share the stanchion. (This is what happens when space is no longer at such a premium as it was in the humble 5 by 7 foot bathroom seen in a number of the illustrations herein and in Appendix A. Reachability becomes more of an challenge when trying to economize on number of stanchions needed.

Finally—*almost*— at least for this preliminary justification section of the proposal, a critical detail that, I hope will be accepted to no longer specify a fixed 1.5-inch clearance between a grab bar and the wall to which it is attached. Here follows the proposed change and below that is the experiment that was painfully executed in the course of addressing this matter empirically. The clearance in the photo sequence that follows was exactly 1.5 inches yet an older male adult’s hand could pass through, sustaining bruising to the back of the hand. Surely this issue of adding one word, “minimum” will be accepted as a similar change has been accepted on related topics.

**609.3 Spacing.** The space between the wall and the grab bar or stanchion shall be 1 1/2 inches (38 mm) minimum. The space between the grab bar or stanchion and projecting objects below

and at the ends of the grab bar or stanchion shall be 1 1/2 inches (38 mm) minimum. The space between the grab bar or stanchion and projecting objects above the grab bar or stanchion shall be 12 inches (305 mm) minimum.



Finally, just a brief introduction to the next page which includes a tiny portion Appendix A which is a separate, stand-alone document being provided with this proposal. There is a very strong case, based on injury evidence that there is a major distortion in the use of bathing and showering facilities by older adults who can give up frequent bathing and showering because of the real or feared dangers at worst, and hassles at best, with poorly designed and manufactured plumbing products of bathing and showering. It appears that the main reason, older adults have a reduced number of injuries associated with bathtubs and showers is not that they are reasonably safe but that people choose not to use them. This behavior differs drastically from how older adults use water closets. They have no choice but to use them and this exposure, combined with the lack of suitable points of control result in a major expansion in the number of injuries.

The page that follows, incorporating two of the slides in the PowerPoint presentation that is Appendix A, provides a preliminary examination and beginnings of an analysis which requires some further demographic study which will be done before the A117 Committee meets to discuss this and other proposals. In the meantime, you (the reader) can ponder the next page on your own.

Bottom line, understanding the impact of exposure—i.e., use—is a huge factor that A117.1 can, and must address sooner rather than later. We have to enhance all bathroom activities. ***This is an issue within the scope of A117.1 as the National Standard on Accessibility and Usability.***

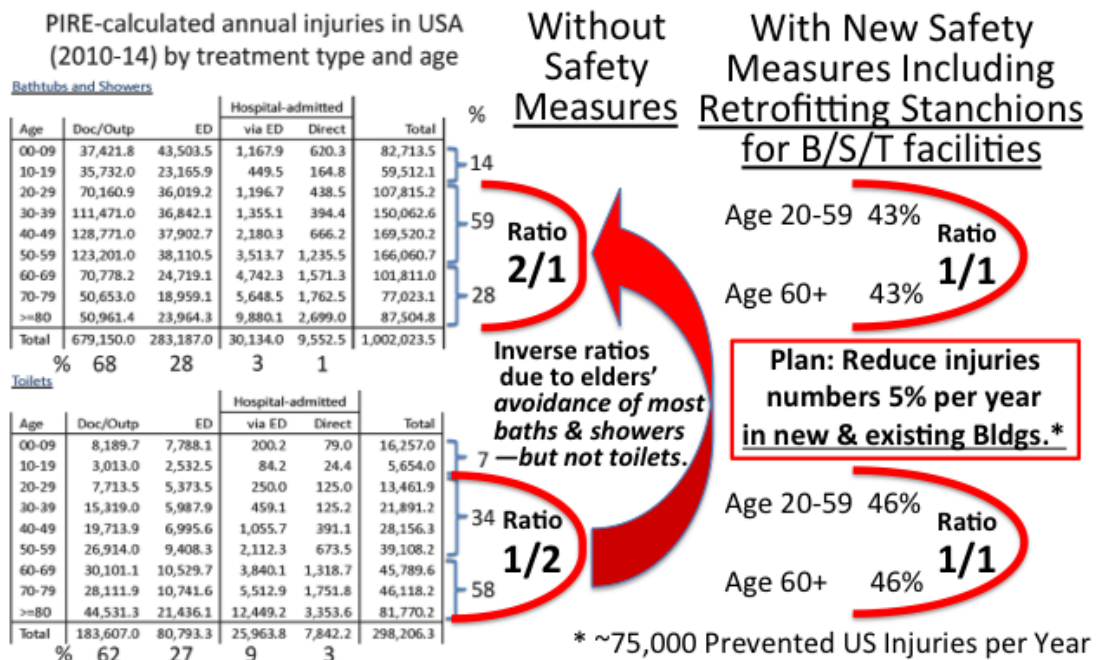


the next slide provides another important insight into the role played by elderly people’s exposure to another very serious fall risk—toilets—in bathrooms, especially in homes.

People increasingly want to “age in place” but this is needlessly more difficult and dangerous than should be the case with the hazardous trio of:

- ◆ home stairs
- ◆ Bathtubs
- ◆ toilets (water closets or commodes).

The following is more speculative than other relatively-tested ideas on bathroom usability and safety in this presentation. It is intended to further appreciate the need to study some issues and to be more proactive with improving usability and safety at very minimal cost (as illustrated in the largest section of this presentation—examples from actual bathrooms in Canada and beyond).



**Staff Note 8-9-2022 and 8-25-2022: Question divided:**

- 604 – AS 5-22-2/D 24-6-2
- 607 – AS 7-18-4/Motion to Disapprove;  
Motion to table 17-9-2 till 8/25/2022 call  
Motion to untable passed.
- Motion to table part 2 to end of chapter 6 carries with 3 votes in opposition.
- 608 –  
Modification to 608.9.1 and 608.9.3 passed 19-1-3

Motion to table parts 3 to end of chapter 6 carries with 1 vote in opposition

609 – Motion to table parts 4 to end of chapter 6 carries with 1 vote in opposition

---

## **06-13 – 2021 Replacement**

**604.2, 604.3.1, 604.5, 604.9.6, 604.10.1, 604.11.5, 604.12(New), 607.1, 607.2, 607.9(New), 607.9.1(New), 607.9.2(New), 608.1, 608.9(New), 608.9.1(New), 608.9.2(New), 608.9.3(New), 609, 609.1, 609.2.1, 609.2.2, 609.3, 609.4, 609.4.1, 609.4.2, 609.5, 609.6, 609.7, 609.8, 609.9(New)**

**Proponent:** Jake Pauls, Jake Pauls Consulting Service, representing self

**Replace and revise as follows:**

### **CHAPTER 1**

#### **SECTION 107 DEFINITIONS**

**Stanchion.** A vertical, horizontal or otherwise configured bar that provides for a power grip by one or both hands, to facilitate user ambulation and postural transitions involving sitting, standing, walking, plus stepping over obstacles and on wet underfoot surfaces. Unlike grab bars, stanchions are generally fixed between surfaces or other bars.

### **CHAPTER 6**

#### **SECTION 603 TOILET AND BATHING ROOMS**

**603.1 General.** Wheelchair accessible toilet and bathing rooms shall comply with Section 603.

**603.2 through 603.6** [unchanged]

#### **SECTION 604 WATER CLOSETS AND TOILET COMPARTMENTS**

**604.1 General.** Wheelchair accessible water closets and toilet compartments shall comply with Section 604. Compartments containing more than one plumbing fixture shall comply with Section 603. Wheelchair accessible compartments shall comply with Section 604.9. Ambulatory accessible compartments shall comply with Section ~~604.10-612~~.

**Exception:** Water closets and toilet compartments primarily for children's use shall be permitted to comply with Section 604.11 as applicable.

**Note:** Consideration of additional Editorial changes, for example to Sections 607 and 608, designating these as dealing with “wheelchair accessible” facilities is recommended, to the Editorial Subcommittee, by this proponent to differentiate such sections from the newly proposed Section 612 on “Ambulatory Accessible” facilities. The Editorial Subcommittee should also decide where it is necessary to add, after certain references to “grab bars,” the new option (for other comparable points of control), “and stanchions.”

## **SECTION 609** **GRAB BARS AND STANCHIONS**

**609.1 General.** Grab bars and stanchions in toilet or bathing facilities shall comply with Section 609.

**609.2 Cross section.** Grab bars and stanchions shall have a cross section complying with Section 609.2.1 or 609.2.2.

**609.2.1 Circular cross section.** Grab bars and stanchions with a circular cross section shall have an outside diameter of 1 1/4 inches (32 mm) minimum and 2 inches (51 mm) maximum.

**609.2.2 Noncircular cross section.** Grab bars and stanchions with a noncircular cross section shall have a cross section dimension of 2 inches (51 mm) maximum, and a perimeter dimension of 4 inches (100 mm) minimum and ~~4-8~~ 6.3 inches (~~120~~ 160 mm) maximum. Corner radius shall be 1/4 inch (6 mm) minimum.

**609.3 Spacing.** The space between the wall and the grab bar or stanchion shall be 1 1/2 inches (38 mm) minimum. The space between the grab bar or stanchion and projecting objects below and at the ends of the grab bar or stanchion shall be 1 1/2 inches (38 mm) minimum. The space between the grab bar or stanchion and projecting objects above the grab bar or stanchion shall be 12 inches (305 mm) minimum.

**Exceptions:**

1. The space between the grab bars or stanchions and shower controls, shower fittings, and other grab bars or stanchions above the grab bar or stanchion shall be permitted to be 1 1/2 inches (38 mm) minimum.
2. Recessed dispensers projecting from the wall 1/4 inch (6.4 mm) maximum measured from the face of the dispenser and complying with Section 604.7 shall be permitted within the 12-inch (305 mm) space above and the 1 1/2-inch (38 mm) spaces below and at the ends of the grab bar or stanchion.

**609.4 Position of grab bars and stanchions.**

**609.4.1 General.** Grab bars shall be installed in a horizontal position, 33 inches (840 mm) minimum and 36 inches (915 mm) maximum above the floor measured to the top of the gripping surface or shall be installed as required by Items 1 through ~~3-4~~.

1. The lower grab bar on the back wall of a bathtub shall comply with Section 607.4.1.1 or 607.4.2.1.

2. Vertical grab bars shall comply with Sections 604.5.1.2, 607.4.1.2.2, 607.4.2.2, 607.9, and 608.3.1.2.
3. Grab bars at water closets primarily for children's use shall comply with Section 609.4.2.
4. Grab bars and stanchions for ambulatory accessible toilets not in compartments, ambulatory accessible bathtubs, and ambulatory accessible shower compartments shall comply with Section 612.

**609.4.2 Position of children's grab bars.** *(No change proposed at this time.)*

**609.5 Surface hazards.** Grab bars and stanchions and any wall or other surfaces adjacent to grab bars and stanchions shall be free of sharp or abrasive elements. Edges shall be rounded with a corner radius of 1/4 inch (6 mm) minimum.

**609.6 Fittings.** Grab bars and stanchions shall not rotate within their fittings.

**609.7 Installation and configuration.** Grab bars and stanchions shall be installed in any manner that provides a gripping surface at the locations specified in this standard and does not obstruct the clear floor space. Horizontal and vertical grab bars and stanchions shall be permitted to be separate bars, a single-piece bar, or combination thereof.

**Exception:** Ambulatory accessible bathtubs and toilets complying with Section 612.3 and 612.4.1.1.

**609.8 Structural strength.** Allowable stresses shall not be exceeded for materials used where a vertical or horizontal force of 250 pounds (1112 N) is applied at any point on the grab bar, stanchion, fastener mounting device, or supporting structure.

**609.9 Durability in presence of water.** Grab bars and stanchions, including mountings, shall be installed and sealed, or provided with permanent drainage for components subject to water intrusion.

Possible further modification

**609.9 Durability in presence of water.** Grab bars and stanchions, including mountings, shall be installed ~~and sealed, to protect structural elements from~~ or provided with permanent drainage for components subject to water intrusion and moisture.

\* \* \* \* \*

**SECTION 612**  
**AMBULATORY ACCESSIBLE TOILETS, BATHTUBS AND SHOWER**  
**COMPARTMENTS**

**612.1 Scope.** Ambulatory accessible toilets, bathtubs and shower compartments shall comply with Section 612.

**612.1. General.** Grab bars and stanchions, including clearances around them, shall comply with Section 609.

**612.2. Installation Height Standards.** Installation heights for grab bars or stanchions shall comply with Section 612.2.1 for horizontal installations and Section 612.2.2 for vertical installations.

**612.2.1 Horizontal grab bars and stanchions.** For bathtubs, horizontal grab bars or stanchions shall be installed with their centerline 24 inches (610 mm) minimum and 28 inches (710 mm) maximum above the floor. In showers, horizontal grab bars and stanchions shall be installed with their centerlines located 48 inches (1220 mm) minimum and 52 inches (1320 mm) maximum above the floor.

**Exception:** Where the rim height of a bathtub exceeds 25 inches (635 mm) above the floor, the stanchion or horizontal grab bar centerline shall be 3 inches (76 mm) minimum and 6 inches (152 mm) maximum above either the bathtub rim or the top of the deck.

**612.2.2 Vertical grab bars and stanchions.** Vertical grab bars and stanchions shall be installed so as to be graspable at a height of 36 inches (915 mm) minimum and 60 inches (1525 mm) maximum above the floor.

**612.3 Water closets grab bars or stanchions.** The vertical stanchion or grab bar shall be located within an area that is both to the side of the bowl and in front of the bowl within an arc measured 24 inches (610 mm) from the front and center of the bowl.

**612.4 Bathtub grab bars or stanchions.** Grab bars or stanchions shall be provided at bathtubs on the access side complying with Sections 612.4.1 and at the non-access side complying with Section 612.4.2.

**612.4.1 Access side of bathtubs.** A clearance shall be provided adjacent to the bathtub extending 30 inches (762 mm) minimum in length and 30 inches (762 mm) in depth. A vertical grab bar or stanchion shall be provided on the access side of the bathtub, adjacent to the clearance and complying with Section 612.4.1.1, 612.4.1.2 or 612.4.1.3.

**612.4.1.1 Vertical stanchion.** A vertical stanchion shall be installed on the rim or the bathtub or on the outside of the bathtub within 4 inches (102 mm) measured horizontally from the centerline of the stanchion to the outside face of the bathtub at the stanchion.

**612.4.1.2 End wall grab bar interior of bathtub.** A vertical grab bar shall be installed on an end wall 9 inches (229 mm) minimum and 12 inches (305 mm) maximum measured horizontally from the centerline of the grab bar to the outside face of the bathtub below the grab bar.

**612.4.1.3 End wall grab bar exterior of bathtub.** A vertical grab bar shall be installed on an end wall 4 inches (102 mm) maximum measured horizontally from the centerline of the grab bar to the outside face of the bathtub below the grab bar.

**612.4.2 Non-access Side of Bathtubs.** A grab bar or stanchion shall be provided on the non-access side of the tub complying with Section 612.4.2.1, 612.4.2.2 or 612.4.2.3.

**612.4.2.1. Horizontal Grab Bar.** A horizontal grab bar shall be installed on the back wall and shall be of 36 (915 mm) minimum in length with the ends located 12 inches (305 mm) maximum from the from the head and control ends of the bathtub.

**612.4.2.2 Horizontal Stanchion.** A horizontal stanchion shall be installed between the head and control end walls.

**612.4.2.3 Diagonal Grab Bar.** The diagonal grab bar shall be installed on the back wall and shall be 36 inches (305 mm) minimum in length. Its slope shall be 30 degrees minimum to 60 degrees maximum to horizontal. The upper end shall extend to 12 inches (305 mm) maximum from the control end wall. The lower end of the diagonal grab bar shall be 3 inches (76 mm) minimum and 6 inches (152 mm) maximum above the bathtub rim.

**612.5. Shower Compartment Grab Bars and Stanchions.** For shower compartments having a diagonal dimension of 51 inches (1295 mm) maximum, a grab bar or stanchion shall be provided in accordance with Section 612.5.1, 612.5.2 or 612.5.3. For shower compartments having a diagonal dimension of greater than 51 inches (1295 mm), two grab bars or stanchions shall be provided with one in accordance with Section 612.5.1, 612.5.2 or 612.5.3 and a second grab bar or stanchion in accordance with Section 612.5.4 or 612.5.5.

**612.5.1 Horizontal Grab Bar Option.** A horizontal grab bar shall be installed with a minimum length of 24 inches (610 mm) and located inside the compartment with one end within 4 inches (100 mm) of the shower entrance opening.

**612.5.2 Vertical Grab Bar Option.** A vertical grab bar shall be installed with the grab bar centerline located within 3 inches (75 mm) of the shower entrance opening, either inside or outside the compartment.

**612.5.3 Vertical Stanchion.** A vertical stanchion shall be installed with the stanchion centerline located within 3 inches (75 mm) of the shower entrance opening, either inside or outside the compartment.

**612.5.4. Second grab bar.** A horizontal grab bar shall be provided on the back wall of the shower. The grab bar shall have its ends extending to within 12 inches (305 mm) of each end of the side walls.



**612.5.5. Second stanchion** A horizontal stanchion shall be provided on the back wall of the shower. The stanchion shall extend the full length of the back wall mounted between side walls.

**Reason statement:**

**General Background to A117.1 Proposal 06-13 Now Being Replaced and Selected Details**

A very large portion of the population, needing to use toilets, bathtubs and showers, have disabilities that still permit ambulation that ranges from fully capable to highly compromised. This is most marked with increasing age and is also manifested in missteps and falls through the entire lifespan.

Countermeasures for the injuries and further disabilities that result from falls and other incidents, are addressed in a preventative or mitigation fashion by other ANSI standards besides A117.1. However, it should be stressed that ICC ANSI A117.1 focuses on the architectural or general design and installation implications for use of essential facilities more generally. It addresses an important set of user needs.

Further use of toilets, bathtubs and showers is impacted as individual user experience with the facilities becomes increasingly problematic, difficult and consequential with time and exposure. Use and usability generally are the focus of A117.1. Maintaining and enhancing regular use of bathing and showering facilities should, for example, be as important as is regular toilet use.

With application of an expanded A117.1, all of these facilities can be made more usable, without sacrificing or complicating both voluntary and essential user exposure to the facilities by the entire population. The provisions set out in this proposal advance this objective, using comparable ergonomic expertise to that applied for decades, improving the lives of people with physical disabilities whose ambulation has been affected in the most consequential ways. The scope of affecting people's lives generally, by addressing ambulation more comprehensively, is now being expanded significantly with these initial recommendations on ambulatory accessible facilities. A comprehensive re-examination of children's use of facilities is outside of scope here.

One specific change from the original submission is that, as just noted (in the end of the prior paragraph), there was originally a minor change proposed to the first part of **609.4.2 Position of children's grab bars and stanchions**. These involved adding a few references to "stanchions" as options to grab bars, but in the revised proposal draft provided above, it was noted, "**609.4.2 Position of children's grab bars**. (*No change proposed at this time.*)" Although my personal library includes detailed anthropometric data for children as well as a copy of the landmark book, "*Ergonomics for Children*," for which I was the author invited to write the chapter on children and stairs which has some relevant information on children development and anthropometrics on matters such as capabilities with points of control, including reach, grasp height preferences, and hand grip capabilities, I was simply too busy to do further research with and beyond the *Ergonomics for Children* book which is in my Toronto office library.

Another change from the original submission was to reference tub grab bar heights relative to the floor rather than to the top of the tub rim. However, there remains, in the currently proposed text, one reference to height measured to the bathtub rim and that is for diagonal grab bars on the back wall. For these, given the option of using any grab bar slope from 30 to 60 degrees, there are some complications to the bar's height that might be further clarified at public comment stage. Diagonal bars on tub back walls are, apparently, a newer configuration in the US than they are in Canada.

Other matters where there were changes from the original proposal relate, for example, to adding exceptions for stanchions in Sections for toilets, bathtubs and showers. These did not get much support in the Work Group and the issue was better resolved by clarifying, with new (editorial) text that those few Sections could, editorially, be fixed by adding "Wheelchair Accessible" to their title headings. That would improve the Standard considerably in my opinion.

In terms of possible new requirements being added between my original submission of the Proposal and now, the addition, in my Proposal, to make the rule that grab bar edges be rounded should be improved by requiring a quarter-inch radius of rounding was made in only one of the sections of 609 where this was to be required. The second of the references to this topic occurs in 609.5, "Surface hazards" section, which I had misread to apply not to the grab bar's bar/tubing element but to the surrounding surfaces. I was told that the somewhat ambiguous wording meant both the grab and its surroundings had to meet the rounding rule which I had dealt with in 609.2.2, Noncircular cross section. During deliberations so far, there has been no objection to adding the minimum quarter inch rounding to both sections and it is clearly my hope that both sections get full public review as proper proposals and are accepted.

Related to these issues with Section 609, it would help if, *editorially*, the order of subsections be made a bit more rational keeping similar issues together. With the need to address my sweeping change in Chapter 6, including editorial cleanup, this might be appropriate for Editorial Subcommittee work later. Having already served my time on the Editorial Subcommittee, I hope to stay clear of its very important work load at this time. Other members of the A117 Committee should appreciate how valuable an education it is to serve on the editing task for the Standard.

**For much more, see the accompanying, full Reason Statement which includes highlights of pre-2022 justification materials considered by the A117 Committee, especially its Work Group on Proposal 06-13, during 2022. The Work Group on Proposal 06-13, met several times during 2022 and the work by a few of its participants, such a Kim Paarlberg and Marsha Mazz, were notable.**

**Staff note: "The accompanying, full Reason Statement" is included below.**

---

**Justification for Revised Proposal  
on Ambulatory Accessible Toilets, Bathtubs and Showers  
Submitted by Jake Pauls, BArch, CPE, HonDSc  
[bldguse@aol.com](mailto:bldguse@aol.com) & [www.bldguse.com](http://www.bldguse.com)**



December 12, 2022

**Foundations.** Connecting both wheeled and bipedal ambulation-based access to bathing, showering and toileting is the science and technology of ergonomics and, in a secondary way, public health. As a Certified Professional Ergonomist (like a few others on the A117 Committee) and now the longest serving representative on several ICC and NFPA committee formally representing the American Public Health Association, the proponent brings important perspectives to our (now virtual) deliberation table. This has taken a major group effort and more perspectives.

**Work Group Formed.** The proponent's first recommendation, made in 2021, was that a task/work group be formed of a small number of interested, informed members of the Committee (and a few experts from outside the Committee) to address the change proposal and, to a lesser extent, the justification or reason statement.

This niche, on bathing, showering and toileting, already is mostly addressed by another ANSI standard—one with a safety motivation and scope (i.e., NFPA 101). Now we need to address such facilities with a usability focus in the most widely respected ANSI standard on facility usability—A117.1. NFPA adopted requirements for safety of bathtubs and showers in its 2018 editions of NFPA 101 and 5000, updating the terminology to include “stanchions” in their 2021 editions. NFPA and the ANSI A117 Committee share a concern for ambulation of facility users, the latter recognizing that a large proportion of people with disabilities are, indeed, ambulatory and the former recognizing, decades ago, that a significant number of people requiring safety in buildings are not ambulatory.

**An Option If A117 Committee Does Nothing.** Unless ICC wishes to reference NFPA 101 in ICC A117.1 for requirements on grab bars and stanchions for usability as well as safety, the A117 Committee needs to develop its own requirements covering ambulatory accessible water closets, bathtubs and showers. (It did this for stairs decades ago.)

**Basic Tools (Including Visual Aids).** Fortunately, the tools we will employ in this task are largely identified. They build upon basic ergonomic concepts such as attention to anthropometry, including reach capabilities, plus balance (as affected by location of ones Center of Mass—COM), and points of control, especially upper body ones, etc.

**Related but Disparate Efforts.** Note that this topic, at least of bathing and showering, is being currently addressed—or *barely addressed*—in disparate ways, by three North American organizations in relation to several documents, that will be published in the 2020s. They are:

- *International Code Council* (for the *International Building Code* and the *International Residential Code*)
- *National Fire Protection Association* (for the *Life Safety Code* and the *NFPA Building Construction and Safety Code*)
- *Canadian Commission on Building and Fire Codes*, replaced on November 22, 2022 by the recently formed *Canadian Board for Harmonized Construction Codes* (CBHCC) to oversee development and adoption of the *National Building Code of Canada* (NBCC) but, apparently, with far less attention given to usability and safety of homes as well as human factors or ergonomics and public health principles generally in all new buildings.

**Borrowing from Other Deliberations.** The proponent of the A117.1 changes is (or recently has been) also a leading proponent of changes to all these documents affecting the technical requirements and scoping for all occupancies (with a very few exceptions for some institutional settings healthcare and detention/correction). Thus this proposal for A117.1 is an amalgam of several other proposals (dating back to 2007 in the case of one co-proponent’s— Dr. Nancy Edwards’—early proposal for the NBCC in Canada).

**Terminology and Implementation Criteria.** We start with terminology in case the ANSI A117 Committee feels we should define what stanchions are (and perhaps what *Points of Control* are, including especially upper body points of control making use of stanchions). For the following, the proponent borrows freely from proposals and explanatory presentations prepared not only for other codes/standards- developing bodies in North America, but for world conferences on state-of-the-art ergonomics plus applications where usability is currently poorly provided. Before addressing stanchions (as well as grab bars), we need to understand “points of control.”

**Point of Control** (not being proposed as a definition for A117.1 as this requires more work and more expert input). The securely maintained contacts, including with a power grip by ones hand, on a stanchion, grab bar or handrail and the placing of ones foot on a slip-resistant, underfoot surface that permits efficient, comfortable and safe ambulation on a (near) level surface, climbing over an obstacle (e.g., a bathtub rim), and ascending or descending to a higher or lower stair tread.

Although I am not able to provide an official definition of the term “Point of Control” (which is likely in one of the reference handbooks in my Toronto office library), there is a definition for “power grip”—which is what we hope to achieve for a “point of control.” The definition “**Power Grip**” is a “prehensile grasp by either hand, with the thumb opposing the fingers, of an object to control or manipulate it.” (Thompson, D.A. *et al.* 2005. A guide to forensic human factors terminology. In: Noy, Y.I. and Karwowski, W. (Eds.) *Handbook of Human Factors in Litigation*. New York: CRC Press, 38-1 – 38-46.) It is reported, by this same source, to be the most powerful manual gripping method, with a 50<sup>th</sup> percentile grip strength of approximately 500 Newtons, 112 pound force, for males and 270 Newtons, 60 pound force, for females. Thus there are relatively few men who, with such a one-handed grip on a grab bar or stanchion, could exceed its required 250 pound load strength.

See the previously provided table, below, for some examples of various extents of available or utilized points of control in several contexts. Those achieved with the implementation of the proposed new requirements for use of toilets, bathtubs and shower exist, *at a minimum*, in the 3 central red box—with *two points of control*—of the table of options.

Number of Points of Control Via Hands or Feet	≤1	1	2	3	3-4
Standard walker for older adult with altered gait.					✓
Occupational settings with risk of worker falls from heights. Also, stairs where users can use two handrails simultaneously, one on each side.				✓	
<u>Stairs where users have only a single handrail.</u> <i>Grab bar(s) usable for bathtub/shower entry/egress.</i>			✓ ★		
Bathubs/showers with slip resistant underfoot surfaces when wet.		✓			
Bathubs/showers without slip resistant underfoot surfaces when wet, the common condition currently.	✓				

Where underfoot conditions, or capabilities of lower limbs do not provide a reliable point of control, the required two minimum points of control would be a secure handhold for both of ones arms. In some situations a single stanchion could provide two points of control, for example with a bathtub rim-mounted, vertical stanchion which both arms can effectively lock onto, with effective power grips of the hands; this permits pivoting during a sidestep over the rim and onto, or from, a relatively dangerous smooth, wet, curved bottom of a bathtub. Such an approach, which could be from any direction, cannot be achieved with a standard grab bar that is very close to a large wall surface.

For a more detailed discussion of points of control, see the video (one of about 30) available for free streaming at my Website, <http://www.bldguse.com/VideoPage.html>, specifically <https://vimeo.com/channels/866600/117572176> which addresses “points of control” with participation from a few members of the A117 Committee in a 2014 meeting at my Toronto office. Some of the discussion dealt with a related term, “point of contact.”

Stanchions are, like grab bars and handrails, examples of points of control for which the following definition was developed by the Proposal 6-13 Work Group, with discussion of— *and later addition of the second (last) sentence which differentiates stanchions from grab bars.*

**Stanchion** (as defined in the Public Comment Modification Form). A vertical, horizontal or otherwise configured bar that provides for a power grip by one or both hands, to facilitate user ambulation and postural transitions involving sitting, standing, walking, plus stepping over obstacles and on wet underfoot surfaces. Unlike grab bars, stanchions are generally fixed between surfaces or other bars.

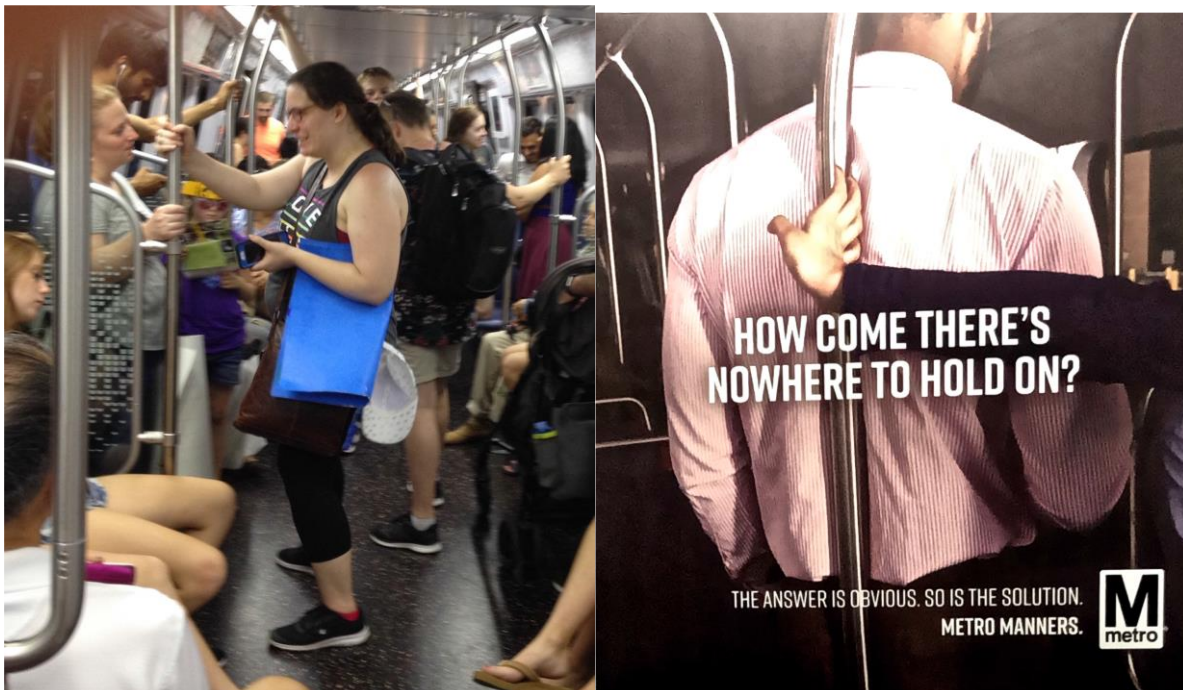
Photographs below represent about two centuries of development of stanchions in the field of transportation vehicle design and their use by ordinary people without formal background in ergonomics, standards development, etc. They also illustrate how stanchions can be attached to other bars as well as being positioned between floor and ceiling (bars or other surfaces).

While on the topic of transportation vehicles, pertinent ADA Guidelines refer to stanchions, e.g., *1192—Americans With Disabilities Act (ADA) Accessibility Guidelines For Transportation Vehicles* refers repeatedly to “Interior circulation, handrails and stanchions.”



The photos below depict the importance of such stanchions to riders as well as to transportation authorities, in this case in the Washington, DC region Metro system. They provided the poster, at the right, depicting one use of stanchions that is rarely seen, but represents an example of “point of contact” which prevents stanchion use as a “point of control” Also note, at the left, the height at which most standing users of the transportation system hold onto stanchions, namely at shoulder to head height, a height that all ages appear to favor—including toddlers’ early use of handholds (discussed in the book chapter I authored, by invitation, years ago [Pauls, J., 2007]. “Stairways for Children.” In *Ergonomics for Children: Designing products and places for toddlers to teens*, Lueder, R and Rice, V. [Eds.], CRC Press, Taylor and Francis, Boca Raton, FL, pp. 543-571.)

Note also the ubiquity of the provision of stanchions; one is generally within reach of every seated or standing passenger in the latest generation of Metro Subway cars (as well as buses).





**Stanchions and Toilets.** For toilet use-related (stand-to-sit and sit-to-stand) transfers, both ergonomics and scientifically-established personal preferences are for points of control for each of our two arms/hands to be available. (See the 2015 paper, *Toilet Grab-Bar Preference and Center of Pressure Deviation During Toilet Transfers in Healthy Seniors, Seniors With Hip Replacements, and Seniors Having Suffered a Stroke*, by Kennedy, Arcelus, Guitard, Goubran, and Sveistrup. Web link: <http://dx.doi.org/10.1080/10400435.2014.976799>.)

The leading preference, identified in this study, was for two handholds on vertical points of control—e.g., stanchions or grab bars—one on each side, and at the front of the toilet; second preference was for only one such point of control (out of five options including also horizontal, “swing-away” and diagonal options.) This is why the revised proposal has the following requirements applying generally (in the case of the first item) and to toilets (in the second item quoted here). Note that the height range specified for vertical stanchions and grab bars, 36 to 60 inches, includes over 95 percent of the US adult population’s range of stature or shoulder height as well as including—at the 36-inch minimum, stature of children in the 3.5 to 4.5-year age range.

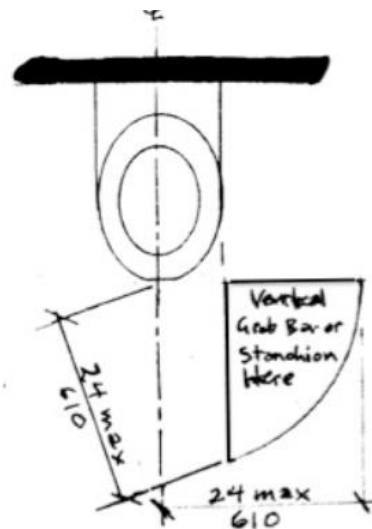
**“612.2.2. Vertical grab bars and stanchions shall be installed so as to be graspable at a height of 36 inches (915 mm) minimum and 60 inches (1525 mm) maximum above the floor.**

Note that, in addition to taking care to utilize good sources of anthropometric data for heights of required vertical points of control, the proponent of Proposal 06-13 also provided a first draft of a plan view figure to help clarify the position of vertical grab bars or stanchions serving toilets. Here follows the proposed text as well as the first-draft sketch

**612.3 Water closets grab bars or stanchions.** The vertical stanchion or grab bar shall be located within an area that is both to the side of the bowl and in front of the bowl within an arc measured 24” from the front and center of the bowl.”

**FIGURE 612.2  
AMBULATORY ACCESSIBLE WATER  
CLOSET IN RELATION TO VERTICAL  
GRAB BAR OR STANCHION LOCATION**

The Figure shows the grab bar or stanchion at the user’s left side but it could be on either side or both sides. Note 24 inches is the radius of the curved portion of the boundary within which stanchion or grab bar centerline is located.



The whole point of the major changes submitted for the A117.1 standard, especially in Section 612 of the plumbing chapter is to add one or two upper body points of control to the single weight-bearing foot, for example, (1) in entry to, using, and exiting from a bathtub or shower enclosure and (2) sitting down on or arising from a water closet. An increasing proportion of the population is in need of such aids if ambulatory people are to remain independently capable, as long as possible, of common activities of daily living without avoidable risks of injury-created disabilities, either temporary or permanent. As well as being a reasonable advance in public health in terms of injury prevention, it is a major quality of life benefit, the value of which greatly exceeds the cost of installing the stanchions and grab bars.

Moreover, as was pointed out in the first dozen or so slides of a very large slide set presentation provided to Committee members of A117 as well as other codes/standards bodies, people reduce their use of relatively dangerous facilities such as stairs, bathtubs, and even showers at an age well below normal retirement age because of the sad state of not just the safety risks but the lack of reasonable *usability* of the facilities. They can do this with stairs, bathtubs and showers, but they cannot do so with toilets. The results of this situation are clear in the statistics on the relatively rapid growth of toilet related injuries but not so with the stairs, bathtubs and showers. See the analyses provided with the original proposal for quantitative data on the extent of this disproportionate growth.

The information below sums up the situation as it can be understood from the injury data in the NEISS system of emergency department treatments augmented by colleagues of the Proponent (at the Pacific Institute for Research and Evaluation (PIRE), in Calverton, Maryland) who provided their expert estimates of how many more treatments were delivered, not in hospitals, but doctors' offices and clinics. The information below comes from the proponent's 144-slide, PowerPoint presentation for the A117 Committee Proposal 06-13-2021 Work Group meeting held 14 March 2022 with slight modifications in August 2022.

As only two slides (numbers 17 and 27 of 144 are extracted here, much is lost of the development of the proponent's realization that bathtubs, showers and toilets pose not only serious injury dangers to all ages but they also pose significant disincentives to use of these facilities as they do with (especially home) stair use also. This shows up in a reduced or only slightly increased relative population-corrected risk of professionally treated injuries for all users of stairs and bathtubs. However, for toilets, whose use cannot be reduced by any age group, the relative population corrected risk increases by a factor of 4.8 for older (age 60+) people relative to 1.00 for middle age (20-59) people. For bathtubs the older (age 60+) people have a population corrected risk of 1.27 relative to 1.0 for middle age (20-59)

people.

		PIRE-calculated annual injuries in USA (2010-14) by treatment type and age					Analysis of Treated Injury Risk of Facility Use — 90% in Homes	
		Hospital-admitted			Total		% (by age)	
		Doc/Outp	ED	via ED	Direct	Total		
<b>S</b> Stairs	00-09	149,399.0	132,344.0	4,313.0	1,515.0	287,561.0	15	(00-19)
	10-19	240,112.0	122,449.0	2,285.5	824.6	365,670.5	66	(20-59)
	20-29	422,114.0	198,838.0	4,634.7	1,533.7	627,120.4	20	(60+)
	30-39	560,978.0	184,438.0	5,628.9	1,930.3	752,955.2		
	40-49	634,787.0	173,156.0	9,241.0	3,050.3	820,234.3		
	50-59	502,896.0	148,100.0	14,903.3	5,131.4	671,030.7		
	60-69	286,908.0	94,429.1	16,586.9	5,644.9	403,568.9		
	70-79	173,515.0	66,376.8	17,891.0	6,021.7	263,804.5		
	≥80	106,488.0	55,507.0	23,272.4	6,356.7	191,624.1		
	Total	1,077,207.0	1,175,439.0	98,754.8	31,991.4	4,383,392.1		
<b>B</b> Bathtubs Showers	00-09	37,421.8	43,503.5	1,167.9	620.3	82,713.5	14	(00-19)
	10-19	35,732.0	23,165.9	449.5	164.8	59,512.1	59	(20-59)
	20-29	70,160.9	36,019.2	1,196.7	438.5	107,815.2	27	(60+)
	30-39	111,471.0	36,842.1	1,355.1	394.4	150,062.6		
	40-49	128,771.0	37,902.7	2,180.3	666.2	169,520.2		
	50-59	123,201.0	38,110.5	3,513.7	1,235.5	166,060.7		
	60-69	70,778.2	24,719.1	4,742.3	1,571.3	101,811.0		
	70-79	50,653.0	18,959.1	5,648.5	1,762.5	77,023.1		
	≥80	50,961.4	23,964.3	9,880.1	2,699.0	87,504.8		
	Total	679,150.0	283,187.0	30,134.0	9,552.5	1,002,023.5		
		%	68	28	3	1		
<b>T</b> Toilets	00-09	8,189.7	7,788.1	200.2	79.0	16,257.0	7	(00-19)
	10-19	3,013.0	2,532.5	84.2	24.4	5,654.0	34	(20-59)
	20-29	7,713.5	5,373.5	250.0	125.0	13,461.9	58	(60+)
	30-39	15,319.0	5,987.9	459.1	125.2	21,891.2		
	40-49	19,713.9	6,995.6	1,055.7	391.1	28,156.3		
	50-59	26,914.0	9,408.3	2,112.3	673.5	39,108.2		
	60-69	30,101.1	10,529.7	3,840.1	1,318.7	45,789.6		
	70-79	28,111.9	10,741.6	5,512.9	1,751.8	46,118.2		
	≥80	44,531.3	21,436.1	12,449.2	3,353.6	81,770.2		
	Total	181,607.0	80,793.3	25,963.8	7,842.2	298,206.3		
		%	62	27	9	3		

		Analysis of Treated Injury Risk of Facility Use — 90% in Homes				
		% (by age)	Rate/1000*	Relative Risk	Use?	Facility
<b>S</b> Stairs	15 (00-19)	15	7.93	0.46	Yes	
	66 (20-59)	66	17.2	Ref. 1.00	Yes	Stairs
	20 (60+)	20	14.6	0.85	Can Limit and Do	
<b>B</b> Bathtubs Showers	14 (00-19)	14	1.73	0.49	Yes	
	59 (20-59)	59	3.55	Ref. 1.00	Yes	Bathtub Shower
	27 (60+)	27	4.51	1.27	Can Limit and Do	
<b>T</b> Toilets	7 (00-19)	7	0.27	0.43	Yes	
	34 (20-59)	34	0.61	Ref. 1.00	Yes	Toilet
	58 (60+)	58	2.94	4.82	Cannot Limit It is a major health issue.	

\*US-2012

The photographic series, below with a century-old trolley, provides a brief story of how effective stanchions are, even for young children encountering steps comparable in height to what is needed to surmount the wall of a typical bathtub; the height depicted here is about 16 inches (400 mm), comparable to what is found in minimum standard (e.g., *International Residential Code*) permitted stairways for dwelling units—except there is no intermediate step to

use as many older people need to do when using stairs (with both feet using every step). Note also the relatively puny grab bar to the woman's left; it lacks the usefulness of the two (platform to ceiling) stanchions, marked in yellow, better serving the formidable two-riser stair in terms of both length and location.



An important lesson, from the photo sequence above, is that stanchions provide more options for placement and more options for users to choose the points of control they perceive as important to their task and safety. In other words ordinary people, even of young age, are displaying skill in ergonomics (the science and technology of how people utilize things, systems, etc. available to them to perform tasks effectively, comfortably, and safely).

For purposes of this A117.1 proposal, along with grab bars, it should be clear that stanchions are reliable, indeed superior, time-tested means of providing for “points of control” and they provide options for location and length that greatly exceed what conventional grab bars can provide—as they do not rely on walls from which they cantilever. (They can be *between* walls, *between floor and ceiling*, etc.)

#### **Section 612.4. Bathtub Grab Bars or Stanchions**

The graphic on the next page combines all of the stanchion and conventional grab bar options set out in the partial re-write of A117.1 Chapter 6, “Plumbing Elements and Facilities,” specifically for bathtubs.

All of the eight options are illustrated in the graphic below. The options are in two groups, three options for the one stanchion or grab bar on the non-access side or back wall and five options for the one required grab bar or stanchion on the access side (front). At the front, the vertical stanchion has options for placement anywhere along the length of the bathtub (depending on fixture layout in the bathroom and where the clear, half bathtub length area (required by **Section 612.4.1 Access side of bathtub**) is located—here in front of the water closet (WC).



On the next page the stanchion is shown mid-tub length (where it is *surface---mounted* (with Automotive Grade RTV adhesive) on the *steel* tub rim, but could also be floor mounted for other tubs with less strength or rigidity) so it also serves the WC per proposed new section quoted above.

**612.4.1 Access side of bathtubs.** A clearance shall be provided adjacent to the bathtub extending 30 inches minimum in length and 30 inches minimum in depth. A vertical grab bar or stanchion shall be provided on the access side of the bathtub, adjacent to the clearance and complying with Section 612.4.1.1, 612.4.1.2 or 612.4.1.3.

**612.4.1.1 Vertical stanchion.** A vertical stanchion shall be installed on the rim or the bathtub or on the outside of the bathtub within 4 inches measure horizontally from the centerline of the stanchion to the outside face of the bathtub at the stanchion.

**612.4.1.2 End wall grab bar interior of bathtub.** A vertical grab bar shall be installed on an end wall 9 inches minimum and 12 inches maximum measured horizontally from the centerline of the grab bar to the outside face of the bathtub below the grab bar.

**612.4.1.3 End wall grab bar exterior of bathtub.** A vertical grab bar shall be installed on an end wall 4 inches maximum measured horizontally from the centerline of the grab bar to the outside face of the bathtub below the grab bar.



Note the options for the access side, end wall-mounted grab bar do not permit placing this grab bar where it would interfere with the installed shower curtain rod (or track) or installation of an enclosure system of sliding glass panels for example. Several inches of horizontal dimension are reserved on the end walls for such water control barriers, e.g., a shower curtain, to seal to the end walls.

The most common defect with grab bar placement the author saw repeatedly in his many stays in hotels around the world was having both the shower curtain and the vertical grab bar competing for the same region of the end wall. The result: during a shower, water ended up leaking to the bathroom floor, in some cases getting into end walls with moldy results.

Here follow the proposed texts for the bathtub grab bars or stanchions with the graphic on the prior and next page illustrating the full range of options. *However, note that the illustration of the diagonal grab bars has incorrect lower end heights above the bathtub rim (based on another, early design) which must be corrected here to a 3 to 6-inch range above the tub rim.*

*Again, disregard the dimension of 8" min to 10" max above the bathtub rim for the bottom of 10 the diagonal grab bar examples; the distance in the current A117 proposal is 3 to 6 inches above the bathtub rim. The illustration was from an earlier draft proposal.*



**612.4.2 Non-access Side of Bathtubs.** A grab bar or stanchion shall be provided on the nonaccess side of the tub complying with Section 612.4.2.1, 612.4.2.2 or 612.4.2.3.

**612.4.2.1. Horizontal Grab Bar.** A horizontal grab bar shall be installed on the back wall and shall be of 36" minimum in length with the ends located 12 inches maximum from the from the head and control ends of the bathtub.

**612.4.2.2 Horizontal Stanchion.** A horizontal stanchion shall be installed between the head and control end walls.

**612.4.2.3 Diagonal Grab Bar.** The diagonal grab bar shall be installed on the back wall and shall be 36 inches minimum in length. Its slope shall be 30 degrees minimum to 60 degrees maximum to horizontal. The upper end shall extend to 12 inches (305 mm) maximum from

the control end wall. The lower end of the diagonal grab bar shall be 3 inches minimum and 6 inches maximum above the bathtub rim.

**612.5. Shower Compartment Grab Bars and Stanchions.** For shower compartments having a diagonal dimension of 51 inches (1295 mm) maximum, a grab bar or stanchion shall be provided in accordance with Section 612.5.1, 612.5.2 or 612.5.3. For shower compartments having a diagonal dimension of greater than 51 inches (1295 mm), two grab bars or stanchions shall be provided with one in accordance with Section 612.5.1, 612.5.2 or 612.5.3 and a second grab bar or stanchion in accordance with Section 612.5.4 or 612.5.5.

**612.5.1 Horizontal Grab Bar Option.** A horizontal grab bar shall be installed with a minimum length of 24 inches (610 mm) and located inside the compartment with one end within 4 inches (100 mm) of the shower entrance opening.

**612.5.2 Vertical Grab Bar Option.** A vertical grab bar shall be installed with the grab bar centerline located within 3 inches (75 mm) of the shower entrance opening, either inside or outside the compartment.

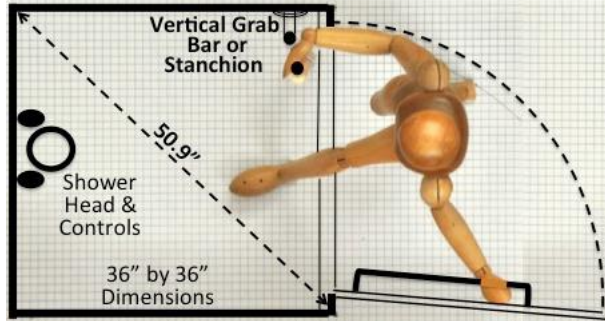
**612.5.3 Vertical Stanchion.** A vertical stanchion shall be installed with the stanchion centerline located within 3 inches (75 mm) of the shower entrance opening, either inside or outside the compartment.

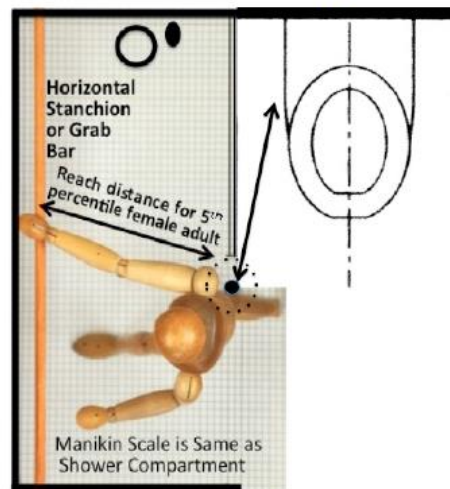
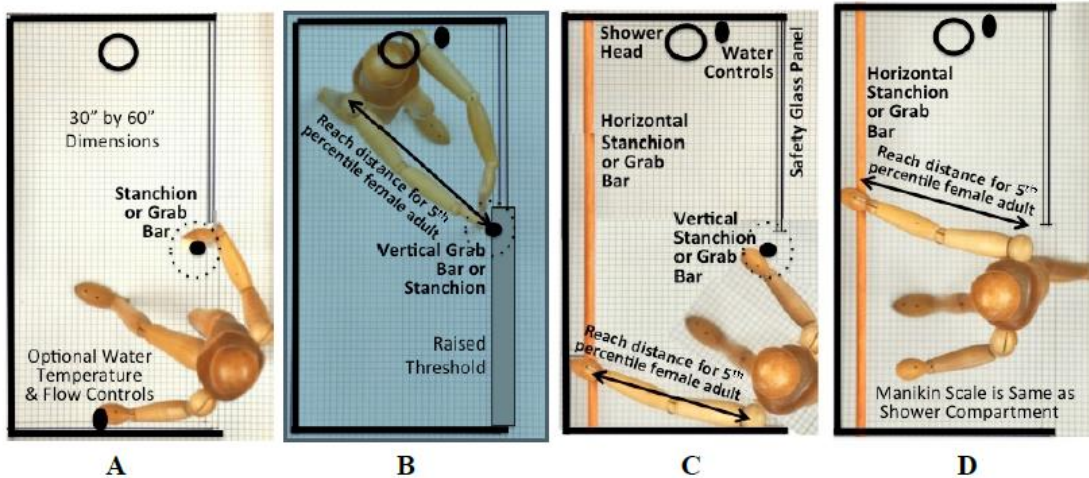
**612.5.4. Second grab bar.** A horizontal grab bar shall be provided on the back wall of the shower. The grab bar shall have its ends extending to within 12 inches of each end of the side walls.

**612.5.5. Second stanchion** A horizontal stanchion shall be provided on the back wall of the shower. The stanchion shall extend the full length of the back wall mounted between side walls.

To help understanding of these conditions and grab bar plus stanchion options, the proponent initiated a different form of illustration of options for two increasingly standard shower compartment plans differing by the maximum horizontal, diagonal dimension being no greater than 59 inches or being greater than 59 inches. The latter include showers replacing, in approximately the same space a fairly standard, roughly 30-inches by 60-inches bathtub area.

The different form of illustration of options involved use of ¼-size plans and ¼-size artists manikins photographed, with a (faint) 1-inch grid, from an overhead position, using a mirror to get a longer shot and better perspective (as the manikins were about 16 inches high). Here are the options explored starting with plan view of 36-inch by 36-inch (915 mm by 915 mm) in plan size, addressed in 612.5.2 and 612.5. (612.5.1, with the horizontal GB or stanchion option is not shown for this smaller size of shower, although it is a permitted option).





Option C Augmented to show vertical stanchion also serving adjacent WC. See accompanying illustration below.

**Options for Using Vertical Stanchions or Grab Bars At Shower Entrance With And Without Full Length Horizontal Stanchion or Grab Bar Per 612.5.4.**



Pending discussion with the A117 Committee and its Chair on suitability of invoking an option to restrict larger showers to Option C based on an individual case assessment of adequate slip



resistance underfoot in the shower, only a two grab bar or stanchion combination should be accepted for the larger showers. This is due to much greater consequences of slipping in the larger plan showers. Committee views on this matter are requested before or during the December 15<sup>th</sup> meeting. A simple pass/fail test of onsite, wet, shower pan slip resistance, performable *without* a tribometer (or other specialized equipment) and skilled operator, will be presented to the entire committee.

**Appendix of Some Expanded Consideration of Certain Topics that are prominent in this Proposal: Consumer acceptance of stanchions and the proposal (within 06-13) on changing the 1.5 inch clearance between a grab bar (or stanchion) surface to a minimum requirement.**

**Stanchion Acceptance.** A significant aspect of the proposal for A117.1 is the introduction of stanchions, the history and ubiquity—*outside of bathrooms*—has already been addressed above. In the photos below, they are seen in three of the contexts at the heart of A117.1 Chapter 6, as it will be amended with the acceptance of this proposal which deals, typically with new construction.

All of the examples below represent retrofit installations. Moreover, they are all retrofits in rental contexts where damage to walls is frowned upon by owners. Thus all of the examples shown of stanchions in this proposal narrative, include stanchions that can be removed (followed with the usual repainting between tenancies) without any screw holes in floors, ceilings and, most important (usually) walls.

Modern RTV (Room Temperature Vulcanizing) adhesives hold these stanchions in place with holding capability easily meeting the 250-pound strength requirement. This adds new usefulness to A117.1 and, more importantly, to many people who develop disabilities of all types as they age and who want to “age in place” where they feel most at home.

Stanchions also avoid any grab bar stigma issues as, evident especially in the two photos at the center and right sides below, the stanchions appear totally integrated with the décor, even serving as a much needed lighting pole to enhance bathroom lighting while saving energy. These stanchions all comply with the proposed requirements, completely for the contexts illustrated, from left to right: bathtub access side vertical stanchion (with a no-cost bonus of also serving as the newly required vertical stanchion for the WC).

At the center is another stanchion, this one color coordinated with its surrounds and the structural supports—to the vanity—color coordinated with it (while giving extra structural support to the stanchion). At the right, the satin stainless steel stanchion matches the décor of the shower enclosure and is discretely tucked into a recess while being accessible for both entering and exiting, stepping over the 4-inch sill below the shower door. Both of the stanchions at the center and right occupy the same bathroom and both contend with the 8-foot ceiling there (which has been tested to the 250-pound criterion—without any plastic deformation)



The photo at the left side demonstrates two options for a center tub-length stanchion, one affixed with RTV adhesive to a 60-year old enamel steel bathtub that has no problem with a test 330-pound, lateral load held for three hours. For newer, less rigid bathtub materials such as acrylic or fiberglass, manufacturers have raised a huge fuss over rim mounting of stanchions. They are easily appeased with the option of mounting on the adjacent floor—which is far more sturdy than the newer tubs are and has no issues with the RTV adhesive. Again, with many solid, well performing steel bathtubs currently installed, there is much scope for both the rim- and floor mounting options for securing stanchions in both new and existing bathrooms.

There was also some opposition—*quickly addressed*—from those concerned with the stanchion being in the way of some people with disabilities not being able to swing their fully extended legs over the tub rim when seated on a bathtub seat. Note that in the photo above, left side, there is barely room for such legs at the closely positioned WC which effectively blocks almost half the length of the tub. Notably the proposed language for A117 allows the vertical, access-side stanchion to be placed anywhere on or immediately adjacent to the entire length of the bathtub. Thus the stanchion can be placed where it suits a bather who desires to use a bathtub seat, etc. (BTW, the bathroom is totally inaccessible to a standard wheelchair and the 60-year old apartment building is not very accessible as well as being difficult to evacuate for those unable to use stairs.)



This augmented photo illustrates the possible dilemma over such vertical stanchion placement. Is it too close to the seat; is it too far from the seat (like the water controls are), or is it just right? The proposal is open to all options on this matter (keeping in mind the value of the stanchion also serving the water closet as set out in proposed new Section 604.12 in which the performance requirement of a 28-inch reach distance is utilized.) The 28 inches is based on a reachability analysis as well as being explained and illustrated in Appendix A to this proposal; a very large (200-plus) slide presentation. Note there is also a second vertical stanchion digitally added at the vanity side serving the water closet.

Finally—*almost*— at least for this supplementary “REASON” section of the proposal, a critical detail that, I hope will be accepted to no longer specify a fixed 1.5- inch clearance between a grab bar and the wall to which it is attached. Here follows the proposed change and below that is the experiment that was painfully executed in the course of addressing this matter empirically. The clearance in the photo sequence that follows was exactly 1.5 inches yet an older male adult’s hand could pass through, sustaining bruising to the back of the hand. Surely this issue of adding one word, “minimum” will be accepted as a similar change has been accepted on related topics. Moreover (recognizing Figures do not govern over requirements in text), A117-2017 has a Figure (609.3 on page 88) showing the 1.5-inch spacing as a minimum for a horizontal grab bar.

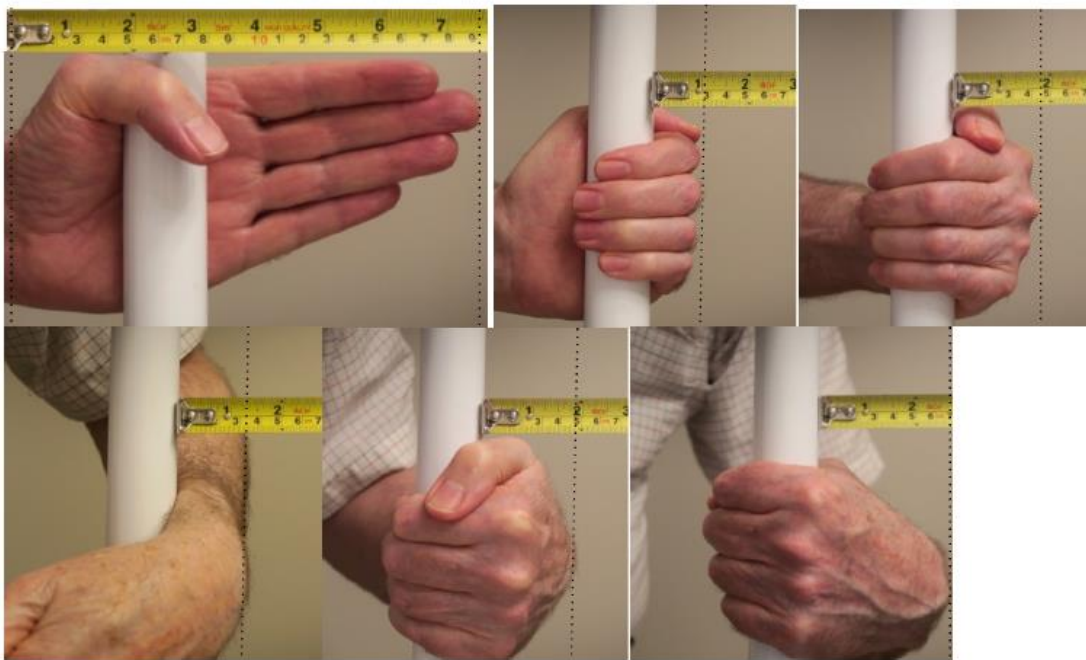
**609.3 Spacing.** The space between the wall and the grab bar or stanchion shall be 1 1/2 inches (38 mm) minimum. The space between the grab bar or stanchion and projecting objects below and at the ends of the grab bar or stanchion shall be 1 1/2 inches (38 mm) minimum. The space between the grab bar or stanchion and projecting objects above the grab bar or stanchion shall be 12 inches (305 mm) minimum.





Finally, for more insights into the 1.5-inch clearance in 609.3, there is not just the risk of difficult- to-heal internal hand injuries with the current absolute 1.5-inch spacing, but also bruising and abrasions to ones knuckles. See the photos below.

Here follows a sequence of photographs taken of the proponent’s hand size (of 7 1/2- inch, 190 mm length) and grasping a 1.3-inch (33 mm) diameter stanchion complete with a scale showing how much of the hand projects into the space that would be available with a wall surface nearby.



Clearly for hand sizes such as for an 80-year old US male (depicted here), the absolute spacing of 1.5 inches (38 mm), currently in the ANSI A117.1 standard needs to be reassessed if knuckle damage is to be prevented along with injuries to the thickest part—and very complex part—of the hand, at the base of the thumb. *For these areas of a large adult male hand, 1 3/4 inches (45 mm) would be an improved minimum and 2 inches would be even more prudent.* The most preferred option would consist of revising the (minimum) clearance, throughout 609.3 and 609.5 to 2 inches (51 mm) in which case it could be left as an

absolute clearance—*if that was still desired for some reason*—for horizontal grab bars as well as the stipulated minimum clearance everywhere else.]

Thank you all.

Jake Pauls, BArch, CPE, HonDSc, PROPONENT OF PROPOSAL 06-13-2021

Web: [www.bldguse.com](http://www.bldguse.com)

Mobile: 301-706-8830

**Committee Action:** Tabled

**Notes 8-9-2022 and 8-25-2022:** Motion is AS

**Question divided:**

604 – AS 5-22-2/D 24-6-2

607 – AS 7-18-4/Motion to Disapprove;

Motion to table 17-9-2 till 8/25/2022 call

Motion to untable passed.

Motion to table part 2 to end of chapter 6 carries with 3 votes in opposition.

608 –

Modification to 608.9.1 and 608.9.3 passed 19-1-3

Motion to table parts 3 to end of chapter 6 carries with 1 vote in opposition

609 – Motion to table parts 4 to end of chapter 6 carries with 1 vote in opposition

**Modification (if any):**

**Divided question Item 3: *Modification passed 19-1-3***

**Further modify as follows:**

**608.9.1 At shower exterior.** A vertical grab bar or stanchion shall be provided outside of the shower compartment, adjacent to the access opening within ~~28 inches (710 mm)~~ 24 inches (610 mm) of the center of the shower entrance opening width. The grab bar or stanchion shall extend from 24 inches (610 mm) maximum to 60 inches (1524 mm) minimum, measured vertically above the finished floor.

**608.9.3 For larger shower interior.** For showers with any interior plan dimensions exceeding 51 inches (1295 mm), including diagonally between corners, a grab bar or stanchion located interior to the shower compartment shall be ~~28 inches (710 mm)~~ 24 inches (610 mm) maximum, measured horizontally to the access to the shower. If oriented vertically, the grab bar or stanchion shall extend from 24 inches (610 mm) maximum to 60 inches (1524 mm) minimum, measured vertically above the finished floor outside the shower. If oriented horizontally, the grab bar or stanchion shall have a length 36 inches (915mm) minimum at a height, measured vertically above the finished floor outside the shower, of 48 inches (1220 mm) minimum and 60 inches (1524 mm) maximum.

**Notes 8-25-2022:**

**Reason for modification:** The modification is based on anthropometric data for reach. The 28” is arm length, and the 24” would be to the center of the hand. This is a bar that is intended to be graspable and needs to be closer for stability reasons.

**Notes 12-15-2022:**

This proposal was split and tabled during the 8-25-2022 meeting. The proponent submitted a replacement proposal that was substantially different from the original proposal. Therefore, the actions taken on 8-25-2022 are void and the discussion will start over.

- 06-13-2021 Replacement: AM based on replacement modification; divided question
  - Discussion begun on 12-15-2022
  - Part 1 - Definition for ‘stanchion’ – AM 5-21-2; D 23-3-3
  - Part 2 - Section 603 and 604; The chair ruled that the revision of Section 604.10 to 612 is out of order. This change is not included. AM 11-13-1; D 25-4-2

**SECTION 604  
WATER CLOSETS AND TOILET COMPARTMENTS**

**604.1 General.** Wheelchair accessible water closets and toilet compartments shall comply with Section 604. Compartments containing more than one plumbing fixture shall comply with Section 603. Wheelchair accessible compartments shall comply with Section 604.9. Ambulatory accessible compartments shall comply with Section ~~604.10-612~~.

**Exception:** Water closets and toilet compartments primarily for children’s use shall be permitted to comply with Section 604.11 as applicable.

- Part 3 – Section 609 –
  - The chair ruled that 609.2.2 change from 4.8 to 6.3 for grab bars is out of order and is therefore only applicable to stanchions.

**609.2.2 Noncircular cross section.** Grab bars and stanchions with a noncircular cross section shall have a cross section dimension of 2 inches (51 mm) maximum, and a perimeter dimension of 4 inches (100 mm) minimum and ~~4.8~~ 6.3 inches (160 mm) maximum. Corner radius shall be 1/4 inch (6 mm) minimum.

- Part 4 – Motion to hear Section 609.9 separated out from 609
- The item was tabled due to the discussion extending 45 minutes past the scheduled meeting time. Tabled 12-9-0

**Notes 1-5-2023:**

- Removed from table at start of 1/5/2023 meeting - unanimous
- Part 3 – 609.1 through 609.8
  - Jake requested to remove from Section 609.2.2 change from 4.8 to 6.3. The chair ruled that this will be included as part of proposed modification.
  - Question was called at 1:28 p.m. – 6 against, motion passes

- Part 3 – Section 609.1 through 609.8 - AM 4-26-3; D 24-6-2
- Part 4 – Section 609.9
  - Modification – strike ‘and sealed’ 24-0-1
  - Modification – see report for complete mod 22-2-3
  - Part 4 AM with 2 modifications - 26-1-4
- Part 5 – Section 612 –
  - Divided to consider conceptual vote of 612 and 612.1 (1<sup>st</sup> of 2 sections with this number) separately – AM 14-14-2; The chair votes in support to break tie
  - Discussed remainder by parts, 612.2, 612.3, 612.4 – no votes taken
  - Discussion will start again at the 1/19/2023 call with Section 612.5

**Notes 1-19-2023:**

- Removed from table at start of 1/19/2023 meeting
- Part 6 –
  - Discussion of Section 612.5
  - Two documents from Larry Schneider were sent out with the email for the general meeting reminder on Tuesday, Jan. 17.
    - Stanchions for A117.1\_LMS
    - Conflict between Grab bars NFPA vs Accessibility Model\_LMS
  - Section 612.1 (2<sup>nd</sup> of 2 sections with this number) through 612.5.5 – AM 1-21-2; D 25-1-2

**Committee Action:** The committee voted on the replacement proposal, so the standing motion was AM

- Part 1 - Definition for ‘stanchion’ – AM 5-21-2; D 23-3-3
- Part 2 - Section 603 and 604 - AM 11-13-1; D 25-4-2
- Part 3 – Section 609.1 through 609.8 - AM 4-26-3; D 24-6-2
- Part 4 – Section 609.9 - AM with 2 modifications - 26-1-4
- Part 5 – Section 612 and 612.1 (Scope) –AM 15-14-2
- Section 612.1 (General) through 612.5.5 – AM 1-21-2; D 25-1-2

**REPORT OF HEARING:**

**Modification (if any):**

Part 4 - Further modify as follows:

**609.9 Durability in presence of water.** Grab bars and stanchions, including mountings, shall be installed ~~and sealed; to protect structural elements from~~ or provided with permanent drainage for components subject to water intrusion and moisture.

**Committee Reason:**

**Part 1** – definition of stanchion

The new definition was disapproved for the following reasons. The description is more about the purpose of the stanchion rather than a definition of what a stanchion is. The proposed language

does not clearly define a difference between a grab bar and a stanchion – this could be read to apply to both.

**Part 2 - Section 603 and 604**

The chair ruled that the revision of the reference in Section 604.1 from Section 604.10 to 612 is out of order. This change is not included.

Part 2 was disapproved for the following reasons. The proposal to add ‘wheelchair accessible’ is incomplete – it revised only two sections. This is not an editorial change as indicated in notes in the proposal. This revision does not add clarity to the confusion between the new requirements proposed for ‘ambulatory accessible bathrooms’ and the current ‘ambulatory accessible compartments.’

**Part 3 – Section 609.1 through 609.8**

The chair ruled that 609.2.2 change from 4.8 to 6.3 for grab bars is out of order and is therefore only applicable to stanchions.

Jake requested to remove from Section 609.2.2 the change from 4.8 to 6.3. The chair ruled that this will be included as part of proposed modification.

Part 3 was disapproved for the following reasons. In Section 609.2.2, the ¼” edge for a grab bar or stanchion is greater than the 0.01” edge for handrails currently in the IBC that is based on studies provided by the Stairway Manufacturer’s Association. There was no justification provided for the significant difference. In Section 609.3, the ½” minimum gap proposed for behind the grab bar would be a conflict with the ADA. There is also a safety concern for persons that rest their forearm on top of the grab bar if the gap was larger. In Section 609.5 the ¼” edge for surfaces would be confusing for wall surfaces such as tile. The justification provided for grasping of a bar does not translate to edges on surfaces behind a grab bar or stanchion. In Section 609.7, it is not clear what the exception is attempting to exempt you from in the main text.

**Part 4 – Section 609.9**

The intent of the modification was to provide performance language instead of prescriptive language to protect connections from failing. The second modification to remove “and sealed” was to coordinate with that intent, since ‘and sealed’ could be read to not allow drainage holes. There were concerns that adding “structural elements” could be read to apply only to the walls or floors and not the screws in the connections. Common failure is a mis-match of metal types between the screws and the grab bars, or the rusting of the screws holding the grab bars in place. If the proposal to add stanchions is disapproved, the removal of “and stanchions” would be referred to the editorial committee. The committee agreed with the original intent of the proposal – to reduce failure of the grab bar connections over time.

**Part 5 – Section 612 and 612.1 (Scope)**

Section 612.1 was acted on separately in order to determine the committee's desired direction on the remainder of the section. If disapproved, the proponent indicated the intent to move for disapproval of the remainder. The vote on the motion to approve 612 and 612.1 Scope was tied with the chair voting in favor of the motion to allow for complete discussion of the topic.

**Part 6 – 612.1 (General) through 612.5**

The proposal was disapproved.

While this proposal does not include scoping, the committee was reluctant to adopt these requirements without knowing where they would be scoped due to concerns that if this applied to units that are required to meet other accessibility standards, these grab bar locations would conflict with the requirements in other standards.

While specific methods of attachment of vertical stanchions are not specified, there were concerns that the attachment of the vertical stanchion to the edge of the bathtub could cause damage and/or affect the fixture's warranty. Regarding use of adhesives, it is not clear how one would document compliance with loading requirements and suitable adhesive type.

612.3 – There were concerns that the vertical stanchions at water closets would be an obstruction for persons trying to get to the water closet with a walker, cane or crutches. Swing up grab bars should also be considered as a possible option.

612.4 – There were concerns that vertical stanchion at bathtubs that comply with these location requirements could be an obstruction for persons who wanted to transfer to a bathing seat and/or parents trying to bath their children in the tub.

There were concerns that with a vertical stanchion on the edge of a tub, a shower curtain would not adequately contain water and may contribute to a slip and fall hazard on a wet floor.

The diagonal grab bars on the rear wall, if located with the front edge close to the wall, would place the diagonal bar close to the front of the tub. This is not consistent with the intent expressed in the examples in the reason statement.

612.5 – The requirements for the vertical grab bars and stanchions are stated in relation to the shower opening, but do not address fixtures with swinging or sliding doors.

604 et al-PAULS.doc

<b>Report for 06-13– 2021</b>		
<p><b>Committee decision:</b> The committee voted on the replacement proposal, so the standing motion was AM</p> <ul style="list-style-type: none"> <li>Part 1 - Definition for 'stanchion' D 23-3-3</li> <li>Part 2 - Section 603 and 604 - D 25-4-2</li> <li>Part 3 – Section 609.1 through 609.8 - D 24-6-2</li> <li>Part 4 – Section 609.9 - AM with 2 modifications - 26-1-4</li> <li>Part 5 – Section 612 and 612.1 (Scope) –AM 15-14-2</li> <li>Section 612.1 (General) through 612.5.5 –D 25-1-2</li> </ul>	<p><b>Committee Vote at Meeting:</b> See notes in first column</p>	<p><b>Committee Vote on Ballot:</b></p>
<p><b>REPORT OF HEARING:</b> Modification (if any): Part 4 - Further modify as follows:</p>		
<p><b>609.9 Durability in presence of water.</b> Grab bars and stanchions, including mountings, shall be installed and sealed; to protect structural elements from or provided with permanent drainage for components subject to water intrusion and moisture.</p>		
<p>Committee Reason:</p> <p><b>Part 1 – definition of stanchion</b> The new definition was disapproved for the following reasons. The description is more about the purpose of the stanchion rather than a definition of what a stanchion is. The proposed language does not clearly define a difference between a grab bar and a stanchion – this could be read to apply to both.</p> <p><b>Part 2 - Section 603 and 604</b> The chair ruled that the revision of the reference in Section 604.1 from Section 604.10 to 612 is out of order. This change is not included. Part 2 was disapproved for the following reasons. The proposal to add 'wheelchair accessible' is incomplete – it revised only two sections. This is not an editorial change as indicated in notes in the proposal. This revision does not add clarity to the confusion between the new requirements proposed for 'ambulatory accessible bathrooms' and the current 'ambulatory accessible compartments.'</p> <p><b>Part 3 – Section 609.1 through 609.8</b> The chair ruled that 609.2.2 change from 4.8 to 6.3 for grab bars is out of order and is therefore only applicable to stanchions. Jake requested to remove from Section 609.2.2 the change from 4.8 to 6.3. The chair ruled that this will be included as part of proposed</p>		



**Report for 06-13– 2021**

modification.

Part 3 was disapproved for the following reasons. In Section 609.2.2, the ¼" edge for a grab bar or stanchion is greater than the 0.01" edge for handrails currently in the IBC that is based on studies provided by the Stairway Manufacturer's Association. There was no justification provided for the significant difference. In Section 609.3, the ½" minimum gap proposed for behind the grab bar would be a conflict with the ADA. There is also a safety concern for persons that rest their forearm on top of the grab bar if the gap was larger. In Section 609.5 the ¼" edge for surfaces would be confusing for wall surfaces such as tile. The justification provided for grasping of a bar does not translate to edges on surfaces behind a grab bar or stanchion. In Section 609.7, it is not clear what the exception is attempting to exempt you from in the main text.

**Part 4 – Section 609.9**

The intent of the modification was to provide performance language instead of prescriptive language to protect connections from failing. The second modification to remove "and sealed" was to coordinate with that intent, since 'and sealed' could be read to not allow drainage holes. There were concerns that adding "structural elements" could be read to apply only to the walls or floors and not the screws in the connections. Common failure is a mis-match of metal types between the screws and the grab bars, or the rusting of the screws holding the grab bars in place. If the proposal to add stanchions is disapproved, the removal of "and stanchions" would be referred to the editorial committee. The committee agreed with the original intent of the proposal – to reduce failure of the grab bar connections over time.

**Part 5 – Section 612 and 612.1 (Scope)**

Section 612.1 was acted on separately in order to determine the committee's desired direction on the remainder of the section. If disapproved, the proponent indicated the intent to move for disapproval of the remainder. The vote on the motion to approve 612 and 612.1 Scope was tied with the chair voting in favor of the motion to allow for complete discussion of the topic.

**Part 6 – 612.1 (General) through 612.5**

The proposal was disapproved.

While this proposal does not include scoping, the committee was reluctant to adopt these requirements without knowing where they would be scoped due to concerns that if this applied to units that are required to meet other accessibility standards, these grab bar locations would conflict with the requirements in other standards.

While specific methods of attachment of vertical stanchions are not specified, there were concerns that the attachment of the vertical stanchion to the edge of the bathtub could cause damage and/or affect the fixture's warranty. Regarding use of adhesives, it is not clear how one would document compliance with loading requirements and suitable adhesive type.

612.3 – There were concerns that the vertical stanchions at water closets would be an obstruction for persons trying to get to the water closet with a walker, cane or crutches. Swing up grab bars should also be considered as a possible option.

612.4 – There were concerns that vertical stanchion at bathtubs that comply with these location requirements could be an obstruction for persons who wanted to transfer to a bathing seat and/or parents trying to bath their children in the tub.

There were concerns that with a vertical stanchion on the edge of a tub, a shower curtain would not adequately contain water and may contribute to a slip and fall hazard on a wet floor.

The diagonal grab bars on the rear wall, if located with the front edge close to the wall, would place the diagonal bar close to the front of the tub. This is not consistent with the intent expressed in the examples in the reason statement.

612.5 – The requirements for the vertical grab bars and stanchions are stated in relation to the shower opening, but do not address fixtures with swinging or sliding doors.

**PUBLIC COMMENT- FIRST DRAFT:**

Proponent:

Desired Action:

Modification:

Reason:

**Committee decision: AS/AM/D**

**Committee Vote at Meeting:**

**Committee Vote on Ballot:**

**REPORT OF HEARING – FIRST DRAFT**

Modification (if any):

Committee Reason:

**PUBLIC COMMENT- SECOND DRAFT:**

Proponent:

Desired Action:

Modification:

Reason:

**Committee decision: AS/AM/D**

**Committee Vote at Meeting:**

**Committee Vote on Ballot:**

**FINAL ACTION:**

Modification (if any):

Committee Reason:

## 06-14 – 2021

604.3.1, 1103.11.2.4.2, 1104.11.3.1.2.2.1, Figures 604.3, 1103.11.2.4(C), 1104.11.3.1.2(D)

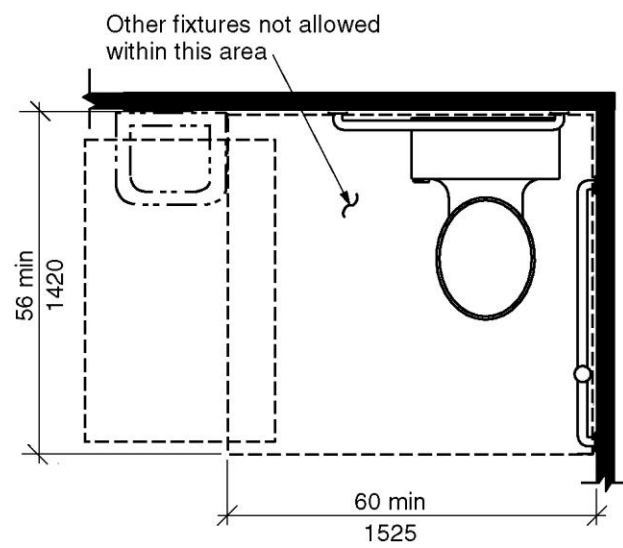
**Proponent:** Edward Steinfeld, IDEA Center, University at Buffalo, representing RESNA

**Revise as follows:**

### SECTION 604 WATER CLOSETS AND TOILET COMPARTMENTS

#### 604.3 Clearance.

**604.3.1 Clearance width.** Clearance around a water closet shall be 60 inches (1525 mm) minimum in width, measured perpendicular from the sidewall. The clearance shall be measured to the face of vanity cabinets, where provided.



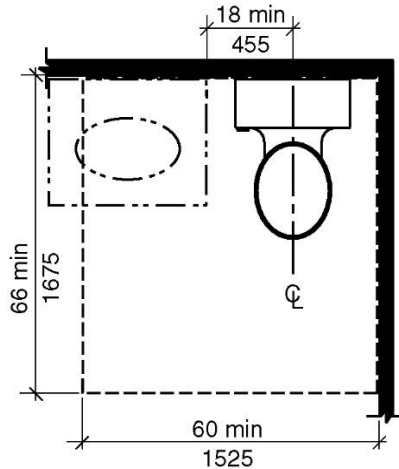
**Note:** Clearances shall be measured to the face of vanity cabinets, where provided.

#### FIGURE 604.3 SIZE OF CLEARANCE FOR WATER CLOSET

### SECTION 1103 TYPE A UNITS

**1103.11.2.4.2 Clearance width.** Clearance around the water closet shall be 60 inches (1525 mm) minimum in width, measured perpendicular from the side wall. The clearance shall be measured to the face of vanity cabinets, where provided.



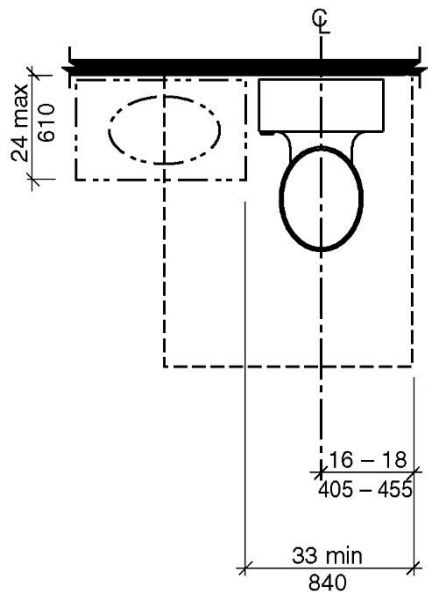


**Note:** Clearances shall be measured to the face of vanity cabinets, where provided.

**FIGURE 1103.11.2.4(C)**  
**WATER CLOSETS IN TYPE A UNITS - CLEARANCE WITH LAVATORY (OVERLAP EXCEPTION)**

**SECTION 1104**  
**TYPE B UNITS**

**1104.11.3.1.2.2.1 Clearance width.** Clearance around the water closet shall be 48 inches (1220 mm) minimum in width, measured perpendicular from the side of the clearance that is 16 inches (405 mm) minimum and 18 inches (455 mm) maximum from the water closet centerline. Clearances shall be measured to the face of vanity cabinets, where provided.



**Note:** Clearances shall be measured to the face of vanity cabinets, where provided.

**FIGURE 1104.11.3.1.2(D)**

**CLEARANCE AT WATER CLOSETS IN TYPE B UNITS CLEARANCE WITH LAVATORY OVERLAP**

**REASON:** The current requirements and figures do not state clearly where the clearances should be measured at vanity cabinets. The lack of specificity leads to confusion in the field when checking compliance and citations for inconsequential differences, e.g. ¼ or ½ in. overhangs of countertops. Slight overhangs, which is a common practice makes no difference in accessibility.

**Committee Action:** 23-2-0 Disapproved

**REPORT OF HEARING:**

**Modification (if any):**

**Committee Reason:** Designers should be able to design accordingly with acceptable degree of construction tolerance taking into consideration comparable vanity size. Proposed language did not establish a maximum overhang.

**604.3.1-STEINFELD.doc**

<b>Report for 06-14- 2021</b>		
<i>Committee decision: D</i>	<i>Committee Vote at Meeting: 23-2-0</i>	<i>Committee Vote on Ballot:</i>
<b>REPORT OF HEARING:</b>		
Modification (if any):		
Committee Reason: Designers should be able to design accordingly with acceptable degree of construction tolerance taking into consideration comparable vanity size. Proposed language did not establish a maximum overhang.		
<b>PUBLIC COMMENT- FIRST DRAFT:</b>		
Proponent:		
Desired Action:		
Modification:		
Reason:		
<i>Committee decision: AS/AM/D</i>	<i>Committee Vote at Meeting:</i>	<i>Committee Vote on Ballot:</i>
<b>REPORT OF HEARING – FIRST DRAFT</b>		
Modification (if any):		
Committee Reason:		
<b>PUBLIC COMMENT- SECOND DRAFT:</b>		
Proponent:		
Desired Action:		
Modification:		
Reason:		
<i>Committee decision: AS/AM/D</i>	<i>Committee Vote at Meeting:</i>	<i>Committee Vote on Ballot:</i>
<b>FINAL ACTION:</b>		
Modification (if any):		
Committee Reason:		

## 06-15 – 2021

### 604.3.3

**Proponent:** Marsha Mazz, representing United Spinal Association

**Revise as follows:**

#### SECTION 604 WATER CLOSETS AND TOILET COMPARTMENTS

##### 604.3 Clearance.

**604.3.3 Clearance overlap.** The required clearance around the water closet shall be permitted to overlap the water closet, associated grab bars, ~~paper dispensers, sanitary napkin receptacles, coat hooks, shelves,~~ accessible routes, clear floor space at other fixtures and the turning space. In addition, paper dispensers, trash receptacles, coat hooks, and shelves shall be permitted to overlap 4 inches (100 mm) maximum into the water closet clearance. No other fixtures or obstructions shall be located within the required water closet clearance.

---

**REASON:** In our inspections, Accessibility Services has observed that very large paper dispensers, trash receptacles, coat hooks, and shelves often obstruct access to the water closet and also can interfere with the legs of a person seated on the water closet. We believe that if these elements are to be permitted in the clearance, a 4-inch overlap should be sufficient to accommodate them – anything more is a potential obstruction limiting access to the water closet and reducing the maneuvering space around it.

We replace the term “sanitary napkin receptacles” with “trash receptacles” so that they are not prohibited in the water closet clearance in toilet rooms for men.

**Committee Action:** As Modified 29-3-1

##### REPORT OF HEARING:

**Modification (if any):**

**Further modify as follows:**

**604.3.3 Clearance overlap.** The required clearance around the water closet shall be permitted to overlap the water closet, associated grab bars, accessible routes, clear floor space at other fixtures and the turning space. In addition, paper dispensers, trash receptacles, coat hooks, and shelves shall be permitted to overlap 4-6 inches (100 +50 mm) maximum into the water closet clearance. No other fixtures or obstructions shall be located within the required water closet clearance.

**Committee Reason:** The modification from 4” to 6” was to allow for standard paper rolls and their dispensers – 4” would be too tight. The proposal will provide a limit on the possible obstructions caused by these elements within the clear floor space for a water closet.

604.3.3-MAZZ.doc

<b>Report for 06-15– 2021</b>		
<b>Committee decision: AM</b>	<b>Committee Vote at Meeting: 29-3-1</b>	<b>Committee Vote on Ballot:</b>
<b>REPORT OF HEARING:</b>		
Modification (if any):		
<b>Further modify as follows:</b>		
<b>604.3.3 Clearance overlap.</b> The required clearance around the water closet shall be permitted to overlap the water closet, associated grab bars, accessible routes, clear floor space at other fixtures and the turning space. In addition, paper dispensers, trash receptacles, coat hooks, and shelves shall be permitted to overlap 4-6 inches (100-150 mm) maximum into the water closet clearance. No other fixtures or obstructions shall be located within the required water closet clearance.		
Committee Reason: The modification from 4” to 6” was to allow for standard paper rolls and their dispensers – 4” would be too tight. The proposal will provide a limit on the possible obstructions caused by these elements within the clear floor space for a water closet.		
<b>PUBLIC COMMENT- FIRST DRAFT:</b>		
Proponent:		
Desired Action:		
Modification:		
Reason:		
<b>Committee decision: AS/AM/D</b>	<b>Committee Vote at Meeting:</b>	<b>Committee Vote on Ballot:</b>
<b>REPORT OF HEARING – FIRST DRAFT</b>		
Modification (if any):		
Committee Reason:		
<b>PUBLIC COMMENT- SECOND DRAFT:</b>		
Proponent:		
Desired Action:		
Modification:		
Reason:		
<b>Committee decision: AS/AM/D</b>	<b>Committee Vote at Meeting:</b>	<b>Committee Vote on Ballot:</b>
<b>FINAL ACTION:</b>		
Modification (if any):		
Committee Reason:		

**06-16 – 2021**  
**604.3.3**

**Proponent:** Gene Boecker, Code Consultants, Inc.

**Revise as follows:**

**SECTION 604**  
**WATER CLOSETS AND TOILET COMPARTMENTS**

**604.3 Clearance.**

**604.3.3 Clearance overlap.** The required clearance around the water closet shall be permitted to overlap the water closet, associated grab bars, paper dispensers, sanitary napkin receptacles, coat hooks, open or enclosed shelves, medical and security alert devices, accessible routes, clear floor space at other fixtures and the turning space. No other fixtures or obstructions shall be within the required water closet clearance.

---

**REASON:** Two additional notations need to be included in the list.

First, there should be no difference between an open shelf and an enclosed shelf like that of a wall cabinet. This has been interpretive in the past but should be clear. The depth of such shelves is not addressed. Perhaps the committee should include some limitation of the depth of the shelf or location so that it is not an obstruction.

Second, in medical care facilities such as hospitals, nursing homes and rehabilitation centers, it is common to have a pull cord and alert device next to the water closet. These are also provided in assisted living facilities and many large retail stores. These devices, due to their nature have typically not been an issue with enforcement agencies. However, occasionally we have seen these be forced out of the clear floor space and a series of strings and pulleys be required in its place, making its use complicated and more likely to be ineffective when needed.

**Committee Action:** As Submitted 26-3-2

**REPORT OF HEARING:**

**Modification (if any):** The proposal clarifies that the overlap could be cabinets or shelves. The medical devices are common in hospitals and nursing homes and need to be located close to the water closet.

**Committee Reason:**

**604.3.3-BOECKER.doc**

<b>Report for 06-16– 2021</b>		
<i>Committee decision: AS</i>	<i>Committee Vote at Meeting: 26-3-2</i>	<i>Committee Vote on Ballot:</i>
REPORT OF HEARING:		

<b>Report for 06-16- 2021</b>		
Modification (if any):		
Committee Reason: The proposal clarifies that the overlap could be cabinets or shelves. The medical devices are common in hospitals and nursing homes and need to be located close to the water closet.		
<b>PUBLIC COMMENT- FIRST DRAFT:</b>		
Proponent:		
Desired Action:		
Modification:		
Reason:		
<b>Committee decision: AS/AM/D</b>	<b>Committee Vote at Meeting:</b>	<b>Committee Vote on Ballot:</b>
<b>REPORT OF HEARING – FIRST DRAFT</b>		
Modification (if any):		
Committee Reason:		
<b>PUBLIC COMMENT- SECOND DRAFT:</b>		
Proponent:		
Desired Action:		
Modification:		
Reason:		
<b>Committee decision: AS/AM/D</b>	<b>Committee Vote at Meeting:</b>	<b>Committee Vote on Ballot:</b>
<b>FINAL ACTION:</b>		
Modification (if any):		
Committee Reason:		

# 06-18 – 2021

## 604.4, Figure 604.4

**Proponent:** Edward Steinfeld, IDEA Center, School of Architecture and Planning, University at Buffalo, State University of New York, representing RESNA

Revise as follows:

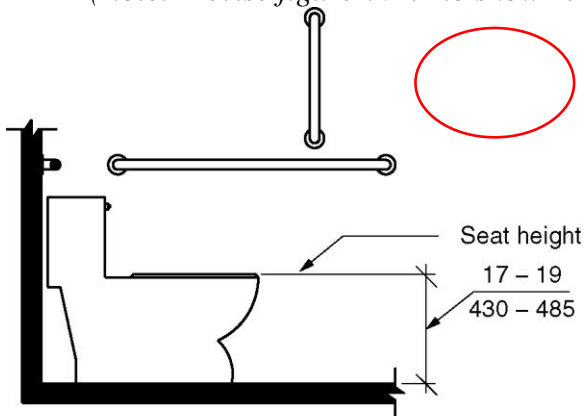
### SECTION 604 WATER CLOSETS AND TOILET COMPARTMENTS

**604.4 Height.** The height of water closet seats shall be 17 inches (430 mm) minimum ~~and to 19~~ 20 inches (485 510 mm) maximum above the floor, measured to the top of the seat. Seats shall not be sprung to return to a lifted position.

#### EXCEPTIONS:

1. An accessible water closet which is adjustable in height ~~by the user is permitted or which provides multiple hinged seats shall be permitted to provide adjustability~~ within a range of 17 inches (430 mm) minimum to 25 inches (635 mm) maximum, provided that at least one adjustment setting provides a seat within the range specified in Section 604.4.
2. A water closet in a toilet room for a single occupant, accessed only through a private office and not for common use or public use, shall not be required to comply with this section.

(Note: Revise figure 604.4 to show 17-20)



Note: For children's dimensions see Fig. 604.11.4

**FIGURE 604.4  
WATER CLOSET SEAT HEIGHT**



**REASON:** The current standard does not reflect the findings of recent research. The existing dimensions are based on 1970’s data. Since that time, new wheelchair technology, particularly the common use of cushions and other seating supports designed to reduce pressure ulcers and position people for improved social interaction and use of equipment, have led to increased seat heights. See [Design Resources: Analysis of Seat Height for Wheeled Mobility Devices at http://idea.ap.buffalo.edu/wp-content/uploads/sites/110/2019/08/23.pdf](http://idea.ap.buffalo.edu/wp-content/uploads/sites/110/2019/08/23.pdf) The above proposed revision is consistent with this research. The findings indicate that a range of 17-25 in. (430-635 mm) will accommodate almost all of the wheeled mobility population. This exception will provide guidance to manufacturers who are developing adjustable height toilets. Without this guidance, they may not address the full range of needs in the population.

**Staff Note:** Question was split between Section 604.4 and Exception 2

**Committee Action:**

Part 1- Section 604.4 As submitted 24-2-3

Part 2 – Exception 1 Disapproval 32-0-1

**REPORT OF HEARING:**

**Modification (if any):**

**Replace the proposal as follows:**

**604.4 Height.** The height of water closet seats shall be 17 inches (430 mm) minimum ~~and to 19~~ 20 inches (~~485~~ 510 mm) maximum above the floor, measured to the top of the seat. Seats shall not be sprung to return to a lifted position.

**EXCEPTIONS:**

1. An accessible water closet which is adjustable in height by the user is permitted provided that at least one adjustment setting provides a seat within the range specified in Section 604.4.
2. A water closet in a toilet room for a single occupant, accessed only through a private office and not for common use or public use, shall not be required to comply with this section.

**Committee Reason:** The committee split the proposal; with the change to 604.4 main paragraph approved and the change to the exception disapproved. The end result is a modified proposal that just change the maximum seat height to 20”. This is appropriate as it is based on Dr. Steinfeld’s research showing that the seat height for different mobility devices is higher. The specifics for the hinged seating proposed to be added in the exception was not needed as this option is already permitted in the current exception.

**604.4-STEINFELD.doc**

<b>Report for 06-18- 2021</b>		
<i>Committee decision: AM</i>	<i>Committee Vote at Meeting: 24-2-3</i>	<i>Committee Vote on Ballot:</i>
<b>REPORT OF HEARING:</b>		
Modification (if any):		

**Report for 06-18– 2021**

**Replace the proposal as follows:**

**604.4 Height.** The height of water closet seats shall be 17 inches (430 mm) minimum ~~and to 19 20~~ inches (485 510 mm) maximum above the floor, measured to the top of the seat. Seats shall not be sprung to return to a lifted position.

**EXCEPTIONS:**

1. An accessible water closet which is adjustable in height by the user is permitted provided that at least one adjustment setting provides a seat within the range specified in Section 604.4.
2. A water closet in a toilet room for a single occupant, accessed only through a private office and not for common use or public use, shall not be required to comply with this section.

Committee Reason: The committee split the proposal; with the change to 604.4 main paragraph approved and the change to the exception disapproved. The end result is a modified proposal that just change the maximum seat height to 20". This is appropriate as it is based on Dr. Steinfeld's research showing that the seat height for different mobility devices is higher. The specifics for the hinged seating proposed to be added in the exception was not needed as this option is already permitted in the current exception.

**PUBLIC COMMENT- FIRST DRAFT:**

Proponent:

Desired Action:

Modification:

Reason:

**Committee decision: AS/AM/D**

**Committee Vote at Meeting:**

**Committee Vote on Ballot:**

**REPORT OF HEARING – FIRST DRAFT**

Modification (if any):

Committee Reason:

**PUBLIC COMMENT- SECOND DRAFT:**

Proponent:

Desired Action:

Modification:

Reason:

**Committee decision: AS/AM/D**

**Committee Vote at Meeting:**

**Committee Vote on Ballot:**

**FINAL ACTION:**

Modification (if any):

Committee Reason:

## 06-19 – 2021

### 604.5.2

**Proponent:** Kyle Thompson, Plumbing Manufacturers International (PMI)

**Revise as follows:**

#### SECTION 604 WATER CLOSETS AND TOILET COMPARTMENTS

**604.5.2 Rear-wall grab bars.** The fixed rear-wall grab bar shall

1. Be 36 inches (915 mm) minimum in length,
2. Be located 6 inches maximum (150 mm) from the side wall, and
3. Extend 42 inches (1065 mm) minimum from the side wall.

**Exceptions:**

1. The rear grab bar shall be permitted to be 24 inches (610 mm) minimum in length, centered on the water closet, where wall space does not permit a grab bar 36 inches (915 mm) minimum in length due to the location of a recessed fixture adjacent to the water closet.
2. Where ~~an administrative authority requires flush~~ flushing devices and controls for flush valves to be are located in a position that conflicts with the location of the rear grab bar, that grab bar shall be permitted to be split or shifted to the open side of the toilet area.

---

**REASON:** The entire standard is under the jurisdiction of the administrative authority and it makes no sense to specify such a requirement in Exception 2. By adding “flushing devices” and striking out “flush valves” the proposed revisions clarify that Exception 2 would apply to the entire flushometer valve and flush tank, besides the controls. Proposed revisions to Exception 2 are necessary because flushometer valves have various heights because of the vacuum breakers (which are necessary for protecting the potable water supply from dirty toilet water) which can be unique per plumbing system. Furthermore, most bedpan washers in the marketplace do not fit under the rear grab bar when you factor in the height of the bedpan washer arm, vacuum breaker and location of the flush controls.

**Committee Action:** Approved as modified: 19-8-1

**REPORT OF HEARING:**

**Twice Modification (if any):** Approved 21-9-0, Approved 17-10-2

**Replace with the following:**

**604.5.2 Rear-wall grab bars.** The fixed rear-wall grab bar shall



**Report for 06-19- 2021**

<i>Committee decision: AS/AM/D</i>	<i>Committee Vote at Meeting:</i>	<i>Committee Vote on Ballot:</i>
<b>FINAL ACTION:</b>		
Modification (if any):		
Committee Reason:		

**06-20 – 2021**  
**604.6**

**Proponent:** Marsha Mazz, representing United Spinal Association

**Revise as follows:**

**SECTION 604**  
**WATER CLOSETS AND TOILET COMPARTMENTS**

**604.6 Flush controls.** Flush controls shall be hand-operated or automatic. Where only hand ~~Hand~~ operated flush controls are provided, they shall comply with Section 309. Hand-operated flush controls shall be located on the open side of the centerline of the water closet.

**Exception Exceptions:**

1. In ambulatory accessible toilet compartments complying with Section 604.10, flush controls shall be permitted to be located on either side of the water closet.
2. Hand-operated flush controls shall be permitted to cross the centerline of the water closet, provided that the portion of the control that is located to the open side of the centerline independently complies with Section 309.4.

---

**REASON:** This proposal accomplishes two things. First, it clarifies that where automatic flush controls are provided, the override button, sometimes called a courtesy button, near not be accessible. While this seems picayune, the inspectors in at least one large city have interpreted the requirement, as written, to apply to these small buttons which typically are not accessible.

Second, the proposal clarifies that a type of control that is common for dual flush toilets is compliant if a portion of the control is located to the open side of the water closet and is operable in compliance with the force requirements of Section 309.4.

**Committee Action:** 24-0-1 As Submitted

**REPORT OF HEARING:**

**Modification (if any):**

**Committee Reason:** The proposal allows for the types of controls that are on the top of tanks or on the wall over the water closet. This also clarifies that the automatic controls can be centered since they do not require activation by the user.

**604.6-MAZZ.doc**

<b>Report for 06-20– 2021</b>		
<b>Committee decision:</b> AS	<b>Committee Vote at Meeting:</b> 24-0-1	<b>Committee Vote on Ballot:</b>
<b>REPORT OF HEARING:</b>		
Modification (if any):		
Committee Reason: The proposal allows for the types of controls that are on the top of tanks or on the wall over the water closet. This also clarifies that the automatic controls can be centered since they do not require activation by the user.		
<b>PUBLIC COMMENT- FIRST DRAFT:</b>		
Proponent:		



<b>Report for 06-20- 2021</b>		
Desired Action:		
Modification:		
Reason:		
<b>Committee decision: AS/AM/D</b>	<b>Committee Vote at Meeting:</b>	<b>Committee Vote on Ballot:</b>
<b>REPORT OF HEARING – FIRST DRAFT</b>		
Modification (if any):		
Committee Reason:		
<b>PUBLIC COMMENT- SECOND DRAFT:</b>		
Proponent:		
Desired Action:		
Modification:		
Reason:		
<b>Committee decision: AS/AM/D</b>	<b>Committee Vote at Meeting:</b>	<b>Committee Vote on Ballot:</b>
<b>FINAL ACTION:</b>		
Modification (if any):		
Committee Reason:		

**06-21 – 2021**  
**604.6**

**Proponent:** Kyle Thompson, Plumbing Manufacturers International (PMI)

**Revise as follows:**

**SECTION 604**  
**WATER CLOSETS AND TOILET COMPARTMENTS**

**604.6 Flush controls.** Flush controls shall be hand operated or automatic. Hand operated flush controls shall comply with Section 309. Flush controls shall be located on the open side of the water closet. Hand operated flush controls must be usable from a point between the centerline and the open side of the fixture. A portion of the control can be outside the range where it is usable without having to reach beyond the water closet centerline from the open side.

**Exception:** In ambulatory accessible toilet compartments complying with Section 604.10, flush controls shall be permitted to be located on either side of the water closet.

**REASON:** Are flush controls located on valves, walls, or tanks that are centered on the fixture compliant (i.e., on the open side)?

Manual flush controls, including push buttons, must be usable from a point between the centerline and the open side of the fixture. A portion of the control can be outside the range if it is usable without having to reach beyond the water closet centerline from the open side. To see the interpretation, go to: [Chapter 6: Toilet Rooms \(access-board.gov\)](http://access-board.gov)

**Committee Action:** 23-2-1 Disapproved

**REPORT OF HEARING:**

**Modification (if any):**

**Committee Reason:** This proposal was disapproved because the committee preferred the resolution for center controls on water closets provided in 06-20-2021.

**604.6-THOMPSON.doc**

<b>Report for 06-21-2021</b>		
<i>Committee decision: D</i>	<i>Committee Vote at Meeting: 23-2-1</i>	<i>Committee Vote on Ballot:</i>
<b>REPORT OF HEARING:</b>		
Modification (if any):		
Committee Reason: This proposal was disapproved because the committee preferred the resolution for center controls on water closets provided in 06-20-2021.		
<b>PUBLIC COMMENT- FIRST DRAFT:</b>		
Proponent:		
Desired Action:		
Modification:		
Reason:		
<i>Committee decision: AS/AM/D</i>	<i>Committee Vote at Meeting:</i>	<i>Committee Vote on Ballot:</i>

<b>Report for 06-21-2021</b>		
<b>REPORT OF HEARING – FIRST DRAFT</b>		
Modification (if any):		
Committee Reason:		
<b>PUBLIC COMMENT- SECOND DRAFT:</b>		
Proponent:		
Desired Action:		
Modification:		
Reason:		
<b>Committee decision: AS/AM/D</b>	<b>Committee Vote at Meeting:</b>	<b>Committee Vote on Ballot:</b>
<b>FINAL ACTION:</b>		
Modification (if any):		
Committee Reason:		

**06-22 – 2021**  
**604.9.1**

**Proponent:** Gene Boecker, Code Consultants, Inc.

**Revise as follows:**

**SECTION 604**  
**WATER CLOSETS AND TOILET COMPARTMENTS**

**604.9 Wheelchair accessible toilet compartments.**

**604.9.1 General.** Wheelchair accessible toilet compartments shall comply with Section 604.9.

**Exception:** Toilet compartments shall be permitted to comply with Section 603.

**REASON:** The primary reason for the toilet compartment dimensions is because turning requires a toe clearance that extends under the partitions. Even with an expanded compartment a true turning space is not provided. However, if a true turning space is provided, the compartment is large enough to be considered a room. In such a case the option of an in-swinging door complying with Section 603.2.2 should be allowed, regardless of the number of fixtures within the compartment.

**Committee Action:** 23-1-4 Disapproved

**REPORT OF HEARING:**

**Modification (if any):**

**Committee Reason:** This reference is already in Section 604.1. Adding it here under compartments would be confusing.

**604.9.1-BOECKER.doc**

<b>Report for 06-22– 2021</b>		
<i>Committee decision: D</i>	<i>Committee Vote at Meeting: 23-1-4</i>	<i>Committee Vote on Ballot:</i>
<b>REPORT OF HEARING:</b>		
Modification (if any):		
Committee Reason: This reference is already in Section 604.1. Adding it here under compartments would be confusing.		
<b>PUBLIC COMMENT- FIRST DRAFT:</b>		
Proponent:		
Desired Action:		
Modification:		
Reason:		
<i>Committee decision: AS/AM/D</i>	<i>Committee Vote at Meeting:</i>	<i>Committee Vote on Ballot:</i>
<b>REPORT OF HEARING – FIRST DRAFT</b>		
Modification (if any):		
Committee Reason:		
<b>PUBLIC COMMENT- SECOND DRAFT:</b>		
Proponent:		
Desired Action:		
Modification:		
Reason:		
<i>Committee decision: AS/AM/D</i>	<i>Committee Vote at Meeting:</i>	<i>Committee Vote on Ballot:</i>

**Report for 06-22– 2021**

**FINAL ACTION:**

Modification (if any):

Committee Reason:

## 06-23 – 2021

### 604.9.3, Figures 604.9.2.3, 604.9.3(B)

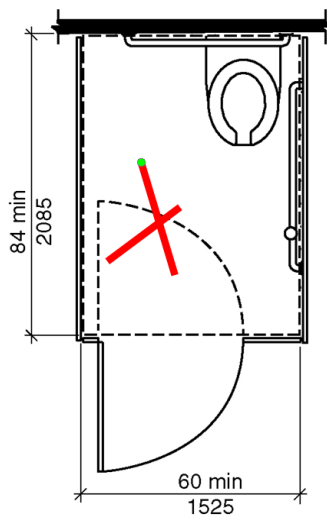
**Proponent:** Gina Hilberry, Cohen Hilberry Architects, representing United Cerebral Palsy

**Revise as follows:**

#### SECTION 604 WATER CLOSETS AND TOILET COMPARTMENTS

##### 604.9 Wheelchair accessible toilet compartments.

**604.9.2.3 Alternate wheelchair accessible toilet compartments.** Where an alternate wheelchair accessible toilet compartment is provided, the minimum area of the compartment shall be 60 inches (1525 mm) minimum in width, measured perpendicular to the side wall, and 84 inches (2135 mm) minimum in depth, measured perpendicular to the rear wall.



**Figure 604.9.2.3**  
**WHEELCHAIR TOILET COMPARTMENTS**  
**ALTERNATE WHEELCHAIR TOILET COMPARTMENT**

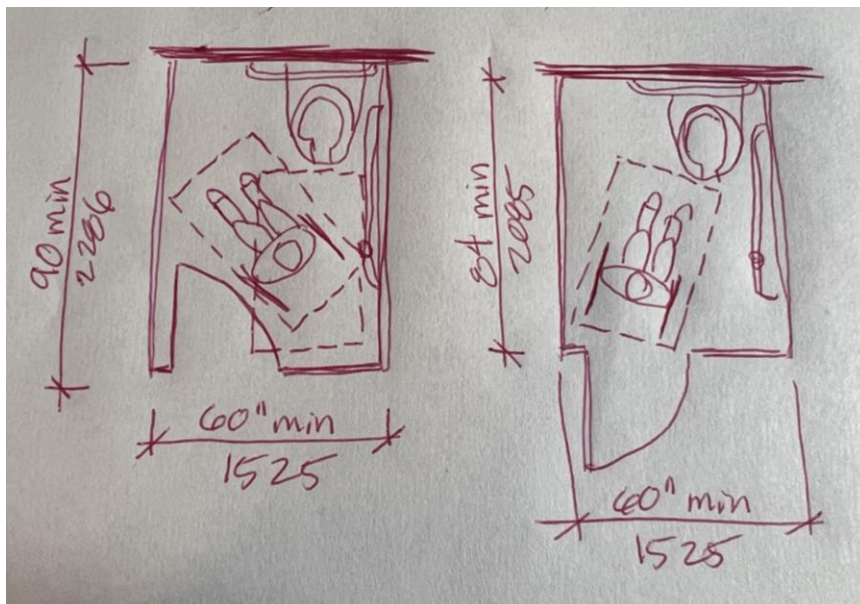
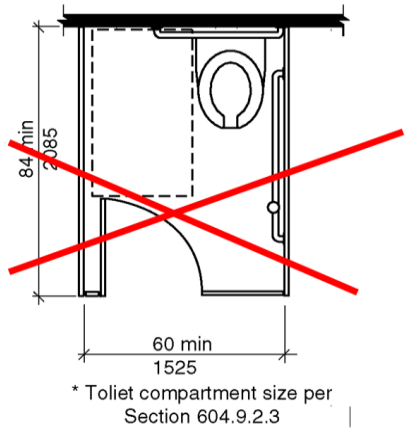
**604.9.3 Doors.** Wheelchair accessible toilet compartment doors, including door hardware, shall comply with Section 404. The door shall be self-closing. A door pull complying with Section 404.2.6 shall be placed on both sides of the door near the latch. Wheelchair accessible toilet compartment doors shall not swing into the required minimum area of the compartment.

**Exceptions:**

1. Outside of the compartment, where the approach is to the latch side of the wheelchair accessible toilet compartment, door clearance between the door side of the compartment and any obstruction shall be 42 inches (1065 mm) minimum.



2. Within the wheelchair accessible toilet compartment, maneuvering clearances at the door shall not be required to comply with Section 404.
3. In an alternate wheelchair accessible toilet compartment, the door shall be permitted to swing into the stall compartment where the minimum depth of the stall is 90 inches (2286 mm) ~~a clear floor space complying with Section 305.3 is provided within the stall beyond the arc of the door swing.~~



**Figure 604.9.3(B)**  
**Wheelchair Toilet Compartment Doors**  
**Exception 3 – Alternate Wheelchair Compartment**

**REASON:** The intent of the alternate wheelchair toilet compartment is to allow for use of the toilet with a forward transfer while maintaining the ability to close door for privacy. For this to work, the person must be able to position themselves directly in front of the toilet without

obstructing the door swing. In a standard wheelchair compartment, it is impossible to close the door with a wheelchair extending straight out from the toilet.

Forward approach to the toilet fixture is used frequently by people who cannot complete a side transfer due to physical needs or due to equipment limitations. While not the most common transfer method, it is common for people with cerebral palsy. UCP was the original proponent for this compartment design and this revision clarifies the technical issues incorporated into the design during the end of the 2017 review process.

This change is about ease of use and maneuvering. An alcove requires a 60 length. The space in front of the water closet would be considered confined on three sides. The current depth would allow for an angles front approach with the door swinging out but would be tight for directly in front (29" toilet + 52" clear floor space = 81"). The 84" depth is 5" short of the alcove, but the door swinging out should allow access. If the door swings in, in order to get past the swing of the door, and allow for the alcove length, the depth of the stall would be 90 inches (29" toilet + 60" alcove = 79"). Most water closets are 22" to 29" deep.

Scoping for this alternate wheelchair toilet compartment is submitted separately.

**Committee Action:** 22-4-1 As Submitted

**REPORT OF HEARING:**

**Modification (if any):**

**Further modify as follows (editorial):**

**604.9.3 Doors.** Wheelchair accessible toilet compartment doors, including door hardware, shall comply with Section 404. The door shall be self-closing. A door pull complying with Section 404.2.6 shall be placed on both sides of the door near the latch. Wheelchair accessible toilet compartment doors shall not swing into the required minimum area of the compartment.

**Exceptions:**

1. Outside of the compartment, where the approach is to the latch side of the wheelchair accessible toilet compartment, door clearance between the door side of the compartment and any obstruction shall be 42 inches (1065 mm) minimum.
2. Within the wheelchair accessible toilet compartment, maneuvering clearances at the door shall not be required to comply with Section 404.
3. In an alternate wheelchair accessible toilet compartment, the door shall be permitted to swing into the ~~stall~~ compartment where the minimum depth of the stall is 90 inches (2286 mm).

**Committee Reason:** There was an editorial modification to change ‘stall’ to ‘compartment’ for consistency with the terminology for water closet compartments. The modification will allow for the person to using the wheelchair to get in front of the water closet for a front transfer without interference from the compartment door.

**604.9.2.3 fig-HILBERRY.doc**

<b>Report for 06-23- 2021</b>		
<i>Committee decision: AS</i>	<i>Committee Vote at Meeting: 22-4-1</i>	<i>Committee Vote on Ballot:</i>
<b>REPORT OF HEARING:</b>		

**Report for 06-23– 2021**

Modification (if any):

**Further modify as follows (editorial):**

**604.9.3 Doors.** Wheelchair accessible toilet compartment doors, including door hardware, shall comply with Section 404. The door shall be self-closing. A door pull complying with Section 404.2.6 shall be placed on both sides of the door near the latch. Wheelchair accessible toilet compartment doors shall not swing into the required minimum area of the compartment.

**Exceptions:**

1. Outside of the compartment, where the approach is to the latch side of the wheelchair accessible toilet compartment, door clearance between the door side of the compartment and any obstruction shall be 42 inches (1065 mm) minimum.
2. Within the wheelchair accessible toilet compartment, maneuvering clearances at the door shall not be required to comply with Section 404.
3. In an alternate wheelchair accessible toilet compartment, the door shall be permitted to swing into the **stall compartment** where the minimum depth of the stall is 90 inches (2286 mm).

Committee Reason: There was an editorial modification to change 'stall' to 'compartment' for consistency with the terminology for water closet compartments. The modification will allow for the person to using the wheelchair to get in front of the water closet for a front transfer without interference from the compartment door.

**PUBLIC COMMENT- FIRST DRAFT:**

Proponent:

Desired Action:

Modification:

Reason:

**Committee decision: AS/AM/D****Committee Vote at Meeting:****Committee Vote on Ballot:****REPORT OF HEARING – FIRST DRAFT**

Modification (if any):

Committee Reason:

**PUBLIC COMMENT- SECOND DRAFT:**

Proponent:

Desired Action:

Modification:

Reason:

**Committee decision: AS/AM/D****Committee Vote at Meeting:****Committee Vote on Ballot:****FINAL ACTION:**

Modification (if any):

Committee Reason:

# 06-24 – 2021

## 604.9.3

**Proponent:** Kimberly Paarlberg, International Code Council

**Revise as follows:**

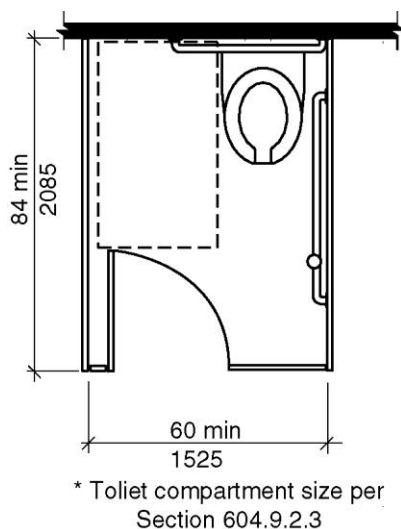
### SECTION 604 WATER CLOSETS AND TOILET COMPARTMENTS

#### 604.9 Wheelchair accessible toilet compartments.

**604.9.3 Doors.** Wheelchair accessible toilet compartment doors, including door hardware, shall comply with Section 404. The door shall be self-closing. A door pull complying with Section 404.2.6 shall be placed on both sides of the door near the latch. Wheelchair accessible toilet compartment doors shall not swing into the required minimum area of the compartment.

**Exceptions:**

1. Outside of the compartment, where the approach is to the latch side of the wheelchair accessible toilet compartment, door clearance between the door side of the compartment and any obstruction shall be 42 inches (1065 mm) minimum.
2. Within the wheelchair accessible toilet compartment, maneuvering clearances at the door shall not be required to comply with Section 404.
3. In an alternate wheelchair accessible toilet compartment complying with Section 604.9.2.3, a door located in the front wall or partition ~~the door~~ shall be permitted to swing into the stall where a clear floor space complying with Section 305.3 is provided within the stall beyond the arc of the door swing.



**FIGURE 604.9.3(B)**

**WHEELCHAIR TOILET COMPARTMENT DOORS  
EXCEPTION 3 – ALTERNATE WHEELCHAIR TOILET COMPARTMENT**

**REASON:** When the “alternate” compartment requirements were added into the 2017 the original intent of the proponent was to allow for a larger size compartment that might allow the mobility-device user to do a forward approach to the water closet while being able to close the compartment door for privacy. The standard compartment is set up only for a transfer from the side. As a part of the committee’s revisions they looked at the prohibition of doors swinging into the minimum-sized compartment. Because of the larger depth in front of the water closet, the availability of a clear floor space beside the fixture, and the increased space for maneuvering within the compartment, the committee added what is shown as the existing Exception 3.

This proposal ties and limits the third exception directly to the alternate compartment provisions of Section 604.9.2.3 and ensures that the door is located to allow a user to move straight into the stall. Without a limitation for the door to be located in the front wall (as was the original intent), Section 604.9.3.1 could be used to allow a side wall door. Again the original proponent and the committee were expecting the door for the “alternate” compartment to be located as shown in Figure 604.9.3(B) and to allow the user to move directly into the compartment and to allow a forward approach to the water closet.

By specifically referencing Section 604.9.2.3, the exception will clearly indicate when it is permitted to be used. This will ensure the exception is limited to the compartment configuration that was intended and that it is not used for other “alternate” (atypical) designs such as what is shown in Figure 604.9.3(A). Because a code user may select and use any of the exceptions, it is important that Exception 3 be limited to the specific alternate configuration which was intended and not be applied to other configurations which were not discussed and may not adequately address maneuvering within the compartment.

Without the added text of this proposal, there is nothing that specifically addresses the compartment size or configuration and therefore the exception could be viewed as having broader application, or other configurations such as a side wall door could be used for the alternate compartment, even though that was never proposed, discussed or anticipated.

**Committee Action:** 18-8-0 As Submitted

**REPORT OF HEARING:**

**Modification (if any):**

**Committee Reason:** This proposal ties and limits the third exception directly to the alternate compartment provisions of Section 604.9.2.3 and ensures that the door is located to allow a user to move straight into the stall.

**604.9.3-PAARLBERG.doc**

<b>Report for <del>06-24-</del> 2021</b>		
<b>Committee decision:</b> AS	<b>Committee Vote at Meeting:</b> 18-8-0	<b>Committee Vote on Ballot:</b>
<b>REPORT OF HEARING:</b>		
Modification (if any):		
Committee Reason: This proposal ties and limits the third exception directly to the alternate compartment provisions of Section 604.9.2.3 and ensures that the door is located to allow a user to move straight into the stall.		

<b>Report for 06-24- 2021</b>		
<b>PUBLIC COMMENT- FIRST DRAFT:</b>		
Proponent:		
Desired Action:		
Modification:		
Reason:		
<i>Committee decision: AS/AM/D</i>	<i>Committee Vote at Meeting:</i>	<i>Committee Vote on Ballot:</i>
<b>REPORT OF HEARING – FIRST DRAFT</b>		
Modification (if any):		
Committee Reason:		
<b>PUBLIC COMMENT- SECOND DRAFT:</b>		
Proponent:		
Desired Action:		
Modification:		
Reason:		
<i>Committee decision: AS/AM/D</i>	<i>Committee Vote at Meeting:</i>	<i>Committee Vote on Ballot:</i>
<b>FINAL ACTION:</b>		
Modification (if any):		
Committee Reason:		

**06-26-2021**  
**604.9.5.1**

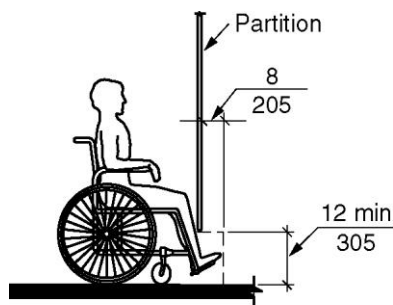
**Proponent:** Kimberly Paarlberg, International Code Council

**Revise text as follows:**

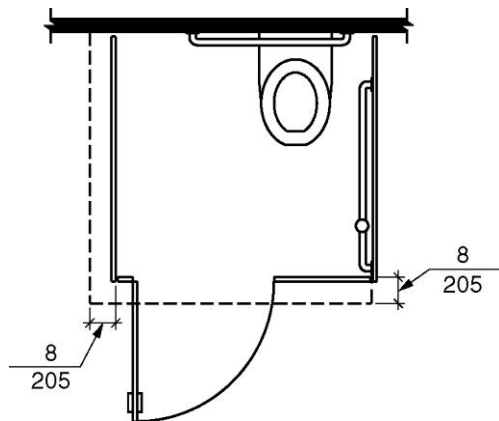
**SECTION 604**  
**WATER CLOSETS AND TOILET COMPARTMENTS**

**604.9 Wheelchair accessible toilet compartments.**

**604.9.5 Toe clearance.** Toe clearance for wheelchair accessible toilet compartments primarily for children's use shall comply with Section 604.9.5.2. Toe clearance for other wheelchair accessible toilet compartments shall comply with Section 604.9.5.1.



**FIGURE 604.9.5(A)**  
**TOE CLEARANCE - ELEVATION**



**FIGURE 604.9.5(B)**  
**TOE CLEARANCE – PLAN**



**604.9.5.1 Toe clearance at wheelchair accessible toilet compartments and alternate wheelchair accessible toilet compartments.** The front partition and at least one side partition of wheelchair accessible toilet compartments and alternate wheelchair accessible toilet compartments shall provide a toe clearance of 12 inches (305 mm) minimum above the floor and extending 8 inches (205 mm) beyond the compartment side face of the partition, exclusive of partition support members.

**Exceptions:**

1. Toe clearance at the front partition is not required in a wheelchair accessible toilet compartment or alternate wheelchair accessible toilet compartments greater than 64 inches (1625 mm) in depth with a wall-hung water closet, or greater than 67 inches (1700 mm) in depth with a floor-mounted water closet.
2. Toe clearance at the side partition is not required in a wheelchair accessible toilet compartment or alternate wheelchair accessible toilet compartments greater than 68 inches (1725 mm) in width.

**REASON:** The purpose of this proposal is to clarify the partition requirements for the new alternate stall since the toe clearance is required. This would cover the stall with the door swinging in in Section 604.9.3(B).

**Committee Action:** 23-2-4 As Submitted

**REPORT OF HEARING:**

**Modification (if any):**

**Committee Reason:** The proposal clarifies the partition requirements for the new alternate stall since the toe clearance is required.

**604.9.5.1-PAARLBERG.doc**

<b>Report for 06-26- 2021</b>		
<b>Committee decision: AS</b>	<b>Committee Vote at Meeting: 23-2-4</b>	<b>Committee Vote on Ballot:</b>
<b>REPORT OF HEARING:</b>		
Modification (if any):		
Committee Reason: The proposal clarifies the partition requirements for the new alternate stall since the toe clearance is required.		
<b>PUBLIC COMMENT- FIRST DRAFT:</b>		
Proponent:		
Desired Action:		
Modification:		
Reason:		
<b>Committee decision: AS/AM/D</b>	<b>Committee Vote at Meeting:</b>	<b>Committee Vote on Ballot:</b>
<b>REPORT OF HEARING – FIRST DRAFT</b>		
Modification (if any):		
Committee Reason:		
<b>PUBLIC COMMENT- SECOND DRAFT:</b>		
Proponent:		
Desired Action:		
Modification:		
Reason:		
<b>Committee decision: AS/AM/D</b>	<b>Committee Vote at Meeting:</b>	<b>Committee Vote on Ballot:</b>
<b>FINAL ACTION:</b>		
Modification (if any):		
Committee Reason:		

**06-27 – 2021**  
**604.9.5.1, 604.9.5.2**

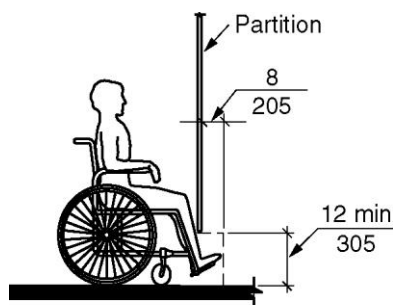
**Proponent:** Kimberly Paarlberg, International Code Council

**Revise as follows:**

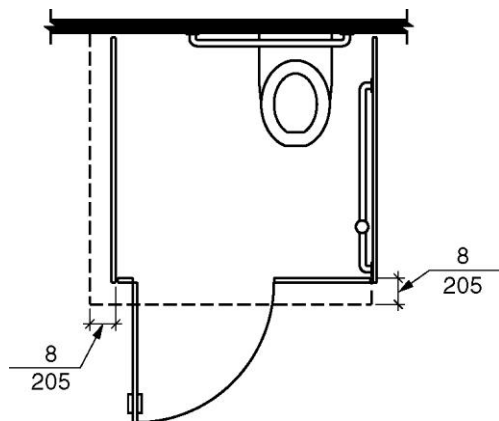
**SECTION 604**  
**WATER CLOSETS AND TOILET COMPARTMENTS**

**604.9 Wheelchair accessible toilet compartments.**

**604.9.5 Toe clearance.** Toe clearance for wheelchair accessible toilet compartments primarily for children's use shall comply with Section 604.9.5.2. Toe clearance for other wheelchair accessible toilet compartments shall comply with Section 604.9.5.1.



**FIGURE 604.9.5(A)**  
**TOE CLEARANCE - ELEVATION**



**FIGURE 604.9.5(B)**  
**TOE CLEARANCE – PLAN**

#### **604.9.5.1 Toe clearance at wheelchair accessible toilet compartments**

The front partition and at least one side partition of wheelchair accessible toilet compartments shall provide a toe clearance of 12 inches (305 mm) minimum above the floor and extending 8 inches (205 mm) beyond the compartment side face of the partition, exclusive of partition support members.

##### **Exceptions:**

1. Toe clearance at the front partition is not required in a wheelchair accessible toilet compartment greater than 64 inches (1625 mm) in depth with a wall-hung water closet, or greater than 67 inches (1700 mm) in depth with a floor-mounted water closet.
2. Toe clearance at the side partition is not required in a wheelchair accessible toilet compartment greater than 68 inches (1725 mm) in width.
3. Toe clearance is not required in a wheelchair accessible compartment that includes a turning space complying with Section 304.

#### **604.9.5.2 Toe clearance at wheelchair accessible toilet compartments for children's use.**

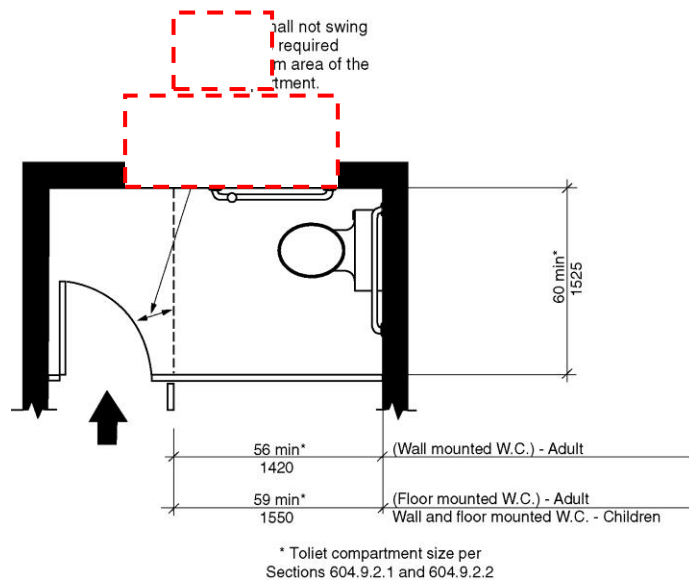
The front partition and at least one side partition of wheelchair accessible toilet compartments primarily for children's use shall provide a toe clearance of 12 inches (305 mm) minimum above the floor and extending 8 inches (205 mm) beyond the wheelchair accessible toilet compartment side face of the partition, exclusive of partition support members.

##### **Exceptions:**

1. Toe clearance at the front partition is not required in a wheelchair accessible toilet compartment greater than 67 inches (1700 mm) in depth.
2. Toe clearance at the side partition is not required in a wheelchair accessible toilet compartment greater than 68 inches (1725 mm) in width.
3. Toe clearance is not required in a wheelchair accessible compartment that includes a turning space complying with Section 304.

---

**REASON:** Where a turning space is located within the wheelchair toilet compartment, the need for the toe clearances at the front and one side privacy partition is not warranted. This proposal will be conducive for the popular "end-stall" configuration where the privacy partition extends down to the floor, which are becoming more popular especially with the advent of "universal" multi-user restroom which may be used by all persons regardless of sex, gender or affiliations.



**Committee Action:** 20-4-4 As Submitted

**REPORT OF HEARING:**

**Modification (if any):**

**Committee Reason:** The committee felt that where a turning space was provided within a compartment, that the additional width or length required in Exception 1 and 2 were not needed. This will increase design options.

**604.9.5.1-2-PAARLBERG.doc**

<b>Report for 06-27- 2021</b>		
<b>Committee decision: AS</b>	<b>Committee Vote at Meeting: 20-4-4</b>	<b>Committee Vote on Ballot:</b>
<b>REPORT OF HEARING:</b>		
Modification (if any):		
Committee Reason: The committee felt that where a turning space was provided within a compartment, that the additional width or length required in Exception 1 and 2 were not needed. This will increase design options.		
<b>PUBLIC COMMENT- FIRST DRAFT:</b>		
Proponent:		
Desired Action:		
Modification:		
Reason:		
<b>Committee decision: AS/AM/D</b>	<b>Committee Vote at Meeting:</b>	<b>Committee Vote on Ballot:</b>
<b>REPORT OF HEARING – FIRST DRAFT</b>		
Modification (if any):		
Committee Reason:		
<b>PUBLIC COMMENT- SECOND DRAFT:</b>		
Proponent:		
Desired Action:		
Modification:		
Reason:		
<b>Committee decision: AS/AM/D</b>	<b>Committee Vote at Meeting:</b>	<b>Committee Vote on Ballot:</b>
<b>FINAL ACTION:</b>		
Modification (if any):		
Committee Reason:		

# 06-28 – 2021

## 604.9.7 (New)

**Proponent:** Gene Boecker, Code Consultants, Inc.

**Add new text as follows:**

### SECTION 604 WATER CLOSETS AND TOILET COMPARTMENTS

#### 604.9 Wheelchair accessible toilet compartments.

**604.9.7 Identification.** The wheelchair accessible compartment shall be identified with the International Symbol for Accessibility complying with Section 703.6.3.1.

---

**REASON:** In a typical toilet room, the accessible compartment was usually identified by the wide door and extra wide blank panel next to it. However, recent design changes with full height panels or walls with standard doors and lever set hardware have created the condition where it is a game of hide and seek to find behind which door is the large compartment with grab bars. The trend toward gender neutral toilet rooms has led to designs with common lavatory areas and toilet compartments which are enclosed by walls and doors.

This is a similar provision to that for checkout aisles. Where not all the accessible, something needs to be done to identify the accessible element without trying to open all the doors.

Notes 9-22-2022: Committee discussed if the compartments should be identified. Moved to end of Chapter 6 or until the Communications task group has a symbol suggestion, whichever comes first.

**Committee Action:** Disapprove 25-2-2

#### REPORT OF HEARING:

##### Modification (if any):

**Committee Reason:** The committee was split on if this is designating a room or space, so it was not clear if this would have to meet all the signage requirements including raised, braille and placement next to the compartment door. Putting this identification on the compartment could be read to be wheelchairs only, like parking. There are no clear requirements for size or location. Is this really a problem? The wheelchair stall is already easily identifiable by the wider door.

**604.9-BOECKER.doc**

Report for 06-28– 2021		
Committee decision: D	Committee Vote at Meeting: 25-2-2	Committee Vote on Ballot:
REPORT OF HEARING: The committee was split on if this is designating a room or space, so it was not clear if this would have to meet all the		

**Report for 06-28- 2021**

signage requirements including raised, braille and placement next to the compartment door. Putting this identification on the compartment could be read to be wheelchairs only, like parking. There are no clear requirements for size or location. Is this really a problem? The wheelchair stall is already easily identifiable by the wider door.

Modification (if any):

Committee Reason:

**PUBLIC COMMENT- FIRST DRAFT:**

Proponent:

Desired Action:

Modification:

Reason:

*Committee decision: AS/AM/D*

*Committee Vote at Meeting:*

*Committee Vote on Ballot:*

**REPORT OF HEARING – FIRST DRAFT**

Modification (if any):

Committee Reason:

**PUBLIC COMMENT- SECOND DRAFT:**

Proponent:

Desired Action:

Modification:

Reason:

*Committee decision: AS/AM/D*

*Committee Vote at Meeting:*

*Committee Vote on Ballot:*

**FINAL ACTION:**

Modification (if any):

Committee Reason:

# 06-29 – 2021

## 604.10.5(New), 604.10.6(New)

**Proponent:** Gene Boecker, Code Consultants, Inc.

### SECTION 604 WATER CLOSETS AND TOILET COMPARTMENTS

#### 604.10 Ambulatory accessible toilet compartments.

**Add new text as follows:**

**604.10.5. Height.** The height of water closet seats shall comply with Section 604.4.

**604.10.6 Dispensers.** Toilet paper dispensers shall comply with Section 604.7.

---

**REASON:** The height of the seat in the ambulatory compartment is interpreted as being the same as that for the wheelchair accessible compartment since the provisions are all in Section 604. The same is true for the toilet paper dispenser. The reasons for their placement is the specific locations is applicable to individuals needing both types of fixtures. However, because the wheelchair accessible compartment is deemed “accessible” the ambulatory compartment often does not get the same recognition. We frequently see these two elements improperly installed. If a little more ink will make it clear that the intent is the same for the ambulatory compartment as the wheelchair compartment, it will be a big help to proper installations.

**Committee Action:** 17-6-4 As Submitted

#### REPORT OF HEARING:

**Modification (if any):**

**Committee Reason:** The additional sections will provide references for items that are commonly missed for ambulatory compartments. However, there was a request to make this a complete list for ambulatory compartment requirements.

**604.10-BOECKER.doc**

Report for 06-29– 2021		
Committee decision: AS	Committee Vote at Meeting: 17-6-4	Committee Vote on Ballot:
<b>REPORT OF HEARING:</b>		
Modification (if any):		
Committee Reason: The additional sections will provide references for items that are commonly missed for ambulatory compartments. However, there was a request to make this a complete list for ambulatory compartment requirements.		
<b>PUBLIC COMMENT- FIRST DRAFT:</b>		
Proponent:		
Desired Action:		
Modification:		
Reason:		
Committee decision: AS/AM/D	Committee Vote at Meeting:	Committee Vote on Ballot:



<b>Report for 06-29- 2021</b>		
<b>REPORT OF HEARING – FIRST DRAFT</b>		
Modification (if any):		
Committee Reason:		
<b>PUBLIC COMMENT- SECOND DRAFT:</b>		
Proponent:		
Desired Action:		
Modification:		
Reason:		
<b>Committee decision: AS/AM/D</b>	<b>Committee Vote at Meeting:</b>	<b>Committee Vote on Ballot:</b>
<b>FINAL ACTION:</b>		
Modification (if any):		
Committee Reason:		

**06-30 – 2021**

**604.10.5(New), 703.6.3.5(New), Figure 703.6.3.5(New)**

**Proponent:** Gene Boecker, Code Consultants, Inc.

**SECTION 604  
WATER CLOSETS AND TOILET COMPARTMENTS**

**Add new text as follows:**

**604.10 Ambulatory accessible toilet compartments.**

**604.10.5 Identification.** The ambulatory stall shall be identified with the United Nations Symbol for Elderly complying with Section 703.6.3.5.

**703.6 Symbols of accessibility.**

**703.6.3.5 Symbol for the elderly.** The ambulatory stall shall be identified by the United Nations Symbol for the Elderly complying with Figure 703.6.3.5



**FIGURE 703.6.3.5  
UNITED NATIONS SYMBOL FOR THE ELDERLY**

---

**REASON:** In a typical toilet room, the ambulatory compartment was usually identified by the wide out-swinging door and loop handle. However, recent design changes with full height panels or walls with standard doors and lever set hardware have created the condition where it is a game of hide and seek to find behind which door is the ambulatory compartment. The trend toward gender neutral toilet rooms has led to designs with common lavatory areas and toilet compartments which are enclosed by walls and doors.

This is a similar provision to that for checkout aisles. Where not all the accessible, something needs to be done to identify the accessible element without trying to open all the doors.

A new symbol is being proposed for inclusion as a result of the need to identify the ambulatory compartment. This symbol is the recommended symbol for “elderly” according to the United Nations Office for the Coordination of Humanitarian Affairs (UNOCHA). After a search of multiple symbols for this use, the most easily recognizable one was this symbol.

Additional information can be found at <https://thenounproject.com/ochavisual/collection/ocha-humanitarian-icons-v02/>

Notes 9-22-2022: Committee discussed if the compartments should be identified. Moved to end of Chapter 6 or until the Communications task group has a symbol suggestion, whichever comes first.

**Committee Action:** Disapprove 20-2-2

**REPORT OF HEARING:**

**Modification (if any):**

**Committee Reason:** The committee felt the choice of symbol was not appropriate, and there was no agreement for any other alternatives shown during the discussion. There were also the same concerns for this being a space designation and having to comply with the signage requirements or raised, braille and placement. This compartment also has a door wider than typical compartments and swings out instead of in, so you should be able to identify this compartment without signage.

**604.10.5-BOECKER.doc**

<b>Report for 06-30- 2021</b>		
<b>Committee decision: D</b>	<b>Committee Vote at Meeting: 20-2-2</b>	<b>Committee Vote on Ballot:</b>
<b>REPORT OF HEARING:</b>		
Modification (if any):		
Committee Reason: The committee felt the choice of symbol was not appropriate, and there was no agreement for any other alternatives shown during the discussion. There were also the same concerns for this being a space designation and having to comply with the signage requirements or raised, braille and placement. This compartment also has a door wider than typical compartments and swings out instead of in, so you should be able to identify this compartment without signage.		
<b>PUBLIC COMMENT- FIRST DRAFT:</b>		
Proponent:		
Desired Action:		
Modification:		
Reason:		
<b>Committee decision: AS/AM/D</b>	<b>Committee Vote at Meeting:</b>	<b>Committee Vote on Ballot:</b>
<b>REPORT OF HEARING – FIRST DRAFT</b>		
Modification (if any):		
Committee Reason:		
<b>PUBLIC COMMENT- SECOND DRAFT:</b>		
Proponent:		
Desired Action:		
Modification:		
Reason:		
<b>Committee decision: AS/AM/D</b>	<b>Committee Vote at Meeting:</b>	<b>Committee Vote on Ballot:</b>
<b>FINAL ACTION:</b>		
Modification (if any):		
Committee Reason:		

## 06-31 – 2021

### 604.10.5(New)

**Proponent:** Sharon Toji, Access Communications

#### SECTION 604 WATER CLOSETS AND TOILET COMPARTMENTS

**Add new text as follows:**

#### **604.10 Ambulatory accessible toilet compartments.**

**604.10.5 Signs.** Ambulatory accessible toilet compartment shall be identified with a visual sign stating “Ambulatory Stall”. Where a toilet room does not contain an accessible stall, but does include an ambulatory stall, a visual sign shall be located on or adjacent to the toilet room door stating “Ambulatory stall inside.”

---

**REASON:** People who need ambulatory stalls often have difficulty walking, but if an interior restroom or an unattached restroom building on a large campus cannot be made fully accessible but can have a stall remodeled to conform to standards for ambulatory use, there are not only no markings to inform those who need the stall that it is available, but they may see a sign outside stating the restroom is not accessible, and be directed a significant distance away to another restroom. Although an ambulatory accessible compartment is outwardly slightly distinctive in that it is more narrow than a regular inaccessible stall, nevertheless in a large restroom it may not stand out enough to be identified by someone who needs it. A visual sign on the door would solve that problem with a very small expense.

We have developed a pictogram for an ambulatory accessible compartment (see Fig. A) which would provide additional assistance, but at a minimum, visual text would be helpful.



Fig. A - Ambulatory Pictogram

Notes 9-22-2022: Committee discussed if the compartments should be identified. Moved to end of Chapter 6 or until the Communications task group has a symbol suggestion, whichever comes first.

**Committee Action: WITHDRAWN BY PROPONENT**

**REPORT OF HEARING:**

**Modification (if any):**

**Committee Reason:**

604.10.5-TOJI.doc

<b>Report for 06-31- 2021</b>		
<i>Committee decision: Withdrawn</i>	<i>Committee Vote at Meeting:</i>	<i>Committee Vote on Ballot:</i>
<b>REPORT OF HEARING:</b>		
Modification (if any):		
Committee Reason:		
<b>PUBLIC COMMENT- FIRST DRAFT:</b>		
Proponent:		
Desired Action:		
Modification:		
Reason:		
<i>Committee decision: AS/AM/D</i>	<i>Committee Vote at Meeting:</i>	<i>Committee Vote on Ballot:</i>
<b>REPORT OF HEARING – FIRST DRAFT</b>		
Modification (if any):		
Committee Reason:		
<b>PUBLIC COMMENT- SECOND DRAFT:</b>		
Proponent:		
Desired Action:		
Modification:		
Reason:		
<i>Committee decision: AS/AM/D</i>	<i>Committee Vote at Meeting:</i>	<i>Committee Vote on Ballot:</i>
<b>FINAL ACTION:</b>		
Modification (if any):		
Committee Reason:		

**06-32 – 2021**  
**605.3**

**Proponent:** Richard Williams, CWA Consultants representing self

**Revise as follows:**

**SECTION 605**  
**URINALS**

**605.3 Clear Floor Space.** A clear floor space complying with Section 305.3, positioned for forward approach, shall be provided. Where the depth of the forward approach to the urinal exceeds 24 inches (610 mm), the width of the clear floor space shall be a minimum 36 inches (914 mm) and shall comply with Section 305.7.2.

---

**REASON:** The proposed change to Section 605.3 is an attempt to clarify the requirement for additional clear floor space with for urinals when the depth of surrounding walls or partitions exceeds 24". This proposal does not change the requirement but as is currently written, we find this increased width requirement is often overlooked by designers. Adding the reference to Section 305.7.2 will help to clarify this requirement.

**Committee Action:** 14-10-2 As Submitted

**REPORT OF HEARING:**

**Modification (if any):**

**Committee Reason:** While the committee felt that it is important to remind designers that a urinal might be in an alcove and then the approach would be wider, the text should not repeat the requirements in the alcove building block in Section 305.7.2. Public comments are expected to address this.

605.3\_Williams.doc

<b>Report for 06-32– 2021</b>		
<i>Committee decision: AS</i>	<i>Committee Vote at Meeting: 14-10-2</i>	<i>Committee Vote on Ballot:</i>
<b>REPORT OF HEARING:</b>		
Modification (if any):		
Committee Reason: While the committee felt that it is important to remind designers that a urinal might be in an alcove and then the approach would be wider, the text should not repeat the requirements in the alcove building block in Section 305.7.2. Public comments are expected to address this.		
<b>PUBLIC COMMENT- FIRST DRAFT:</b>		
Proponent:		
Desired Action:		
Modification:		
Reason:		
<i>Committee decision: AS/AM/D</i>	<i>Committee Vote at Meeting:</i>	<i>Committee Vote on Ballot:</i>
<b>REPORT OF HEARING – FIRST DRAFT</b>		
Modification (if any):		
Committee Reason:		
<b>PUBLIC COMMENT- SECOND DRAFT:</b>		

<b>Report for 06-32– 2021</b>		
Proponent:		
Desired Action:		
Modification:		
Reason:		
<b>Committee decision: AS/AM/D</b>	<b>Committee Vote at Meeting:</b>	<b>Committee Vote on Ballot:</b>
<b>FINAL ACTION:</b>		
Modification (if any):		
Committee Reason:		



## **06-33 – 2021**

**605.5(New), 605.5.1(New), 605.5.2(New), 605.5.3(New)**

**Proponent:** Kimberly Paarlberg, International Code Council

**Add new text as follows:**

### **SECTION 605 URINALS**

**605.5 Urinal compartments.** Urinal compartments, where provided shall comply with Section 605.5.

**605.5.1 Size.** The minimum area of a urinal compartment shall be 60 inches (1525 mm) minimum in depth and a width of 35 inches (890 mm) minimum and 37 inches (940 mm) maximum.

**605.5.2 Doors.** Doors for urinal compartments shall comply with Sections 404.2.2, 404.2.3.2, 404.2.4 and 404.2.9. The door shall be self-closing with a balanced door or spring hinges. Door hardware shall comply with Section 404.2.6. In addition a door pull complying with Section 404.2.6 shall be placed on both sides of the door near the latch. Compartment doors shall not swing into the required minimum area of the compartment.

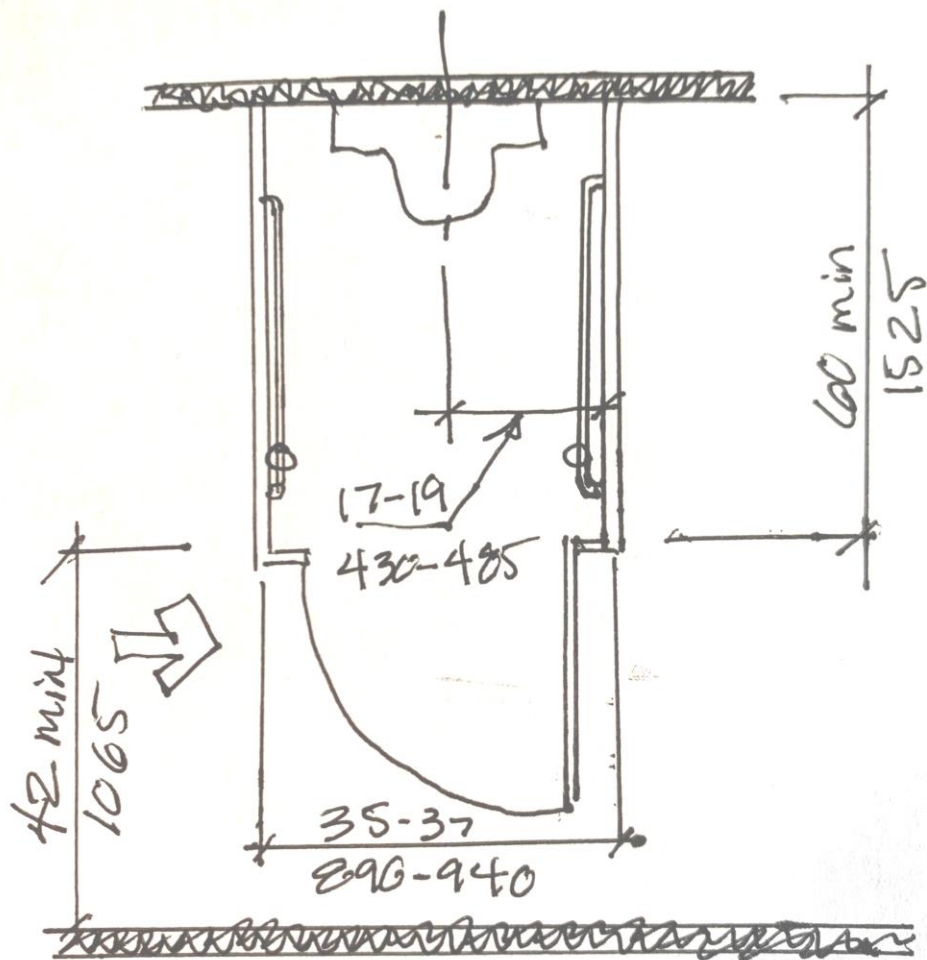
**Exceptions:**

1. Outside of the urinal compartment, the door shall not be required to comply with Section 404.2.3.2 where the approach is to the latch side of the compartment door, clearance between the door side of the compartment and any obstruction is 42 inches (1065 mm) minimum. Hinge and latch side of the doors are permitted to be oriented so that the door opens in the direction of the approach.
2. Within the ambulatory accessible toilet compartment, maneuvering clearances at the door shall not be required to comply with Section 404.2.3.2.

**605.5.3 Grab bars.** Grab bars shall comply with Section 609. Horizontal side wall grab bars complying with Section 604.5.1.1 shall be provided on both sides of the compartment.

---

**REASON:** The 2021 IPC and IBC allows gender neutral multi-stall toilet rooms. For privacy, this may result in the required accessible urinal being located in a compartment. It is my understanding that persons choosing to use the urinal instead of transferring to the water closet will have some weight bearing ability, therefore, this proposal is based on an ambulatory stall requirement.



2021 IPC

**SECTION 403  
MINIMUM PLUMBING FACILITIES**

403.1.1 Fixture calculations. To determine the occupant load of each sex, the total occupant load shall be divided in half. To determine the required number of fixtures, the fixture ratio or ratios for each fixture type shall be applied to the occupant load of each sex in accordance with Table 403.1. Fractional numbers resulting from applying the fixture ratios of Table 403.1 shall be rounded up to the next whole number. For calculations involving multiple occupancies, such fractional numbers for each occupancy shall first be summed and then rounded up to the next whole number.

**Exceptions:**

1. The total occupant load shall not be required to be divided in half where *approved* statistical data indicate a distribution of the sexes of other than 50 percent of each sex.
2. Where multiple-user facilities are designed to serve all genders, the minimum fixture count shall be calculated 100 percent, based on total occupant load. In such multiple-user facilities, each fixture type shall be in accordance with ICC A117.1 and each urinal that is provided shall be located in a stall.
3. Distribution of the sexes is not required where single-user water closets and bathing room fixtures are provided in accordance with Section 403.1.2.

403.2 Separate facilities. Where plumbing fixtures are required, separate facilities shall be provided for each sex.

**Exceptions:**

1. Separate facilities shall not be required for dwelling units and sleeping units.
2. Separate facilities shall not be required in structures or tenant spaces with a total occupant load, including both employees and customers, of 15 or fewer.
3. Separate facilities shall not be required in mercantile occupancies in which the maximum occupant load is 100 or fewer.
4. Separate facilities shall not be required in business *occupancies* in which the maximum occupant load is 25 or fewer.
5. Separate facilities shall not be required to be designated by sex where single-user toilet rooms are provided in accordance with Section 403.1.2.
6. Separate facilities shall not be required where rooms having both water closets and lavatory fixtures are designed for use by both sexes and privacy for water closets is provided in accordance with Section 405.3.4. Urinals shall be located in an area visually separated from the remainder of the facility or each urinal that is provided shall be located in a stall.

**Committee Action:** 19-2-3 Disapproved

**REPORT OF HEARING:**

**Modification (if any):**

**Committee Reason:** The committee felt that additional information on the use of urinals by persons with disabilities is needed to determine if an ambulatory type compartment or a wheelchair accessible type compartment is needed. With the more common design of multi-gender toilet room this is a gap in the current standard.

605 NEW-PAARLBERG.doc

<b>Report for 06-33- 2021</b>		
<b>Committee decision:</b> D	<b>Committee Vote at Meeting:</b> 19-2-3	<b>Committee Vote on Ballot:</b>
<b>REPORT OF HEARING:</b>		
Modification (if any):		
Committee Reason: The committee felt that additional information on the use of urinals by persons with disabilities is needed to determine if an ambulatory type compartment or a wheelchair accessible type compartment is needed. With the more common design of multi-gender toilet		

<b>Report for 06-33- 2021</b>		
room this is a gap in the current standard.		
<b>PUBLIC COMMENT- FIRST DRAFT:</b>		
Proponent:		
Desired Action:		
Modification:		
Reason:		
<b>Committee decision: AS/AM/D</b>	<b>Committee Vote at Meeting:</b>	<b>Committee Vote on Ballot:</b>
<b>REPORT OF HEARING – FIRST DRAFT</b>		
Modification (if any):		
Committee Reason:		
<b>PUBLIC COMMENT- SECOND DRAFT:</b>		
Proponent:		
Desired Action:		
Modification:		
Reason:		
<b>Committee decision: AS/AM/D</b>	<b>Committee Vote at Meeting:</b>	<b>Committee Vote on Ballot:</b>
<b>FINAL ACTION:</b>		
Modification (if any):		
Committee Reason:		

## **06-34 – 2021**

### **605.3, 605.4**

**Proponent:** Gene Boecker, Code Consultants, Inc.

**Revise as follows:**

#### **SECTION 605**

#### **URINALS**

**605.3 Clear floor space.** A clear floor space positioned for forward approach shall be provided measured from front, exterior the rim of the urinal.

**605.4 Flush controls.** Flush controls shall be hand operated or automatic. Hand operated flush controls shall comply with Section 309.

**Exception:** The clear floor space shall not be required to extend under the urinal for the purposes of Section 308.2 where the controls have a high reach of 44 inches (1120 mm) maximum.

---

**REASON:** These two proposals seek to address commonly understood but not written ways that the provisions are interpreted. First, due to the height and configuration of the urinal, a clear floor space cannot be provided under the urinal so the measurement must begin at the front rim of the fixtures. However, this creates a problem for proper application of the flush control section. Now that we clearly state in 308.2.2 that the “knee and toe clearance complying with Section 306 shall extend beneath the element for a distance not less than the required reach depth over the obstruction” the text effectively prohibits a flush control that does not project at least as far from the wall as the rim of the urinal. This type of configuration has never been applied and would interfere with the effective use of the urinal.

The exception recognizes the fact that the reach must by necessity be further than the obstruction and reinserts the 44-inch height that was in earlier editions of the A117.1 and ADAAG. It is also consistent with the height noted in the California Building Code’s amended text for urinal flush control height. Together, these two provisions put in writing the manner in which these provisions have been interpreted.

---

## **06-34 – 2021 modification**

### **605.3, 605.4**

**Proponent:** Gene Boecker, Code Consultants, Inc.

**Further revise as follows:**

#### **SECTION 605**

#### **URINALS**

**605.3 Clear floor space.** A clear floor space complying with Section 305 positioned for forward approach shall be provided measured from the front, exterior the rim of the urinal.

**605.4 Flush controls.** Flush controls shall be hand operated or automatic. Hand operated flush controls shall comply with Section 309.

**Exception:** The clear floor space shall not be required to extend under the urinal for the purposes of Section 308.2 where the controls have a high reach of 44 inches (1120 mm) maximum.

---

Reason:

There are two modifications. The first is to make it clear that the clear floor space must comply with all the provisions of Section 305, including any alcove conditions. By referring to Section 305, not only the floor space dimensions but all parts of 305 come into play. This is often considered intuitive, but the added language will make it clear to the novice standard user. The second modification is essentially editorial.

**Committee Action:** AM 26-3-1

**REPORT OF HEARING:**

**Modification (if any):**

**Further modify as follows:**

**SECTION 605  
URINALS**

**605.3 Clear floor space.** A clear floor space complying with Section 305 positioned for forward approach shall be provided measured from the front, exterior ~~the~~ of the urinal rim ~~of the urinal.~~

**605.4 Flush controls.** Flush controls shall be hand operated or automatic. Hand operated flush controls shall comply with Section 309.

**Exception:** The clear floor space shall not be required to extend under the urinal for the purposes of Section 308.2 where the controls have a high reach of 44 inches (1120 mm) maximum.

**Committee Reason:** The modification to add a reference to Section 305 in Section 605.3 emphasizes that a urinal may be in an alcove due to walls, partitions or privacy screens. Thus the space between the partitions may need to be 36” instead of 30”. The proposal provides direction for where to measure the clear floor space at the urinal. It needs to be in front of the urinal, since the person stands to use the urinal. Section 605.4 would require the clear floor space under the urinal for access to controls. Per the exception, assuming the clear floor space is now in front of the urinal, the access to the controls could meet the criteria for obstructed forward reach.

**605.3\_605.4-BOECKER.doc**

**Report for 06-34- 2021**

<b>Committee decision: AM</b>	<b>Committee Vote at Meeting: 26-3-1</b>	<b>Committee Vote on Ballot:</b>
<b>REPORT OF HEARING:</b>		
Modification (if any):		
<b>SECTION 605 URINALS</b>		
<b>605.3 Clear floor space.</b> A clear floor space <u>complying with Section 305</u> positioned for forward approach shall be provided measured from <u>the front, exterior the of the urinal rim of the urinal.</u>		
<b>605.4 Flush controls.</b> Flush controls shall be hand operated or automatic. Hand operated flush controls shall comply with Section 309. <b>Exception:</b> The clear floor space shall not be required to extend under the urinal for the purposes of Section 308.2 where the controls have a high reach of 44 inches (1120 mm) maximum.		
Committee Reason: The modification to add a reference to Section 305 in Section 605.3 emphasizes that a urinal may be in an alcove due to walls, partitions or privacy screens. Thus the space between the partitions may need to be 36" instead of 30". The proposal provides direction for where to measure the clear floor space at the urinal. It needs to be in front of the urinal, since the person stands to use the urinal. Section 605.4 would require the clear floor space under the urinal for access to controls. Per the exception, assuming the clear floor space is now in front of the urinal, the access to the controls could meet the criteria for obstructed forward reach.		
<b>PUBLIC COMMENT- FIRST DRAFT:</b>		
Proponent:		
Desired Action:		
Modification:		
Reason:		
<b>Committee decision: AS/AM/D</b>	<b>Committee Vote at Meeting:</b>	<b>Committee Vote on Ballot:</b>
<b>REPORT OF HEARING – FIRST DRAFT</b>		
Modification (if any):		
Committee Reason:		
<b>PUBLIC COMMENT- SECOND DRAFT:</b>		
Proponent:		
Desired Action:		
Modification:		
Reason:		
<b>Committee decision: AS/AM/D</b>	<b>Committee Vote at Meeting:</b>	<b>Committee Vote on Ballot:</b>
<b>FINAL ACTION:</b>		
Modification (if any):		
Committee Reason:		



# 06-35 – 2021

## 606.2

**Proponent:** Kimberly Paarlberg, International Code Council

**Revise as follows:**

### SECTION 606 LAVATORIES AND SINKS

**606.2 Clear floor space.** A clear floor space complying with Section 305.3, positioned for forward approach, shall be provided. Knee and toe clearance complying with Section 306 shall be provided. The dip of the overflow shall not be considered in determining knee and toe clearances.

**Exceptions:**

1. A clear floor space providing a parallel approach shall be permitted at a kitchen sink in a space where a cook top or conventional range is not provided.
2. For other than sinks in kitchens, where a sink requires a deep basin to perform its intended purpose or requires a specialized drain that cannot be located outside of the knee space, a parallel approach shall be permitted to be located adjacent to the sink.
- 2.3 The requirement for knee and toe clearance shall not apply to a lavatory in a toilet or bathing facility for a single occupant, accessed only through a private office and not for common use or public use.
- 3.4 A knee clearance of 24 inches (610 mm) minimum above the floor shall be permitted at lavatories and sinks used primarily by children ages 6 through 12 where the higher of the rim or counter surface is 31 inches (785 mm) maximum above the floor.
- 4.5 A clear floor space providing a parallel approach shall be permitted at lavatories and sinks used primarily by children ages 5 and younger.
- 5.6 The requirement for knee and toe clearance shall not apply to more than one bowl of a multibowl sink.
- 6.7 A clear floor space providing a parallel approach shall be permitted at wet bars.

---

**REASON:** This was proposed to the I-codes in E143-21. An added exception is provided that allows a parallel approach to the sink where the sink must be of a kind that a forward approach is not possible. This happens at medical scrub sinks, art sinks, laboratory sinks and similar sinks where caustic or extremely hot liquids may be poured and the sink is of a depth to minimize the potential that these dangerous liquids could splash out and adversely affect the surrounding materials or people. In certain instances, the drain configuration itself, in order to provide this protection, is designed such that adequate knee space is not possible for a forward approach. In these cases, although access is not possible for a forward approach, a parallel approach would still be acceptable, in order to limit the hazard to an individual using a mobility device and yet afford access. In work environments, this can be addressed through reasonable accommodations. However, teaching facilities such as high school art rooms, college labs, teaching hospitals and

similar facilities require accessibility since the student station is not an employee workstation. This addresses the issue directly without the need to seek a waiver or code modification. Access to the faucet and any other controls would still be required and would still need to be addressed in the design. It provided access but recognizes that different types of sinks may require different solutions for that access.



**Committee Action:** AS 28-0-2

**REPORT OF HEARING:**

**Modification (if any):**

**Committee Reason:** The proposal provides clarification for sinks that need a deep bowl and may or may not be considered a ‘service sink’ (which are exempted). The sink will be able to used as intended and a person would have side approach for access. This is a reasonable compromise.

**606.2-PAARLBERG.doc**

<b>Report for 06-35- 2021</b>		
<b>Committee decision:</b> AS	<b>Committee Vote at Meeting:</b> 28-0-2	<b>Committee Vote on Ballot:</b>
<b>REPORT OF HEARING:</b>		
Modification (if any):		
Committee Reason: The proposal provides clarification for sinks that need a deep bowl and may or may not be considered a ‘service sink’ (which are exempted). The sink will be able to used as intended and a person would have side approach for access. This is a reasonable compromise.		
<b>PUBLIC COMMENT- FIRST DRAFT:</b>		
Proponent:		

<b>Report for 06-35- 2021</b>		
Desired Action:		
Modification:		
Reason:		
<b>Committee decision: AS/AM/D</b>	<b>Committee Vote at Meeting:</b>	<b>Committee Vote on Ballot:</b>
<b>REPORT OF HEARING – FIRST DRAFT</b>		
Modification (if any):		
Committee Reason:		
<b>PUBLIC COMMENT- SECOND DRAFT:</b>		
Proponent:		
Desired Action:		
Modification:		
Reason:		
<b>Committee decision: AS/AM/D</b>	<b>Committee Vote at Meeting:</b>	<b>Committee Vote on Ballot:</b>
<b>FINAL ACTION:</b>		
Modification (if any):		
Committee Reason:		

## 06-36 – 2021

### 606.2

**Proponent:** Richard Williams, CWA Consultants representing self

**Revise as follows:**

#### SECTION 606 LAVATORIES AND SINKS

**606.2 Clear floor space.** A clear floor space complying with Section 305.3, positioned for forward approach, shall be provided. Cabinetry or doors that open and retract into surrounding cabinetry are not permitted. Knee and toe clearance complying with Section 306 shall be provided. The dip of the overflow shall not be considered in determining knee and toe clearances.

**Exceptions:**

1. A clear floor space providing a parallel approach shall be permitted at a kitchen sink in a space where a cook top or conventional range is not provided.
2. The requirement for knee and toe clearance shall not apply to a lavatory in a toilet or bathing facility for a single occupant, accessed only through a private office and not for common use or public use.
3. A knee clearance of 24 inches (610 mm) minimum above the floor shall be permitted at lavatories and sinks used primarily by children ages 6 through 12 where the higher of the rim or counter surface is 31 inches (785 mm) maximum above the floor.
4. A clear floor space providing a parallel approach shall be permitted at lavatories and sinks used primarily by children ages 5 and younger.
5. The requirement for knee and toe clearance shall not apply to more than one bowl of a multibowl sink.
6. A clear floor space providing a parallel approach shall be permitted at wet bars.
7. Cabinetry that can be removed without removal or replacement of the lavatory is permitted in Type A and Type B units and shall comply with Sections 1103 and 1104 respectively.

---

**REASON:** This is the first of two proposals recommending a change to Section 606.2. This clarifies the requirement for forward approach under lavatories and sinks to be clear and unobstructed. We also added an exception to clarify that cabinetry that can be removed is permitted in Type A and Type B units.

At least a couple of occasions per year we will receive plans where the designer proposes cabinets under a lavatory or sink where forward approach is required (for example, in kitchens with cooking appliances in common use areas). It is our opinion that this is not permitted per A117.1 since Section 305.6 requires the following: One full, unobstructed side of a clear floor space shall adjoin or overlap an accessible route or adjoin another clear floor space.

The addition of cabinet doors, even if they can be opened and then pushed into the cabinet to provide the required clear width, would require an additional step for someone who needs forward approach to a sink or lavatory, and we do not feel this is in keeping with the requirements of 305.6.

**Committee Action:** D 31-0-2

**REPORT OF HEARING:**

**Modification (if any):**

**Committee Reason:** The proposal was disapproved because the committee preferred the options in Proposal 06-37-2021.

**606.2-1\_Williams.doc**

<b>Report for 06-36- 2021</b>		
<b>Committee decision:</b> D	<b>Committee Vote at Meeting:</b> 31-0-2	<b>Committee Vote on Ballot:</b>
<b>REPORT OF HEARING:</b>		
Modification (if any):		
Committee Reason: The proposal was disapproved because the committee preferred the options in Proposal 06-37-2021.		
<b>PUBLIC COMMENT- FIRST DRAFT:</b>		
Proponent:		
Desired Action:		
Modification:		
Reason:		
<b>Committee decision:</b> AS/AM/D	<b>Committee Vote at Meeting:</b>	<b>Committee Vote on Ballot:</b>
<b>REPORT OF HEARING – FIRST DRAFT</b>		
Modification (if any):		
Committee Reason:		
<b>PUBLIC COMMENT- SECOND DRAFT:</b>		
Proponent:		
Desired Action:		
Modification:		
Reason:		
<b>Committee decision:</b> AS/AM/D	<b>Committee Vote at Meeting:</b>	<b>Committee Vote on Ballot:</b>
<b>FINAL ACTION:</b>		
Modification (if any):		
Committee Reason:		

## 06-37 – 2021

### 606.2

**Proponent:** Richard Williams, CWA Consultants representing self

**Revise as follows:**

#### SECTION 606 LAVATORIES AND SINKS

**606.2 Clear floor space.** A clear floor space complying with Section 305.3, positioned for forward approach, shall be provided. Knee and toe clearance complying with Section 306 shall be provided. The dip of the overflow shall not be considered in determining knee and toe clearances.

**Exceptions:**

1. A clear floor space providing a parallel approach shall be permitted at a kitchen sink in a space where a cook top or conventional range is not provided.
2. The requirement for knee and toe clearance shall not apply to a lavatory in a toilet or bathing facility for a single occupant, accessed only through a private office and not for common use or public use.
3. A knee clearance of 24 inches (610 mm) minimum above the floor shall be permitted at lavatories and sinks used primarily by children ages 6 through 12 where the higher of the rim or counter surface is 31 inches (785 mm) maximum above the floor.
4. A clear floor space providing a parallel approach shall be permitted at lavatories and sinks used primarily by children ages 5 and younger.
5. The requirement for knee and toe clearance shall not apply to more than one bowl of a multibowl sink.
6. A clear floor space providing a parallel approach shall be permitted at wet bars.
7. Doors that open and retract into surrounding cabinetry are permitted, provided all requirements are met for clear floor space and knee and toe clearance.
8. Cabinetry that can be removed without removal or replacement of the lavatory is permitted in Type A and Type B units and shall comply with Sections 1103 and 1104 respectively.

---

**REASON:** This is the second of two proposals recommending a change to Section 606.2. Our first proposal seeks to clarify that an open space under a lavatory or sink (no cabinets or cabinet doors) is to be provided when forward approach is required. In other words, cabinetry or doors that open and retract into surrounding cabinetry are NOT permitted. This proposal adds language that **ALLOWS** for cabinet doors that can be pushed into the cabinet to provide the required forward approach. We also added an exception to clarify that cabinetry that can be removed is permitted in Type A and Type B units.

We are submitting two contradictory proposals in the hopes that the committee will clarify which of these two approaches are actually recognized by the ADA community. We would find either approach acceptable, but we feel that the important part is to specify the correct interpretation, and the best way to do this is by modification of Section 606.2.

**Committee Action:** AM 28-1-4

Notes:

Mod submitted by proponent was original motion for AM – “Within dwelling units” and “where doors are full retracted” added to Exception 7

Mod to delete Exception 8 – 27-1-4

Mod to add “and sleeping units” to Exception 7 - 31-0-3

**REPORT OF HEARING:**

**Modification (if any):**

**Further revise as follows:**

**606.2 Clear floor space. ...**

7. Within dwelling units and sleeping units, Doors that open and retract into surrounding cabinetry are permitted, provided all requirements are met for clear floor space and knee and toe clearance where doors are fully retracted.
8. ~~Cabinetry that can be removed without removal or replacement of the lavatory is permitted in Type A and Type B units and shall comply with Sections 1103 and 1104 respectively.~~

**Committee Reason:** The modification to delete Exception 8 was because the exceptions specific to Type A and Type B dwelling units are in Section 1103 and 1104, so this is redundant and not needed. In addition, the reference is too broad and the terminology is not the same as in 1103.11.2.2, 1103.12.3.1, 1104.11.3.1.1 and 1104.12.2.1, do this could be confusing.

The modification to Exception 7 was to limit the option for retractable cabinet fronts to dwelling units where the people would be familiar with and have control of the space. Sleeping units were also added for situations where someone wanted to provide a more accessible front approach rather than the required side approach.

Exception 7 would provide an option for cabinet fronts at front approach lavatories and sinks similar to what is common in television cabinets – and it eliminates the question about such cabinet doors obstructing other parts of the kitchen where they do not retract.

**606.2-2\_Williams.doc**

<b>Report for 06-37– 2021</b>		
<i>Committee decision: AM</i>	<i>Committee Vote at Meeting: 28-1-4</i>	<i>Committee Vote on Ballot:</i>
<b>REPORT OF HEARING:</b>		
Modification (if any):		
<b>Further revise as follows:</b>		
7. <u>Within dwelling units and sleeping units</u> , Doors that open and retract into surrounding cabinetry are permitted, provided all requirements are met for clear floor space and knee and toe clearance <u>where doors are fully retracted</u> .		
8. <del>Cabinetry that can be removed without removal or replacement of the lavatory is permitted in Type A and Type B units and shall comply with Sections 1103 and 1104 respectively.</del>		
Committee Reason: The modification to delete Exception 8 was because the exceptions specific to Type A and Type B dwelling units are in Section 1103 and 1104, so this is redundant and not needed. In addition, the reference is too broad and the terminology is not the same as in 1103.11.2.2, 1103.12.3.1, 1104.11.3.1.1 and 1104.12.2.1, do this could be confusing.		

**Report for 06-37– 2021**

The modification to Exception 7 was to limit the option for retractable cabinet fronts to dwelling units where the people would be familiar with and have control of the space. Sleeping units were also added for situations where someone wanted to provide a more accessible front approach rather than the required side approach.

Exception 7 would provide an option for cabinet fronts at front approach lavatories and sinks similar to what is common in television cabinets – and it eliminates the question about such cabinet doors obstructing other parts of the kitchen where they do not retract.

**PUBLIC COMMENT- FIRST DRAFT:**

Proponent:

Desired Action:

Modification:

Reason:

**Committee decision: AS/AM/D****Committee Vote at Meeting:****Committee Vote on Ballot:****REPORT OF HEARING – FIRST DRAFT**

Modification (if any):

Committee Reason:

**PUBLIC COMMENT- SECOND DRAFT:**

Proponent:

Desired Action:

Modification:

Reason:

**Committee decision: AS/AM/D****Committee Vote at Meeting:****Committee Vote on Ballot:****FINAL ACTION:**

Modification (if any):

Committee Reason:



## 06-38 – 2021 606.4

**Proponent:** Kyle Thompson, Plumbing Manufacturers International (PMI)

**Revise as follows:**

### SECTION 606 LAVATORIES AND SINKS

**606.4 Faucets.** Faucets shall comply with Section 309. Hand-operated metering faucets shall remain open for 10 seconds minimum.

**Exception:** Automatic faucets shall be permitted where the activation complies with Section 308.2.2 ~~not be required to comply with Section 309 provided that the reach depth to activate the faucets and the reach depth to the water flow is 11 inches (280 mm) maximum.~~

---

**REASON:** With new technology allowing automatic faucets to be activated with motion or touch, they should be allowed to comply with the same reach requirements as manual-operated faucets as required in Section 308.2.2. This proposed change does not impact the more restrictive reach range requirements in Section 606.5.

**Note:** Motion to table to end of Chapter 6 proposals

---

## 06-38 – 2021 Replacement 606.4

**Proponent:** Kyle Thompson, Plumbing Manufacturers International (PMI)

**Replace the proposal and revise as follows:**

**606.4 Faucets.** Faucets shall comply with Section 309. Hand-operated metering faucets shall remain open for 10 seconds minimum.

**Exception:** Automatic faucets shall not be required to comply with Section 309 where the location to activate the faucet and the water flow complies with Section 308.2.2 for sinks and lavatories provided with a front approach and Section 308.3.2 for sinks provided with a side approach. ~~provided that the reach depth to activate the faucets and the reach depth to the water flow is 11 inches (280 mm) maximum.~~

**Reason:** The committee was concerned that the proposed language did not address getting your hands into the water, and that the forward obstructed reach did not address the requirements for a sink that could have a side approach. This replacement proposal will address both issues.

Notes 12-1-22: Tabled till Dec. 15 meeting

---

## 06-38 – 2021 2<sup>nd</sup> Replacement

### 606.4

**Proponent:** Kyle Thompson, Plumbing Manufacturers International (PMI)

**Replace the proposal and revise as follows:**

**606.4 Faucets.** Faucets shall comply with Section 309. Hand-operated metering faucets shall remain open for 10 seconds minimum.

**Exception:** Automatic faucets shall not be required to comply with Section 309 ~~provided that the reach depth to activate the faucets and the reach depth to the water flow is 11 inches (280 mm) maximum.~~ where the faucets comply with one of the following:

1. For sinks and lavatories provided with a forward approach, the reach to activate the faucet and the reach to the water flow comply with Section 308.2.2 (obstructed forward reach).
2. For sinks and lavatories provided with a side approach, the reach to activate the faucets and the reach to the water flow comply with Section 308.3.2 (obstructed side reach).

Reason: The committee was concerned that the proposed language did not address getting your hands into the water, and that the forward obstructed reach did not address the requirements for a sink that could have a side approach. This replacement proposal will address both issues.

---

**Committee Action:** As Modified 22-1-3

### REPORT OF HEARING:

**Modification (if any):**

**Replace the proposal and revise as follows:**

**606.4 Faucets.** Faucets shall comply with Section 309. Hand-operated metering faucets shall remain open for 10 seconds minimum.

**Exception:** Automatic faucets shall not be required to comply with Section 309 ~~provided that the reach depth to activate the faucets and the reach depth to the water flow is 11 inches (280 mm) maximum.~~ where the faucets comply with one of the following:

1. For sinks and lavatories provided with a forward approach, the reach to activate the faucet and the reach to the water flow comply with Section 308.2.2 (obstructed forward reach).
2. For sinks and lavatories provided with a side approach, the reach to activate the faucets and the reach to the water flow comply with Section 308.3.2 (obstructed side reach).

**Committee Reason:** The 2<sup>nd</sup> replacement modification was approved by the committee as this revised exception clarified that rather than reach the faucet, where automatic water is used, the activation of the faucet and the water flow is what is required to be within the associated reach range. It was noted that this language will now be different from Section 606.4.1 for enhanced reach range; whereas before they were coordinated.

606.4-THOMPSON.doc

<b>Report for 06-38- 2021</b>		
<b>Committee decision: AM</b>	<b>Committee Vote at Meeting: 22-1-3</b>	<b>Committee Vote on Ballot:</b>
<b>REPORT OF HEARING:</b>		
Modification (if any):		
<b>Replace the proposal and revise as follows:</b>		
<b>606.4 Faucets.</b> Faucets shall comply with Section 309. Hand-operated metering faucets shall remain open for 10 seconds minimum.		
<b>Exception:</b> Automatic faucets shall not be required to comply with Section 309 provided that the reach depth to activate the faucets and the reach depth to the water flow is 11 inches (280 mm) maximum, where the faucets comply with one of the following:		
<ol style="list-style-type: none"> <li>1. <u>For sinks and lavatories provided with a forward approach, the reach to activate the faucet and the reach to the water flow comply with Section 308.2.2 (obstructed forward reach).</u></li> <li>2. <u>For sinks and lavatories provided with a side approach, the reach to activate the faucets and the reach to the water flow comply with Section 308.3.2 (obstructed side reach).</u></li> </ol>		
Committee Reason: The 2 <sup>nd</sup> replacement modification was approved by the committee as this revised exception clarified that rather than reach the faucet, where automatic water is used, the activation of the faucet and the water flow is what is required to be within the associated reach range. It was noted that this language will now be different from Section 606.4.1 for enhanced reach range; whereas before they were coordinated.		
<b>PUBLIC COMMENT- FIRST DRAFT:</b>		
Proponent:		
Desired Action:		
Modification:		
Reason:		
<b>Committee decision: AS/AM/D</b>	<b>Committee Vote at Meeting:</b>	<b>Committee Vote on Ballot:</b>
<b>REPORT OF HEARING – FIRST DRAFT</b>		
Modification (if any):		
Committee Reason:		
<b>PUBLIC COMMENT- SECOND DRAFT:</b>		
Proponent:		
Desired Action:		
Modification:		
Reason:		
<b>Committee decision: AS/AM/D</b>	<b>Committee Vote at Meeting:</b>	<b>Committee Vote on Ballot:</b>
<b>FINAL ACTION:</b>		
Modification (if any):		
Committee Reason:		

# 06-39 – 2021

## 606.5

**Proponent:** Kyle Thompson, Plumbing Manufacturers International (PMI)

**Revise as follows:**

### SECTION 606 LAVATORIES AND SINKS

**606.5 Lavatories with enhanced reach range.** Where enhanced reach range is required at lavatories, faucets and soap dispenser controls shall have a reach depth of 11 inches (280 mm) maximum. Water and soap ~~outlets~~ streams shall be provided with a reach depth of 11 inches (280 mm) maximum. The lavatory shall be 34 inches (865 mm) maximum above the floor, measured to the higher of the rim or counter surface.

**Exceptions:**

1. Enhanced reach range faucets shall not be required on lavatories provided with automatic faucets where the reach depth to activate the faucets and the reach depth to the water ~~outlet~~ stream is 11 inches (280 mm) maximum.
2. Enhanced reach range soap dispensers shall not be required on lavatories provided with automatic dispensers where the reach depth to activate the soap dispensers and the reach depth to the soap ~~outlet~~ stream is 11 inches (280 mm) maximum.

---

**REASON:** The user’s concern is reaching the water or soap stream and not necessarily the outlet on the faucet or soap dispenser. The proposed change clarifies the intent of the section.

**Committee Action:** D 27-1-1

**REPORT OF HEARING:**

**Modification (if any):**

**Committee Reason:** The proposal was disapproved because the direction of the stream may vary depending on how hard the water is turned on, and it is much harder to measure to a stream. The outlet provides a specific measurable point.

**606.5-THOMPSON.doc**

Report for 06-39– 2021		
Committee decision: D	Committee Vote at Meeting: 27-1-1	Committee Vote on Ballot:
REPORT OF HEARING: Modification (if any):		
Committee Reason: The proposal was disapproved because the direction of the stream may vary depending on how hard the water is turned on, and it is much harder to measure to a stream. The outlet provides a specific measurable point.		
PUBLIC COMMENT- FIRST DRAFT:		

<b>Report for 06-39– 2021</b>		
Proponent:		
Desired Action:		
Modification:		
Reason:		
<b>Committee decision: AS/AM/D</b>	<b>Committee Vote at Meeting:</b>	<b>Committee Vote on Ballot:</b>
<b>REPORT OF HEARING – FIRST DRAFT</b>		
Modification (if any):		
Committee Reason:		
<b>PUBLIC COMMENT- SECOND DRAFT:</b>		
Proponent:		
Desired Action:		
Modification:		
Reason:		
<b>Committee decision: AS/AM/D</b>	<b>Committee Vote at Meeting:</b>	<b>Committee Vote on Ballot:</b>
<b>FINAL ACTION:</b>		
Modification (if any):		
Committee Reason:		

## 06-40 – 2021

**607.2, 607.3(New), 607.5, Figures 607.2(A), 607.2(B), 607.3(New), 607.5, 1103.2.5.1(A), 1103.2.5.1(B)**

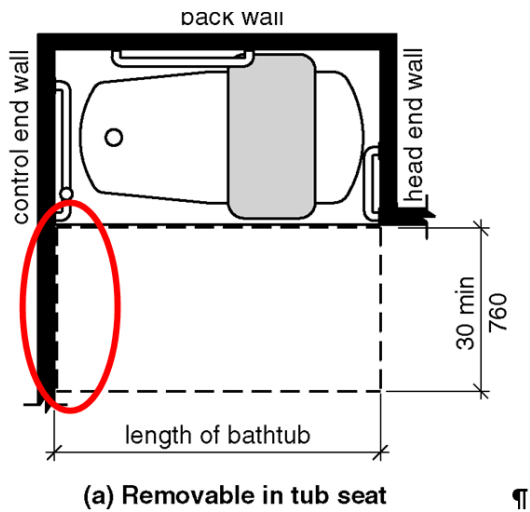
**Proponent:** Thomas Hirsch, FAIA, Hirsch Group Architecture, representing self; M. Bradley Gaskins, AIA; Gina Hillberry for United Cerebral Palsy; Joe Jurkiewicz, AIA; Marsha Mazz for United Spinal Association; Edward Steinfeld, Arch.D, AIA; and Steven R. Winkel, FAIA, PE, CASp

**Revise as follows:**

### SECTION 607 BATHTUBS

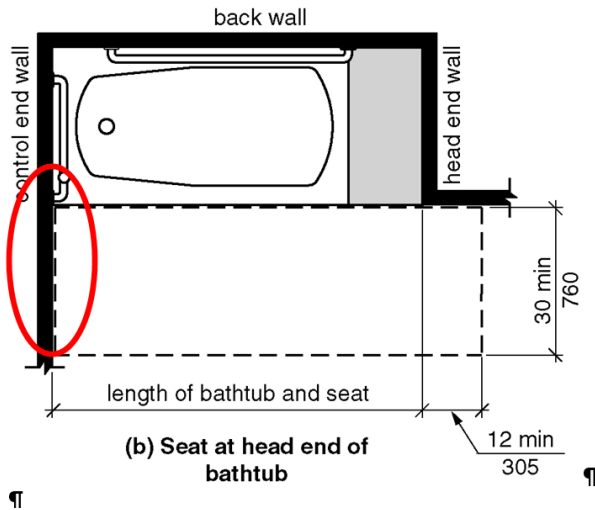
**607.2 Transfer Clearance.** A transfer clearance in front of bathtubs extending the length of the bathtub and 30 inches (760 mm) minimum in depth shall be provided. Where a permanent seat is provided at the head end of the bathtub, the transfer clearance shall extend 12 inches (305 mm) minimum beyond the wall at the head end of the bathtub.

*Note: The wall in the Figures 607.2(A) and 607.2(B) would be jogged to indicate the additional 4 inch toe clearance in the new Figure 607.3. The committee will need to decide if Figures 607.2(A) and 607.2 (B) should be revised to show the control clearance with the transfer clearance or if the control clearance should be in a separate Figure 607.3. The figure submitted indicates the transfer clearance moving forward, not an addition 4 inch control clearance as the text indicates.*



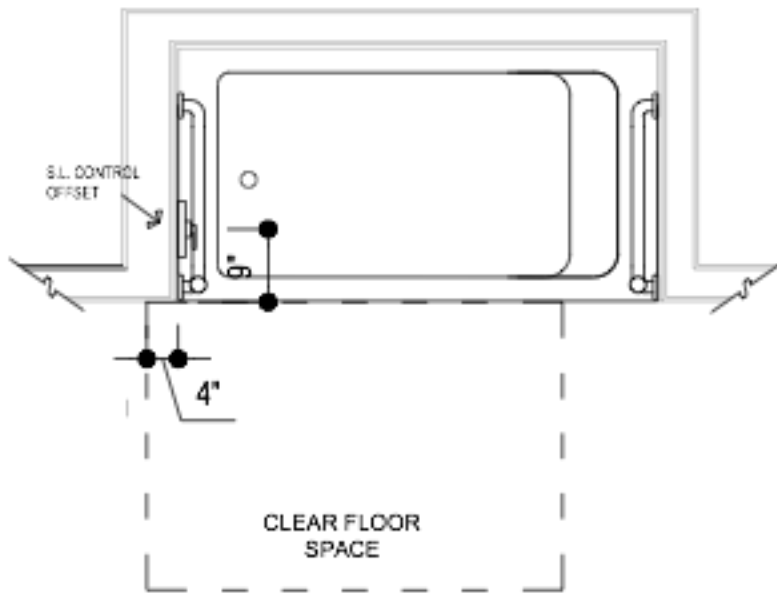
**FIGURE 607.2(A)**

**TRANSFER CLEARANCE FOR BATHTUBS WITH REMOVABLE IN TUB SEATS**



**FIGURE 607.2(B)**  
**TRANSFER CLEARANCE FOR BATHTUBS WITH SEAT AT HEAD END OF TUB**

**607.3 Control Clearance.** The clear floor space for toe clearance at the controls shall extend 4 inches (100 mm) minimum beyond the control end wall.

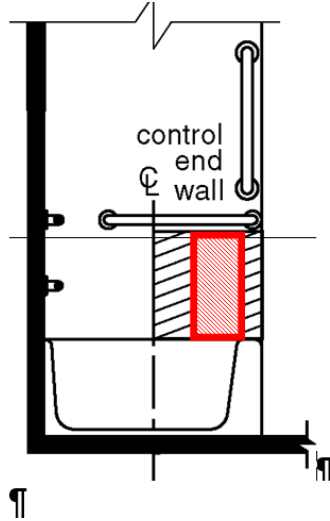


**FIGURE 607.3**  
**CLEARANCE FOR BATHTUBS CONTROLS**

**607.5 Controls.** Controls, other than drain stoppers, shall be provided on an end wall, located between the bathtub rim and grab bar, and between the open side of the bathtub and the centerline of the width of the bathtub the centerline of controls measured from the approach side

of the bathtub shall be located 5 inches (127 mm) minimum and 9 inches (229 mm) maximum from the clear floor space. Controls shall comply with Section 309.4.

*Note: The area for the controls in Figure 607.5 would be revised to the smaller area indicated in the revised text.*



**FIGURE 607.5**  
**LOCATION OF BATHTUB CONTROLS**

*Note: The references from Accessible and Type A units are shown so that the committee is clear on how this proposal will affect unit requirements.*

## **SECTION 1102** **ACCESSIBLE UNITS**

**1102.11.2 Toilet and bathing facility.** At least one toilet and bathing facility shall comply with Section 603. At least one lavatory, one water closet and either a bathtub or shower within the unit shall comply with Sections 604 through 610. These toilet and bathing fixtures shall be in a single toilet/bathing area, such that travel between fixtures does not require travel through other parts of the unit.

## **SECTION 1103** **TYPE A UNITS**

**1103.11.2.5 Bathing fixtures.** The bathing fixture shall be a bathtub complying with Section 1103.11.2.5.1 or a shower compartment complying with Section 1103.11.2.5.2.

**1103.11.2.5.1 Bathtub.** Bathtubs shall comply with Section 607.

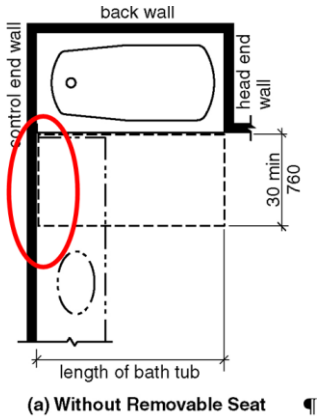
**Exception:** Countertops and cabinetry shall be permitted at one end of the clearance, provided the following criteria are met:

1. The countertop and cabinetry can be removed;
2. The floor finish extends under the countertop and cabinetry; and

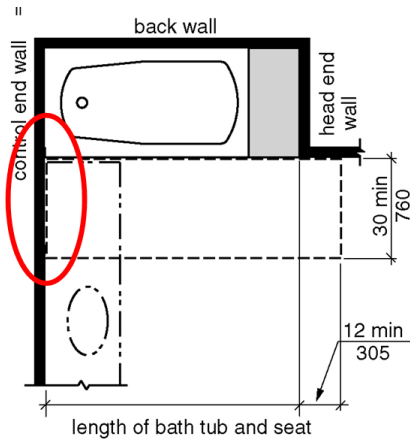


3. The walls behind and surrounding the countertop and cabinetry are finished.

*Note: The wall in the Figures 1103.11.2.5.1(A) and 1103.11.2.5.1(B) would be jogged to indicate the additional 4 inch control clearance in the new Figure 607.2.1*



**Figure 1103.11.2.5.1(A)  
CLEARANCE FOR BATHTUBS IN TYPE A UNITS WITH REMOVABLE SEATS**



**Figure 1103.11.2.5.1(B)  
CLEARANCE FOR BATHTUBS IN TYPE A UNITS WITH PERMANENT SEATS**

**REASON:** Based on anthropometry, the provision of toe space past the control end of the fixture accomplishes realistic reach of the control for 90% of persons measured. In existing buildings “technical infeasibility” provides an exception for difficult situations.

Notes: Table till end of Chapter 6

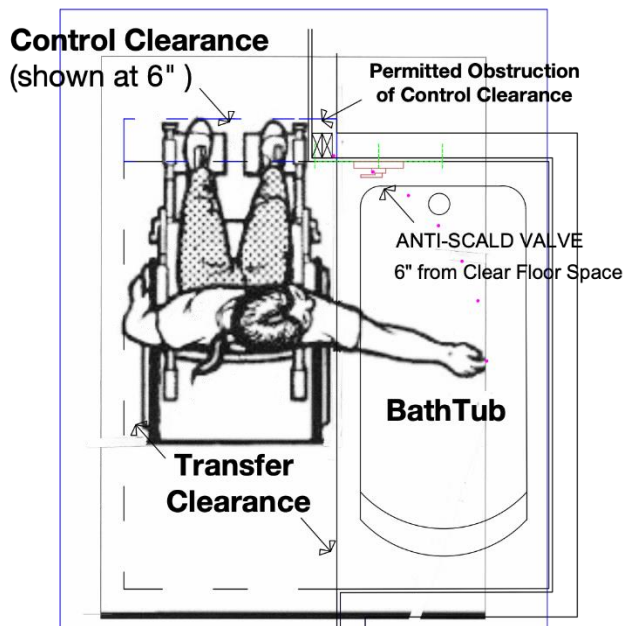
## 06-40 – 2021 Modification

607.2, 607.3(New), 607.5, Figures 607.2(A), 607.2(B), 607.3(New), 607.5, 1103.2.5.1(A), 1103.2.5.1(B)

**Proponent:** Thomas Hirsch, FAIA, Hirsch Group Architecture, representing self

**Further revise as follows:**

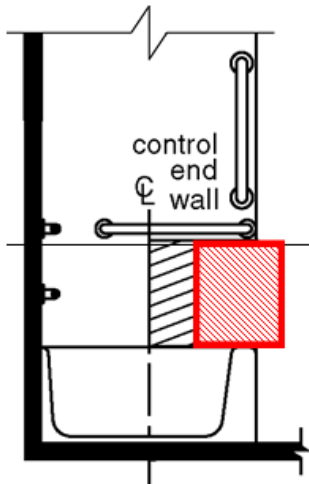
**607.3 Control Clearance.** The clear floor space for toe clearance complying with Section 306.2 at the controls shall extend 4-6 inches (100-152 mm) minimum beyond the control end wall. An obstruction by the control wall of 4 inches (102 mm) maximum shall be permitted.



*Note: This is a replacement figure. The clear floor space location was revised in the figure, but the location of the valve does not match the text in Section 607.5.*

### FIGURE 607.3 CLEARANCE FOR BATHTUBS CONTROLS

**607.5 Controls.** Controls, other than drain stoppers, located between the bathtub rim and grab bar, and the centerline of the control valve shall be located controls measured from the approach side of the bathtub shall be located 5 inches (127 mm) minimum and 9 inches (229 mm) maximum from the clear floor space. Controls shall comply with Section 309.4.



*Note: The area for the controls in Figure 607.5 would be revised to the smaller area indicated in the revised text. 9" is from the clear floor space, not from the front of the tub.*

**FIGURE 607.5  
LOCATION OF BATHTUB CONTROLS**

**Reason:**

1. Conforms “toe space” with prior use of the term in Sec. 306.2.
2. Allows intrusion of wall framing without interfering with user’s toes
3. Allows for plumbing valves & piping in typical use.

**Staff note:** This requirement would apply to Accessible and Type A units.

**Staff Note 12-1-2022:** Tabled till 12-15-2022 meeting and first in order of discussion.

**Committee Action:** As Modified

Notes 12-15-2022: Proposal split

Chair decided changes to Section 607.2 revisions are editorial

Part 1 Section 607.3 (control clearance) AM 18-7-5

Part 2 Section 607.5 (control location) AM 5-22-2; D 25-0-2

**REPORT OF HEARING:**

**Modification (if any):**

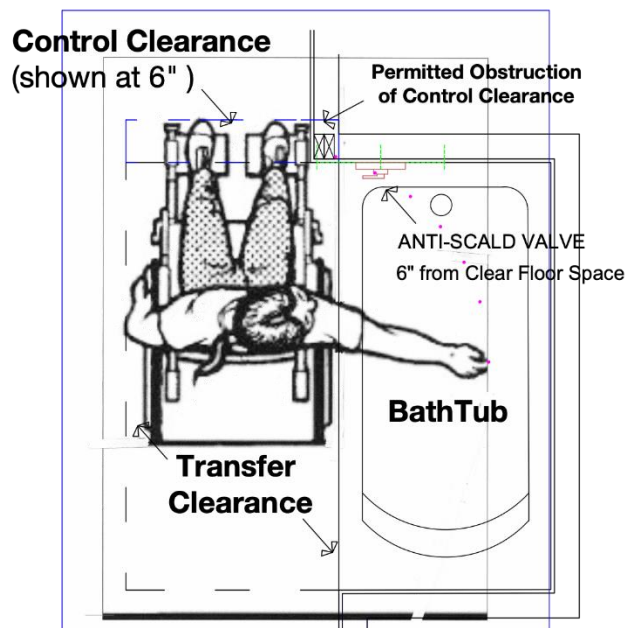
**Replace the proposal with the following:**

**607.2 Transfer Clearance.** A transfer clearance in front of bathtubs extending the length of the bathtub and 30 inches (760 mm) minimum in depth shall be provided. Where a permanent seat is provided at the head end of the bathtub, the transfer clearance shall extend 12 inches (305 mm) minimum beyond the wall at the head end of the bathtub.

**FIGURE 607.2(A)**  
**TRANSFER CLEARANCE FOR BATHTUBS WITH REMOVABLE IN TUB SEATS**

**FIGURE 607.2(B)**  
**TRANSFER CLEARANCE FOR BATHTUBS WITH SEAT AT HEAD END OF TUB**

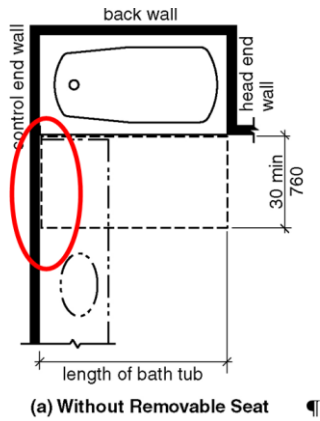
**607.3 Control Clearance.** The clear floor space for toe clearance complying with Section 306.2 at the controls shall extend 6 inches (152 mm) minimum beyond the control end wall. An obstruction by the control wall of 4 inches (102 mm) maximum shall be permitted.



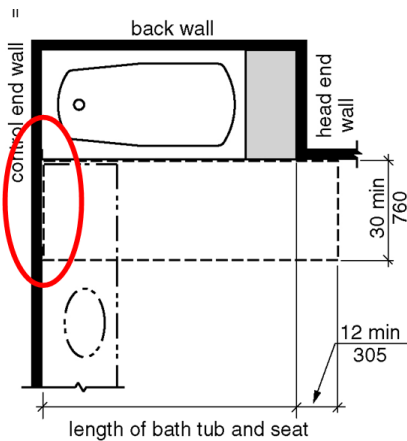
**FIGURE 607.3**  
**CLEARANCE FOR BATHTUBS CONTROLS**

*Note: The figure submitted is the suggested start for a new figure.*

*Note: The wall in the Figures 1103.11.2.5.1(A) and 1103.11.2.5.1(B) would be jogged to indicate the additional 6-inch control clearance in the new Figure 607.3*



**Figure 1103.11.2.5.1(A)**  
**CLEARANCE FOR BATHTUBS IN TYPE A UNITS WITH REMOVABLE SEATS**



**Figure 1103.11.2.5.1(B)**  
**CLEARANCE FOR BATHTUBS IN TYPE A UNITS WITH PERMANENT SEATS**

**Committee Reason:** The proposal was divided for discussion. For clarity, the modification shows the final version approved by the committee. The acting chair, Gina Hilberry, determined that the change to Section 607.2 was editorial due to the change for control clearance. The replacement for the new Section 607.3 for control clearance aligns better with the information for reach based on the anthropometric information from Dr. Steinfeld. The obstruction in the control clearance would allow for the physical elements in the wall needed to construct a corner. Since the widest part of the wheelchair is at the rear wheels, this will not be an obstruction for reach. There were concerns raised that the language was not clear and additional modifications are necessary. The committee felt that the current language in Section 607.5 for control location provided better direction since it included all of the controls (temperature, on/off, diverters) instead of just to the center of a valve. The proposed

language assumed one center control, was too restrictive, and did not address the handle locations, spread mount controls or the diverter location.

607.2-HIRSCH.doc

<b>Report for 06-40- 2021</b>		
<b>Committee decision: AM</b>	<b>Committee Vote at Meeting: 18-7-5</b>	<b>Committee Vote on Ballot:</b>
<b>REPORT OF HEARING:</b>		
Modification (if any):		
<b>Replace the proposal with the following:</b>		
<p><b>607.2 Transfer Clearance.</b> A <u>transfer</u> clearance in front of bathtubs extending the length of the bathtub and 30 inches (760 mm) minimum in depth shall be provided. Where a permanent seat is provided at the head end of the bathtub, the <u>transfer</u> clearance shall extend 12 inches (305 mm) minimum beyond the wall at the head end of the bathtub.</p>		
<b>FIGURE 607.2(A)</b>		
<b>TRANSFER CLEARANCE FOR BATHTUBS WITH REMOVABLE IN TUB SEATS</b>		
<b>FIGURE 607.2(B)</b>		
<b>TRANSFER CLEARANCE FOR BATHTUBS WITH SEAT AT HEAD END OF TUB</b>		
<p><b>607.3 Control Clearance.</b> The clear floor space for toe clearance complying with Section 306.2 at the controls shall extend 6 inches (152 mm) minimum beyond the control end wall. An obstruction by the control wall of 4 inches (102 mm) maximum shall be permitted.</p>		
<i>Note: This figure submitted is the suggested start for a new figure.</i>		
<b>FIGURE 607.3</b>		
<b>CLEARANCE FOR BATHTUBS CONTROLS</b>		
<i>Note: The wall in the Figures 1103.11.2.5.1(A) and 1103.11.2.5.1(B) would be jogged to indicate the additional 6-inch control clearance in the new Figure 607.3</i>		
<p><b>Figure 1103.11.2.5.1(A)</b> <b>CLEARANCE FOR BATHTUBS IN TYPE A UNITS WITH REMOVABLE SEATS</b></p>		
<p><b>Figure 1103.11.2.5.1(B)</b> <b>CLEARANCE FOR BATHTUBS IN TYPE A UNITS WITH PERMANENT SEATS</b></p>		
<p>Committee Reason: The proposal was divided for discussion. For clarity, the modification shows the final version approved by the committee. The acting chair, Gina Hilberry, determined that the change to Section 607.2 was editorial due to the change for control clearance. The replacement for the new Section 607.3 for control clearance aligns better with the information for reach based on the anthropometric information from Dr. Steinfeld. The obstruction in the control clearance would allow for the physical elements in the wall needed to construct a corner. Since the widest part of the wheelchair is at the rear wheels, this will not be an obstruction for reach. There were concerns raised that the language was not clear and additional modifications are necessary. The committee felt that the current language in Section 607.5 for control location provided better direction since it included all of the controls (temperature, on/off, diverters) instead of just to the center of a valve. The proposed language assumed one center control, was too restrictive, and did not address the handle locations, spread mount controls or the diverter location.</p>		
<b>PUBLIC COMMENT- FIRST DRAFT:</b>		
Proponent:		
Desired Action:		
Modification:		
Reason:		
<b>Committee decision: AS/AM/D</b>	<b>Committee Vote at Meeting:</b>	<b>Committee Vote on Ballot:</b>
<b>REPORT OF HEARING – FIRST DRAFT</b>		
Modification (if any):		
Committee Reason:		
<b>PUBLIC COMMENT- SECOND DRAFT:</b>		
Proponent:		
Desired Action:		
Modification:		
Reason:		
<b>Committee decision: AS/AM/D</b>	<b>Committee Vote at Meeting:</b>	<b>Committee Vote on Ballot:</b>
<b>FINAL ACTION:</b>		
Modification (if any):		
Committee Reason:		

## 06-41 – 2021

### 607.2, Figure 607.2(C)(New)

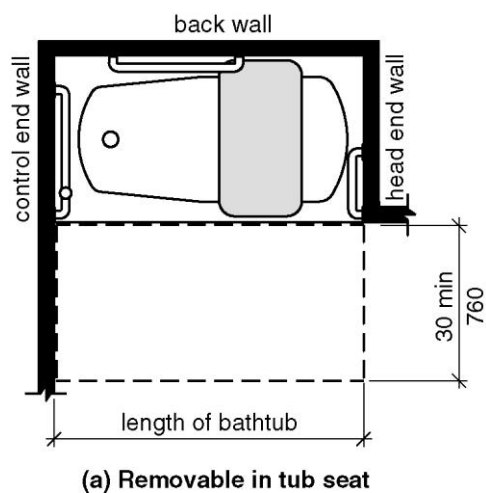
**Proponent:** Doug Anderson, representing A117.1 Accessible Bathing Task Group

**Revise as follows:**

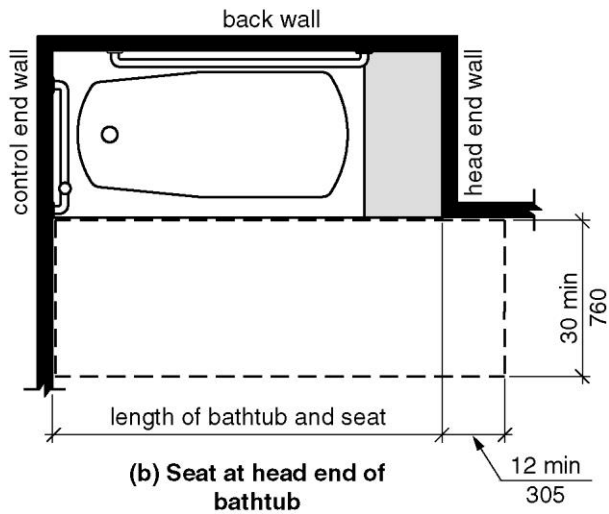
#### SECTION 607 BATHTUBS

**607.2 Clearance.** A clearance in front of bathtubs extending the length of the bathtub and 30 inches (760 mm) minimum in depth shall be provided. Where a permanent seat or fixed folding in-tub seat is provided at the head end of the bathtub, the clearance shall extend 12 inches (305 mm) minimum beyond the wall at the head end of the bathtub.

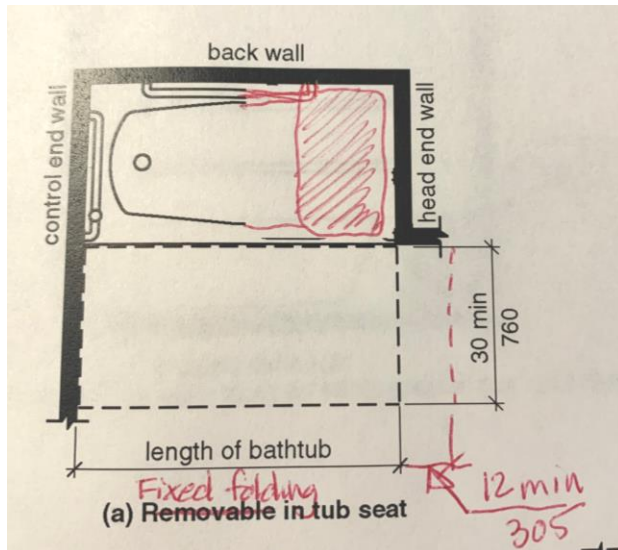
**Exception:** In an existing bathtub where the interior size of the bathroom is not enlarged and a fixed folding in-tub seat is installed, the 12 inches (305 mm) clearance beyond wall at the head end of the bathtub is not required.



**FIGURE 607.2(A)  
CLEARANCE FOR BATHTUBS WITH REMOVABLE IN TUB SEATS**



**FIGURE 607.2(B)  
CLEARANCE FOR BATHTUBS WITH SEAT AT HEAD END OF TUB**



**FIGURE 607.2(C)  
CLEARANCE FOR BATHTUBS WITH FIXED FOLDING IN-TUB SEAT AT HEAD  
END OF TUB**

**Reason:** Additional clearance would be needed when in tub seats are mounted on the headwall. The photos are to illustrate what this proposal is talking about.





**Staff Note:** This proposal is from the A117.1 Accessible Bathing Task Group. Proposals 06-41, 06-42, 06-45, 06-50 and 06-81 are all related to bathtubs with a fixed folding in-tub seat.

## **06-41 – 2021 Replacement**

**Figure 607.2(A), 607.4.2, , Figure 607.4.2(A), Figure 607.4.2(B), 610.2, Figure 610.2(A), Figure 610.2(B), 610.2.1(New), 610.2.2(New)**

**Proponent:** Doug Anderson, representing A117.1 Accessible Bathing Task Group

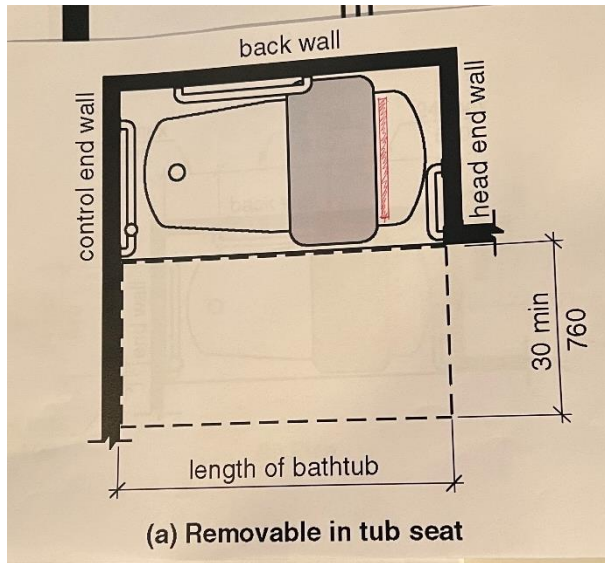
Note: Proposals 06-41, 06-42, 06-45, 06-50 and 06-81 are all related to bathtubs. Modifications to 06-41, 06-42 and 06-45 will replace the 5 proposal (separated by section) with 3 proposals (separated to one for each type of bathtub seat configuration).

**Replace with the following:**

### **SECTION 607 BATHTUBS**

**607.1 General.** Bathtubs shall comply with Section 607.

**607.2 Clearance.** A clearance in front of bathtubs extending the length of the bathtub and 30 inches (760 mm) minimum in depth shall be provided. Where a permanent seat is provided at the head end of the bathtub, the clearance shall extend 12 inches (305 mm) minimum beyond the wall at the head end of the bathtub.



**FIGURE 607.2(A)**  
**CLEARANCE FOR BATHTUBS WITH REMOVABLE IN-TUB SEATS**

*Note – seat would have to move forward in graphic*

**FIGURE 607.2(B)**  
**CLEARANCE FOR BATHTUBS WITH SEAT AT HEAD END OF TUB**

**607.3 Seat.** A permanent seat at the head end of the bathtub or a removable in-tub seat shall be provided. Seats shall comply with Section 610.

**607.4 Grab bars.** Grab bars shall comply with Section 609 and shall be provided in accordance with Section 607.4.1 or 607.4.2.

**Exception:** Grab bars shall not be required to be installed in a bathing facility for a single occupant accessed only through a private office and not for common use or public use, provided reinforcement has been installed in walls and located so as to permit the installation of grab bars complying with Section 607.4.

**607.4.1 Bathtubs with permanent seats.** For bathtubs with permanent seats, grab bars complying with Section 607.4.1 shall be provided.

**Figure 607.4.1(A) Grab Bars for Bathtubs with Seat at Head End of Tub - Elevation**

**Figure 607.4.1(B) Grab Bars for Bathtubs with Seat at Head End of Tub - Plan**

**607.4.1.1 Back wall.** Two horizontal grab bars shall be provided on the back wall, one complying with Section 609.4 and the other located 8 inches (205 mm) minimum and 10 inches (255 mm) maximum above the rim of the bathtub. Each grab bar shall be located 15 inches (380 mm) maximum from the head end wall and extend to 12 inches (305 mm) maximum from the control end wall.

**607.4.1.2 Control end wall.** Control end wall grab bars shall comply with Section 607.4.1.2.

**Exception:** An L-shaped continuous grab bar of equivalent dimensions and positioning shall be permitted to serve the function of separate vertical and horizontal grab bars.

**607.4.1.2.1 Horizontal grab bar.** A horizontal grab bar 24 inches (610 mm) minimum in length shall be provided on the control end wall beginning near the front edge of the bathtub and extending toward the inside corner of the bathtub.

**607.4.1.2.2 Vertical grab bar.** A vertical grab bar 18 inches (455 mm) minimum in length shall be provided on the control end wall 3 inches (75 mm) minimum and 6 inches (150 mm) maximum above the horizontal grab bar, and 4 inches (100 mm) maximum inward from the front edge of the bathtub.

**607.4.2 Bathtubs with removable in-tub seats.** For bathtubs with removable in-tub seats, grab bars complying with Section 607.4.2 shall be provided.

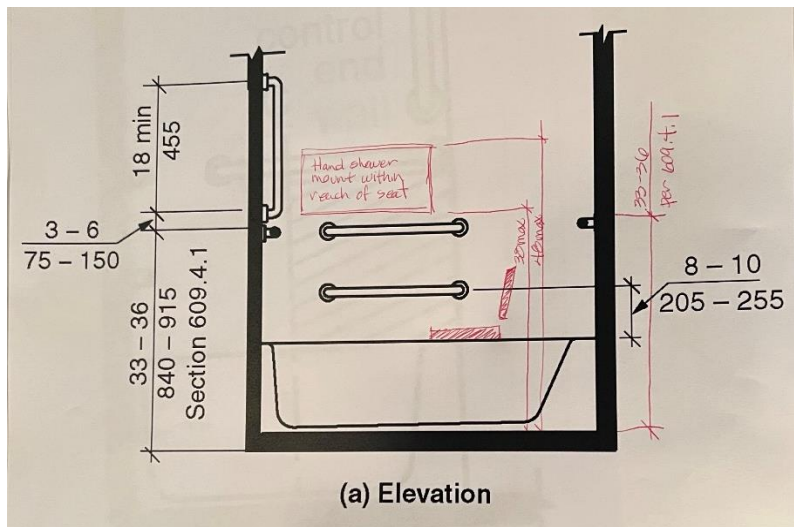


Figure 607.4.2(A) Grab Bars for Bathtubs with Removable In-tub Seats – Elevation  
*Note – seat would have to move forward in graphic*

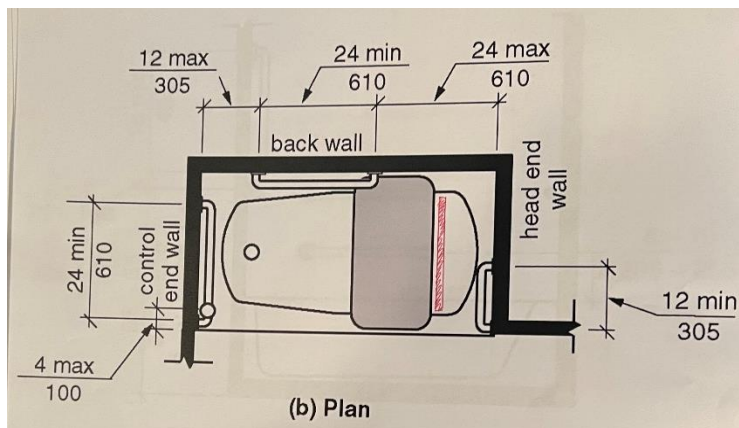


Figure 607.4.2(B) Grab Bars for Bathtubs with Removable In-tub Seats - Plan  
*Note – seat would have to move forward in graphic*

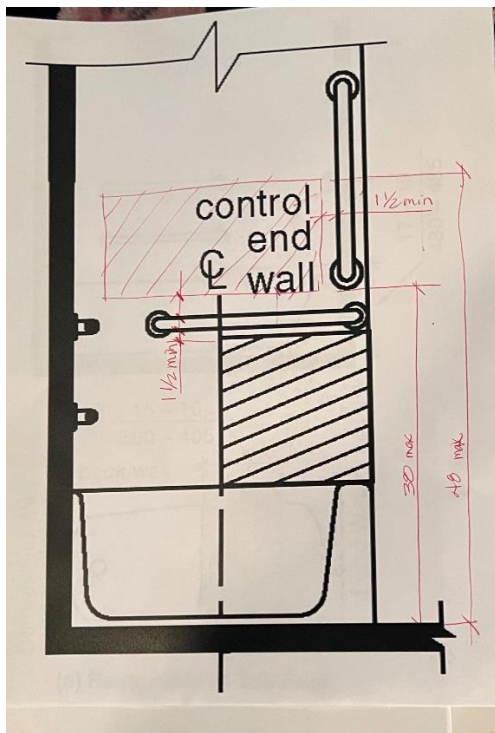
**607.4.2.1 Back wall.** Two horizontal grab bars shall be provided on the back wall, one complying with Section 609.4 and the other located 8 inches (205 mm) minimum and 10 inches (255 mm) maximum above the rim of the bathtub. Each grab bar shall be 24 inches (610 mm) minimum in length, located 24 inches (610 mm) maximum from the head end wall and extend to 12 inches (305 mm) maximum from the control end wall.

**607.4.2.2 Control end wall.** Control end wall grab bars shall comply with Section 607.4.1.2.

**607.4.2.3 Head end wall.** A horizontal grab bar 12 inches (305 mm) minimum in length shall be provided on the head end wall at the front edge of the bathtub.

*(Note - see task group recommendation for controls in 06-49)*

**607.5 Controls.** Controls, other than drain stoppers, shall be provided on an end wall, located between the bathtub rim and grab bar, and between the open side of the bathtub and the centerline of the width of the bathtub. Controls shall comply with Section 309.4.



**FIGURE 607.5**  
**LOCATION OF BATHTUB CONTROLS**

*(Note - see task group recommendation for mounts for hand showers in 06-49)*

**607.6 Hand shower.** A hand shower with a hose 59 inches (1500 mm) minimum in length, that can be used as both a fixed shower head and as a hand shower, shall be provided. The hand shower shall have a control with a nonpositive shut-off feature. Where provided, an

adjustable-height hand shower mounted on a vertical bar shall be installed so as to not obstruct the use of grab bars.

**607.7 Bathtub enclosures.** Enclosures for bathtubs shall not obstruct controls, faucets, shower and spray units or obstruct transfer from wheelchairs onto bathtub seats or into bathtubs. Enclosures on bathtubs shall not have tracks installed on the rim of the bathtub.

**607.8 Water temperature.** Bathtubs shall deliver water that is 120°F (49°C) maximum.

## **SECTION 609 GRAB BARS**

**609.1 General.** Grab bars in toilet or bathing facilities shall comply with Section 609.

**609.2 Cross section.** Grab bars shall have a cross section complying with Section 609.2.1 or 609.2.2.

### **Figure 609.2 Size of Grab Bars**

**609.2.1 Circular cross section.** Grab bars with a circular cross section shall have an outside diameter of 1¼ inch (32 mm) minimum and 2 inches (51 mm) maximum.

**609.2.2 Noncircular cross section.** Grab bars with a noncircular cross section shall have a cross section dimension of 2 inches (51 mm) maximum, and a perimeter dimension of 4 inches (100 mm) minimum and 4.8 inches (120 mm) maximum.

**609.3 Spacing.** The space between the wall and the grab bar shall be 1-1/2 inches (38 mm). The space between the grab bar and projecting objects below and at the ends of the grab bar shall be 1-1/2 inches (38 mm) minimum. The space between the grab bar and projecting objects above the grab bar shall be 12 inches (305 mm) minimum.

#### **Exceptions:**

1. The space between the grab bars and shower controls, shower fittings, and other grab bars above the grab bar shall be permitted to be 1½ inches (38 mm) minimum.
2. Recessed dispensers projecting from the wall ¼ inch (6.4 mm) maximum measured from the face of the dispenser and complying with Section 604.7 shall be permitted within the 12-inch (305 mm) space above and the 1½-inch (38 mm) spaces below and at the ends of the grab bar.

### **Figure 609.3 Spacing of Grab Bars**

#### **609.4 Position of grab bars.**

**609.4.1 General.** Grab bars shall be installed in a horizontal position, 33 inches (840 mm) minimum and 36 inches (915 mm) maximum above the floor measured to the top of the gripping surface or shall be installed as required by Items 1 through 3.

1. The lower grab bar on the back wall of a bathtub shall comply with Section 607.4.1.1 or 607.4.2.1.

2. Vertical grab bars shall comply with Sections 604.5.1.2, 607.4.1.2.2, 607.4.2.2 and 608.3.1.2.

3. Grab bars at water closets primarily for children's use shall comply with Section 609.4.2.

**609.4.2 Position of children's grab bars.** At water closets primarily for children's use complying with Section 604.11, grab bars shall be installed in a horizontal position 18 inches (455 mm) minimum and 27 inches (685 mm) maximum above the floor measured to the top of the gripping surface. A vertical grab bar shall be mounted with the bottom of the bar located between 21 inches (535 mm) minimum and 30 inches (760 mm) maximum above the floor and with the centerline of the bar located between 34 inches (865 mm) minimum and 36 inches (915 mm) maximum from the rear wall.

**Figure 609.4.2(A) Positions of Children's Grab Bars - Side-wall View**

**Figure 609.4.2(B) Positions of Children's Grab Bars - Rear-wall View**

**609.5 Surface hazards.** Grab bars and any wall or other surfaces adjacent to grab bars shall be free of sharp or abrasive elements. Edges shall be rounded.

**609.6 Fittings.** Grab bars shall not rotate within their fittings.

**609.7 Installation and configuration.** Grab bars shall be installed in any manner that provides a gripping surface at the locations specified in this standard and does not obstruct the clear floor space. Horizontal and vertical grab bars shall be permitted to be separate bars, a single piece bar, or combination thereof.

**609.8 Structural strength.** Allowable stresses shall not be exceeded for materials used where a vertical or horizontal force of 250 pounds (1112 N) is applied at any point on the grab bar, fastener mounting device, or supporting structure.

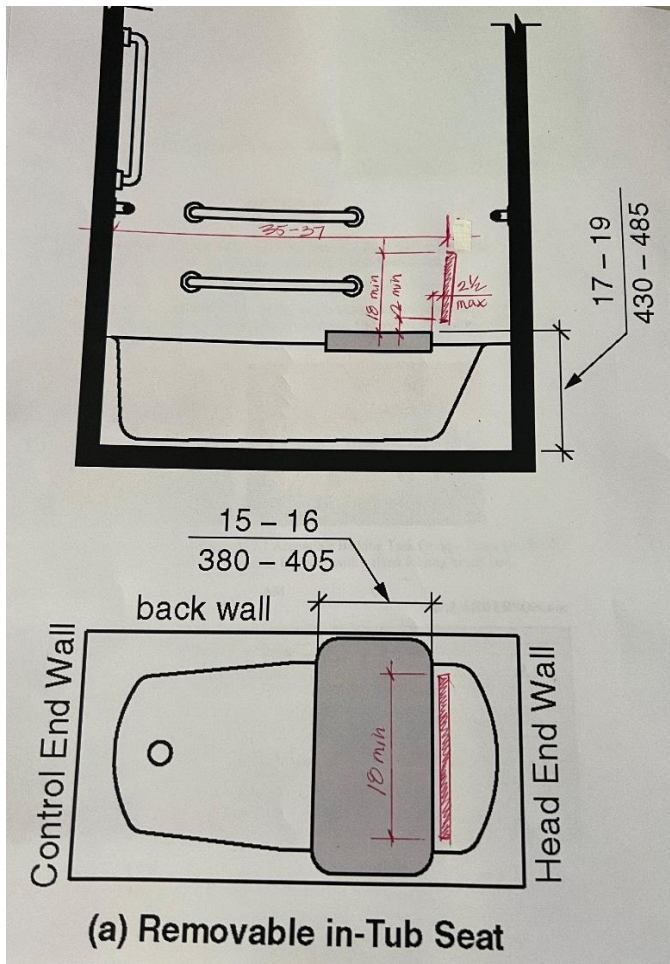
## SECTION 610 SEATS

**610.1 General.** Seats in bathtubs and shower compartments shall comply with Section 610.

**610.2 Bathtub seats.** The height of bathtub seats shall be 17 inches (430 mm) minimum and 19 inches (485 mm) maximum above the bathroom floor, measured to the top of the seat.

**610.2.1 Removable in-tub seats.** Removable in-tub seats shall be 15 inches (380 mm) minimum and 16 inches (405 mm) maximum in depth. The seat shall provide back support with the top edge of the back support 18 inches (455 mm) minimum above the seat surface. Removable in-tub seats shall be capable of secure placement with the rear edge of the seat surface positioned 36 inches (914 mm) maximum from the control wall.





**FIGURE 610.2(A) 610.2.1  
BATHTUB SEATS  
REMOVABLE IN-TUB SEATS**

*Note – seat would have to move forward in graphic; add dimensions in the final text to the graphic*

**610.2.2 Permanent seats.** Permanent-seats shall be 15 inches (380 mm) minimum in depth and shall extend from the back wall to or beyond the outer edge of the bathtub. Permanent seats shall be positioned at the head end of the bathtub.

**FIGURE 610.2(B) 610.2.2  
BATHTUB SEATS  
SEAT PROVIDED AT HEAD END OF TUB**

**610.3 Shower compartment seats.** The height of shower compartment seats shall be 17 inches (430 mm) minimum and 19 inches (485 mm) maximum above the bathroom floor, measured to

the top of the seat. In transfer-type and alternate roll-in-type showers, the seat shall extend along the seat wall to a point within 3 inches (75 mm) of the compartment entry. In standard roll-in-type showers, the seat shall extend from the control wall to a point within 3 inches (75 mm) of the compartment entry. Seats shall comply with Section 610.3.1 or 610.3.2.

**610.3.1 Rectangular seats.** The rear edge of a rectangular seat shall be 2½ inches (64 mm) maximum and the front edge 15 inches (380 mm) minimum and 16 inches (405 mm) maximum from the seat wall. The side edge of the seat shall be 1½ inches (38 mm) maximum from the back wall of a transfer-type shower and 1½ inches (38 mm) maximum from the control wall of a roll-in-type shower.

Figure 610.3.1 Rectangular Shower Compartment Seats

**610.3.2 L-shaped seats.** The rear edge of an L-shaped seat shall be 2½ inches (64 mm) maximum and the front edge 15 inches (380 mm) minimum and 16 inches (405 mm) maximum from the seat wall. The rear edge of the “L” portion of the seat shall be 1½ inches (38 mm) maximum from the wall and the front edge shall be 14 inches (355 mm) minimum and 15 inches (380 mm) maximum from the wall. The end of the “L” shall be 22 inches (560 mm) minimum and 23 inches (585 mm) maximum from the main seat wall.

Figure 610.3.2 L-shaped Shower Compartment Seats

**610.4 Structural strength.** Allowable stresses shall not be exceeded for materials used where a vertical or horizontal force of 250 pounds (1112 N) is applied at any point on the seat, fastener mounting device, or supporting structure.

Reason:

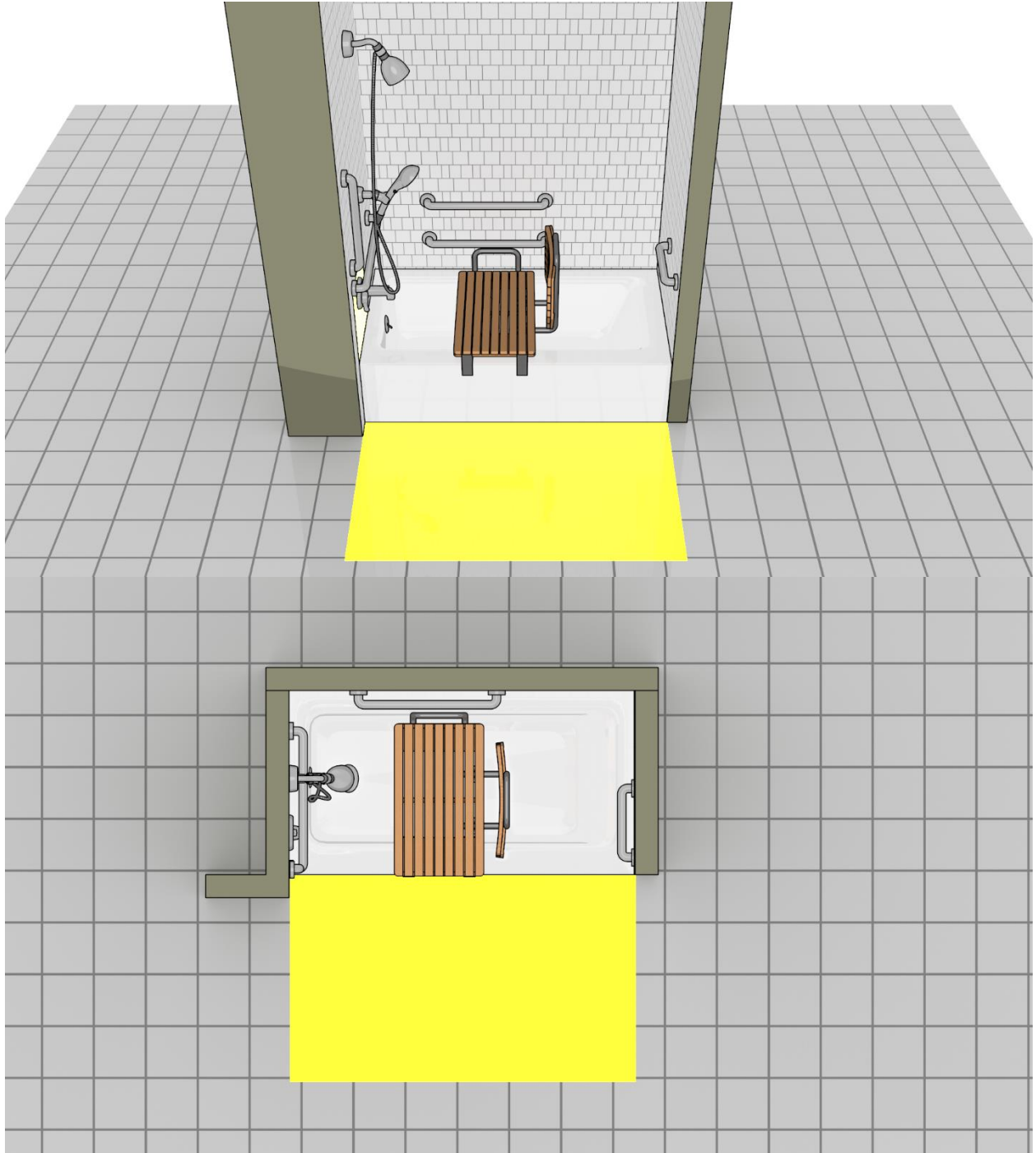
Purpose - The task group would like a seat back, but there were no examples of seats with backs that met all of the discussed criteria. The task group would like input from the industry on the back size and any structural/attachment considerations.

Change term to ‘removeable in-tub seat’ for consistency throughout the document.

Have the seat be capable of being located within reach of the controls.

The clarification of the controls and mount for the hand shower will be addressed in the task group modification to 06-49.





Committee Action: Approval As Modified 17-8-4

**REPORT OF HEARING:**

**Modification (if any):** Proposals 06-41, 06-42, 06-45, 06-50 and 06-81 are all related to bathtubs. Modifications to 06-41, 06-42 and 06-45 will replace the 5 proposal (separated by section) with 3 proposals (separated to one for each type of bathtub seat configuration).

See the replacement proposal above to see the changes in context. The Report of Hearing will only indicate the changes to text and titles of figures. Revisions to the figures is the responsibility of the Editorial committee. It was noted that the task group did not have sufficient time to fully update the graphics submitted.

**607.4.2 Bathtubs with removable in-tub seats.** For bathtubs with removable in-tub seats, grab bars complying with Section 607.4.2 shall be provided.

Figure 607.4.2(A) Grab Bars for Bathtubs with Removable In-tub Seats – Elevation

Figure 607.4.2(B) Grab Bars for Bathtubs with Removable In-tub Seats - Plan

*(Note - see task group recommendation for controls and hand showers in 06-49)*

**610.2 Bathtub seats.** The height of bathtub seats shall be 17 inches (430 mm) minimum and 19 inches (485 mm) maximum above the bathroom floor, measured to the top of the seat.

**610.2.1 Removable in-tub seats.** Removable in-tub seats shall be 15 inches (380 mm) minimum and 16 inches (405 mm) maximum in depth. The seat shall provide back support with the top edge of the back support 18 inches (455 mm) minimum above the seat surface. Removable in-tub seats shall be capable of secure placement with the rear edge of the seat surface positioned 36 inches (914 mm) maximum from the control wall.

**FIGURE ~~610.2(A)~~ 610.2.1  
BATHTUB SEATS  
REMOVABLE IN-TUB SEATS**

**610.2.2 Permanent seats.** Permanent-seats shall be 15 inches (380 mm) minimum in depth and shall extend from the back wall to or beyond the outer edge of the bathtub. Permanent seats shall be positioned at the head end of the bathtub.

**FIGURE ~~610.2(B)~~ 610.2.2  
BATHTUB SEATS  
SEAT PROVIDED AT HEAD END OF TUB**

**Committee Reason:** Locating the removable seat within the reach of controls will provide better access for persons using the seat while bathing. Adding a seat back will allow for greater stability. The task group noted that there were no examples of seats with backs currently available that met all of the discussed criteria. The task group would like input from the industry on the back size and any structural/attachment considerations.

**607.2\_ANDERSON**

**Report for 06-41– 2021**

<b>Committee decision:</b> AM	<b>Committee Vote at Meeting:</b> 17-8-4	<b>Committee Vote on Ballot:</b>
-------------------------------	--	----------------------------------

**REPORT OF HEARING:**

Modification (if any):  
 Proposals 06-41, 06-42, 06-45, 06-50 and 06-81 are all related to bathtubs. Modifications to 06-41, 06-42 and 06-45 will replace the 5 proposal (separated by section) with 3 proposals (separated to one for each type of bathtub seat configuration).

See the replacement proposal above to see the changes in context. The Report of Hearing will only indicate the changes to text and titles of figures. Revisions to the figures is the responsibility of the Editorial committee. It was noted that the task group did not have sufficient time to fully update the graphics submitted.

**607.4.2 Bathtubs with removable in-tub seats.** For bathtubs with removable in-tub seats, grab bars complying with Section 607.4.2 shall be provided.

Figure 607.4.2(A) Grab Bars for Bathtubs with Removable In-tub Seats – Elevation  
 Figure 607.4.2(B) Grab Bars for Bathtubs with Removable In-tub Seats - Plan

*(Note - see task group recommendation for controls and hand showers in 06-49)*

**610.2 Bathtub seats.** The height of bathtub seats shall be 17 inches (430 mm) minimum and 19 inches (485 mm) maximum above the bathroom floor, measured to the top of the seat.

**610.2.1 Removable in-tub seats.** Removable in-tub seats shall be 15 inches (380 mm) minimum and 16 inches (405 mm) maximum in depth. The seat shall provide back support with the top edge of the back support 18 inches (455 mm) minimum above the seat surface. Removable in-tub seats shall be capable of secure placement with the rear edge of the seat surface positioned 36 inches (914 mm) maximum from the control wall.

**FIGURE ~~640.2(A)~~ 610.2.1 BATHTUB SEATS REMOVABLE IN-TUB SEATS**

**610.2.2 Permanent seats.** Permanent-seats shall be 15 inches (380 mm) minimum in depth and shall extend from the back wall to or beyond the outer edge of the bathtub. Permanent-seats shall be positioned at the head end of the bathtub.

**FIGURE ~~640.2(B)~~ 610.2.2 BATHTUB SEATS SEAT PROVIDED AT HEAD END OF TUB**

**Committee Reason:** Locating the removable seat within the reach of controls will provide better access for persons using the seat while bathing. Adding a seat back will allow for greater stability. The task group noted that there were no examples of seats with backs currently available that met all of the discussed criteria. The task group would like input from the industry on the back size and any structural/attachment considerations.

**PUBLIC COMMENT- FIRST DRAFT:**

Proponent:  
 Desired Action:  
 Modification:  
 Reason:

<b>Committee decision:</b> AS/AM/D	<b>Committee Vote at Meeting:</b>	<b>Committee Vote on Ballot:</b>
------------------------------------	-----------------------------------	----------------------------------

**REPORT OF HEARING – FIRST DRAFT**

Modification (if any):  
 Committee Reason:

**PUBLIC COMMENT- SECOND DRAFT:**

Proponent:  
 Desired Action:  
 Modification:  
 Reason:

<b>Committee decision:</b> AS/AM/D	<b>Committee Vote at Meeting:</b>	<b>Committee Vote on Ballot:</b>
------------------------------------	-----------------------------------	----------------------------------

**FINAL ACTION:**

Modification (if any):  
 Committee Reason:

## 06-42 – 2021

### 607.3

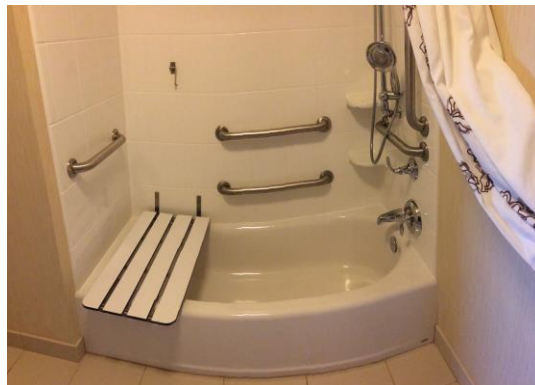
**Proponent:** Doug Anderson, representing A117.1 Accessible Bathing Task Group

**Revise as follows:**

#### SECTION 607 BATHTUBS

**607.3 Seat.** A permanent seat at the head end of the bathtub, a fixed folding in-tub seat or a removable in-tub seat shall be provided. Seats shall comply with Section 610.

**REASON:** The industry is installing fixed folding in-tub seats and is proposing language to provide specifications for the location and adjacent features. The photos are to illustrate what this proposal is talking about.



**Staff Note:** This proposal is from the A117.1 Accessible Bathing Task Group. Proposals 06-41, 06-42, 06-45, 06-50 and 06-81 are all related to bathtubs with a fixed folding in-tub seat.

## 06-42 – 2021 Replacement

**607.2, Figure 607.2(B), 607.3, 607.4.1, Figure 607.4.1(A), Figure 607.4.2(B), 610.2, 610.2.1(New), 610.2.2(New), Figure 601.2(B)**

**Proponent:** Doug Anderson, representing A117.1 Accessible Bathing Task Group

Note: Proposals 06-41, 06-42, 06-45, 06-50 and 06-81 are all related to bathtubs. Modifications to 06-41, 06-42 and 06-45 will replace the 5 proposals (separated by section) with 3 proposals (separated to one for each type of bathtub seat configuration).

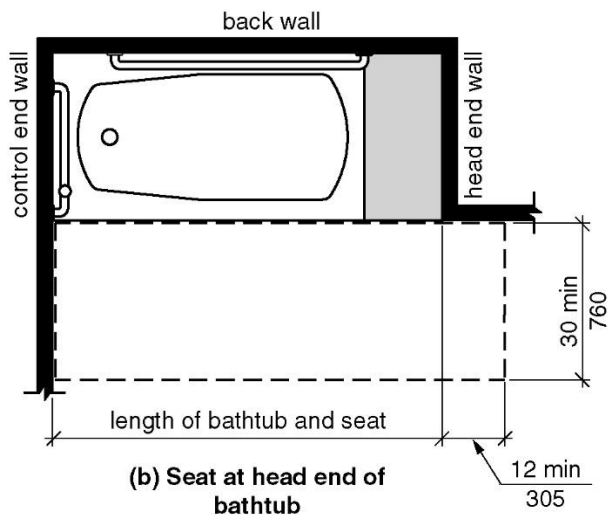
Replace with the following:

## SECTION 607 BATHTUBS

**607.1 General.** Bathtubs shall comply with Section 607.

**607.2 Clearance.** A clearance in front of bathtubs extending the length of the bathtub and 30 inches (760 mm) minimum in depth shall be provided. Where a ~~permanent seat~~ transfer platform is provided at the head end of the bathtub, the clearance shall extend 12 inches (305 mm) minimum beyond the wall at the head end of the bathtub.

**FIGURE 607.2(A)**  
**CLEARANCE FOR BATHTUBS WITH REMOVABLE IN TUB SEATS**



**FIGURE 607.2(B)**  
**CLEARANCE FOR BATHTUBS WITH TRANSFER PLATFORMS SEAT AT HEAD END OF TUB**

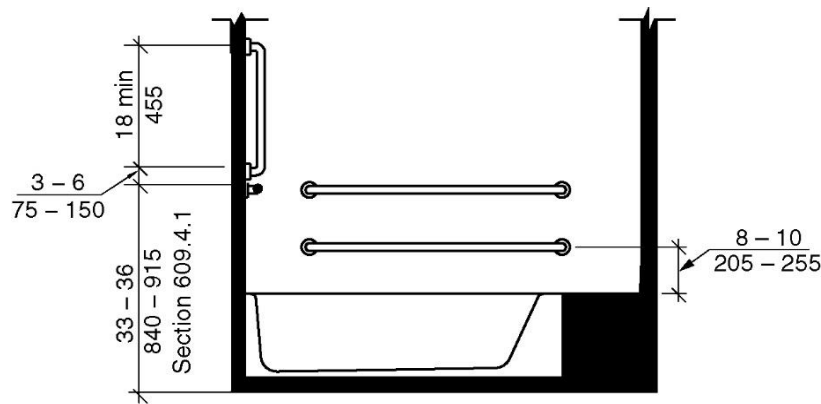
*Note: Add removeable seat to drawing*

**607.3 Seats.** A ~~permanent seat at the head end of the bathtub or a~~ removable in-tub seat shall be provided. Removable in-tub Seats and transfer platforms shall comply with Section 610.

**607.4 Grab bars.** Grab bars shall comply with Section 609 and shall be provided in accordance with Section 607.4.1 or 607.4.2.

**Exception:** Grab bars shall not be required to be installed in a bathing facility for a single occupant accessed only through a private office and not for common use or public use, provided reinforcement has been installed in walls and located so as to permit the installation of grab bars complying with Section 607.4.

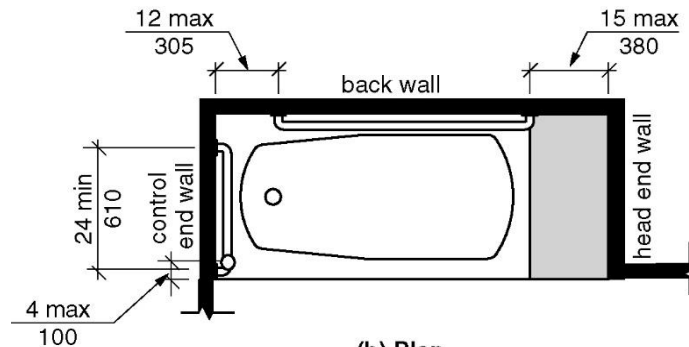
**607.4.1 Bathtubs with permanent seats transfer platforms.** For bathtubs with permanent seats transfer platforms, grab bars complying with Section 607.4.1 shall be provided.



(a) Elevation

Figure 607.4.1(A) Grab Bars for Bathtubs with Seat-Transfer Platforms at Head End of Tub – Elevation

*Note: Add removable seat to drawing*



(b) Plan

Figure 607.4.1(B) Grab Bars for Bathtubs with Seat-Transfer Platforms at Head End of Tub – Plan

*Note: Add removable seat to drawing*

**607.4.1.1 Back wall.** Two horizontal grab bars shall be provided on the back wall, one complying with Section 609.4 and the other located 8 inches (205 mm) minimum and 10 inches (255 mm) maximum above the rim of the bathtub. Each grab bar shall be located 15 inches (380 mm) maximum from the head end wall and extend to 12 inches (305 mm) maximum from the control end wall.

**607.4.1.2 Control end wall.** Control end wall grab bars shall comply with Section 607.4.1.2.

**Exception:** An L-shaped continuous grab bar of equivalent dimensions and positioning shall be permitted to serve the function of separate vertical and horizontal grab bars.

**607.4.1.2.1 Horizontal grab bar.** A horizontal grab bar 24 inches (610 mm) minimum in length shall be provided on the control end wall beginning near the front edge of the bathtub and extending toward the inside corner of the bathtub.

**607.4.1.2.2 Vertical grab bar.** A vertical grab bar 18 inches (455 mm) minimum in length shall be provided on the control end wall 3 inches (75 mm) minimum and 6 inches (150 mm) maximum above the horizontal grab bar, and 4 inches (100 mm) maximum inward from the front edge of the bathtub.

**607.4.2 Bathtubs with removable seats.** For bathtubs with removable seats, grab bars complying with Section 607.4.2 shall be provided.

**Figure 607.4.2(A) Grab Bars for Bathtubs with Removable Seats – Elevation**  
**Figure 607.4.2(B) Grab Bars for Bathtubs with Removable Seats - Plan**

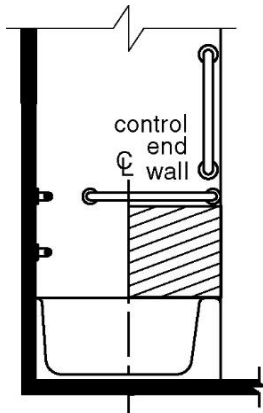
**607.4.2.1 Back wall.** Two horizontal grab bars shall be provided on the back wall, one complying with Section 609.4 and the other located 8 inches (205 mm) minimum and 10 inches (255 mm) maximum above the rim of the bathtub. Each grab bar shall be 24 inches (610 mm) minimum in length, located 24 inches (610 mm) maximum from the head end wall and extend to 12 inches (305 mm) maximum from the control end wall.

**607.4.2.2 Control end wall.** Control end wall grab bars shall comply with Section 607.4.1.2.

**607.4.2.3 Head end wall.** A horizontal grab bar 12 inches (305 mm) minimum in length shall be provided on the head end wall at the front edge of the bathtub.

*(Note - see task group recommendation for controls in 06-49)*

**607.5 Controls.** Controls, other than drain stoppers, shall be provided on an end wall, located between the bathtub rim and grab bar, and between the open side of the bathtub and the centerline of the width of the bathtub. Controls shall comply with Section 309.4.



**FIGURE 607.5**  
**LOCATION OF BATHTUB CONTROLS**

*(Note - see task group recommendation for controls in 06-49)*

**607.6 Hand shower.** A hand shower with a hose 59 inches (1500 mm) minimum in length, that can be used as both a fixed shower head and as a hand shower, shall be provided. The



hand shower shall have a control with a nonpositive shut-off feature. Where provided, an adjustable-height hand shower mounted on a vertical bar shall be installed so as to not obstruct the use of grab bars.

**607.7 Bathtub enclosures.** Enclosures for bathtubs shall not obstruct controls, faucets, shower and spray units or obstruct transfer from wheelchairs onto bathtub seats or into bathtubs. Enclosures on bathtubs shall not have tracks installed on the rim of the bathtub.

**607.8 Water temperature.** Bathtubs shall deliver water that is 120°F (49°C) maximum.

## **SECTION 609 GRAB BARS**

**609.1 General.** Grab bars in toilet or bathing facilities shall comply with Section 609.

**609.2 Cross section.** Grab bars shall have a cross section complying with Section 609.2.1 or 609.2.2.

### **Figure 609.2 Size of Grab Bars**

**609.2.1 Circular cross section.** Grab bars with a circular cross section shall have an outside diameter of 1¼ inch (32 mm) minimum and 2 inches (51 mm) maximum.

**609.2.2 Noncircular cross section.** Grab bars with a noncircular cross section shall have a cross section dimension of 2 inches (51 mm) maximum, and a perimeter dimension of 4 inches (100 mm) minimum and 4.8 inches (120 mm) maximum.

**609.3 Spacing.** The space between the wall and the grab bar shall be 1½ inches (38 mm). The space between the grab bar and projecting objects below and at the ends of the grab bar shall be 1½ inches (38 mm) minimum. The space between the grab bar and projecting objects above the grab bar shall be 12 inches (305 mm) minimum.

#### **Exceptions:**

1. The space between the grab bars and shower controls, shower fittings, and other grab bars above the grab bar shall be permitted to be 1½ inches (38 mm) minimum.
2. Recessed dispensers projecting from the wall ¼ inch (6.4 mm) maximum measured from the face of the dispenser and complying with Section 604.7 shall be permitted within the 12-inch (305 mm) space above and the 1½-inch (38 mm) spaces below and at the ends of the grab bar.

### **Figure 609.3 Spacing of Grab Bars**

#### **609.4 Position of grab bars.**

**609.4.1 General.** Grab bars shall be installed in a horizontal position, 33 inches (840 mm) minimum and 36 inches (915 mm) maximum above the floor measured to the top of the gripping surface or shall be installed as required by Items 1 through 3.



1. The lower grab bar on the back wall of a bathtub shall comply with Section 607.4.1.1 or 607.4.2.1.
2. Vertical grab bars shall comply with Sections 604.5.1.2, 607.4.1.2.2, 607.4.2.2 and 608.3.1.2.
3. Grab bars at water closets primarily for children's use shall comply with Section 609.4.2.

**609.4.2 Position of children's grab bars.** At water closets primarily for children's use complying with Section 604.11, grab bars shall be installed in a horizontal position 18 inches (455 mm) minimum and 27 inches (685 mm) maximum above the floor measured to the top of the gripping surface. A vertical grab bar shall be mounted with the bottom of the bar located between 21 inches (535 mm) minimum and 30 inches (760 mm) maximum above the floor and with the centerline of the bar located between 34 inches (865 mm) minimum and 36 inches (915 mm) maximum from the rear wall.

**Figure 609.4.2(A) Positions of Children's Grab Bars - Side-wall View**

**Figure 609.4.2(B) Positions of Children's Grab Bars - Rear-wall View**

**609.5 Surface hazards.** Grab bars and any wall or other surfaces adjacent to grab bars shall be free of sharp or abrasive elements. Edges shall be rounded.

**609.6 Fittings.** Grab bars shall not rotate within their fittings.

**609.7 Installation and configuration.** Grab bars shall be installed in any manner that provides a gripping surface at the locations specified in this standard and does not obstruct the clear floor space. Horizontal and vertical grab bars shall be permitted to be separate bars, a single piece bar, or combination thereof.

**609.8 Structural strength.** Allowable stresses shall not be exceeded for materials used where a vertical or horizontal force of 250 pounds (1112 N) is applied at any point on the grab bar, fastener mounting device, or supporting structure.

## **SECTION 610 SEATS**

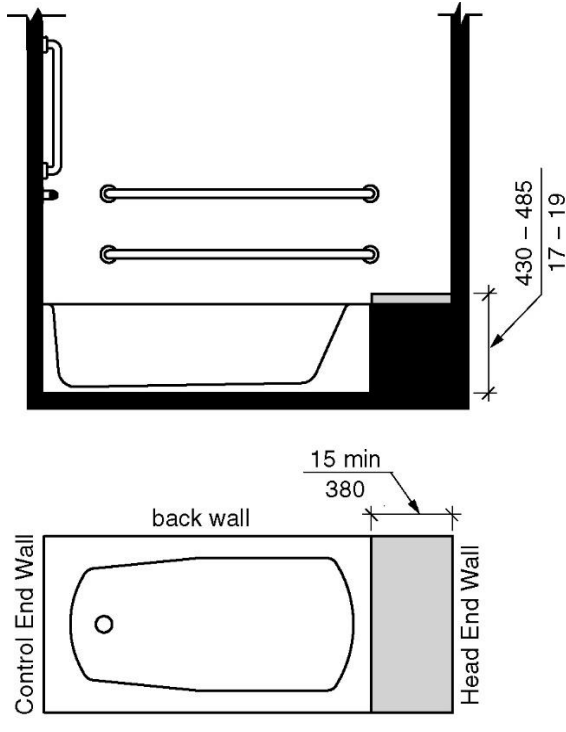
**610.1 General.** Seats in bathtubs and shower compartments shall comply with Section 610.

**610.2 Bathtub seats.** The height of bathtub seats shall be 17 inches (430 mm) minimum and 19 inches (485 mm) maximum above the bathroom floor, measured to the top of the seat.

**610.2.1 Removable in-tub seats.** Removable in-tub seats shall be 15 inches (380 mm) minimum and 16 inches (405 mm) maximum in depth. Removable in-tub seats shall be capable of secure placement.

### **FIGURE ~~610.2(A)~~ 610.2.1 BATHTUB SEATS REMOVABLE IN-TUB SEATS**

**610.2.2 Bathtubs with transfer platforms.** ~~Permanent seats~~ Transfer platforms shall be 15 inches (380 mm) minimum in depth and shall extend from the back wall to or beyond the outer edge of the bathtub. ~~Permanent seats~~ Transfer platforms shall be positioned at the head end of the bathtub.



**FIGURE 610.2(B) 610.2.2  
BATH TUB SEATS**

**SEAT TRANSFER PLATFORM PROVIDED AT HEAD END OF TUB**

*Note: Show removeable seat in figures*

**610.3 Shower compartment seats.** The height of shower compartment seats shall be 17 inches (430 mm) minimum and 19 inches (485 mm) maximum above the bathroom floor, measured to the top of the seat. In transfer-type and alternate roll-in-type showers, the seat shall extend along the seat wall to a point within 3 inches (75 mm) of the compartment entry. In standard roll-in-type showers, the seat shall extend from the control wall to a point within 3 inches (75 mm) of the compartment entry. Seats shall comply with Section 610.3.1 or 610.3.2.

**610.3.1 Rectangular seats.** The rear edge of a rectangular seat shall be 2½ inches (64 mm) maximum and the front edge 15 inches (380 mm) minimum and 16 inches (405 mm) maximum from the seat wall. The side edge of the seat shall be 1½ inches (38 mm) maximum from the back wall of a transfer-type shower and 1½ inches (38 mm) maximum from the control wall of a roll-in-type shower.

**Figure 610.3.1 Rectangular Shower Compartment Seats**

**610.3.2 L-shaped seats.** The rear edge of an L-shaped seat shall be 2½ inches (64 mm) maximum and the front edge 15 inches (380 mm) minimum and 16 inches (405 mm) maximum from the seat wall. The rear edge of the “L” portion of the seat shall be 1½ inches

(38 mm) maximum from the wall and the front edge shall be 14 inches (355 mm) minimum and 15 inches (380 mm) maximum from the wall. The end of the “L” shall be 22 inches (560 mm) minimum and 23 inches (585 mm) maximum from the main seat wall.

**Figure 610.3.2 L-shaped Shower Compartment Seats**

**610.4 Structural strength.** Allowable stresses shall not be exceeded for materials used where a vertical or horizontal force of 250 pounds (1112 N) is applied at any point on the seat, fastener mounting device, or supporting structure.

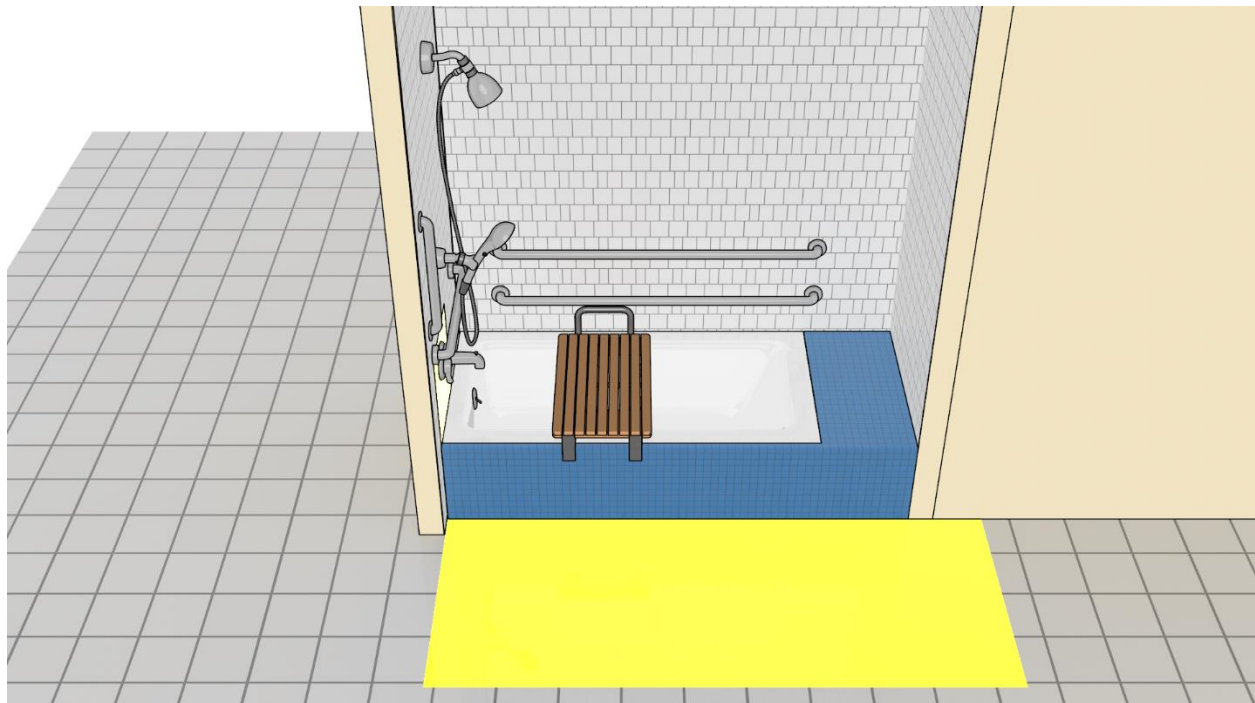
Reason:

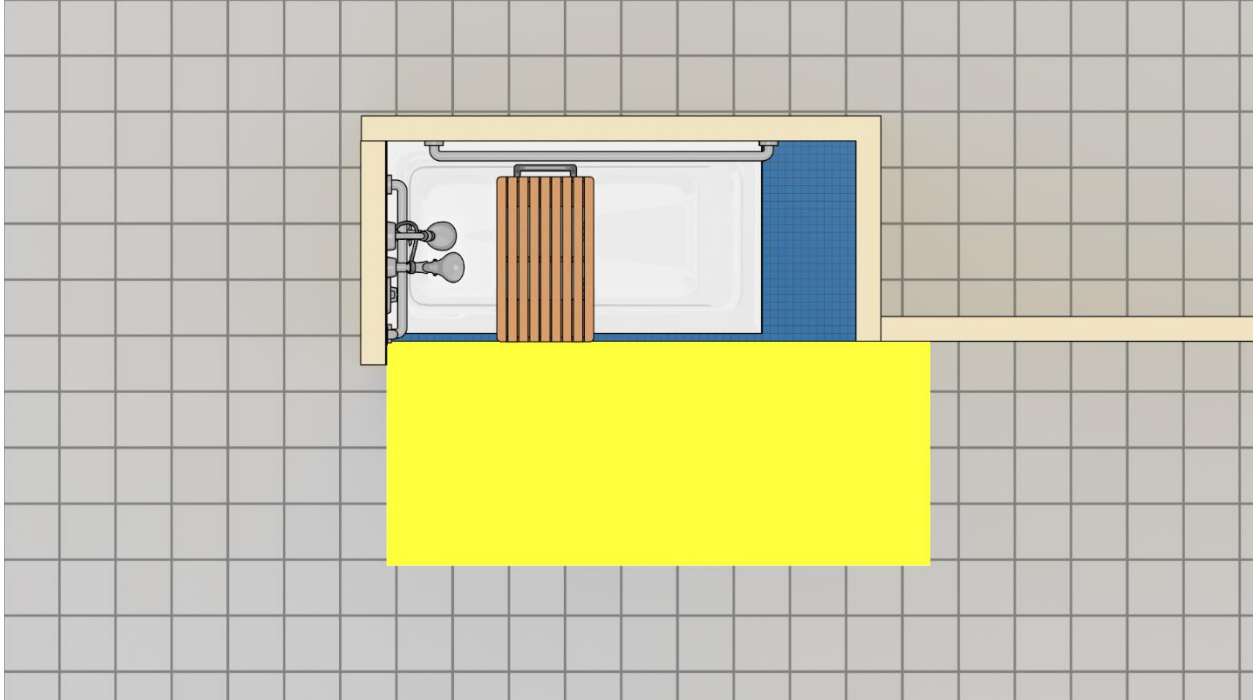
Purpose -Want to require moveable seat in bathtub with fixed head end seat option as the fixed head end seat is not good for bathing on the seat. However, the fixed head end seat is the only good way we know of to be able to transfer down into the tub for someone who does not want a seat, so this option should remain.

Change name from ‘fixed head end seat’ or ‘permanent seat’ to ‘transfer platform’ so differences are easier to understand.

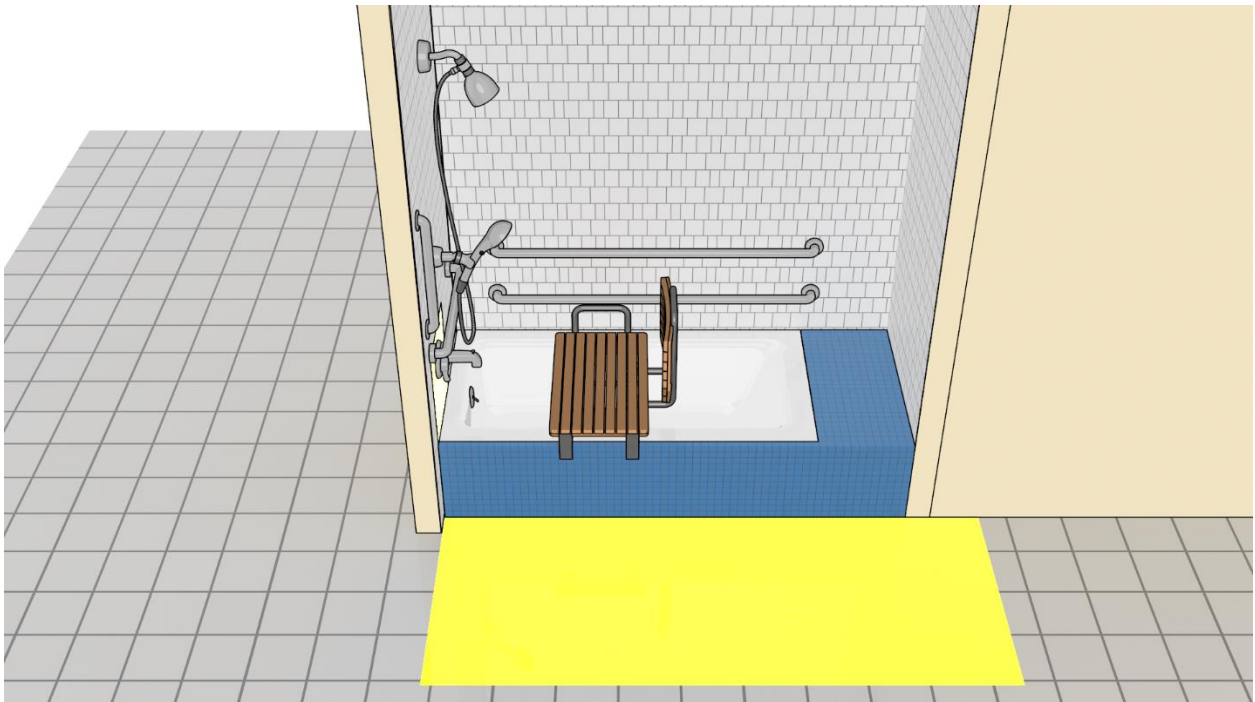
If the removable seat will have a back or not is dependent on the committee decision for removeable seats.

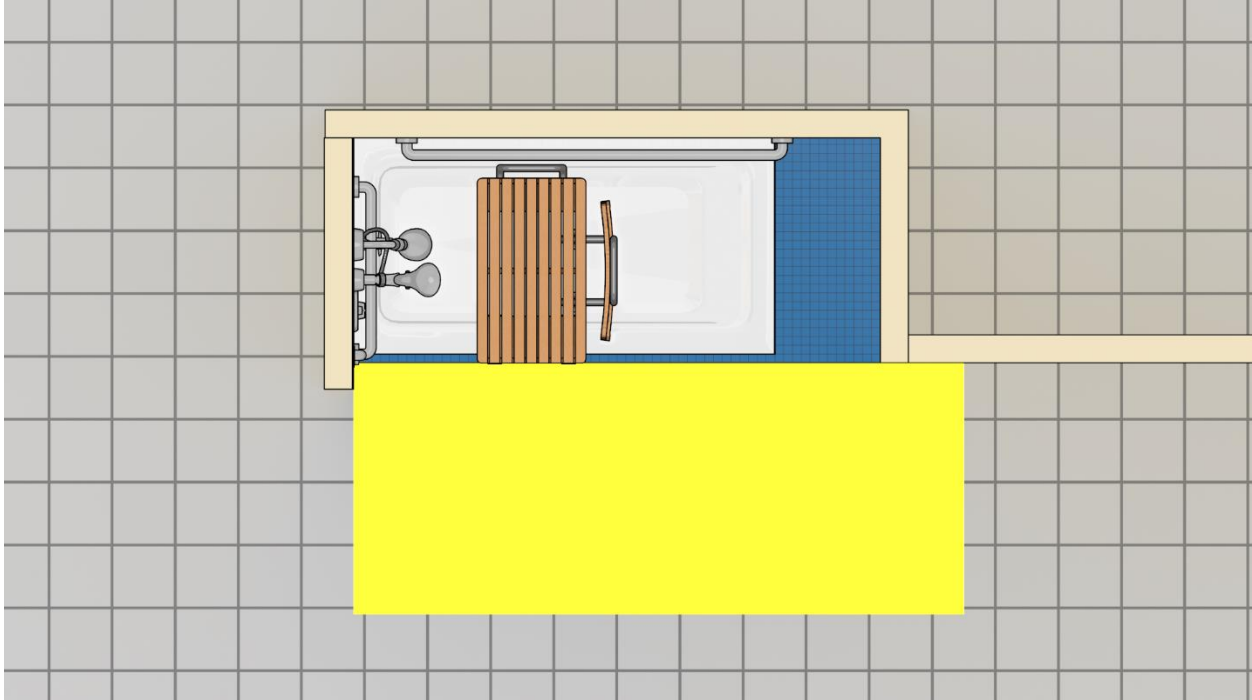
The clarification of the controls and mount for the hand shower will be addressed in the task group modification to 06-49.





Option without seat back on removeable seat.





Option with seat back on removeable seat.

---

Committee Action: Approval As Modified 22-7-0

### REPORT OF HEARING:

**Modification (if any):** Proposals 06-41, 06-42, 06-45, 06-50 and 06-81 are all related to bathtubs. Modifications to 06-41, 06-42 and 06-45 will replace the 5 proposal (separated by section) with 3 proposals (separated to one for each type of bathtub seat configuration).

See the replacement proposal above to see the changes in context. The Report of Hearing will only indicate the changes to text and titles of figures. Revisions to the figures is the responsibility of the Editorial committee. It was noted that the task group did not have sufficient time to fully update the graphics submitted.

**607.2 Clearance.** A clearance in front of bathtubs extending the length of the bathtub and 30 inches (760 mm) minimum in depth shall be provided. Where a permanent seat transfer platform is provided at the head end of the bathtub, the clearance shall extend 12 inches (305 mm) minimum beyond the wall at the head end of the bathtub.

### FIGURE 607.2(B) CLEARANCE FOR BATHTUBS WITH TRANSFER PLATFORMS SEAT AT HEAD END OF TUB

**607.3 Seats.** A permanent seat at the head end of the bathtub or a removable in-tub seat shall be provided. Removable in-tub Seats and transfer platforms shall comply with Section 610.

**607.4 Grab bars.** Grab bars shall comply with Section 609 and shall be provided in accordance with Section 607.4.1 or 607.4.2.

**Exception:** Grab bars shall not be required to be installed in a bathing facility for a single occupant accessed only through a private office and not for common use or public use, provided reinforcement has been installed in walls and located so as to permit the installation of grab bars complying with Section 607.4.

**607.4.1 Bathtubs with ~~permanent seats~~ transfer platforms.** For bathtubs with ~~permanent seats~~ transfer platforms, grab bars complying with Section 607.4.1 shall be provided.

**Figure 607.4.1(A) Grab Bars for Bathtubs with Seat-Transfer Platforms at Head End of Tub – Elevation**

**Figure 607.4.1(B) Grab Bars for Bathtubs with Seat-Transfer Platforms at Head End of Tub – Plan**

*(Note - see task group recommendation for controls and hand showers in 06-49)*

**610.2 Bathtub seats.** The height of bathtub seats shall be 17 inches (430 mm) minimum and 19 inches (485 mm) maximum above the bathroom floor, measured to the top of the seat.

**610.2.1 Removable in-tub seats.** Removable in-tub seats shall be 15 inches (380 mm) minimum and 16 inches (405 mm) maximum in depth. Removable in-tub seats shall be capable of secure placement.

**FIGURE ~~610.2(A)~~ 610.2.1 BATHTUB SEATS-REMOVABLE IN-TUB SEATS**

**610.2.2 Bathtubs with transfer platforms.** ~~Permanent seats~~ Transfer platforms shall be 15 inches (380 mm) minimum in depth and shall extend from the back wall to or beyond the outer edge of the bathtub. ~~Permanent seats~~ Transfer platforms shall be positioned at the head end of the bathtub.

**FIGURE ~~610.2(B)~~ 610.2.2 BATHTUB SEATS SEAT TRANSFER PLATFORM PROVIDED AT HEAD END OF TUB**

**Committee Reason:** The ‘head end seat’ as currently written does not work well for someone to bath. It appears to be more for someone to transfer to move into the tub from the head end. Therefore, changing the name to a transfer platform is appropriate. Adding the removable seat within the reach of controls will provide better access for persons using the seat while showering. While a seat with a back (see 06-41) would add additional support, the committee felt that adding the moveable seat improved access with or without a back.

**607.3 ANDERSON.doc**

<b>Report for 06-42– 2021</b>		
<b>Committee decision: AM</b>	<b>Committee Vote at Meeting: 22-7-0</b>	<b>Committee Vote on Ballot:</b>
<b>REPORT OF HEARING:</b>		
Modification (if any):		

**Report for 06-42– 2021**

Proposals 06-41, 06-42, 06-45, 06-50 and 06-81 are all related to bathtubs. Modifications to 06-41, 06-42 and 06-45 will replace the 5 proposal (separated by section) with 3 proposals (separated to one for each type of bathtub seat configuration).

See the replacement proposal above to see the changes in context. The Report of Hearing will only indicate the changes to text and titles of figures. Revisions to the figures is the responsibility of the Editorial committee. It was noted that the task group did not have sufficient time to fully update the graphics submitted.

**607.2 Clearance.** A clearance in front of bathtubs extending the length of the bathtub and 30 inches (760 mm) minimum in depth shall be provided. Where a permanent-seat transfer platform is provided at the head end of the bathtub, the clearance shall extend 12 inches (305 mm) minimum beyond the wall at the head end of the bathtub.

**FIGURE 607.2(B) CLEARANCE FOR BATHTUBS WITH TRANSFER PLATFORMS SEAT AT HEAD END OF TUB**

**607.3 Seats.** A permanent seat at the head end of the bathtub or a removable in-tub seat shall be provided. Removable in-tub Seats and transfer platforms shall comply with Section 610.

**607.4 Grab bars.** Grab bars shall comply with Section 609 and shall be provided in accordance with Section 607.4.1 or 607.4.2.  
**Exception:** Grab bars shall not be required to be installed in a bathing facility for a single occupant accessed only through a private office and not for common use or public use, provided reinforcement has been installed in walls and located so as to permit the installation of grab bars complying with Section 607.4.

**607.4.1 Bathtubs with permanent seats transfer platforms.** For bathtubs with permanent seats transfer platforms, grab bars complying with Section 607.4.1 shall be provided.

**Figure 607.4.1(A) Grab Bars for Bathtubs with Seat-Transfer Platforms at Head End of Tub – Elevation**  
**Figure 607.4.1(B) Grab Bars for Bathtubs with Seat-Transfer Platforms at Head End of Tub – Plan**

*(Note - see task group recommendation for controls and hand showers in 06-49)*

**610.2 Bathtub seats.** The height of bathtub seats shall be 17 inches (430 mm) minimum and 19 inches (485 mm) maximum above the bathroom floor, measured to the top of the seat.

**610.2.1 Removable in-tub seats.** Removable in-tub seats shall be 15 inches (380 mm) minimum and 16 inches (405 mm) maximum in depth. Removable in-tub seats shall be capable of secure placement.

**FIGURE 610.2(A) 610.2.1 BATHTUB SEATS REMOVABLE IN-TUB SEATS**

**610.2.2 Bathtubs with transfer platforms.** Permanent seats Transfer platforms shall be 15 inches (380 mm) minimum in depth and shall extend from the back wall to or beyond the outer edge of the bathtub. Permanent seats Transfer platforms shall be positioned at the head end of the bathtub.

**FIGURE 610.2(B) 610.2.2 BATHTUB SEATS SEAT TRANSFER PLATFORM PROVIDED AT HEAD END OF TUB**

Committee Reason: The 'head end seat' as currently written does not work well for someone to bath. It appears to be more for someone to transfer to move into the tub from the head end. Therefore, changing the name to a transfer platform is appropriate. Adding the removable seat within the reach of controls will provide better access for persons using the seat while showering. While a seat with a back (see 06-41) would add additional support, the committee felt that adding the moveable seat improved access with or without a back.

**PUBLIC COMMENT- FIRST DRAFT:**

Proponent:

Desired Action:

Modification:

Reason:

**Committee decision: AS/AM/D**

**Committee Vote at Meeting:**

**Committee Vote on Ballot:**

**REPORT OF HEARING – FIRST DRAFT**

Modification (if any):

Committee Reason:

**PUBLIC COMMENT- SECOND DRAFT:**

Proponent:

Desired Action:

Modification:

Reason:

**Committee decision: AS/AM/D**

**Committee Vote at Meeting:**

**Committee Vote on Ballot:**

**FINAL ACTION:**

Modification (if any):

Committee Reason:



## 06-43 – 2021

### 607.4

**Proponent:** Marsha Mazz, representing United Spinal Association

**Revise as follows:**

#### SECTION 607 BATHTUBS

**607.4 Grab bars.** Grab bars shall comply with Section 609 and shall be provided in accordance with Section 607.4.1 or 607.4.2. Horizontal grab bar height shall be measured to the top of the gripping surface and vertical grab bars distance from an object shall be measured to the centerline of the bar.

**Exception:** Grab bars shall not be required to be installed in a bathing facility for a single occupant accessed only through a private office and not for common use or public use, provided reinforcement has been installed in walls and located so as to permit the installation of grab bars complying with Section 607.4.

---

**REASON:** Section 609.4 requires horizontal grab bars to be measured to the top of the gripping surface. However, for bathtubs, that section allows an option to comply with Sections 607.4.1.1 (with permanent seats) or Section 607.4.2.1 (with removable seats). We don't believe this should be an option and will propose a correlating change to Section 609.1 to address this and other problems with the requirements.

This proposal specifies that horizontal grab bars installed in bathtubs must be measured to the top of the gripping surface just as is required by Section 609.4.1 for all other horizontal grab bars. The standard contains specifications for where vertical grab bars are to be measured only in one of six sections referenced in by Section 609.4.1, Section 604.5.1.2. Therefore, we are proposing a new requirement consistent with that section, to measure to the centerline of the vertical bar both in this section and in Section 609.4.1.

Please see our companion proposal to revise Section 609.4.

**Staff Note:** If this proposal passes, staff will correlate Figures 607.4.1(A) and (B), 607.4.2(A) and (B).

Committee Action: D 25-1-2

#### REPORT OF HEARING:

#### Modification (if any):

**Committee Reason:** Disapprove based on action to 06-80. The replacement proposal combines and addresses all the measurements for grab bars.

607.4-MAZZ.doc



<b>Report for 06-43- 2021</b>		
<b>Committee decision:</b> <i>D</i>	<b>Committee Vote at Meeting:</b> 25-1-2	<b>Committee Vote on Ballot:</b>
<b>REPORT OF HEARING:</b>		
Modification (if any):		
Committee Reason: Disapprove based on action to 06-80. The replacement proposal combines and addresses all the measurements for grab bars.		
<b>PUBLIC COMMENT- FIRST DRAFT:</b>		
Proponent:		
Desired Action:		
Modification:		
Reason:		
<b>Committee decision:</b> <i>AS/AM/D</i>	<b>Committee Vote at Meeting:</b>	<b>Committee Vote on Ballot:</b>
<b>REPORT OF HEARING – FIRST DRAFT</b>		
Modification (if any):		
Committee Reason:		
<b>PUBLIC COMMENT- SECOND DRAFT:</b>		
Proponent:		
Desired Action:		
Modification:		
Reason:		
<b>Committee decision:</b> <i>AS/AM/D</i>	<b>Committee Vote at Meeting:</b>	<b>Committee Vote on Ballot:</b>
<b>FINAL ACTION:</b>		
Modification (if any):		
Committee Reason:		

## 06-44 – 2021

### 607.4.1.2.1, 607.4.2.3

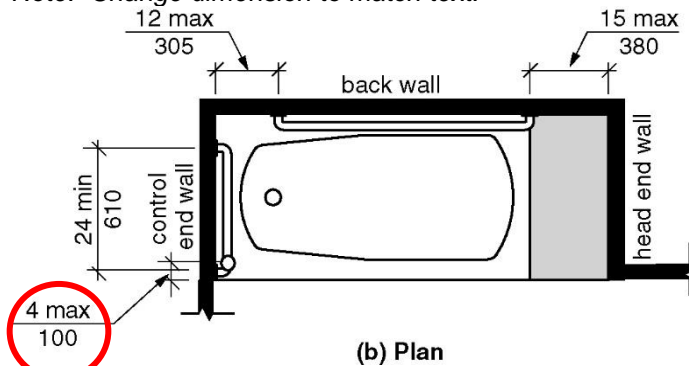
**Proponent:** Marsha Mazz, representing United Spinal Association

**Revise as follows:**

#### SECTION 607 BATHTUBS

**607.4.1.2.1 Horizontal grab bar.** A horizontal grab bar 24 inches (610 mm) minimum in length shall be provided on the control end wall ~~beginning near~~ 1 inch (25 mm) minimum and 4 inches (100 mm) maximum from the front edge of the bathtub and extending toward the inside corner of the bathtub.

*Note: Change dimension to match text.*

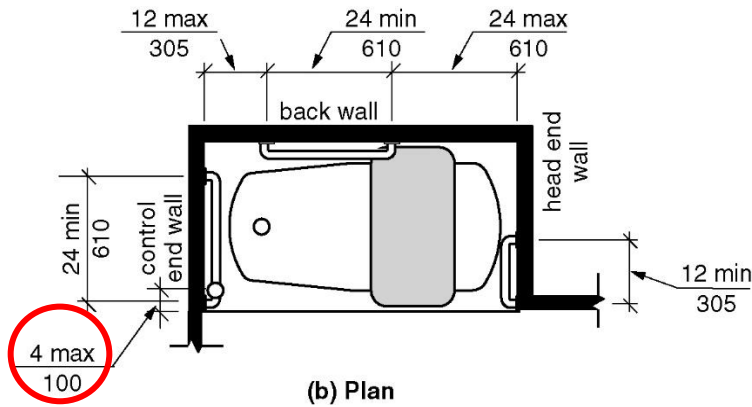


**FIGURE 607.4.1(B)**

#### GRAB BARS FOR BATHTUBS WITH SEAT AT HEAD END OF TUB - PLAN

**607.4.2.3 Head end wall.** A horizontal grab bar 12 inches (305 mm) minimum in length shall be provided on the head end wall ~~at~~ 1 inch (25 mm) minimum and 4 inches (100 mm) maximum from the front edge of the bathtub.

*Note: Change dimension to match text.*



**FIGURE 607.4.2(B)  
GRAB BARS FOR BATHTUBS WITH REMOVABLE SEATS - PLAN**

**REASON:** In Section 607.4.1.2.1, the word “near” does not provide enough guidance to avoid disagreements in the field. A specific dimension will help to avoid the potential that an installation will be rejected because it is not “near enough” to the front edge of the bath tub. We are proposing the same change to Section 607.4.2.3 for the sake of consistency and to provide some flexibility so that the grab bar does not interfere with a shower curtain.

Staff note: If this proposal passes, figures will be revises.

Committee Action: D 27-0-2

**REPORT OF HEARING:**

**Modification (if any):**

**Committee Reason:** Disapprove based on action to 06-80. The replacement proposal combines and addresses all the measurements for grab bars.

607.4.1.2.1-MAZZ.doc

<b>Report for 06-44- 2021</b>		
<b>Committee decision:</b> D	<b>Committee Vote at Meeting:</b> 27-0-2	<b>Committee Vote on Ballot:</b>
<b>REPORT OF HEARING:</b>		
Modification (if any):		
Committee Reason: Disapprove based on action to 06-80. The replacement proposal combines and addresses all the measurements for grab bars.		
<b>PUBLIC COMMENT- FIRST DRAFT:</b>		
Proponent:		
Desired Action:		
Modification:		
Reason:		
<b>Committee decision:</b> AS/AM/D	<b>Committee Vote at Meeting:</b>	<b>Committee Vote on Ballot:</b>
<b>REPORT OF HEARING – FIRST DRAFT</b>		
Modification (if any):		
Committee Reason:		
<b>PUBLIC COMMENT- SECOND DRAFT:</b>		
Proponent:		
Desired Action:		

<b>Report for 06-44- 2021</b>		
Modification:		
Reason:		
<b>Committee decision: AS/AM/D</b>	<b>Committee Vote at Meeting:</b>	<b>Committee Vote on Ballot:</b>
<b>FINAL ACTION:</b>		
Modification (if any):		
Committee Reason:		

## 06-45 – 2021

607.4.3(New), 607.4.3.1(New), 607.4.3.2(New), 607.4.3.2.1(New),  
607.4.3.2.2(New), Figures 607.4.3(A) and (B)(New)

**Proponent:** Doug Anderson, representing A117.1 Accessible Bathing Task Group

**Add new text as follows:**

### SECTION 607 BATHTUBS

**607.4.3 Bathtubs with fixed folding in-tub seats.** For bathtubs with fixed folding in-tub seats, grab bars complying with Section 607.4.3 shall be provided.

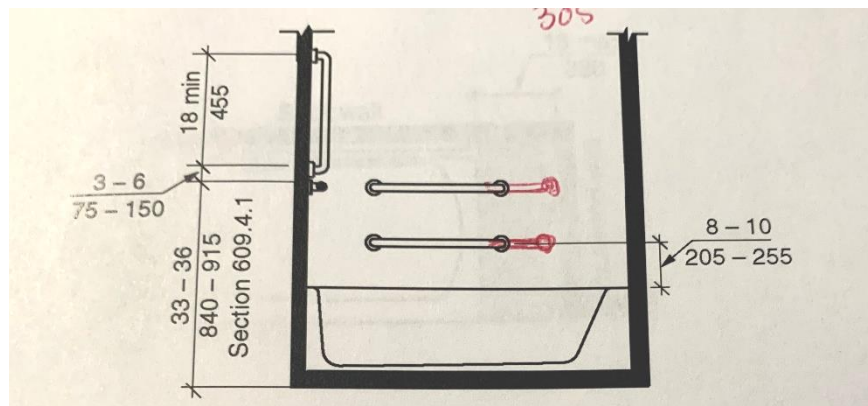
**607.4.3.1 Back wall.** Two horizontal grab bars shall be provided on the back wall, one complying with Section 609.4 and the other located 8 inches (205 mm) minimum and 10 inches (255 mm) maximum above the rim of the bathtub. Each grab bar shall be 30 inches (610mm) minimum in length, located 18 inches (610 mm) maximum from the head end wall and extend to 12 inches (305 mm) maximum from the control end wall.

**Control end wall.** Control end wall grab bars shall comply with Section 607.4.3.2.

**Exception:** An L-shaped continuous grab bar of equivalent dimensions and positioning shall be permitted to serve the function of separate vertical and horizontal grab bars.

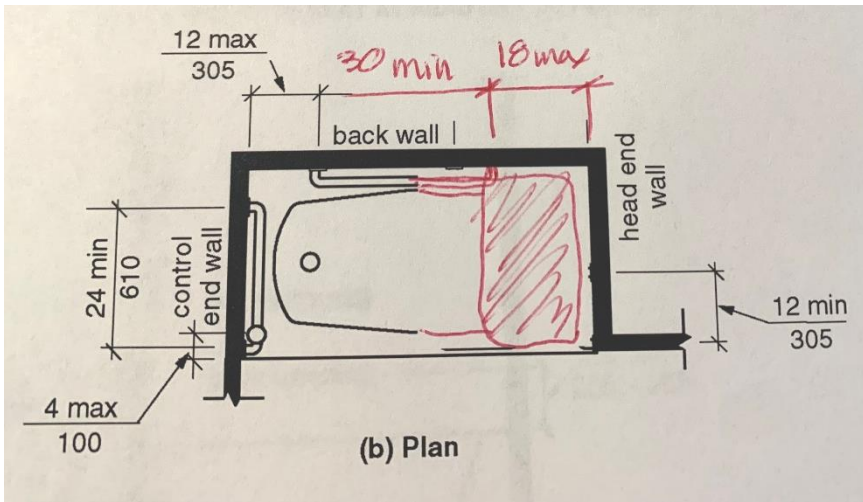
**607.4.3.2.1 Horizontal grab bar.** A horizontal grab bar 24 inches (610 mm) minimum in length shall be provided on the control end wall beginning near the front edge of the bathtub and extending toward the inside corner of the bathtub.

**607.4.3.2.2 Vertical grab bar.** A vertical grab bar 18 inches (455 mm) minimum in length shall be provided on the control end wall 3 inches (75 mm) minimum and 6 inches (150 mm) maximum above the horizontal grab bar, and 4 inches (100 mm) maximum inward from the front edge of the bathtub.



**FIGURE 607.4.3(A)**

**GRAB BARS FOR BATHTUBS WITH FIXED FOLDING IN-TUB SEATS – ELEVATION**



**FIGURE 607.4.3(B)**  
**GRAB BARS FOR BATHTUBS WITH FIXED FOLDING IN-TUB SEATS –PLAN**

**REASON:** Grab bars need to be closer to the head wall when the in-tub seats is mounted on the headwall. The photos are to illustrate what this proposal is talking about.



**Staff Note:** This proposal is from the A117.1 Accessible Bathing Task Group. Proposals 06-41, 06-42, 06-45, 06-50 and 06-81 are all related to bathtubs with a fixed folding in-tub seat.

## 06-45 – 2021 Replacement

607.2, Figure 607.2(B), Figure 607.2(C), 607.3, 607.4.1, Figure 607.4.1(A), Figure 607.4.1(B), 607.4.3(New), 607.4.3.1(New), 607.4.3.2.2(New), Figure 607.4.3(A) (New), Figure 607.4.3(B) (New), 607.5, 607.6, 607.6.1(New), 607.6.2(New), Figure 607.6.2(New), 609.4.1, 610.2, 610.2.1(New), 610.2.2(New), Figure 610.2(B), 610.2.3(New), Figure 610.2.3(New)

**Proponent:** Doug Anderson, representing A117.1 Accessible Bathing Task Group

Note: Proposals 06-41, 06-42, 06-45, 06-50 and 06-81 are all related to bathtubs. Modifications to 06-41, 06-42 and 06-45 will replace the 5 proposal (separated by section) with 3 proposals (separated to one for each type of bathtub seat configuration).

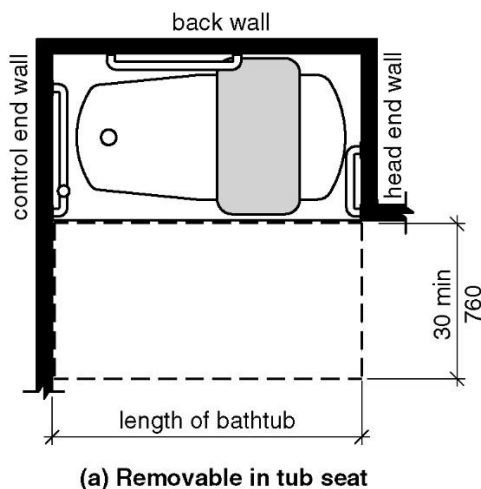
**Replace with the following:**

### SECTION 607 BATHTUBS

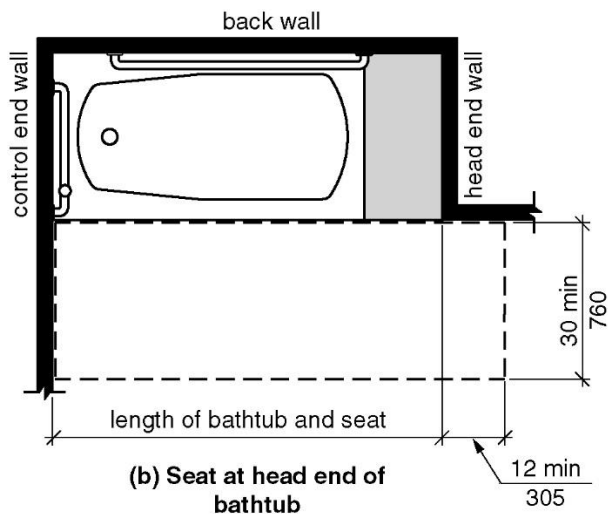
**607.1 General.** Bathtubs shall comply with Section 607.

**607.2 Clearance.** A clearance in front of bathtubs extending the length of the bathtub and 30 inches (760 mm) minimum in depth shall be provided. Where a permanent seat transfer platform or folding in-tub seat is provided at the head end of the bathtub, the clearance shall extend 12 inches (305 mm) minimum beyond the wall at the head end of the bathtub.

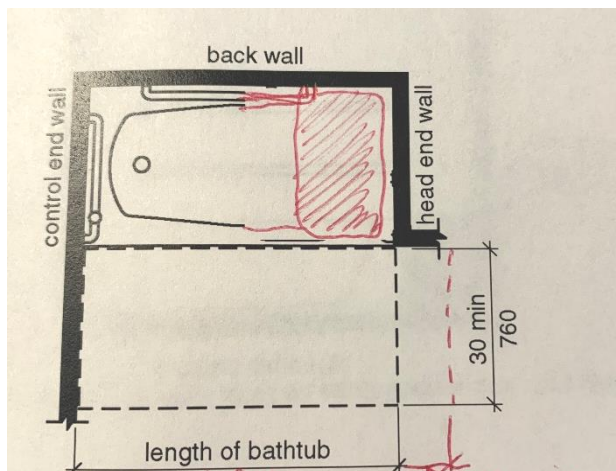
**Exception:** In an existing bathtub where bathroom is not reconfigured and a folding in-tub seat is installed, the additional the 12 inches (305 mm) transfer clearance beyond the wall at the head end of the bathtub is not required.



**FIGURE 607.2(A)  
CLEARANCE FOR BATHTUBS WITH REMOVABLE IN TUB SEATS**



**FIGURE 607.2(B)**  
**CLEARANCE FOR BATHTUBS WITH SEAT TRANSFER PLATFORM AT HEAD END OF TUB**



**FIGURE 607.2(C)**  
**CLEARANCE FOR BATHTUBS WITH FOLDING IN-TUB SEAT AT HEAD END OF TUB**

**607.3 Seat.** A permanent seat at the head end of the bathtub folding in-tub seat at the head end of the tub or a removable in-tub seat shall be provided. Seats and transfer platforms shall comply with Section 610.

**607.4 Grab bars.** Grab bars shall comply with Section 609 and shall be provided in accordance with Section 607.4.1 or 607.4.2.

**Exception:** Grab bars shall not be required to be installed in a bathing facility for a single occupant accessed only through a private office and not for common use or public use, provided reinforcement has been installed in walls and located so as to permit the installation of grab bars complying with Section 607.4.



**607.4.1 Bathtubs with permanent seats transfer platforms.** For bathtubs with permanent seats transfer platforms, grab bars complying with Section 607.4.1 shall be provided.

**Figure 607.4.1(A) Grab Bars for Bathtubs with Seat-Transfer Platforms at Head End of Tub – Elevation**

**Figure 607.4.1(B) Grab Bars for Bathtubs with Seat-Transfer Platforms at Head End of Tub – Plan**

**607.4.1.1 Back wall.** Two horizontal grab bars shall be provided on the back wall, one complying with Section 609.4 and the other located 8 inches (205 mm) minimum and 10 inches (255 mm) maximum above the rim of the bathtub. Each grab bar shall be located 15 inches (380 mm) maximum from the head end wall and extend to 12 inches (305 mm) maximum from the control end wall.

**607.4.1.2 Control end wall.** Control end wall grab bars shall comply with Section 607.4.1.2.

**Exception:** An L-shaped continuous grab bar of equivalent dimensions and positioning shall be permitted to serve the function of separate vertical and horizontal grab bars.

**607.4.1.2.1 Horizontal grab bar.** A horizontal grab bar 24 inches (610 mm) minimum in length shall be provided on the control end wall beginning near the front edge of the bathtub and extending toward the inside corner of the bathtub.

**607.4.1.2.2 Vertical grab bar.** A vertical grab bar 18 inches (455 mm) minimum in length shall be provided on the control end wall 3 inches (75 mm) minimum and 6 inches (150 mm) maximum above the horizontal grab bar, and 4 inches (100 mm) maximum inward from the front edge of the bathtub.

**607.4.2 Bathtubs with removable in-tub seats.** For bathtubs with removable in-tub seats, grab bars complying with Section 607.4.2 shall be provided.

**Figure 607.4.2(A) Grab Bars for Bathtubs with Removable In-tub Seats – Elevation**

**Figure 607.4.2(B) Grab Bars for Bathtubs with Removable In-tub Seats - Plan**

**607.4.2.1 Back wall.** Two horizontal grab bars shall be provided on the back wall, one complying with Section 609.4 and the other located 8 inches (205 mm) minimum and 10 inches (255 mm) maximum above the rim of the bathtub. Each grab bar shall be 24 inches (610 mm) minimum in length, located 24 inches (610 mm) maximum from the head end wall and extend to 12 inches (305 mm) maximum from the control end wall.

**607.4.2.2 Control end wall.** Control end wall grab bars shall comply with Section 607.4.1.2.

**607.4.2.3 Head end wall.** A horizontal grab bar 12 inches (305 mm) minimum in length shall be provided on the head end wall at the front edge of the bathtub.

**607.4.3 Bathtubs with folding in-tub seats.** For bathtubs with folding in-tub seats at the head end of the tub, grab bars complying with Section 607.4.3 shall be provided.

**607.4.3.1 Back wall.** Two horizontal grab bars shall be provided on the back wall, one complying with Section 609.4 and the other located 8 inches (205 mm) minimum and 10

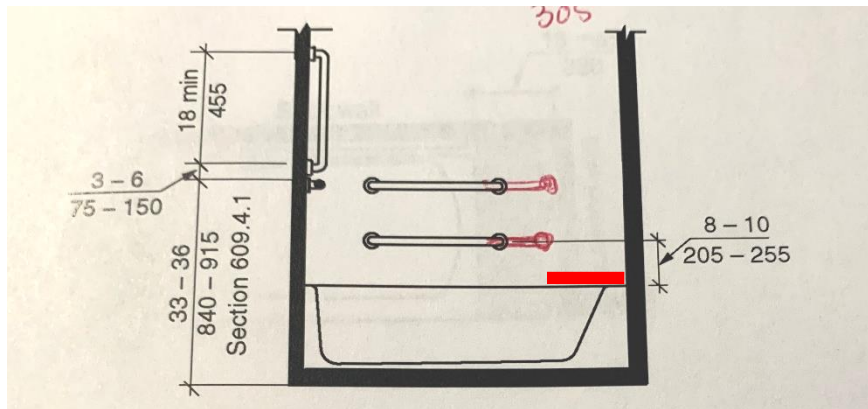
inches (255 mm) maximum above the rim of the bathtub. Each grab bar shall be 30 inches (610mm) minimum in length, located 18 inches (610 mm) maximum from the head end wall and extend to 12 inches (305 mm) maximum from the control end wall.

**Control end wall.** Control end wall grab bars shall comply with Section 607.4.3.2.

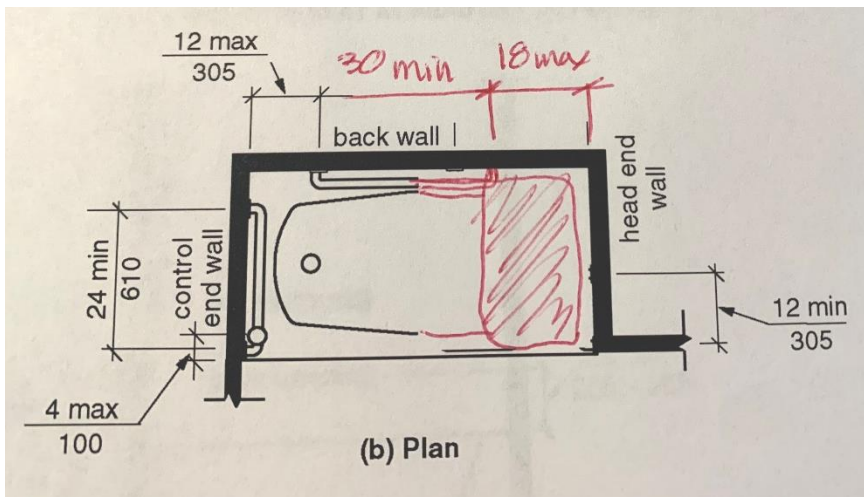
**Exception:** An L-shaped continuous grab bar of equivalent dimensions and positioning shall be permitted to serve the function of separate vertical and horizontal grab bars.

**607.4.3.2.1 Horizontal grab bar.** A horizontal grab bar 24 inches (610 mm) minimum in length shall be provided on the control end wall beginning near the front edge of the bathtub and extending toward the inside corner of the bathtub.

**607.4.3.2.2 Vertical grab bar.** A vertical grab bar 18 inches (455 mm) minimum in length shall be provided on the control end wall 3 inches (75 mm) minimum and 6 inches (150 mm) maximum above the horizontal grab bar, and 4 inches (100 mm) maximum inward from the front edge of the bathtub.



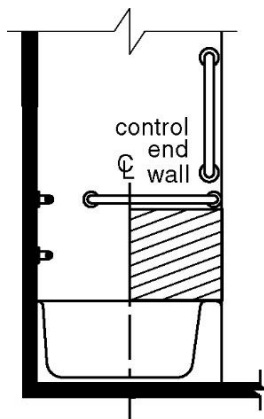
**FIGURE 607.4.3(A)**  
**GRAB BARS FOR BATHTUBS WITH FOLDING IN-TUB SEATS – ELEVATION**



**FIGURE 607.4.3(B)**  
**GRAB BARS FOR BATHTUBS WITH FOLDING IN-TUB SEATS –PLAN**

(Note: The intent is to be coordinated with the modification for controls for all tubs.)

**607.5 Controls.** The operable parts of the on/off water floor, temperature and diverter controls ~~Controls, other than drain stoppers,~~ shall be provided on an end wall, located between the bathtub rim and grab bar, and between the open side of the bathtub and the centerline of the width of the bathtub. Such Controls shall comply with Section 309.4.



**FIGURE 607.5**  
**LOCATION OF BATHTUB CONTROLS**

(Note: The intent is to be coordinated with the modification for hand showers for all tubs.)

**607.6 Hand shower.** A hand shower with a hose 59 inches (1500 mm) minimum in length, that can be used as both a fixed shower head and as a hand shower, shall be provided. The hand shower shall have ~~a control with~~ a nonpositive shut-off feature. A fixed shower head, in addition to the hand shower shall be permitted.

**Exception:** In other than Accessible units and Type A units, a fixed shower head located 48 inches (1220 mm) maximum above the shower floor shall be permitted in lieu of a hand shower.

A mount to hold the hand shower shall be provided and located in accordance with Section 607.6.1 or 607.6.2 as applicable. Where provided, an adjustable height hand shower mounted on a vertical bar shall be installed so as to not obstruct the use of grab bars.

**Exception:** The mount to hold the hand shower shall be permitted to be located on a vertical bar provided that the mount is adjustable in height and the mount can be located within the area specified for the fixed mount.

**607.6.1 Bathtubs with removable in-tub seats.** For a bathtub with a moveable in-tub seat, the mount to hold the hand shower shall be located in accordance with to the following:

1. At a height of 38 inches (965 mm) minimum and 48 inches (1220 mm) maximum above the shower floor.

2. Located on the control wall opposite the seat and located within 15 inches (380 mm) maximum from the centerline of the seat.

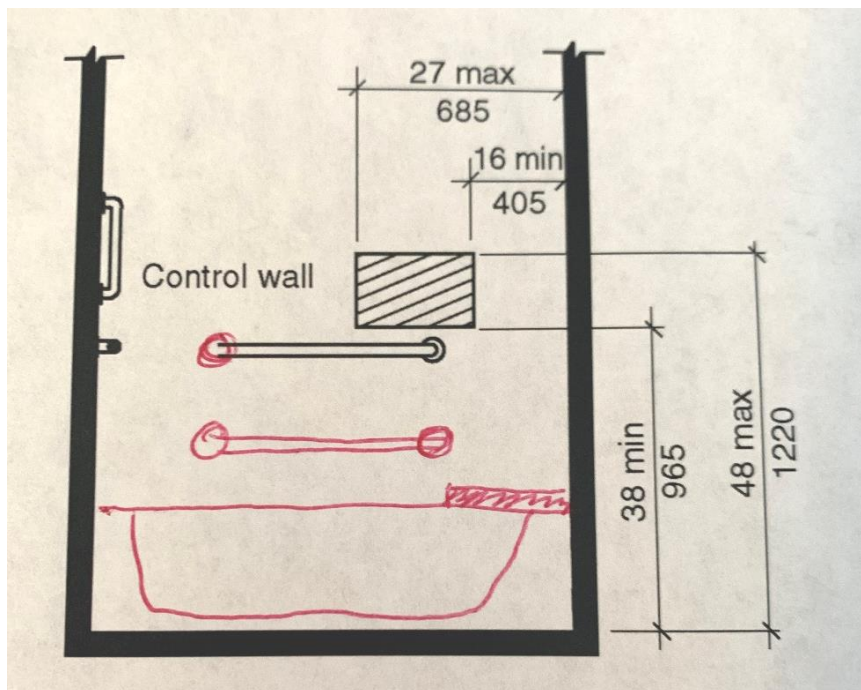
Exception: The mount to hold the hand shower shall be permitted to be located on a vertical bar provided that the mount is adjustable in height and can be located within the area specified for the fixed mount.

**607.6.2 Bathtubs with folding seats.** For a bathtub with a folding seat, the mount to hold the hand shower shall be located in accordance with to the following:

1. At a height of 38 inches (965 mm) minimum and 48 inches (1220 mm) maximum above the shower floor.

2. Located on the back wall 16 inches (405 mm) minimum and 27 inches (685 mm) maximum from the wall behind the seat.

Exception: The mount to hold the hand shower shall be permitted to be located on a vertical bar provided that the mount is adjustable in height and can be located within the area specified for the fixed mount.



**FIGURE 607.6.2**  
**LOCATION OF MOUNT FOR BATHTUB WITH FOLDING SEAT**

**607.7 Bathtub enclosures.** Enclosures for bathtubs shall not obstruct controls, faucets, shower and spray units or obstruct transfer from wheelchairs onto bathtub seats or into bathtubs. Enclosures on bathtubs shall not have tracks installed on the rim of the bathtub.

**607.8 Water temperature.** Bathtubs shall deliver water that is 120°F (49°C) maximum.

## SECTION 609 GRAB BARS

**609.1 General.** Grab bars in toilet or bathing facilities shall comply with Section 609.

**609.2 Cross section.** Grab bars shall have a cross section complying with Section 609.2.1 or 609.2.2.

Figure 609.2 Size of Grab Bars

**609.2.1 Circular cross section.** Grab bars with a circular cross section shall have an outside diameter of 1<sup>1</sup>/<sub>4</sub> inch (32 mm) minimum and 2 inches (51 mm) maximum.

**609.2.2 Noncircular cross section.** Grab bars with a noncircular cross section shall have a cross section dimension of 2 inches (51 mm) maximum, and a perimeter dimension of 4 inches (100 mm) minimum and 4.8 inches (120 mm) maximum.

**609.3 Spacing.** The space between the wall and the grab bar shall be 1<sup>1</sup>/<sub>2</sub> inches (38 mm). The space between the grab bar and projecting objects below and at the ends of the grab bar shall be 1<sup>1</sup>/<sub>2</sub> inches (38 mm) minimum. The space between the grab bar and projecting objects above the grab bar shall be 12 inches (305 mm) minimum.

### Exceptions:

1. The space between the grab bars and shower controls, shower fittings, and other grab bars above the grab bar shall be permitted to be 1<sup>1</sup>/<sub>2</sub> inches (38 mm) minimum.
2. Recessed dispensers projecting from the wall 1/4 inch (6.4 mm) maximum measured from the face of the dispenser and complying with Section 604.7 shall be permitted within the 12-inch (305 mm) space above and the 1<sup>1</sup>/<sub>2</sub>-inch (38 mm) spaces below and at the ends of the grab bar.

Figure 609.3 Spacing of Grab Bars

### 609.4 Position of grab bars.

**609.4.1 General.** Grab bars shall be installed in a horizontal position, 33 inches (840 mm) minimum and 36 inches (915 mm) maximum above the floor measured to the top of the gripping surface or shall be installed as required by Items 1 through 3.

1. The lower grab bar on the back wall of a bathtub shall comply with Section 607.4.1.1, ~~or~~ 607.4.2.1 or 607.4.3.1.
2. Vertical grab bars shall comply with Sections 604.5.1.2, 607.4.1.2.2, 607.4.2.2, 607.4.3.2.2 and 608.3.1.2.
3. Grab bars at water closets primarily for children's use shall comply with Section 609.4.2.

**609.4.2 Position of children's grab bars.** At water closets primarily for children's use complying with Section 604.11, grab bars shall be installed in a horizontal position 18 inches (455 mm) minimum and 27 inches (685 mm) maximum above the floor measured to the top of the gripping surface. A vertical grab bar shall be mounted with the bottom of the bar located between 21 inches (535 mm) minimum and 30 inches (760 mm) maximum above the floor and with the centerline of the bar located between 34 inches (865 mm) minimum and 36 inches (915 mm) maximum from the rear wall.

Figure 609.4.2(A) Positions of Children's Grab Bars - Side-wall View

Figure 609.4.2(B) Positions of Children's Grab Bars - Rear-wall View

**609.5 Surface hazards.** Grab bars and any wall or other surfaces adjacent to grab bars shall be free of sharp or abrasive elements. Edges shall be rounded.

**609.6 Fittings.** Grab bars shall not rotate within their fittings.

**609.7 Installation and configuration.** Grab bars shall be installed in any manner that provides a gripping surface at the locations specified in this standard and does not obstruct the clear floor space. Horizontal and vertical grab bars shall be permitted to be separate bars, a single piece bar, or combination thereof.

**609.8 Structural strength.** Allowable stresses shall not be exceeded for materials used where a vertical or horizontal force of 250 pounds (1112 N) is applied at any point on the grab bar, fastener mounting device, or supporting structure.

## **SECTION 610 SEATS**

**610.1 General.** Seats in bathtubs and shower compartments shall comply with Section 610.

**610.2 Bathtub seats.** The height of bathtub seats shall be 17 inches (430 mm) minimum and 19 inches (485 mm) maximum above the bathroom floor, measured to the top of the seat. Bathtub seats shall be rectangular in shape.

**610.2.1 Removable in-tub seats.** Removable in-tub seats shall be 15 inches (380 mm) minimum and 16 inches (405 mm) maximum in depth. Removable in-tub seats shall be capable of secure placement.

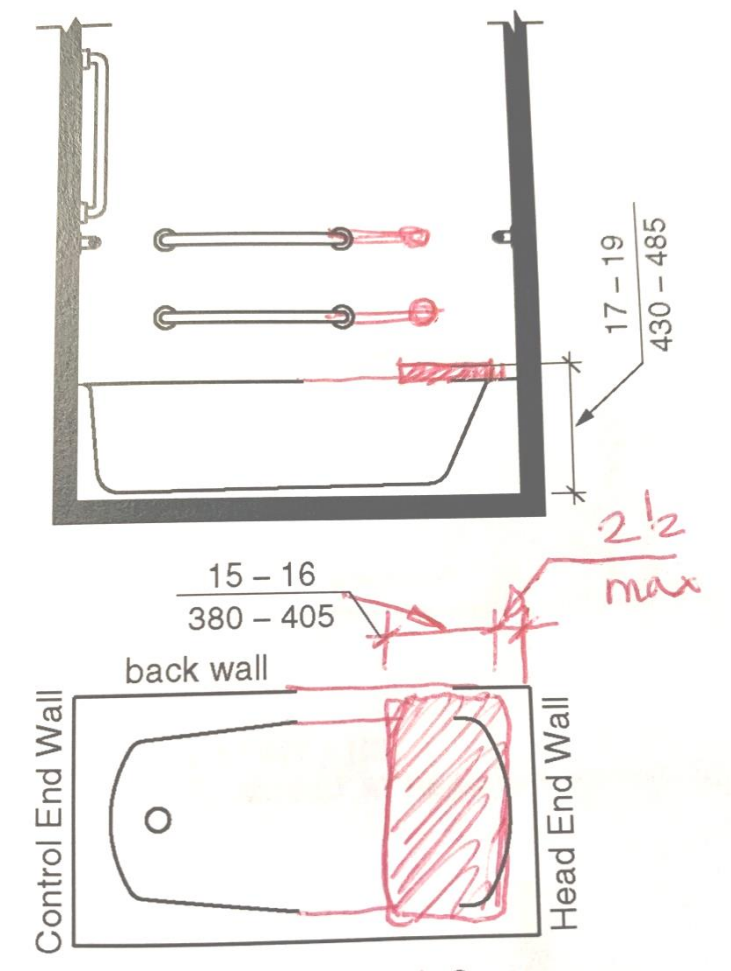
### **FIGURE ~~610.2(A)~~ 610.2.1 BATHTUB SEATS REMOVABLE IN-TUB SEATS**

**610.2.2 Bathtubs with transfer platforms.** ~~Permanent seats~~ Transfer platforms shall be 15 inches (380 mm) minimum in depth and shall extend from the back wall to or beyond the outer edge of the bathtub. ~~Permanent seats~~ Transfer platforms shall be positioned at the head end of the bathtub.

### **FIGURE 610.2(B) 610.2.2 BATHTUB SEATS SEAT TRANSFER PLATFORM PROVIDED AT HEAD END OF TUB**

**610.2.3 Folding in-tub seats.** Folding in-tub seats shall be mounted on the head wall. The rear edge of a seat shall be 2-1/2 inches (64 mm) maximum and the seat shall be 15 inches (380 mm) minimum and 16 inches (405 mm) maximum in depth. The side edge of the seat shall be 1-1/2 inches (38 mm) maximum from the back wall.





**FIGURE 610.2.3**  
**BATHTUB SEATS**  
**FOLDING IN-TUB SEAT PROVIDED AT HEAD END OF TUB**

**610.3 Shower compartment seats.** The height of shower compartment seats shall be 17 inches (430 mm) minimum and 19 inches (485 mm) maximum above the bathroom floor, measured to the top of the seat. In transfer-type and alternate roll-in-type showers, the seat shall extend along the seat wall to a point within 3 inches (75 mm) of the compartment entry. In standard roll-in-type showers, the seat shall extend from the control wall to a point within 3 inches (75 mm) of the compartment entry. Seats shall comply with Section 610.3.1 or 610.3.2.

**610.3.1 Rectangular seats.** The rear edge of a rectangular seat shall be 2½ inches (64 mm) maximum and the front edge 15 inches (380 mm) minimum and 16 inches (405 mm) maximum from the seat wall. The side edge of the seat shall be 1½ inches (38 mm) maximum

from the back wall of a transfer-type shower and 1½ inches (38 mm) maximum from the control wall of a roll-in-type shower.

Figure 610.3.1 Rectangular Shower Compartment Seats

**610.3.2 L-shaped seats.** The rear edge of an L-shaped seat shall be 2½ inches (64 mm) maximum and the front edge 15 inches (380 mm) minimum and 16 inches (405 mm) maximum from the seat wall. The rear edge of the “L” portion of the seat shall be 1½ inches (38 mm) maximum from the wall and the front edge shall be 14 inches (355 mm) minimum and 15 inches (380 mm) maximum from the wall. The end of the “L” shall be 22 inches (560 mm) minimum and 23 inches (585 mm) maximum from the main seat wall.

Figure 610.3.2 L-shaped Shower Compartment Seats

**610.4 Structural strength.** Allowable stresses shall not be exceeded for materials used where a vertical or horizontal force of 250 pounds (1112 N) is applied at any point on the seat, fastener mounting device, or supporting structure.

**Reason:**

**Purpose:** Allow for foldable seat that is attached at the head end of tub. By being mounted this reduces the chance of the seat slipping and makes sure that the seat does not disappear from the room. This also allow for the person to put down the seat themselves rather than needed staff to come and install the portable seat. This should improve safety when using the seat. This also provides a back rest for a person using the tub. Some of the task group felt that providing for a back rest and having the seat overlap the tub so that it could be used for showering was an improvement for accessibility, even without being able to adjust the water while showering.

**Steps. –**

For consistency with terminology for showers, separate fixed seats/transfer platforms and folding seats.

Clearance to have similar transfer requirements as transfer shower for lining up back of seat with back of chair.

Exception - For existing bathrooms allow for this installation without increasing size of room.

Set grab bar criteria – same as other current options at front. Extend back wall grab bars to be within reach of seat.

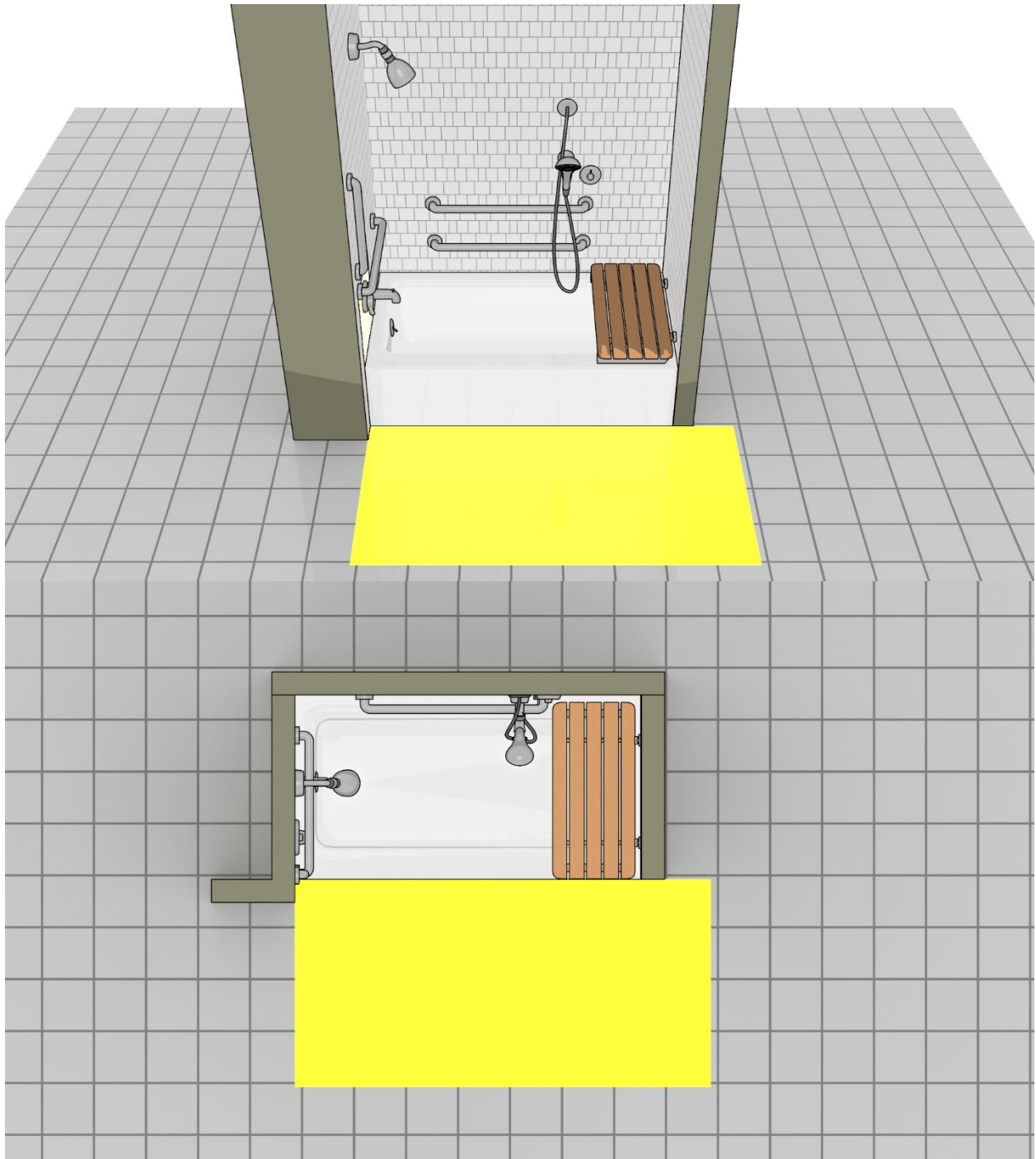
Set up criteria for turning on water and temperature from outside tub.

Set up area to reach shower hand held shower mount. Locate in front folding seat since you cannot reach the control wall.

Set criteria for seat similar to shower requirements.

There were many discussions during the task group calls about this option not allowing for control of the water temperature. This would allow for the ability to turn the shower head on and off from the seat. Water use restrictions do not allow for two separate sets of controls. Since this is a bathtub, if you move the controls to the back wall you then have to consider the spout being in front of the seat and that reaching over the tub would be a safety issue for persons trying to turn on the water from outside the tub.





---

Committee Action: Approval As Modified 24-3-0

**REPORT OF HEARING:**

**Modification (if any):** Proposals 06-41, 06-42, 06-45, 06-50 and 06-81 are all related to bathtubs. Modifications to 06-41, 06-42 and 06-45 will replace the 5 proposal (separated by section) with 3 proposals (separated to one for each type of bathtub seat configuration).

See the replacement proposal above to see the changes in context. The Report of Hearing will only indicate the changes to text and titles of figures. Revisions to the figures is the responsibility of the Editorial committee. It was noted that the task group did not have sufficient time to fully update the graphics submitted.

This additional modification was proposed to the exception in Section 607.2. This was made part of the replacement proposal.

**607.2 Clearance.** A clearance in front of bathtubs extending the length of the bathtub and 30 inches (760 mm) minimum in depth shall be provided. Where a transfer platform or folding in-tub seat is provided at the head end of the bathtub, the clearance shall extend 12 inches (305 mm) minimum beyond the wall at the head end of the bathtub.

**Exception:** In an existing bathtub where bathroom is not reconfigured and a folding in-tub seat is installed, the additional ~~the~~ 12 inches (305 mm) transfer clearance beyond the wall at the head end of the bathtub is not required if it would result in a reconfiguration of the space.

The full modification is as follows:

**607.2 Clearance.** A clearance in front of bathtubs extending the length of the bathtub and 30 inches (760 mm) minimum in depth shall be provided. Where a permanent seat transfer platform or folding in-tub seat is provided at the head end of the bathtub, the clearance shall extend 12 inches (305 mm) minimum beyond the wall at the head end of the bathtub.

**Exception:** In an existing bathtub where bathroom is not reconfigured and a folding in-tub seat is installed, the additional 12 inches (305 mm) transfer clearance beyond the wall at the head end of the bathtub is not required if it would result in a reconfiguration of the space.

#### **FIGURE 607.2(B) CLEARANCE FOR BATHTUBS WITH SEAT TRANSFER PLATFORM AT HEAD END OF TUB**

#### **FIGURE 607.2(C) CLEARANCE FOR BATHTUBS WITH FOLDING IN-TUB SEAT AT HEAD END OF TUB**

**607.3 Seat.** A ~~permanent seat at the head end of the bathtub~~ folding in-tub seat at the head end of the tub or a removable in-tub seat shall be provided. Seats and transfer platforms shall comply with Section 610.

**607.4 Grab bars.** Grab bars shall comply with Section 609 and shall be provided in accordance with Section 607.4.1 or 607.4.2.

**Exception:** Grab bars shall not be required to be installed in a bathing facility for a single occupant accessed only through a private office and not for common use or public use, provided reinforcement has been installed in walls and located so as to permit the installation of grab bars complying with Section 607.4.

**607.4.1 Bathtubs with permanent seats transfer platforms.** For bathtubs with permanent seats transfer platforms, grab bars complying with Section 607.4.1 shall be provided.

**Figure 607.4.1(A) Grab Bars for Bathtubs with Seat-Transfer Platforms at Head End of Tub – Elevation**

**Figure 607.4.1(B) Grab Bars for Bathtubs with Seat-Transfer Platforms at Head End of Tub – Plan**

**607.4.2 Bathtubs with removable in-tub seats.** For bathtubs with removable in-tub seats, grab bars complying with Section 607.4.2 shall be provided.

**Figure 607.4.2(A) Grab Bars for Bathtubs with Removable In-tub Seats – Elevation**

**Figure 607.4.2(B) Grab Bars for Bathtubs with Removable In-tub Seats - Plan**

**607.4.3 Bathtubs with folding in-tub seats.** For bathtubs with folding in-tub seats at the head end of the tub, grab bars complying with Section 607.4.3 shall be provided.

**607.4.3.1 Back wall.** Two horizontal grab bars shall be provided on the back wall, one complying with Section 609.4 and the other located 8 inches (205 mm) minimum and 10 inches (255 mm) maximum above the rim of the bathtub. Each grab bar shall be 30 inches (610mm) minimum in length, located 18 inches (610 mm) maximum from the head end wall and extend to 12 inches (305 mm) maximum from the control end wall.

**Control end wall.** Control end wall grab bars shall comply with Section 607.4.3.2.

**Exception:** An L-shaped continuous grab bar of equivalent dimensions and positioning shall be permitted to serve the function of separate vertical and horizontal grab bars.

**607.4.3.2.1 Horizontal grab bar.** A horizontal grab bar 24 inches (610 mm) minimum in length shall be provided on the control end wall beginning near the front edge of the bathtub and extending toward the inside corner of the bathtub.

**607.4.3.2.2 Vertical grab bar.** A vertical grab bar 18 inches (455 mm) minimum in length shall be provided on the control end wall 3 inches (75 mm) minimum and 6 inches (150 mm) maximum above the horizontal grab bar, and 4 inches (100 mm) maximum inward from the front edge of the bathtub.

**FIGURE 607.4.3(A) GRAB BARS FOR BATHTUBS WITH FOLDING IN-TUB SEATS – ELEVATION**

**FIGURE 607.4.3(B) GRAB BARS FOR BATHTUBS WITH FOLDING IN-TUB SEATS – PLAN**

(Note: The intent is to be coordinated with the modification for controls for all tubs.)

**607.5 Controls.** The operable parts of the on/off water floor, temperature and diverter controls ~~Controls, other than drain stoppers,~~ shall be provided on an end wall, located between the bathtub rim and grab bar, and between the open side of the bathtub and the centerline of the width of the bathtub. Such Controls shall comply with Section 309.4.

(Note: The intent is to be coordinated with the modification for hand showers for all tubs.)

**607.6 Hand shower.** A hand shower with a hose 59 inches (1500 mm) minimum in length, that can be used as both a fixed shower head and as a hand shower, shall be provided. The hand shower shall have ~~a control with~~ a nonpositive shut-off feature. A fixed shower head, in addition to the hand shower shall be permitted.

**Exception:** In other than Accessible units and Type A units, a fixed shower head located 48 inches (1220 mm) maximum above the shower floor shall be permitted in lieu of a hand shower.

A mount to hold the hand shower shall be provided and located in accordance with Section 607.6.1 or 607.6.2 as applicable. ~~Where provided, an adjustable height hand shower mounted on a vertical bar shall be installed so as to not obstruct the use of grab bars.~~

**Exception:** The mount to hold the hand shower shall be permitted to be located on a vertical bar provided that the mount is adjustable in height and the mount can be located within the area specified for the fixed mount.

**607.6.1 Bathtubs with removable in-tub seats.** For a bathtub with a moveable in-tub seat, the mount to hold the hand shower shall be located in accordance with to the following:

1. At a height of 38 inches (965 mm) minimum and 48 inches (1220 mm) maximum above the tub floor.
2. Located on the control wall opposite the seat and located within 15 inches (380 mm) maximum from the centerline of the seat.

**Exception:** The mount to hold the hand shower shall be permitted to be located on a vertical bar provided that the mount is adjustable in height and can be located within the area specified for the fixed mount.

**607.6.2 Bathtubs with folding seats.** For a bathtub with a folding seat, the mount to hold the hand shower shall be located in accordance with to the following:

1. At a height of 38 inches (965 mm) minimum and 48 inches (1220 mm) maximum above the tub floor.
2. Located on the back wall 16 inches (405 mm) minimum and 27 inches (685 mm) maximum from the wall behind the seat.

**Exception:** The mount to hold the hand shower shall be permitted to be located on a vertical bar provided that the mount is adjustable in height and can be located within the area specified for the fixed mount.

#### **FIGURE 607.6.2 LOCATION OF MOUNT FOR BATHTUB WITH FOLDING SEAT**

**609.4.1 General.** Grab bars shall be installed in a horizontal position, 33 inches (840 mm) minimum and 36 inches (915 mm) maximum above the floor measured to the top of the gripping surface or shall be installed as required by Items 1 through 3.

1. The lower grab bar on the back wall of a bathtub shall comply with Section 607.4.1.1, ~~or~~ 607.4.2.1 or 607.4.3.1.
2. Vertical grab bars shall comply with Sections 604.5.1.2, 607.4.1.2.2, 607.4.2.2, 607.4.3.2.2 and 608.3.1.2.
3. Grab bars at water closets primarily for children's use shall comply with Section 609.4.2.

**610.2 Bathtub seats.** The height of bathtub seats shall be 17 inches (430 mm) minimum and 19 inches (485 mm) maximum above the bathroom floor, measured to the top of the seat. Bathtub seats shall be rectangular in shape.

**610.2.1 Removable in-tub seats.** Removable in-tub seats shall be 15 inches (380 mm) minimum and 16 inches (405 mm) maximum in depth. Removable in-tub seats shall be capable of secure placement.

**FIGURE ~~610.2(A)~~ 610.2.1 BATHTUB SEATS REMOVABLE IN-TUB SEATS**

**610.2.2 Bathtubs with transfer platforms.** ~~Permanent seats~~ Transfer platforms shall be 15 inches (380 mm) minimum in depth and shall extend from the back wall to or beyond the outer edge of the bathtub. ~~Permanent seats~~ Transfer platforms shall be positioned at the head end of the bathtub.

**FIGURE ~~610.2(B)~~ 610.2.2 BATHTUB SEATS SEAT TRANSFER PLATFORM PROVIDED AT HEAD END OF TUB**

**610.2.3 Folding in-tub seats.** Folding in-tub seats shall be mounted on the head wall. The rear edge of a seat shall be 2-1/2 inches (64 mm) maximum and the seat shall be 15 inches (380 mm) minimum and 16 inches (405 mm) maximum in depth. The side edge of the seat shall be 1-1/2 inches (38 mm) maximum from the back wall.

**FIGURE 610.2.3 BATHTUB SEATS FOLDING IN-TUB SEAT PROVIDED AT HEAD END OF TUB**

**Committee Reason:** The option for a folding seat at the head end of a tub provides some definite advantages over the removeable seat. By being mounted this reduces the chance of the seat slipping and makes sure that the seat does not disappear from the room. This also allow for the person to put down the seat themselves rather than needed staff to come and install the portable seat. This also provides a back rest for a person using the tub. Some of the task group felt that providing for a back rest and having the seat overlap the tub so that it could be used for showering was an improvement for accessibility, even without being able to adjust the water while showering. The proposal does put the hand shower mount within reach of the seat. Since

there was some concern about the limited leg space with the removeable seat close to the control wall, this option also provides space for someone that needed more leg room. There was discussion about the scoping for the three options for bathtubs. The task group stated that the intent was for no change to the scoping and to allow for any of the three options.

607.4.3-ANDERSON.doc

Report for 06-45- 2021		
Committee decision: AM	Committee Vote at Meeting: 24-3-0	Committee Vote on Ballot:
<p><b>REPORT OF HEARING:</b> Modification (if any): Proposals 06-41, 06-42, 06-45, 06-50 and 06-81 are all related to bathtubs. Modifications to 06-41, 06-42 and 06-45 will replace the 5 proposal (separated by section) with 3 proposals (separated to one for each type of bathtub seat configuration).</p> <p>See the replacement proposal above to see the changes in context. The Report of Hearing will only indicate the changes to text and titles of figures. Revisions to the figures is the responsibility of the Editorial committee. It was noted that the task group did not have sufficient time to fully update the graphics submitted.</p> <p><b>607.2 Clearance.</b> A clearance in front of bathtubs extending the length of the bathtub and 30 inches (760 mm) minimum in depth shall be provided. Where a <u>permanent seat transfer platform or folding in-tub seat</u> is provided at the head end of the bathtub, the clearance shall extend 12 inches (305 mm) minimum beyond the wall at the head end of the bathtub. <u>Exception: In an existing bathtub where bathroom is not reconfigured and a folding in-tub seat is installed, the additional 12 inches (305 mm) transfer clearance beyond the wall at the head end of the bathtub is not required if it would result in a reconfiguration of the space.</u></p> <p><b>FIGURE 607.2(B) CLEARANCE FOR BATHTUBS WITH SEAT TRANSFER PLATFORM AT HEAD END OF TUB</b></p> <p><b>FIGURE 607.2(C) CLEARANCE FOR BATHTUBS WITH FOLDING IN-TUB SEAT AT HEAD END OF TUB</b></p> <p><b>607.3 Seat.</b> A <u>permanent seat at the head end of the bathtub folding in-tub seat at the head end of the tub</u> or a removable in-tub seat shall be provided. Seats <u>and transfer platforms</u> shall comply with Section 610.</p> <p><b>607.4 Grab bars.</b> Grab bars shall comply with Section 609 and shall be provided in accordance with Section 607.4.1 or 607.4.2. <b>Exception:</b> Grab bars shall not be required to be installed in a bathing facility for a single occupant accessed only through a private office and not for common use or public use, provided reinforcement has been installed in walls and located so as to permit the installation of grab bars complying with Section 607.4.</p> <p><b>607.4.1 Bathtubs with permanent seats transfer platforms.</b> For bathtubs with <u>permanent seats transfer platforms</u>, grab bars complying with Section 607.4.1 shall be provided.</p> <p><b>Figure 607.4.1(A) Grab Bars for Bathtubs with Seat-Transfer Platforms at Head End of Tub – Elevation</b> <b>Figure 607.4.1(B) Grab Bars for Bathtubs with Seat-Transfer Platforms at Head End of Tub – Plan</b></p> <p><b>607.4.2 Bathtubs with removable in-tub seats.</b> For bathtubs with removable <u>in-tub</u> seats, grab bars complying with Section 607.4.2 shall be provided.</p> <p><b>Figure 607.4.2(A) Grab Bars for Bathtubs with Removable In-tub Seats – Elevation</b> <b>Figure 607.4.2(B) Grab Bars for Bathtubs with Removable In-tub Seats - Plan</b></p> <p><b>607.4.3 Bathtubs with folding in-tub seats.</b> For bathtubs with <u>folding in-tub seats at the head end of the tub, grab bars complying with Section 607.4.3 shall be provided.</u></p> <p><b>607.4.3.1 Back wall.</b> <u>Two horizontal grab bars shall be provided on the back wall, one complying with Section 609.4 and the other located 8 inches (205 mm) minimum and 10 inches (255 mm) maximum above the rim of the bathtub. Each grab bar shall be 30 inches (610mm) minimum in length, located 18 inches (610 mm) maximum from the head end wall and extend to 12 inches (305 mm) maximum from the control end wall.</u></p> <p><b>Control end wall.</b> <u>Control end wall grab bars shall comply with Section 607.4.3.2.</u> <b>Exception:</b> <u>An L-shaped continuous grab bar of equivalent dimensions and positioning shall be permitted to serve the function of separate vertical and horizontal grab bars.</u></p> <p><b>607.4.3.2.1 Horizontal grab bar.</b> <u>A horizontal grab bar 24 inches (610 mm) minimum in length shall be provided on the control end wall beginning near the front edge of the bathtub and extending toward the inside corner of the bathtub.</u></p> <p><b>607.4.3.2.2 Vertical grab bar.</b> <u>A vertical grab bar 18 inches (455 mm) minimum in length shall be provided on the control end wall 3 inches (75 mm) minimum and 6 inches (150 mm) maximum above the horizontal grab bar, and 4 inches (100 mm) maximum inward from the front edge of the bathtub.</u></p> <p><b>FIGURE 607.4.3(A) GRAB BARS FOR BATHTUBS WITH FOLDING IN-TUB SEATS – ELEVATION</b></p> <p><b>FIGURE 607.4.3(B) GRAB BARS FOR BATHTUBS WITH FOLDING IN-TUB SEATS –PLAN</b></p> <p><i>(Note: The intent is to be coordinated with the modification for controls for all tubs.)</i></p> <p><b>607.5 Controls.</b> <u>The operable parts of the on/off water floor, temperature and diverter controls</u> Controls, <u>other than drain stoppers</u>, shall be provided on an end wall, located between the bathtub rim and grab bar, and between the open side of the bathtub and the centerline of the width of the</p>		



**Report for 06-45- 2021**

bathtub. Such Controls shall comply with Section 309.4.

(Note: The intent is to be coordinated with the modification for hand showers for all tubs.)

**607.6 Hand shower.** A hand shower with a hose 59 inches (1500 mm) minimum in length, that can be used as both a fixed shower head and as a hand shower, shall be provided. The hand shower shall have ~~a control with~~ a nonpositive shut-off feature. A fixed shower head, in addition to the hand shower shall be permitted.

Exception: In other than Accessible units and Type A units, a fixed shower head located 48 inches (1220 mm) maximum above the shower floor shall be permitted in lieu of a hand shower.

A mount to hold the hand shower shall be provided and located in accordance with Section 607.6.1 or 607.6.2 as applicable. Where provided, an adjustable-height hand shower mounted on a vertical bar shall be installed so as to not obstruct the use of grab bars.

Exception: The mount to hold the hand shower shall be permitted to be located on a vertical bar provided that the mount is adjustable in height and the mount can be located within the area specified for the fixed mount.

**607.6.1 Bathtubs with removable in-tub seats.** For a bathtub with a moveable in-tub seat, the mount to hold the hand shower shall be located in accordance with the following:

1. At a height of 38 inches (965 mm) minimum and 48 inches (1220 mm) maximum above the tub floor.
2. Located on the control wall opposite the seat and located within 15 inches (380 mm) maximum from the centerline of the seat.

Exception: The mount to hold the hand shower shall be permitted to be located on a vertical bar provided that the mount is adjustable in height and can be located within the area specified for the fixed mount.

**607.6.2 Bathtubs with folding seats.** For a bathtub with a folding seat, the mount to hold the hand shower shall be located in accordance with the following:

1. At a height of 38 inches (965 mm) minimum and 48 inches (1220 mm) maximum above the tub floor.
2. Located on the back wall 16 inches (405 mm) minimum and 27 inches (685 mm) maximum from the wall behind the seat.

Exception: The mount to hold the hand shower shall be permitted to be located on a vertical bar provided that the mount is adjustable in height and can be located within the area specified for the fixed mount.

**FIGURE 607.6.2 LOCATION OF MOUNT FOR BATHTUB WITH FOLDING SEAT**

**609.4.1 General.** Grab bars shall be installed in a horizontal position, 33 inches (840 mm) minimum and 36 inches (915 mm) maximum above the floor measured to the top of the gripping surface or shall be installed as required by Items 1 through 3.

1. The lower grab bar on the back wall of a bathtub shall comply with Section 607.4.1.1, or 607.4.2.1 or 607.4.3.1.
2. Vertical grab bars shall comply with Sections 604.5.1.2, 607.4.1.2.2, 607.4.2.2, 607.4.3.2.2 and 608.3.1.2.
3. Grab bars at water closets primarily for children's use shall comply with Section 609.4.2.

**610.2 Bathtub seats.** The height of bathtub seats shall be 17 inches (430 mm) minimum and 19 inches (485 mm) maximum above the bathroom floor, measured to the top of the seat. Bathtub seats shall be rectangular in shape.

**610.2.1 Removable in-tub seats.** Removable in-tub seats shall be 15 inches (380 mm) minimum and 16 inches (405 mm) maximum in depth. Removable in-tub seats shall be capable of secure placement.

**FIGURE 610.2(A) 610.2.1 BATHTUB SEATS REMOVABLE IN-TUB SEATS**

**610.2.2 Bathtubs with transfer platforms.** ~~Permanent seats~~ Transfer platforms shall be 15 inches (380 mm) minimum in depth and shall extend from the back wall to or beyond the outer edge of the bathtub. ~~Permanent seats~~ Transfer platforms shall be positioned at the head end of the bathtub.

**FIGURE 610.2(B) 610.2.2 BATHTUB SEATS SEAT TRANSFER PLATFORM PROVIDED AT HEAD END OF TUB**

**610.2.3 Folding in-tub seats.** Folding in-tub seats shall be mounted on the head wall. The rear edge of a seat shall be 2-1/2 inches (64 mm) maximum and the seat shall be 15 inches (380 mm) minimum and 16 inches (405 mm) maximum in depth. The side edge of the seat shall be 1-1/2 inches (38 mm) maximum from the back wall.

**FIGURE 610.2.3 BATHTUB SEATS FOLDING IN-TUB SEAT PROVIDED AT HEAD END OF TUB**

Committee Reason: The option for a folding seat at the head end of a tub provides some definite advantages over the removeable seat. By being mounted this reduces the chance of the seat slipping and makes sure that the seat does not disappear from the room. This also allow for the person to put down the seat themselves rather than needed staff to come and install the portable seat. This also provides a back rest for a person using the tub. Some of the task group felt that providing for a back rest and having the seat overlap the tub so that it could be used for showering was an improvement for accessibility, even without being able to adjust the water while showering. The proposal does put the hand shower mount within reach of the seat. Since there was some concern about the limited leg space with the removeable seat close to the control wall, this option also provides space for someone that needed more leg room.

There was discussion about the scoping for the three options for bathtubs. The task group stated that the intent was for no change to the scoping and to allow for any of the three options.

**PUBLIC COMMENT- FIRST DRAFT:**

Proponent:

Desired Action:

Modification:

Reason:

**Committee decision: AS/AM/D**

**Committee Vote at Meeting:**

**Committee Vote on Ballot:**

**REPORT OF HEARING – FIRST DRAFT**

Modification (if any):

<b>Report for 06-45- 2021</b>		
Committee Reason:		
<b>PUBLIC COMMENT- SECOND DRAFT:</b>		
Proponent:		
Desired Action:		
Modification:		
Reason:		
<b>Committee decision: AS/AM/D</b>	<b>Committee Vote at Meeting:</b>	<b>Committee Vote on Ballot:</b>
<b>FINAL ACTION:</b>		
Modification (if any):		
Committee Reason:		



# 06-46 – 2021

## 607.5, 607.5.1(New), 607.5.2(New), Figure 607.5, 607.5.1(New)

**Proponent:** Hope Reed, ADA Accessibility Consultant, representing self

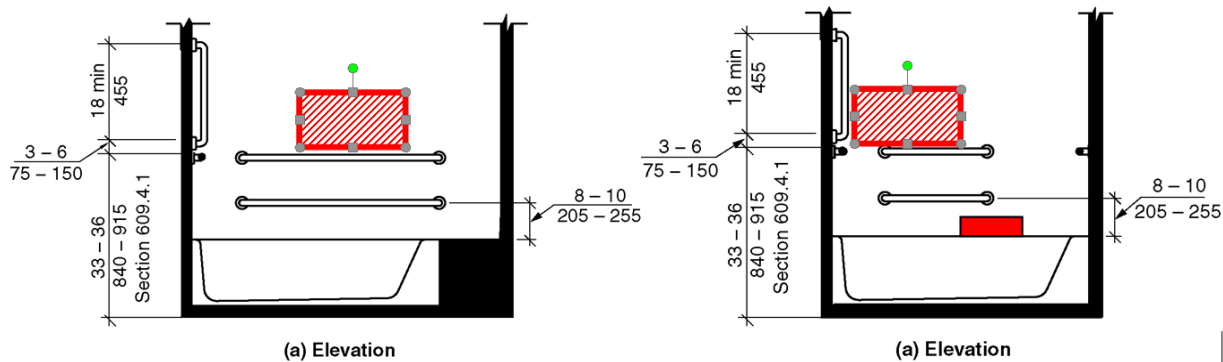
**Revise as follows:**

### SECTION 607 BATHTUBS

**607.5 Controls.** Controls, other than drain stoppers, shall be provided at two locations, on an end wall and the back wall. Back walls controls shall comply with Section 607.5.1. End wall controls shall comply with Section 607.5.2.

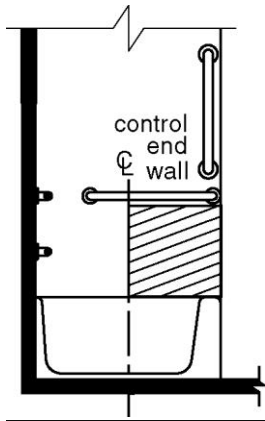
**607.5.1 Back wall controls.** Controls shall be located on the back wall at a height of 38 inches (965 mm) minimum and 48 inches (1220 mm) maximum above the bathtub floor and 16 inches (405 mm) minimum and 27 inches (685 mm) maximum from the wall behind the seat.

*Note: Add two new figures with dimensions to match text for rear wall controls.*



**FIGURE 607.5.1**  
**LOCATION OF BATHTUB CONTROLS ON BACK WALLS**

**607.5.2 End wall controls.** Controls shall be located between the bathtub rim and grab bar, and between the open side of the bathtub and the centerline of the width of the bathtub. Controls shall comply with 309.4.



**FIGURE 607.5 607.5.2**  
**LOCATION OF BATHTUB CONTROLS ON END WALL**

**REASON:** Provide controls for people using the *permanent seat* and those who need to stand using the *permanently fixed shower head* located at the foot end. Serve varying levels of disability and allow a standard showering set up for care giver, spouse, and friends who will be sharing one bathroom with a person who uses the shower seat. Controls at both locations are important for safety by reducing the need to turn on a wet shower floor.

## **06-46 – 2021 modification**

**607.5, 607.5.1(New), 607.5.2(New), Figure 607.5, 607.5.1(New)**

**Proponent:** Hope Reed, ADA Accessibility Consultant, representing self

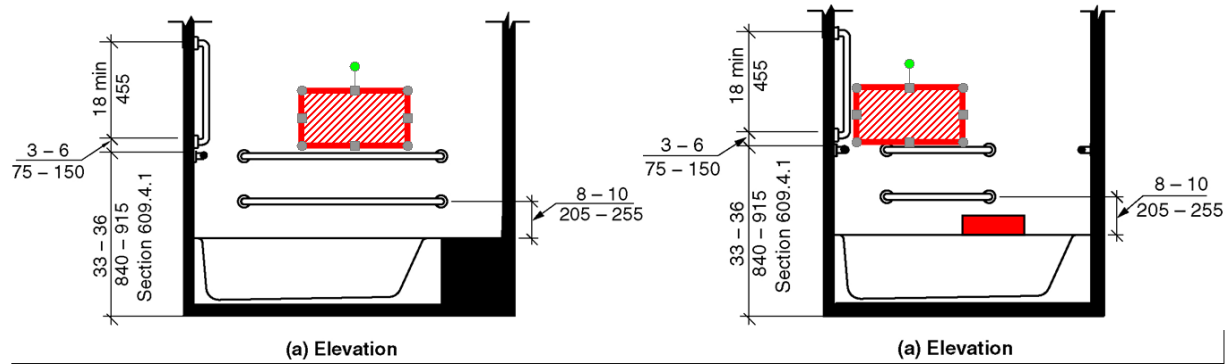
**Further revise as follows:**

### **SECTION 607** **BATHTUBS**

**607.5 Controls.** Controls, other than drain stoppers, shall be provided ~~at two locations~~, on an end wall and the back wall. Back walls controls shall comply with Section 607.5.1. End wall controls shall comply with Section 607.5.2. Controls shall comply with 309.4.

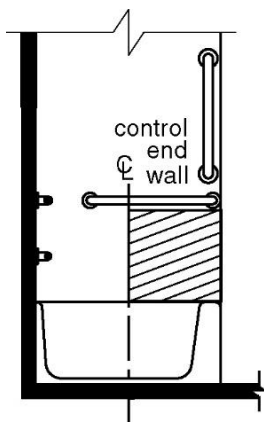
**607.5.1 Back wall controls.** ~~Controls~~ Diverters that control water to the hand shower and a mount to hold the hand shower shall be located on the back wall at a height of 38 inches (965 mm) minimum and 48 inches (1220 mm) maximum above the bathtub floor and 16 inches (405 mm) minimum and 27 inches (685 mm) maximum from the wall behind the seat.

*Note: Add two new figures with dimensions to match text for rear wall controls.*



**FIGURE 607.5.1**  
**LOCATION OF BATHTUB CONTROLS DIVERTERS AND MOUNTS ON BACK WALLS**

**607.5.2 End wall controls.** Controls shall be located between the bathtub rim and grab bar, and between the open side of the bathtub and the centerline of the width of the bathtub. ~~Controls shall comply with 309.4.~~



**FIGURE 607.5.2**  
**LOCATION OF BATHTUB CONTROLS ON END WALL**

**REASON:** The plumbing regulations do not allow for two sets of controls in the same tub enclosure due to water use limitations. Allowing for the shower diverter and a mount to hold the hand shower on the back wall within reach of the seat would allow the person on the seat to turn the water on and off.

Committee Action: D 24-2-0

**REPORT OF HEARING:**

**Modification (if any):**

**Committee Reason:** The committee felt that the hand shower on the back wall was not needed for the removable seat since you could position the seat to have access to the controls and hand shower on the back wall. There were concerns raised about the seat past the head of the tub not being a place someone could shower. If the purpose is for someone to use this transfer platform as a tub instead of a shower, the hand shower is not needed on the back wall.

**607.5-REED.doc**

<b>Report for 06-46– 2021</b>		
<i>Committee decision: D</i>	<i>Committee Vote at Meeting: 24-2-0</i>	<i>Committee Vote on Ballot:</i>
<b>REPORT OF HEARING:</b>		
Modification (if any):		
Committee Reason: The committee felt that the hand shower on the back wall was not needed for the removable seat since you could position the seat to have access to the controls and hand shower on the back wall. There were concerns raised about the seat past the head of the tub not being a place someone could shower. If the purpose is for someone to use this transfer platform as a tub instead of a shower, the hand shower is not needed on the back wall.		
<b>PUBLIC COMMENT- FIRST DRAFT:</b>		
Proponent:		
Desired Action:		
Modification:		
Reason:		
<i>Committee decision: AS/AM/D</i>	<i>Committee Vote at Meeting:</i>	<i>Committee Vote on Ballot:</i>
<b>REPORT OF HEARING – FIRST DRAFT</b>		
Modification (if any):		
Committee Reason:		
<b>PUBLIC COMMENT- SECOND DRAFT:</b>		
Proponent:		
Desired Action:		
Modification:		
Reason:		
<i>Committee decision: AS/AM/D</i>	<i>Committee Vote at Meeting:</i>	<i>Committee Vote on Ballot:</i>
<b>FINAL ACTION:</b>		
Modification (if any):		
Committee Reason:		

## 06-47 – 2021

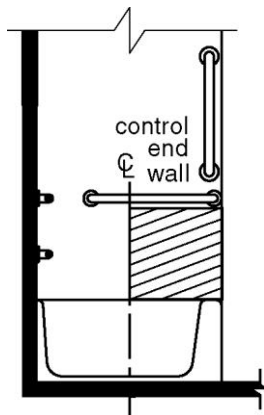
607.5, 608.4, 608.4.1, 608.4.2, 608.4.3

**Proponent:** Kyle Thompson, Plumbing Manufacturers International (PMI)

**Revise as follows:**

### SECTION 607 BATHTUBS

**607.5 Controls.** Temperature and on-or-off flow controls for bathtubs or combination tub-or-showers, and controls for shower diversion, Controls other than drain stoppers, shall be provided on an end wall, located between the bathtub rim and grab bar, and between the open side of the bathtub and the centerline of the width of the bathtub. Such controls shall comply with Section 309.4.



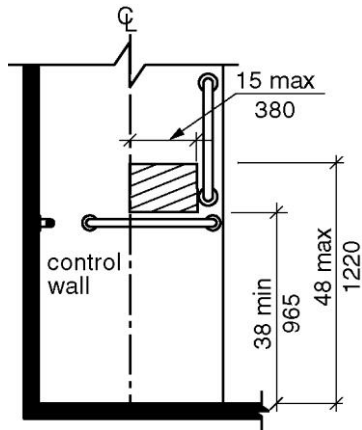
**FIGURE 607.5  
LOCATION OF BATHTUB CONTROLS**

### SECTION 608 SHOWER COMPARTMENTS

**608.4 Controls ~~and hand showers.~~** Controls for temperature and on-or-off flow controls for showers and where provided, controls for shower diversion, and hand showers shall comply with Sections 608.4.1 through Section 608.4.3 and Section 309.4.

**608.4.1 Transfer-type showers.** In transfer-type showers, the controls ~~and hand shower~~ shall be located in accordance with all of the following:

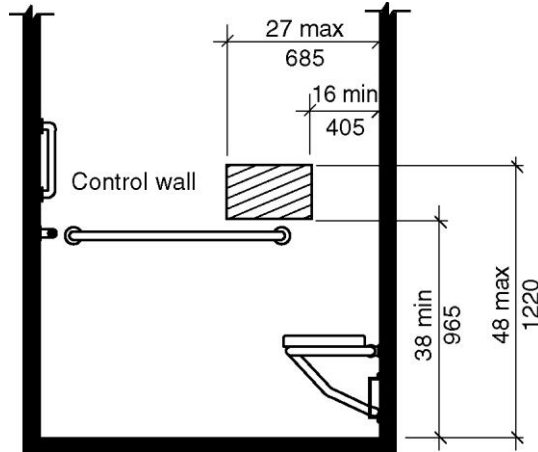
1. On the control wall opposite the seat.
2. At a height of 38 inches (965 mm) minimum and 48 inches (1220 mm) maximum above the shower floor, and
3. 15 inches (380 mm) maximum, from the centerline of the control wall toward the shower opening.



**FIGURE 608.4.1**  
**TRANSFER-TYPE SHOWER CONTROLS AND HAND SHOWER LOCATION**

**608.4.2 Standard roll-in showers.** In standard roll-in showers, the controls ~~and hand shower~~ shall be located above the seat. ~~The controls and hand showers~~ shall be located in accordance with all of ~~according to~~ the following:

1. On the back wall,
2. At a height of 38 inches (965 mm) minimum and 48 inches (1220 mm) maximum above the shower floor and
3. 16 inches (405 mm) minimum and 27 inches (685 mm) maximum from the wall behind the seat.

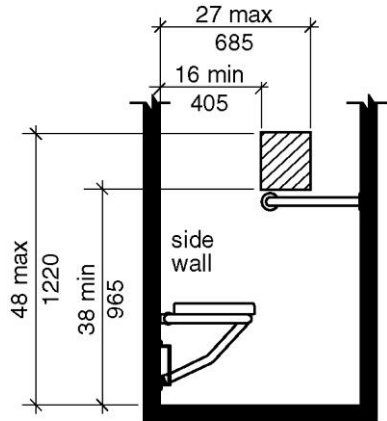


**FIGURE 608.4.2**  
**STANDARD ROLL-IN-TYPE SHOWER CONTROLS AND HAND SHOWER LOCATION**

**608.4.3 Alternate roll-in showers.** In alternate roll-in showers, the controls ~~and hand shower~~ shall be located at a height of not less than 38 inches (965 mm) and not greater than 48 inches above the shower floor, and in accordance with one of the following:

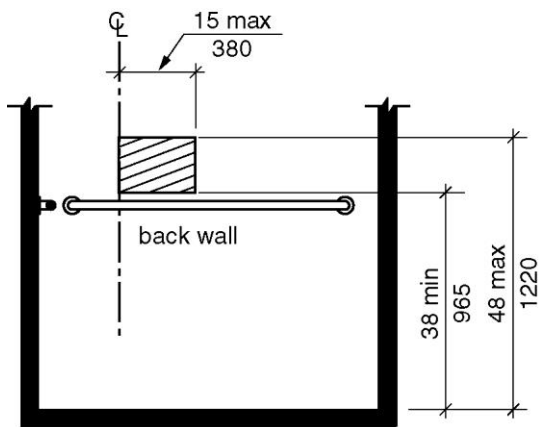
1. ~~At a height of 38 inches (965 mm) minimum and 48 inches (1220 mm) maximum above the shower floor, and~~

1. ~~2.~~ Where the controls and hand shower are located on the end wall adjacent to the seat, the controls and hand shower shall be 16 inches (405 mm) minimum and 27 inches (685 mm) maximum from the wall behind the seat wall, or
2. ~~3.~~ Where the controls and hand shower are located on the back wall opposite the seat, the controls and hand shower shall be located within 15 inches (380 mm) maximum from the centerline of the seat toward the transfer space.



(a)  
Side Wall  
(Elevation)

**FIGURE 608.4.3(A)**  
**ALTERNATE ROLL-IN-TYPE SHOWER CONTROLS AND HAND SHOWER**  
**LOCATION - END WALL - ELEVATION**



(b)  
Back Wall  
(Elevation)

**FIGURE 608.4.3(B)**  
**ALTERNATE ROLL-IN-TYPE SHOWER CONTROLS AND HAND SHOWER**  
**LOCATION - CONTROL WALL - ELEVATION**

**REASON:** As shown in Figures 607.5, 608.4.1, 608.4.2, 608.4.3(A) and 608.4.3(B) below, inspectors have on occasion enforced that the means to hold the hand shower be located in the

shaded area along with other controls. The proposed code change clarifies that only temperature, on-or-off flow and shower diversion controls are required to be located in the shaded area as it impossible in most instances to include all of these controls along with the means to hold the hand shower in such small spaces. Also, the proposed modifications make it clear that only temperature, on-or-off flow controls and shower diversion controls are required to meet the requirements of Section 309.4. It should be noted that requirements for hand showers are already addressed in Sections 607.6 and 608.5.

---

## 06-47 – 2021 Replacement

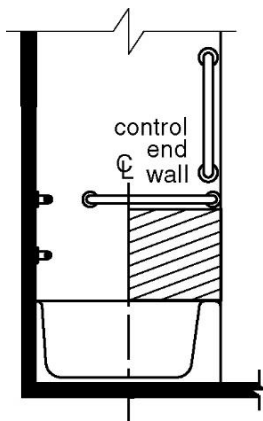
### 607.5, 608.4, 608.4.1, 608.4.2, 608.4.3

**Proponent:** Accessible Bathing Task Group

**Replace with the following:**

#### SECTION 607 BATHTUBS

**607.5 Controls.** ~~Controls other than drain stoppers,~~ The operable parts for the on/off water flow, temperature and divertor controls shall be provided on an end wall, located between the bathtub rim and grab bar, and between the open side of the bathtub and the centerline of the width of the bathtub. Such controls shall comply with Section 309.4.



**Figure 607.5**  
LOCATION OF BATHTUB CONTROLS

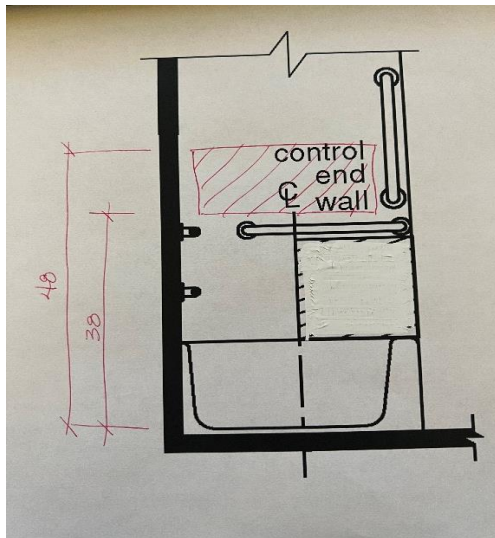
**607.6 Hand shower.** A hand shower with a hose 59 inches (1500 mm) minimum in length, ~~that~~ can be used as both a fixed shower head and as a hand shower, shall be provided. The hand shower shall have ~~a control with~~ a nonpositive shut-off feature. A fixed shower head, in addition to the hand shower shall be permitted.



**Exception:** In other than Accessible units and Type A units, a fixed shower head located 48 inches (1220 mm) maximum above the shower floor shall be permitted in lieu of a hand shower.

A mount to hold the hand shower shall be provided and located on the control wall at a height of 38 inches (965 mm) minimum and 48 inches (1220 mm) maximum above the tub floor. Where provided, an adjustable height hand shower mounted on a vertical bar shall be installed so as to not obstruct the use of grab bars.

**Exception:** The mount to hold the hand shower shall be permitted to be located on a vertical bar provided that the mount is adjustable in height and the mount can be located within the area specified for the fixed mount.



**Figure 607.6**

**LOCATION OF BATHTUB HAND SHOWER MOUNT LOCATION**

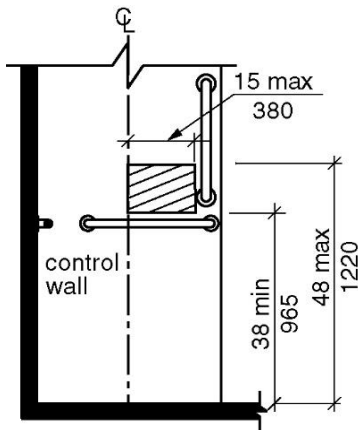
## **SECTION 608 SHOWER COMPARTMENTS**

**608.4 Controls and hand showers.** The operable parts for the on/off water flow, temperature and diverter Controls and hand showers shall comply with Section 309.4 and Sections 608.4.1, 608.4.2 or 608.4.3 as applicable and 309.4.

**608.4.1 Controls in Transfer-type showers.** In transfer-type showers, the operable parts for the on/off water flow, temperature and diverter controls and hand shower shall be located in accordance with all of the following:

1. On the control wall opposite the seat.
2. At a height of 38 inches (965 mm) minimum and 48 inches (1220 mm) maximum above the shower floor, and

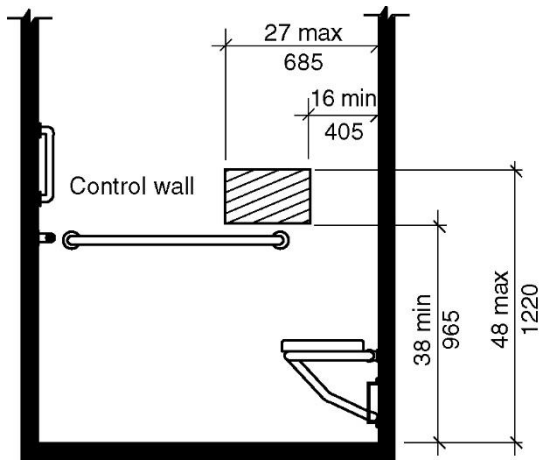
- 15 inches (380 mm) maximum, from the centerline of the control wall toward the shower opening.



**FIGURE 608.4.1**  
**TRANSFER-TYPE SHOWER CONTROLS AND HAND SHOWER LOCATION**

**608.4.2 Controls in Standard roll-in showers.** In standard roll-in showers, the operable parts for the on/off water flow, temperature and diverter controls and hand shower shall not be located above the seat. ~~Controls and hand showers shall be located in accordance with all of~~ according to the following:

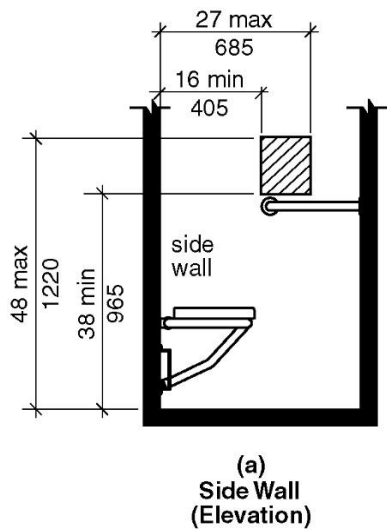
- On the back wall;
- At a height of 38 inches (965 mm) minimum and 48 inches (1220 mm) maximum above the shower floor ~~and~~
- 16 inches (405 mm) minimum and 27 inches (685 mm) maximum from the wall behind the seat.



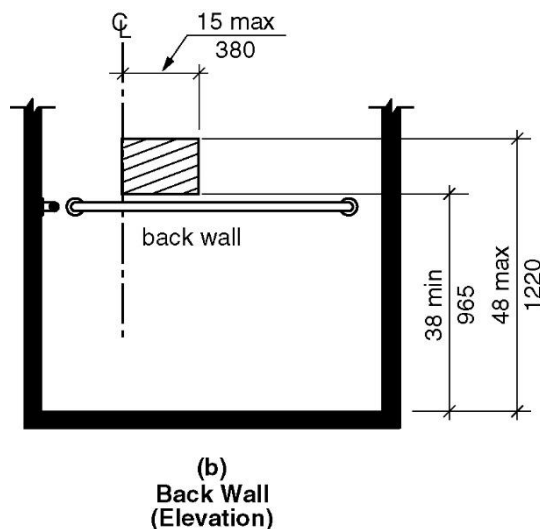
**FIGURE 608.4.2**  
**STANDARD ROLL-IN-TYPE SHOWER CONTROLS AND HAND SHOWER LOCATION**

**608.4.3 Controls in Alternate roll-in showers.** In alternate roll-in showers, the operable parts for the on/off water flow, temperature and divertor controls and hand shower shall be located in accordance with the following:

1. At a height of 38 inches (965 mm) minimum and 48 inches (1220 mm) maximum above the shower floor, ~~and~~
2. Where the controls ~~and hand shower~~ are located on the end wall adjacent to the seat, the controls ~~and hand shower~~ shall be 16 inches (405 mm) minimum and 27 inches (685 mm) maximum from the wall behind the seat wall, ~~or~~
3. Where the controls ~~and hand shower~~ are located on the back wall opposite the seat, the controls ~~and hand shower~~ shall be located within 15 inches (380 mm) maximum from the centerline of the seat toward the transfer space.



**FIGURE 608.4.3(A)  
ALTERNATE ROLL-IN-TYPE SHOWER CONTROLS AND ~~HAND SHOWER~~  
LOCATION - END WALL - ELEVATION**



**FIGURE 608.4.3(B)**  
**ALTERNATE ROLL-IN-TYPE SHOWER CONTROLS AND HAND SHOWER**  
**LOCATION - CONTROL WALL – ELEVATION**

**608.5 Hand showers.** A hand shower with a hose 59 inches (1500 mm) minimum in length, that can be used both as a fixed shower head and as a hand shower, shall be provided. The hand shower shall have a control with a nonpositive shut-off feature. A fixed shower head, in addition to the hand shower shall be permitted.

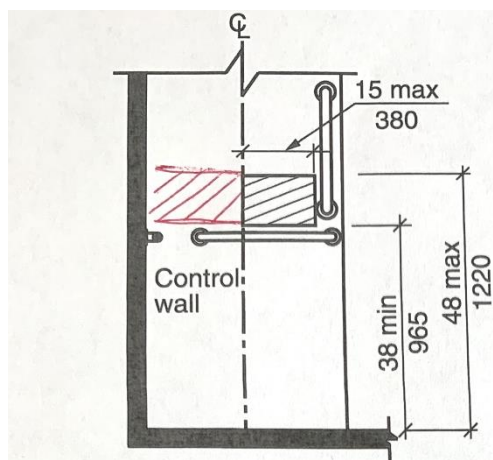
**Exception:** In other than Accessible units and Type A units, a fixed shower head located 48 inches (1220 mm) maximum above the shower floor shall be permitted in lieu of a hand shower.

A means mount to hold the hand shower wand while in the on or off position shall be provided and located in accordance with Sections 608.5.1, 608.5.2 or 608.5.3 as applicable. at a height of 38 inches (965 mm) minimum and 48 inches (1220 mm) maximum above the shower finish floor. Where provided, an adjustable height hand shower mounted on a vertical bar shall be installed so as to not obstruct the use of grab bars.

**608.5.1 Hand Showers mounts in Transfer-type showers.** In transfer-type showers, the mount to hold the hand shower shall be located in accordance with to the following:

2. At a height of 38 inches (965 mm) minimum and 48 inches (1220 mm) maximum above the shower floor.
2. Where the mount is located on the back wall, the mount shall be 16 inches (405 mm) minimum and 27 inches (685 mm) maximum from the wall behind the seat.
3. Where the mount located on the control wall opposite the seat, the mount shall be located within 15 inches (380 mm) maximum from the centerline of the seat.

**Exception:** The mount to hold the hand shower shall be permitted to be located on a vertical bar provided that the mount is adjustable in height and can be located within the area specified for the fixed mount.

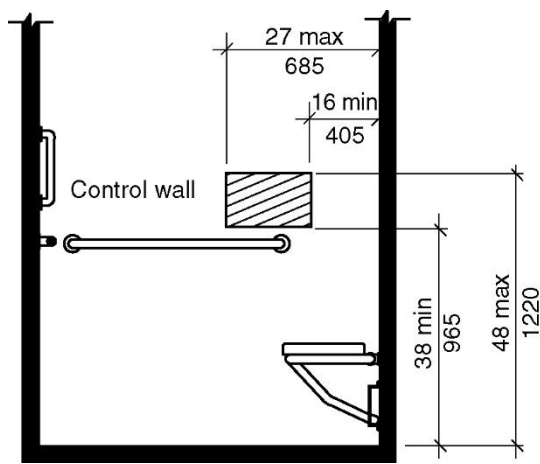


**FIGURE 608.5.1**  
**TRANSFER-TYPE SHOWER HAND SHOWER MOUNT LOCATION**

**608.5.2 Hand Showers mounts in Standard roll-in showers.** In standard roll-in showers, the mount to hold the hand shower shall be located in accordance with the following:

2. At a height of 38 inches (965 mm) minimum and 48 inches (1220 mm) maximum above the shower floor.
2. Located on the back wall 16 inches (405 mm) minimum and 27 inches (685 mm) maximum from the wall behind the seat.

**Exception:** The mount to hold the hand shower shall be permitted to be located on a vertical bar provided that the mount is adjustable in height and can be located within the area specified for the fixed mount.

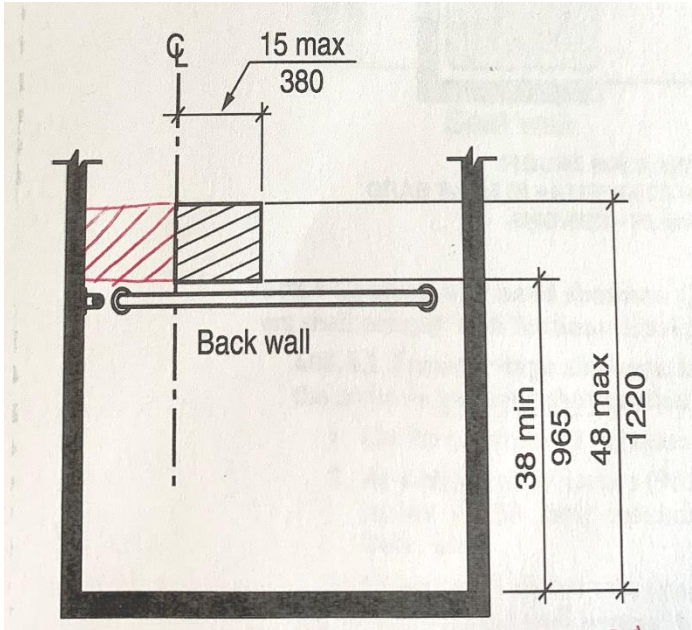


**FIGURE 608.4.2**  
**STANDARD ROLL-IN-TYPE SHOWER HAND SHOWER MOUNT LOCATION**

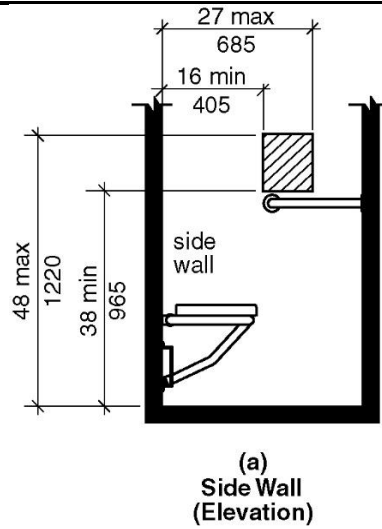
**608.5.3 Hand Showers mounts in Alternate roll-in showers.** In alternate roll-in showers, the mount to hold the hand shower shall be located in accordance with the following:

1. At a height of 38 inches (965 mm) minimum and 48 inches (1220 mm) maximum above the shower floor.
2. Where the mount is located on the end wall adjacent to the seat, the mount shall be 16 inches (405 mm) minimum and 27 inches (685 mm) maximum from the wall behind the seat.
3. Where the mount is located on the back wall opposite the seat, the mount shall be located within 15 inches (380 mm) maximum from the centerline of the seat.

**Exception:** The mount to hold the hand shower shall be permitted to be located on a vertical bar provided that the mount is adjustable in height and can be located within the area specified for the fixed mount.



**FIGURE 608.4.3(C) ALTERNATE ROLL-IN-TYPE SHOWER HAND SHOWER MOUNT LOCATION - END WALL – ELEVATION**



**FIGURE 608.4.3(D) ALTERNATE ROLL-IN-TYPE SHOWER HAND SHOWER MOUNT LOCATION - CONTROL WALL – ELEVATION**

**SECTION 609**

## GRAB BARS

**609.3 Spacing.** The space between the wall and the grab bar shall be 1½ inches (38 mm). The space between the grab bar and projecting objects below and at the ends of the grab bar shall be 1½ inches (38 mm) minimum. The space between the grab bar and projecting objects above the grab bar shall be 12 inches (305 mm) minimum.

### Exceptions:

1. The space between the grab bars and shower operable parts for the on/off water flow, temperature and diverter controls, shower or bathtub fittings, including the vertical bar for the adjustable mount for the hand shower, and other grab bars above the grab bar shall be permitted to be 1½ inches (38 mm) minimum.
2. Recessed dispensers projecting from the wall ¼ inch (6.4 mm) maximum measured from the face of the dispenser and complying with Section 604.7 shall be permitted within the 12-inch (305 mm) space above and the 1½-inch (38 mm) spaces below and at the ends of the grab bar.

Reason: The Accessible Bathing Task Group took a look at all the proposal for clarification of the location of the controls and the requirements for hand showers used in tubs and showers. This modification does not address proposals that reduced or increased the size of the control area.

The work group feels that this will address issues in items 06-47, 06-48, 06-49, 06-51, 06-52, 06-66, 06-68

06-53 – Mazz modification to Exception 2

06-54, 06-55, 06-69, 06-70 – except for the part about allow adjustment of spray direction

06-67 - Could be adding additional control area for transfer showers. Should be expanded to alternate roll-in showers.

The following would need coordination –

06-61- If passes, coordination needed with controls and hand showers.

06-62 - If passes, coordination needed with controls and hand showers.

Assumptions - In other than roll-in showers, the water is turned on before you transfer, so access to the controls is from the transfer space. In the roll-in shower access to controls is from the seat. The location of the mount to hold the hand shower is convenient to the person when they are on the seat.

- The current text is inconsistent in language. This modification uses consistent terminology in tubs and showers.
- The current text is inconsistent for what is included in the control area (sometimes including hand showers) – to address this the task group is recommending a split between requirements for controls, and requirements for hand showers and the supporting mount.

- There were question about what controls or included – to address this the task group is recommending “operable parts for the on/off water flow, temperature and diverter controls”. Some tub/shower controls have temperature
- There were questions about what part of the controls had to be within the area specified – to address this the committee is suggesting “operable parts” so you do not have to include back plate escutcheons.
- There are questions about if the hand shower has to serve as the fixed shower head or a tub/shower could have a fixed head and a hand shower with a diverter to switch from one to the other – to address this the task group is recommending “A fixed shower head, in addition to the hand shower shall be permitted.”
- The hand shower consists of the hose, the shower head and the non-positive shut off valve. For clarification, this modification specifies a mount to hold the hand shower within reach of the seat and above the grab bar. Current language does exist to allow for an adjustable height mount on a vertical grab bar – this modification clarifies the text and moves it to an exception.
- Current language says the vertical bar shall not obstruct the grab bars, but this was open to interpretation - The general provisions for grab bars (609.3) has been revised to clarify how close that vertical bar can be to grab bars.

Committee Action: Approval as Modified 26-0-1

**REPORT OF HEARING:**

**Modification (if any):** See the replacement proposal above.

**Committee Reason:** The committee agreed that this modification will address issues in items 06-47, 06-48, 06-49, 06-51, 06-52, 06-66, 06-68.

This proposal will coordinate the requirements and terminology for controls and hand showers across tubs and showers. The revision for which controls are expected within the specified area, and that the operable parts of those controls need to be within this area is a good clarification. The proposal clarifies that a fixed shower head in addition to the hand shower is permitted. The committee felt that requirements for a hand shower mount was always intended, and the revisions clarify that the mount for the hand shower is within reach of the seat. The allowance for an adjustable mount on a vertical grab bar is clarified with the relocation to the exception, the rewording and the added text in Section 609.3 Exception 1.

**607.5 THOMPSON.doc**

<b>Report for 06-47– 2021</b>		
<b>Committee decision: AM</b>	<b>Committee Vote at Meeting: 26-0-1</b>	<b>Committee Vote on Ballot:</b>
<b>REPORT OF HEARING:</b>		
Modification (if any): See the replacement proposal above.		
<p><b>607.5 Controls.</b> <del>Controls other than drain stoppers.</del> The operable parts for the on/off water flow, temperature and diverter controls shall be provided on an end wall, located between the bathtub rim and grab bar, and between the open side of the bathtub and the centerline of the width of the bathtub. <u>Such</u> controls shall comply with Section 309.4.</p>		



## Report for 06-47- 2021

**607.6 Hand shower.** A hand shower with a hose 59 inches (1500 mm) minimum in length, that can be used as both a fixed shower head and as a hand shower, shall be provided. The hand shower shall have a control with a nonpositive shut-off feature. A fixed shower head, in addition to the hand shower shall be permitted.

**Exception:** In other than Accessible units and Type A units, a fixed shower head located 48 inches (1220 mm) maximum above the shower floor shall be permitted in lieu of a hand shower.

A mount to hold the hand shower shall be provided and located on the control wall at a height of 38 inches (965 mm) minimum and 48 inches (1220 mm) maximum above the tub floor. Where provided, an adjustable-height hand shower mounted on a vertical bar shall be installed so as to not obstruct the use of grab bars.

**Exception:** The mount to hold the hand shower shall be permitted to be located on a vertical bar provided that the mount is adjustable in height and the mount can be located within the area specified for the fixed mount.

**608.4 Controls and hand showers.** The operable parts for the on/off water flow, temperature and diverter Controls and hand showers shall comply with Section 309.4 and Sections 608.4.1, 608.4.2 or 608.4.3 as applicable and 309.4.

**608.4.1 Controls in Transfer-type showers.** In transfer-type showers, the operable parts for the on/off water flow, temperature and diverter controls and hand shower shall be located in accordance with all of the following:

1. On the control wall opposite the seat.
2. At a height of 38 inches (965 mm) minimum and 48 inches (1220 mm) maximum above the shower floor, and
3. 15 inches (380 mm) maximum, from the centerline of the control wall toward the shower opening.

### FIGURE 608.4.1 TRANSFER-TYPE SHOWER CONTROLS AND HAND-SHOWER LOCATION

**608.4.2 Controls in Standard roll-in showers.** In standard roll-in showers, the operable parts for the on/off water flow, temperature and diverter controls and hand shower shall not be located above the seat. Controls and hand showers shall be located in accordance with all of according to the following:

1. On the back wall, and
2. At a height of 38 inches (965 mm) minimum and 48 inches (1220 mm) maximum above the shower floor and
3. 16 inches (405 mm) minimum and 27 inches (685 mm) maximum from the wall behind the seat.

### FIGURE 608.4.2 STANDARD ROLL-IN-TYPE SHOWER CONTROLS AND HAND-SHOWER LOCATION

**608.4.3 Controls in Alternate roll-in showers.** In alternate roll-in showers, the operable parts for the on/off water flow, temperature and diverter controls and hand shower shall be located in accordance with the following:

1. At a height of 38 inches (965 mm) minimum and 48 inches (1220 mm) maximum above the shower floor, and
2. Where the controls and hand shower are located on the end wall adjacent to the seat, the controls and hand shower shall be 16 inches (405 mm) minimum and 27 inches (685 mm) maximum from the wall behind the seat, or
3. Where the controls and hand shower are located on the back wall opposite the seat, the controls and hand shower shall be located within 15 inches (380 mm) maximum from the centerline of the seat toward the transfer space.

### FIGURE 608.4.3(A) ALTERNATE ROLL-IN-TYPE SHOWER CONTROLS AND HAND-SHOWER LOCATION - END WALL - ELEVATION

### FIGURE 608.4.3(B) ALTERNATE ROLL-IN-TYPE SHOWER CONTROLS AND HAND-SHOWER LOCATION - CONTROL WALL - ELEVATION

**608.5 Hand showers.** A hand shower with a hose 59 inches (1500 mm) minimum in length, that can be used both as a fixed shower head and as a hand shower, shall be provided. The hand shower shall have a control with a nonpositive shut-off feature. A fixed shower head, in addition to the hand shower shall be permitted.

**Exception:** In other than Accessible units and Type A units, a fixed shower head located 48 inches (1220 mm) maximum above the shower floor shall be permitted in lieu of a hand shower.

A means mount to hold the hand shower wand while in the on or off position shall be provided and located in accordance with Sections 608.5.1, 608.5.2 or 608.5.3 as applicable, at a height of 38 inches (965 mm) minimum and 48 inches (1220 mm) maximum above the shower finish floor. Where provided, an adjustable-height hand shower mounted on a vertical bar shall be installed so as to not obstruct the use of grab bars.

**608.5.1 Hand Showers mounts in Transfer-type showers.** In transfer-type showers, the mount to hold the hand shower shall be located in accordance with to the following:

1. At a height of 38 inches (965 mm) minimum and 48 inches (1220 mm) maximum above the shower floor.
2. Where the mount is located on the back wall, the mount shall be 16 inches (405 mm) minimum and 27 inches (685 mm) maximum from the wall behind the seat.
3. Where the mount is located on the control wall opposite the seat, the mount shall be located within 15 inches (380 mm) maximum from the centerline of the seat.

**Exception:** The mount to hold the hand shower shall be permitted to be located on a vertical bar provided that the mount is adjustable in height and can be located within the area specified for the fixed mount.

### FIGURE 608.5.1 TRANSFER-TYPE SHOWER HAND SHOWER MOUNT LOCATION

**608.5.2 Hand Showers mounts in Standard roll-in showers.** In standard roll-in showers, the mount to hold the hand shower shall be located in accordance with to the following:

1. At a height of 38 inches (965 mm) minimum and 48 inches (1220 mm) maximum above the shower floor.
2. Located on the back wall 16 inches (405 mm) minimum and 27 inches (685 mm) maximum from the wall behind the seat.

**Exception:** The mount to hold the hand shower shall be permitted to be located on a vertical bar provided that the mount is adjustable in height and can be located within the area specified for the fixed mount.

### FIGURE 608.4.2

**Report for 06-47– 2021**

**STANDARD ROLL-IN-TYPE SHOWER HAND SHOWER MOUNT LOCATION**

**608.5.3 Hand Showers mounts in Alternate roll-in showers.** In alternate roll-in showers, the mount to hold the hand shower shall be located in accordance with to the following:

1. At a height of 38 inches (965 mm) minimum and 48 inches (1220 mm) maximum above the shower floor.
2. Where the mount is located on the end wall adjacent to the seat, the mount shall be 16 inches (405 mm) minimum and 27 inches (685 mm) maximum from the wall behind the seat.
3. Where the mount is located on the back wall opposite the seat, the mount shall be located within 15 inches (380 mm) maximum from the centerline of the seat.
  - a. **Exception:** The mount to hold the hand shower shall be permitted to be located on a vertical bar provided that the mount is adjustable in height and can be located within the area specified for the fixed mount.

**FIGURE 608.4.3(C) ALTERNATE ROLL-IN-TYPE SHOWER HAND SHOWER MOUNT LOCATION - END WALL – ELEVATION**

**FIGURE 608.4.3(D)**

**ALTERNATE ROLL-IN-TYPE SHOWER HAND SHOWER MOUNT LOCATION - CONTROL WALL – ELEVATION**

Committee Reason: The committee agreed that this modification will address issues in items 06-47, 06-48, 06-49, 06-51, 06-52, 06-66, 06-68. This proposal will coordinate the requirements and terminology for controls and hand showers across tubs and showers. The revision for which controls are expected within the specified area, and that the operable parts of those controls need to be within this area is a good clarification. The proposal clarifies that a fixed shower head in addition to the hand shower is permitted. The committee felt that requirements for a hand shower mount was always intended, and the revisions clarify that the mount for the hand shower is within reach of the seat. The allowance for an adjustable mount on a vertical grab bar is clarified with the relocation to the exception, the rewording and the added text in Section 609.3 Exception 1.

**PUBLIC COMMENT- FIRST DRAFT:**

Proponent:

Desired Action:

Modification:

Reason:

**Committee decision: AS/AM/D**

**Committee Vote at Meeting:**

**Committee Vote on Ballot:**

**REPORT OF HEARING – FIRST DRAFT**

Modification (if any):

Committee Reason:

**PUBLIC COMMENT- SECOND DRAFT:**

Proponent:

Desired Action:

Modification:

Reason:

**Committee decision: AS/AM/D**

**Committee Vote at Meeting:**

**Committee Vote on Ballot:**

**FINAL ACTION:**

Modification (if any):

Committee Reason:

## 06-48 – 2021

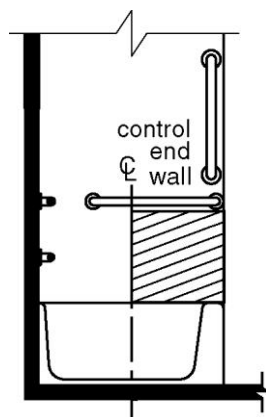
### 607.5, 608.4, 608.4.1, 608.4.2, 608.4.3

**Proponent:** Kimberly Paarlberg, International Code Council

**Revise as follows:**

#### SECTION 607 BATHTUBS

**607.5 Controls.** The operable portion of controls ~~Controls~~, other than drain stoppers, shall be provided on an end wall, located between the bathtub rim and grab bar, and between the open side of the bathtub and the centerline of the width of the bathtub. Controls shall comply with Section 309.4.



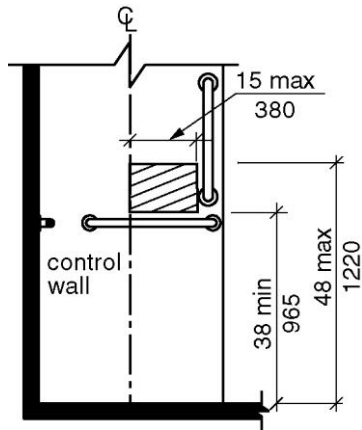
**FIGURE 607.5**  
**LOCATION OF BATHTUB CONTROLS**

#### SECTION 608 SHOWER COMPARTMENTS

**608.4 Controls and hand showers.** The operable portion of controls ~~Controls~~ and hand showers shall comply with Sections 608.4 and 309.4.

**608.4.1 Transfer-type showers.** In transfer-type showers, the operable portion of controls and hand shower shall be located:

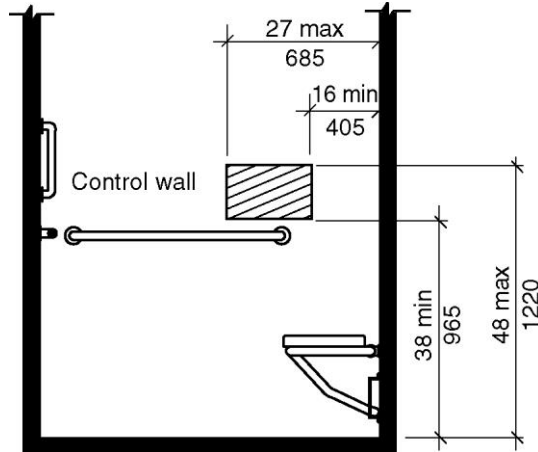
1. On the control wall opposite the seat.
2. At a height of 38 inches (965 mm) minimum and 48 inches (1220 mm) maximum above the shower floor, and
3. 15 inches (380 mm) maximum, from the centerline of the control wall toward the shower opening.



**FIGURE 608.4.1**  
**TRANSFER-TYPE SHOWER CONTROLS AND HAND SHOWER LOCATION**

**608.4.2 Standard roll-in showers.** In standard roll-in showers, the operable portion of controls and hand shower shall not be located above the seat. Controls and hand showers shall be located according to the following:

1. On the back wall,
2. At a height of 38 inches (965 mm) minimum and 48 inches (1220 mm) maximum above the shower floor and
3. 16 inches (405 mm) minimum and 27 inches (685 mm) maximum from the wall behind the seat.

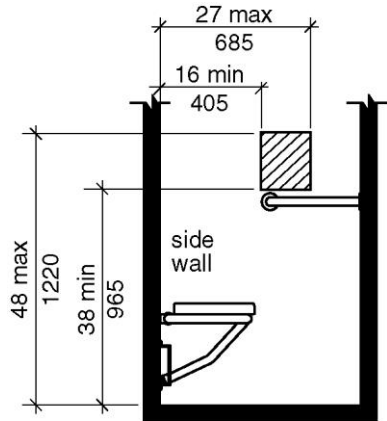


**FIGURE 608.4.2**  
**STANDARD ROLL-IN-TYPE SHOWER CONTROLS AND HAND SHOWER LOCATION**

**608.4.3 Alternate roll-in showers.** In alternate roll-in showers, the operable portion of controls and hand shower shall be located

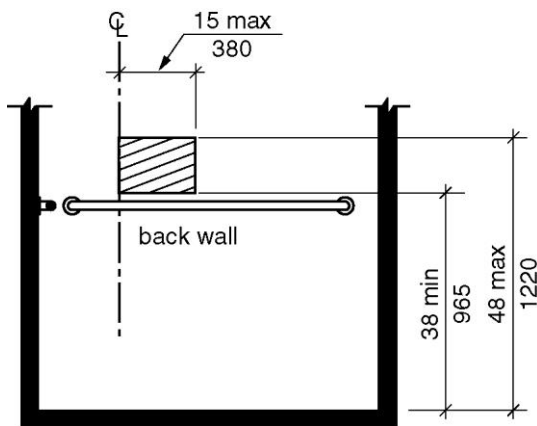
1. At a height of 38 inches (965 mm) minimum and 48 inches (1220 mm) maximum above the shower floor, and
2. Where the controls and hand shower are located on the end wall adjacent to the seat, the operable portion of controls and hand shower shall be 16 inches (405 mm) minimum and 27 inches (685 mm) maximum from the wall behind the seat wall, or

- Where the controls and hand shower are located on the back wall opposite the seat, the operable portion of controls and hand shower shall be located within 15 inches (380 mm) maximum from the centerline of the seat toward the transfer space.



(a)  
Side Wall  
(Elevation)

**FIGURE 608.4.3(A)**  
**ALTERNATE ROLL-IN-TYPE SHOWER CONTROLS AND HAND SHOWER**  
**LOCATION - END WALL – ELEVATION**



(b)  
Back Wall  
(Elevation)

**FIGURE 608.4.3(B)**  
**ALTERNATE ROLL-IN-TYPE SHOWER CONTROLS AND HAND SHOWER**  
**LOCATION - CONTROL WALL - ELEVATION**

**REASON:** This is somewhat a continuation of the discussions the committee has previously had regarding how the location of controls is to be done. The intent of this proposal is to provide

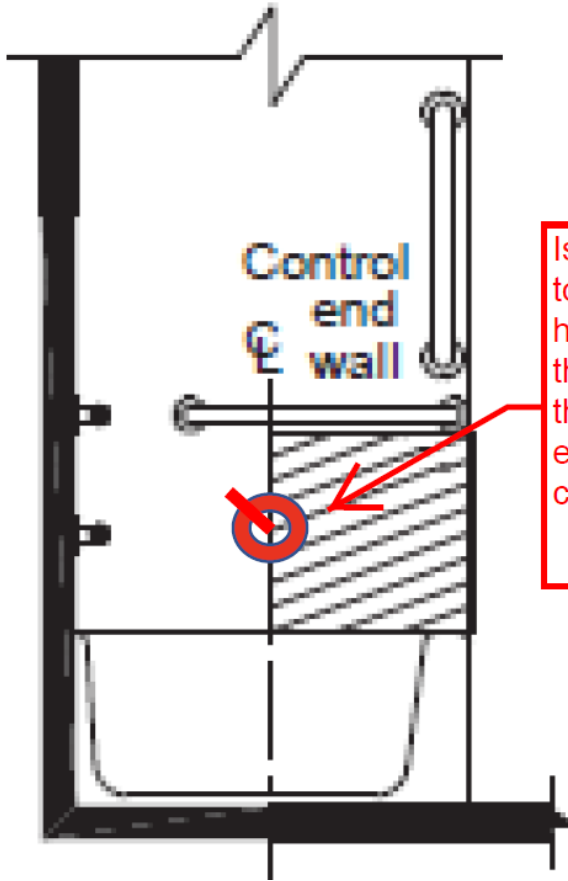
clarity and eliminate some of the debate or confusion that arises when the standard is not clearly stating the requirement. See the attached figures for some illustrations of the problem.

If a control is located at the centerline or slightly inside of the accepted space, is that adequate or because the handle of the control may rotate to be outside of the space does that make the control noncompliant? In addition, is the entire control expected to be within the space, or is it only the actual operable part of the control that must be located within the space? We have received inquiries from both designers and jurisdictions where a portion of a control – such as the trim piece behind the handle – extends outside of the designated location. While it could be argued that the trim piece is not the “control”, some people have viewed it as all being a part of the control element. And in the case of the lever faucet handle shown, is it only the pivot point that must be located within the space, or should either the entire length or a minimum length of the handle be expected to be entirely within the space?

Realistically when you look at the normal reach depths allowed by the standard, a 24-inch reach depth is permitted. When dealing with a typical 30 or 32 inch tub (or a 36” transfer shower) a control which is centered would still be within the reach range even if the operable portion of the handle spun outside of the designated control area shown within the standard. While the intent of having the control located toward the open side of the tub or shower is to permit someone to reach in and operate the control without getting wet, a control located at the centerline will typically make the same allowance and still will be located within the normally accepted reach range. From that standpoint this concern about whether the control is located completely within the designated space or not seems like much ado about nothing. However, where this issue comes up in the field, especially after the plumbing has been placed in the project, the lack of clarity within the standard causes a lot of unneeded debate.

This proposal does not argue that one option is correct or more appropriate, it simply is trying to clarify the requirement so that the language is applied more consistently and designers and enforcers have a better understanding of what the expectation is.

I elected to place the revised requirement for the showers into Section 608.4 so that it applied to all three types of showers instead of modifying each provision separately. Locating the requirement in Section 608.4 will apply to Item 3 of Section 608.4.1 for transfer showers, Item 3 of Section 608.4.2 for Standard roll-in showers, as well as Item 3 of Section 608.4.3 for alternate roll-in showers. If the committee prefers they could modify any or all of those three shower sections versus relying on a general section that would be applicable to all three shower types.



Is it OK for the control to be centered on the handle pivot, or is it the graspable part of the control that cannot extend beyond the centerline?



Committee Action: Disapproval 26-0-0

**REPORT OF HEARING:**

**Modification (if any):**

**Committee Reason:** The committee agreed that the replacement proposal to 06-47 will address issues in items 06-47, 06-48, 06-49, 06-51, 06-52, 06-66, 06-68.

**607.5 et al-PAARLBERG.doc**

<b>Report for 06-48- 2021</b>		
<i>Committee decision: D</i>	<i>Committee Vote at Meeting: 26-0-0</i>	<i>Committee Vote on Ballot:</i>
<b>REPORT OF HEARING:</b>		
Modification (if any):		
Committee Reason: The committee agreed that the replacement proposal to 06-47 will address issues in items 06-47, 06-48, 06-49, 06-51, 06-52, 06-66, 06-68.		
<b>PUBLIC COMMENT- FIRST DRAFT:</b>		
Proponent:		
Desired Action:		
Modification:		
Reason:		



<b>Report for 06-48- 2021</b>		
<i>Committee decision: AS/AM/D</i>	<i>Committee Vote at Meeting:</i>	<i>Committee Vote on Ballot:</i>
<b>REPORT OF HEARING – FIRST DRAFT</b>		
Modification (if any):		
Committee Reason:		
<b>PUBLIC COMMENT- SECOND DRAFT:</b>		
Proponent:		
Desired Action:		
Modification:		
Reason:		
<i>Committee decision: AS/AM/D</i>	<i>Committee Vote at Meeting:</i>	<i>Committee Vote on Ballot:</i>
<b>FINAL ACTION:</b>		
Modification (if any):		
Committee Reason:		

## 06-49 – 2021

### 607.5, 607.6, 609.3, Figures 607.6(A)(New), 607.6(B)(New)

**Proponent:** Kimberly Paarlberg, International Code Council

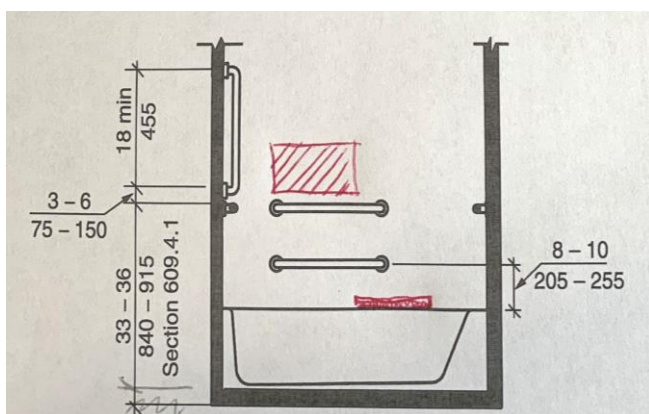
**Revise as follows:**

#### SECTION 607 BATHTUBS

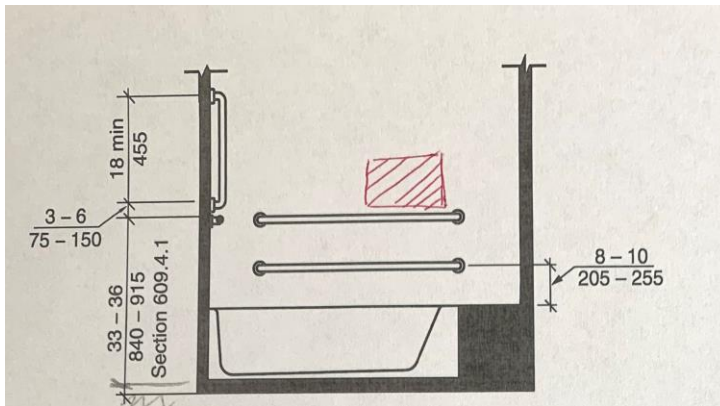
**607.5 Controls.** The on/off and temperature and diverter Controls, other than drain stoppers, shall be provided on an end wall, located between the bathtub rim and grab bar, and between the open side of the bathtub and the centerline of the width of the bathtub. Controls shall comply with Section 309.4.

**607.6 Hand shower.** A hand shower with a hose 59 inches (1500 mm) minimum in length, that can be used as both a fixed shower head and as a hand shower, shall be provided. The hand shower head shall have a control with a nonpositive shut-off feature. A means to hold the hand shower while in the on or off position shall be provided and located within the forward reach of the seat and at a height of 38 inches (965 mm) minimum and 48 inches (1220 mm) maximum above the tub floor. -Where provided, an adjustable-height hand shower mounted on a vertical bar shall be installed so as to not obstruct the use of grab bars. A fixed shower head, in addition to the hand shower shall be permitted.

**Exception:** Where the means to hold the hand shower head is adjustable on a vertical bar, the vertical bar is permitted to extend above 48 inches.



**FIGURE 607.6(A)**  
**HAND SHOWER LOCATION WITH REMOVABLE IN-TUB SEATS**



**FIGURE 607.6(B)**  
**HAND SHOWER LOCATION WITH SEATS AT HEAD END OF TUB**

**SECTION 609**  
**GRAB BARS**

**609.3 Spacing.** The space between the wall and the grab bar shall be 1½ inches (38 mm). The space between the grab bar and projecting objects below and at the ends of the grab bar shall be 1½ inches (38 mm) minimum. The space between the grab bar and projecting objects above the grab bar shall be 12 inches (305 mm) minimum.

**Exceptions:**

1. The space between the grab bars and shower/bathtub on/off and temperature controls, diverters, shower/bathtub fittings including the vertical bar for the adjustable means to hold the hand shower, and other grab bars above the grab bar shall be permitted to be 1½ inches (38 mm) minimum.
2. Recessed dispensers projecting from the wall ¼ inch (6.4 mm) maximum measured from the face of the dispenser and complying with Section 604.7 shall be permitted within the 12-inch (305 mm) space above and the 1½-inch (38 mm) spaces below and at the ends of the grab bar.

---

**REASON:** This is for bathtubs; there is a similar proposal for showers. The intent of this proposal is to 1) leave the controls in the current location; but allow additional options for the means to hold the hand shower within reach of the seat and 2) use consistent and precise terminology and 3) coordinate current requirements.

It is important that we are all using and understanding the terms in the same way -

The ‘on/off and temperature controls’, depending on the system chosen, can be one, two or three handles. This controls the water flow and the temperature of the water.

The ‘diverter’ is for situations where there is both a fixed shower head and a hand held shower. The diverter can also be used to change the water spray to a variety of devices, such as back sprays or tub spouts. I have spoken with a group of ICC plumbing experts on what would be involved for relocating the diverter or providing additional sets of controls. Basically the

response was extensive added plumbing behind the wall, or in some scenarios, cannot be done without options way past standard plumbing.

The hand shower consists of the 59” hose and the hand shower head. A means to turn the water on and off (non-positive shut off valve) is required on the shower head. The ‘means to hold the hand shower head’ can be a bracket on the wall or a sliding bracket on a vertical pole. The figures would be in addition to the current to show the options for the means to hold the hand shower head. The changes to 608.5 is to keep the information for hand showers in one location – currently we have it mixed up in both. The exception indicates that a slider bar can be used for adjustment. The changes to 609.3 is to clarify what ‘not obstruct the grab bar’ means.

Committee Action: Disapproval 25-0-0

**REPORT OF HEARING:**

**Modification (if any):**

**Committee Reason:** The committee agreed that the replacement proposal to 06-47 will address issues in items 06-47, 06-48, 06-49, 06-51, 06-52, 06-66, 06-68.

**607.5-PAARLBERG.doc**

<b>Report for 06-49– 2021</b>		
<i>Committee decision: D</i>	<i>Committee Vote at Meeting: 25-0-0</i>	<i>Committee Vote on Ballot:</i>
<b>REPORT OF HEARING:</b>		
Modification (if any):		
Committee Reason: The committee agreed that the replacement proposal to 06-47 will address issues in items 06-47, 06-48, 06-49, 06-51, 06-52, 06-66, 06-68.		
<b>PUBLIC COMMENT- FIRST DRAFT:</b>		
Proponent:		
Desired Action:		
Modification:		
Reason:		
<i>Committee decision: AS/AM/D</i>	<i>Committee Vote at Meeting:</i>	<i>Committee Vote on Ballot:</i>
<b>REPORT OF HEARING – FIRST DRAFT</b>		
Modification (if any):		
Committee Reason:		
<b>PUBLIC COMMENT- SECOND DRAFT:</b>		
Proponent:		
Desired Action:		
Modification:		
Reason:		
<i>Committee decision: AS/AM/D</i>	<i>Committee Vote at Meeting:</i>	<i>Committee Vote on Ballot:</i>
<b>FINAL ACTION:</b>		
Modification (if any):		
Committee Reason:		

## 06-50 – 2021

### 607.5, 607.6, Figure 607.5(B)(New)

**Proponent:** Doug Anderson, representing A117.1 Accessible Bathing Task Group

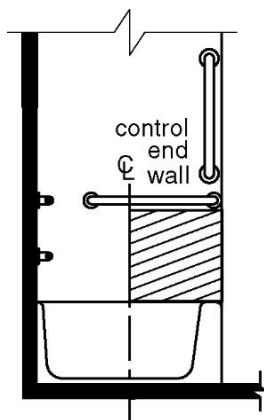
**Revise text as follows:**

#### SECTION 607 BATHTUBS

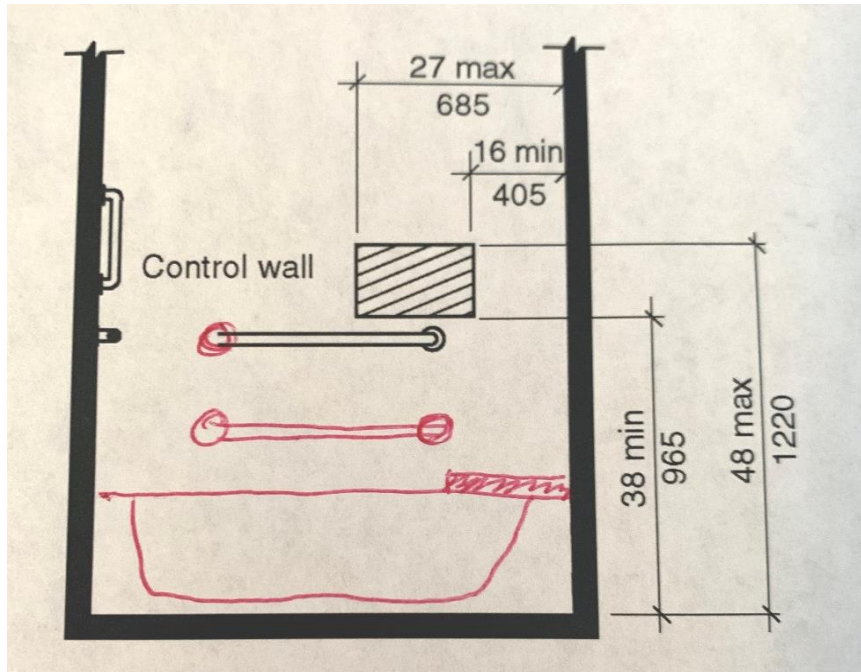
**607.5 Controls.** Controls, other than drain stoppers, shall be provided on an end wall, located between the bathtub rim and grab bar, and between the open side of the bathtub and the centerline of the width of the bathtub. Controls shall comply with Section 309.4.

**Exception:** In bathtubs with fixed folding in-tub seats where the mount for the hand shower complying with Section 607.6 is located on the back wall, the diverter for the hand shower shall be located according to the following:

1. On the back wall,
2. At a height of 38 inches (965 mm) minimum and 48 inches (1220 mm) maximum above the shower floor, and
3. 16 inches (405 mm) minimum and 27 inches (685 mm) maximum from the head wall behind the seat.



**FIGURE 607.5(A)**  
**LOCATION OF BATHTUB CONTROLS**



**FIGURE 607.5(B)**  
**EXCEPTION-LOCATION OF DIVERTER FOR BATHTUB WITH FIXED FOLDING**  
**IN-TUB SEAT**

**607.6 Hand shower.** A hand shower with a hose 59 inches (1500 mm) minimum in length, ~~that can be used as both a fixed shower head and as a hand shower,~~ shall be provided. A fixed mount or an adjustable-height mount on a vertical bar shall be provided so the hand shower can be used as both a fixed shower head and as a hand shower. The mount shall be on the back wall within reach of the seat or on the control wall. The hand shower shall have ~~a control with~~ a nonpositive shut-off feature. Where provided, an adjustable-height hand shower mounted on a vertical bar shall be installed so as to not obstruct the use of grab bars.

**REASON:** The industry is installing fixed folding in-tub seats and is proposing language to provide specifications for an optional location for diverter for a hand shower. The photos are to illustrate what type of seat this proposal is talking about. This photo shows how the current requirements make the hand shower impossible to reach from the seat.

The intent of this proposal is to allow for the mount to hold the hand shower, the hand shower and the diverter to move the water to the hand shower the option of being located on the back wall.

The clarification in Section 607.6 would be beneficial for all 3 types of bathtubs with seats.



**Staff Note:** This proposal is from the A117.1 Accessible Bathing Task Group. Proposals 06-41, 06-42, 06-45, 06-50 and 06-81 are all related to bathtubs with a fixed folding in-tub seat.

Committee Action: Disapproval 24-3-0

**REPORT OF HEARING:**

**Modification (if any):**

**Committee Reason:** Proposals 06-41, 06-42, 06-45, 06-50 and 06-81 are all related to bathtubs. Modifications to 06-41, 06-42 and 06-45 will replace the 5 proposal (separated by section) with 3 proposals (separated to one for each type of bathtub seat configuration).

This proposal was disapproved based on the committee actions for 06-41, 06-42 and 06-45.

**607.5-ANDERSON.doc**

<b>Report for 06-50- 2021</b>		
<b>Committee decision:</b> D	<b>Committee Vote at Meeting:</b> 24-3-0	<b>Committee Vote on Ballot:</b>
<b>REPORT OF HEARING:</b>		
Modification (if any):		
Committee Reason: Proposals 06-41, 06-42, 06-45, 06-50 and 06-81 are all related to bathtubs. Modifications to 06-41, 06-42 and 06-45 will replace the 5 proposal (separated by section) with 3 proposals (separated to one for each type of bathtub seat configuration).		
This proposal was disapproved based on the committee actions for 06-41, 06-42 and 06-45.		
<b>PUBLIC COMMENT- FIRST DRAFT:</b>		
Proponent:		
Desired Action:		
Modification:		
Reason:		
<b>Committee decision:</b> AS/AM/D	<b>Committee Vote at Meeting:</b>	<b>Committee Vote on Ballot:</b>
<b>REPORT OF HEARING – FIRST DRAFT</b>		
Modification (if any):		
Committee Reason:		
<b>PUBLIC COMMENT- SECOND DRAFT:</b>		
Proponent:		
Desired Action:		
Modification:		
Reason:		
<b>Committee decision:</b> AS/AM/D	<b>Committee Vote at Meeting:</b>	<b>Committee Vote on Ballot:</b>
<b>FINAL ACTION:</b>		
Modification (if any):		
Committee Reason:		





## 06-51 – 2021 607.5, 608.4

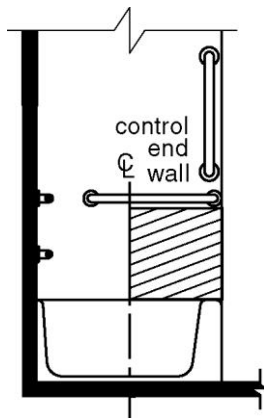
**Proponent:** Ed Steinfeld, IDEA Center, University of Buffalo representing RESNA

**Revise text as follows:**

### SECTION 607 BATHTUBS

**607.5 Controls.** Controls, other than drain stoppers, shall be provided on an end wall, located between the bathtub rim and grab bar, and between the open side of the bathtub and the centerline of the width of the bathtub. Controls shall comply with Section 309.4.

**Exception:** Shut off features are permitted to be located outside the designated control area.



**FIGURE 607.5  
LOCATION OF BATHTUB CONTROLS**

### SECTION 608 SHOWER COMPARTMENTS

**608.4 Controls and hand showers.** Controls and hand showers shall comply with Sections 608.4 and 309.4.

**Exception:** Shut off features are permitted to be located outside the designated control area.

---

**REASON:** In the field, the shut off valve on hand held showers are being interpreted as controls that have to be located within the control area.

---

## 06-51 – 2021 Replacement Modification 607.5, 608.4

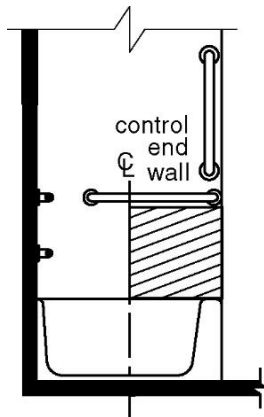
**Proponent:** Ed Steinfeld, IDEA Center, University of Buffalo representing RESNA

**Replace text as follows:**

## **SECTION 607 BATHTUBS**

**607.5 Controls.** Controls, other than drain stoppers, shall be provided on an end wall, located between the bathtub rim and grab bar, and between the open side of the bathtub and the centerline of the width of the bathtub. Controls shall comply with Section 309.4.

**Exception:** Non-positive shut off features on hand showers complying with Section 607.6 are not required to be located in the control area.



**FIGURE 607.5  
LOCATION OF BATHTUB CONTROLS**

## **SECTION 608 SHOWER COMPARTMENTS**

**608.4 Controls and hand showers.** Controls and hand showers shall comply with Sections 608.4 and 309.4.

**Exception:** Non-positive shut off features on hand showers complying with Section 608.5 are not required to be located in the control area.

Reason: The modification clarifies that the proposal is only about shut off valves that are part of a hand-held shower device. When a hand-held shower is provided with a shut off valve at the head it is literally in the users hand so it is within reach. This is an economic issue. In affordable housing, the simplest way to provide a shut off valve is to incorporate it within the shower head or right below it on the hose. Currently, this is not allowed. Without the exception, shut off valves will not be incorporated into accessible units in affordable housing. This also makes it easier to include shut off valves in renovations, including those that are intended to redress non-compliance with the standard.



. [https://www.amazon.com/Faucet-Single-Spray-Touch-Clean-Shower-59462-B-PK/dp/B006FYBI92/ref=dp\\_prsubs\\_2?pd\\_rd\\_i=B006FYBI92&th=1](https://www.amazon.com/Faucet-Single-Spray-Touch-Clean-Shower-59462-B-PK/dp/B006FYBI92/ref=dp_prsubs_2?pd_rd_i=B006FYBI92&th=1)

Committee Action: Disapproved 25-1-0

**REPORT OF HEARING:**

**Modification (if any):**

**Committee Reason:** This proposal was disapproved based on previous action on 06-47. In 06-47 the hand shower and shut off valve are addressed separately from controls to turn the water on and off for the tub or shower.

607.5-STEINFELD.doc

<b>Report for 06-51– 2021</b>		
<b>Committee decision:</b> D	<b>Committee Vote at Meeting:</b> 25-1-0	<b>Committee Vote on Ballot:</b>
<b>REPORT OF HEARING:</b>		
Modification (if any):		
Committee Reason: This proposal was disapproved based on previous action on 06-47. In 06-47 the hand shower and shut off valve are addressed separately from controls to turn the water on and off for the tub or shower.		
<b>PUBLIC COMMENT- FIRST DRAFT:</b>		
Proponent:		
Desired Action:		
Modification:		
Reason:		
<b>Committee decision:</b> AS/AM/D	<b>Committee Vote at Meeting:</b>	<b>Committee Vote on Ballot:</b>
<b>REPORT OF HEARING – FIRST DRAFT</b>		
Modification (if any):		
Committee Reason:		
<b>PUBLIC COMMENT- SECOND DRAFT:</b>		
Proponent:		
Desired Action:		
Modification:		
Reason:		
<b>Committee decision:</b> AS/AM/D	<b>Committee Vote at Meeting:</b>	<b>Committee Vote on Ballot:</b>
<b>FINAL ACTION:</b>		
Modification (if any):		
Committee Reason:		

## 06-52 – 2021 607.6, 608.5

**Proponent:** Kyle Thompson, Plumbing Manufacturers International (PMI)

**Revise as follows:**

### SECTION 607 BATHTUBS

**607.6 Hand ~~shower~~ showers.** A hand shower with a hose 59 inches (1500 mm) minimum in length, that can be used as both a fixed shower head and as a hand shower, shall be provided. The hand shower shall have a control with a nonpositive shutoff feature. Where provided, an adjustable-height hand shower mounted on a vertical bar shall be permitted to be installed within 12 inches above so as to not obstruct the use of horizontal grab bars. A means to hold the hand shower while in the on or off position shall be located at a height of 38 inches (965 mm) minimum and 48 inches (1220 mm) maximum above the bottom of the bathtub, and the hand shower shall be located within reach of the seat.

**Exceptions:**

1. Where a vertical bar is used to hold a hand shower, the vertical bar shall be permitted to extend above 48 inches (1220 mm). The device to adjust the height of the hand shower shall not be required to comply with Section 309.
2. In other than Accessible units and Type A units, a fixed shower head located not greater than 48 inches (1220 mm) above the bottom of the bathtub shall be permitted in lieu of a hand shower.

### SECTION 608 SHOWER COMPARTMENT

**608.5 Hand showers.** A hand shower with a hose 59 inches (1500 mm) minimum in length, that can be used both as a fixed shower head and as a hand shower, shall be provided. The hand shower shall have a control with a nonpositive shutoff feature. Where provided, an adjustable-height hand shower mounted on a vertical bar shall be permitted to be installed within 12 inches above so as to not obstruct the use of horizontal grab bars. A means to hold the hand shower ~~and~~ while in the on or off position shall be located at a height of 38 inches (965 mm) minimum and 48 inches (1220 mm) maximum above the shower finish floor, and the hand shower shall be located within reach of the seat.

**Exception Exceptions:**

1. Where a vertical bar is used to hold a hand shower, the vertical bar shall be permitted to extend above 48 inches (1220 mm). The device to adjust the height of the hand shower shall not be required to comply with Section 309.
2. In other than Accessible units and Type A units, a fixed shower head located not greater than 48 inches (1220 mm) ~~maximum~~ above the shower floor shall be permitted in lieu of a hand shower.

---

**REASON:** Consistency in hand shower requirements is being applied to both tubs and showers in Sections 607.6 and 608.5. The requirement to install a hand shower between 38 and 48 inches would cause a hand shower to be considered as an obstruction with horizontal grab bars. Therefore, the need to add text to Sections 607.6 and 608.5 to allow the vertical bar to be installed within 12 inches above horizontal grab bars in accordance with Section 609.3. Additionally, a new requirement is being added to mandate that the means to hold the hand shower be located within reach of a tub or shower seat without being required to be located in the same box as temperature, on or-off flow and shower diversion controls. Furthermore, the new exception permits a hand shower to be used as either a fixed shower or hand shower. This allows for hand showers to be used in universal designs.

---

## **06-52 – 2021 Replacement modification**

### **607.6, 608.5**

**Proponent:** Kyle Thompson, Plumbing Manufacturers International (PMI)

**Replace and revise as follows:**

#### **SECTION 607**

#### **BATHTUBS**

**607.6 Hand shower showers.** A hand shower with a hose 59 inches (1500 mm) minimum in length, that can be used as both a fixed shower head and as a hand shower, shall be provided. The hand shower shall have a control with a nonpositive shutoff feature. A mount to hold the hand shower while in the on or off position shall be located at a height of 38 inches (965 mm) minimum and 48 inches (1220 mm) maximum above the bottom of the bathtub, and shall be located within reach of the seat. Where provided, an adjustable-height ~~hand shower mounted mount~~ on a vertical bar for the hand shower shall be installed so as to not obstruct the use of grab bars.

**Exceptions:**

1. Where a vertical bar supports an adjustable height mount, the vertical bar shall be permitted to extend above 48 inches (1220 mm). The device to adjust the height of the hand shower mount shall not be required to comply with Section 309.2 or 309.3.
2. In other than Accessible units and Type A units, a fixed shower head located not greater than 48 inches (1220 mm) above the bottom of the bathtub shall be permitted in lieu of a hand shower.

#### **SECTION 608**

#### **SHOWER COMPARTMENT**

**608.5 Hand showers.** A hand shower with a hose 59 inches (1500 mm) minimum in length, that can be used both as a fixed shower head and as a hand shower, shall be provided. The hand

shower shall have a control with a nonpositive shutoff feature. ~~Where provided, an adjustable-height hand shower mounted on a vertical bar shall be installed so as to not obstruct the use of grab bars.~~ A ~~means~~ mount to hold the hand shower while in the on or off position shall be located at a height of 38 inches (965 mm) minimum and 48 inches (1220 mm) maximum above the shower finish floor, and shall be located within reach of the seat. Where provided, an adjustable-height mount on a vertical bar for the hand shower shall be installed so as to not obstruct the use of grab bars.

**Exception Exceptions:**

1. Where a vertical bar is used to hold a hand shower, the vertical bar shall be permitted to extend above 48 inches (1220 mm). The device to adjust the height of the hand shower shall not be required to comply with Sections 309.2 or 309.3.
2. In other than Accessible units and Type A units, a fixed shower head located not greater than 48 inches (1220 mm) ~~maximum~~ above the shower floor shall be permitted in lieu of a hand shower.

**SECTION 609  
GRAB BARS**

**609.3 Spacing.** The space between the wall and the grab bar shall be 11/2 inches (38 mm). The space between the grab bar and projecting objects below and at the ends of the grab bar shall be 11/2 inches (38 mm) minimum. The space between the grab bar and projecting objects above the grab bar shall be 12 inches (305 mm) minimum.

**Exceptions:**

1. The space between the grab bars and shower controls, shower fittings, vertical bars and mounts used to hold hand showers, and other grab bars above the grab bar shall be permitted to be 1-1/2 inches (38 mm) minimum.
2. Recessed dispensers projecting from the wall 1/4 inch (6.4 mm) maximum measured from the face of the dispenser and complying with Section 604.7 shall be permitted within the 12-inch (305 mm) space above and the 11/2-inch (38 mm) spaces below and at the ends of the grab bar.

---

**REASON:** Requirements in tubs and showers should be the same. Requirements currently in showers has been moved into tubs.

The intent of the modifications are for clarification of the requirements for hand showers and the mounts they sit on. The language often says ‘hand shower’ when it means the mount to hold the hand shower.

Added clarifications are:

- that the mount has to be within reach of the seat
- the elements that allow for a mount for the shower head can be close to the grab bar to facilitate reach;
- the slide on the vertical grab bar can be moved up so that the hand shower can also serve as a standard fixed head shower

Committee Action: Disapproval 25-0-0

**REPORT OF HEARING:**

**Modification (if any):**

**Committee Reason:** The committee agreed that the replacement proposal to 06-47 will address issues in items 06-47, 06-48, 06-49, 06-51, 06-52, 06-66, 06-68.

**607.6 THOMPSON.doc**

<b>Report for 06-52– 2021</b>		
<b>Committee decision: D</b>	<b>Committee Vote at Meeting: 25-0-0</b>	<b>Committee Vote on Ballot:</b>
<b>REPORT OF HEARING:</b>		
Modification (if any):		
Committee Reason: The committee agreed that the replacement proposal to 06-47 will address issues in items 06-47, 06-48, 06-49, 06-51, 06-52, 06-66, 06-68.		
<b>PUBLIC COMMENT- FIRST DRAFT:</b>		
Proponent:		
Desired Action:		
Modification:		
Reason:		
<b>Committee decision: AS/AM/D</b>	<b>Committee Vote at Meeting:</b>	<b>Committee Vote on Ballot:</b>
<b>REPORT OF HEARING – FIRST DRAFT</b>		
Modification (if any):		
Committee Reason:		
<b>PUBLIC COMMENT- SECOND DRAFT:</b>		
Proponent:		
Desired Action:		
Modification:		
Reason:		
<b>Committee decision: AS/AM/D</b>	<b>Committee Vote at Meeting:</b>	<b>Committee Vote on Ballot:</b>
<b>FINAL ACTION:</b>		
Modification (if any):		
Committee Reason:		

## 06-53 – 2021

### 607.6, 608.5

**Proponent:** Kimberly Paarlberg, International Code Council

**Revise as follows:**

#### SECTION 607 BATHTUBS

**607.6 Hand shower.** A hand shower with a hose 59 inches (1500 mm) minimum in length, that can be used as both a fixed shower head and as a hand shower, shall be provided. The hand shower shall have a control with a nonpositive shutoff feature. Where provided, an adjustable-height hand shower mounted on a vertical bar shall be installed so as to not obstruct the use of grab bars.

**Exceptions:**

1. In other than Accessible units and Type A units, a fixed shower head located not greater than 48 inches (1220 mm) above the bottom of the bathtub shall be permitted in lieu of a hand shower.
2. In Accessible units, a fixed shower head located at not greater than 48 inches (1220 mm) above the tub floor shall be permitted in lieu of a hand shower where the clinical needs of a person receiving care or security concerns would consider the shower hose a safety hazard.

#### SECTION 608 SHOWER COMPARTMENT

**608.5 Hand showers.** A hand shower with a hose 59 inches (1500 mm) minimum in length, that can be used both as a fixed shower head and as a hand shower, shall be provided. The hand shower shall have a control with a nonpositive shutoff feature. Where provided, an adjustable-height hand shower mounted on a vertical bar shall be installed so as to not obstruct the use of grab bars. A means to hold the hand shower ~~wand~~ while in the on or off position shall be located at a height of 38 inches (965 mm) minimum and 48 inches (1220 mm) maximum above the shower finish floor.

**Exception Exceptions:**

1. In other than Accessible units and Type A units, a fixed shower head located not greater than 48 inches (1220 mm) maximum above the shower floor shall be permitted in lieu of a hand shower.
2. In Accessible units, a fixed shower head located at not greater than 48 inches (1220 mm) above the tub floor shall be permitted in lieu of a hand shower where the clinical needs of a person receiving care or security concerns would consider the shower hose a safety hazard.

---

**REASON:** This proposal has two points.



The first exception in 607.5 is intended to be consistent between the current exception in 608.5. The fixed head should be an option in tubs or showers.

The second exception in 607.5 and 608.5 is in consideration of suicide prevention and security concerns in some hospitals and jails (which require Accessible units). I found several studies indicating that suicides are the number one cause of deaths in jails. In addition, there is a concern that the hose could be ripped out of the wall and used as some kind of weapon.

---

## **06-53 – 2021 modification**

### **607.6, 608.5**

**Proponent:** Marsha Mazz, United Spinal Assoc.

**Further revise as follows:**

#### **SECTION 607 BATHTUBS**

**607.6 Hand shower.** A hand shower with a hose 59 inches (1500 mm) minimum in length, that can be used as both a fixed shower head and as a hand shower, shall be provided. The hand shower shall have a control with a nonpositive shutoff feature. Where provided, an adjustable-height hand shower mounted on a vertical bar shall be installed so as to not obstruct the use of grab bars.

**Exceptions:**

1. In other than Accessible units and Type A units, a fixed shower head located not greater than 48 inches (1220 mm) above the bottom of the bathtub shall be permitted in lieu of a hand shower.
2. In Accessible units, a fixed shower head located at not greater than 48 inches (1220 mm) above the tub floor shall be permitted in lieu of a hand shower where the clinical needs of a person receiving care or security concerns would consider the shower hose a safety hazard toilet or bathing room is specially designed without protrusions for purposes of suicide prevention.

#### **SECTION 608 SHOWER COMPARTMENT**

**608.5 Hand showers.** A hand shower with a hose 59 inches (1500 mm) minimum in length, that can be used both as a fixed shower head and as a hand shower, shall be provided. The hand shower shall have a control with a nonpositive shutoff feature. Where provided, an adjustable-height hand shower mounted on a vertical bar shall be installed so as to not obstruct the use of grab bars. A means to hold the hand shower ~~wand~~ while in the on or off position shall be located at a height of 38 inches (965 mm) minimum and 48 inches (1220 mm) maximum above the shower finish floor.

**Exceptions:**

1. In other than Accessible units and Type A units, a fixed shower head located not greater than 48 inches (1220 mm) above the shower floor shall be permitted in lieu of a hand shower.
2. In Accessible units, a fixed shower head located at not greater than 48 inches (1220 mm) above the tub floor shall be permitted in lieu of a hand shower where the ~~clinical needs of a person receiving care or security concerns would consider the shower hose a safety hazard~~ toilet or bathing room is specially designed without protrusions for purposes of suicide prevention.

Reason: Proposed Exception 2 requires the enforcing authority to “know” when a specific person’s “clinical needs” warrant concern regarding potential suicide. Not only is there no way for a code official to make this determination, but it is also unlikely that the prospective occupant of the unit will be: (1) known at the time of construction, and (2) a permanent resident, thereby necessitating reevaluation when the occupant changes. Further, Accessible units are scoped for both transient lodging and institutional occupancies. I don’t think we can assume that every occupant of an Accessible space has “clinical needs”.

Unlike proposed Exception 2, the modification provides visible and unambiguous criteria for determining where the exception for suicide concerns applies using language from a current exception in the Standard that addresses the same concern related to grab bars, Exception 2 to § 604, which is based on Exception 3 to § 604.5 of the 2010 ADA Standards.

We have NOT included the portion of the exception meant to address “security concerns” because we are not convinced that these are significant issues in transient lodging and institutional occupancies. Furthermore, an Exception in the 2010 ADA Standards to §608.6 allows a fixed shower head in all bathing facilities EXCEPT: “medical care facilities, long-term care facilities, transient lodging guest rooms, or residential dwelling units”. Consequently, the proposed exception applied to Accessible units would directly conflict with the ADA Standards and, in practicality, could not be used.

## **BACKGROUND INFORMATION:**

### **2017 ICC A117.1**

**604.5 Grab bars.** Grab bars for water closets shall comply with Section 609 and shall be provided in accordance with Sections 604.5.1 and 604.5.2. Grab bars shall be provided on the rear wall and on the side wall closest to the water closet.

**Exceptions: 1.** Grab bars shall not be required to be installed in a toilet room for a single occupant, accessed only through a private office and not for common use or public use, provided reinforcement has been installed in walls and located so as to permit the installation of grab bars complying with Section 604.5.

2. In detention or correction facilities, grab bars shall not be required to be installed in housing or holding cells or rooms that are specially designed without protrusions for purposes of suicide prevention.

## **2010 ADA Standards**

### **608.6 Shower Spray Unit and Water**

A shower spray unit with a hose 59 inches (1500 mm) long minimum that can be used both as a fixed-position shower head and as a hand-held shower shall be provided. The shower spray unit shall have an on/off control with a non-positive shut-off. If an adjustable-height shower head on a vertical bar is used, the bar shall be installed so as not to obstruct the use of grab bars. Shower spray units shall deliver water that is 120°F (49°C) maximum.

**EXCEPTION:** A fixed shower head located at 48 inches (1220 mm) maximum above the shower finish floor shall be permitted instead of a hand-held spray unit in facilities that are not medical care facilities, long-term care facilities, transient lodging guest rooms, or residential dwelling units.

Committee Action: Approval as Modified 21-2-2

### **REPORT OF HEARING:**

**Modification (if any):** Per the modification indicated above.

Further modify as follows:

## **SECTION 607 BATHTUBS**

**607.6 Hand shower.** A hand shower with a hose 59 inches (1500 mm) minimum in length, that can be used as both a fixed shower head and as a hand shower, shall be provided. The hand shower shall have a control with a nonpositive shutoff feature. Where provided, an adjustable-height hand shower mounted on a vertical bar shall be installed so as to not obstruct the use of grab bars.

### **Exceptions:**

3. In other than Accessible units and Type A units, a fixed shower head located not greater than 48 inches (1220 mm) above the bottom of the bathtub shall be permitted in lieu of a hand shower.
4. In Accessible units, a fixed shower head located at not greater than 48 inches (1220 mm) above the tub floor shall be permitted in lieu of a hand shower where the ~~clinical needs of a person receiving care or security concerns would consider the shower hose a safety hazard~~ toilet or bathing room is specially designed without protrusions for purposes of suicide prevention.

## **SECTION 608 SHOWER COMPARTMENT**

**608.5 Hand showers.** A hand shower with a hose 59 inches (1500 mm) minimum in length, that can be used both as a fixed shower head and as a hand shower, shall be provided. The hand shower shall have a control with a nonpositive shutoff feature. Where provided, an adjustable-height hand shower mounted on a vertical bar shall be installed so as to not obstruct the use of grab bars. A means to hold the hand shower ~~wand~~ while in the on or off position shall be located at a height of 38 inches (965 mm) minimum and 48 inches (1220 mm) maximum above the shower finish floor.

**Exceptions:**

3. In other than Accessible units and Type A units, a fixed shower head located not greater than 48 inches (1220 mm) above the shower floor shall be permitted in lieu of a hand shower.
4. In Accessible units, a fixed shower head located at not greater than 48 inches (1220 mm) above the tub floor shall be permitted in lieu of a hand shower where the ~~clinical needs of a person receiving care or security concerns would consider the shower hose a safety hazard~~ toilet or bathing room is specially designed without protrusions for purposes of suicide prevention.

**Committee Reason:** The addition of the exception for a fixed shower head in bathtubs is coordinating with the same allowance in showers and is needed to address locations where the chance of vandalism is high. This may need to be coordinated with the allowance for seats on the head wall in the replacement to 06-45.

The new exception for locations where there may be concerns for resident safety is needed in areas such as psych wards or dementia wards in hospitals and suicide watch areas in jails. The modification was for consistency with the terminology used in Section 604.5.

**607.6 THOMPSON.doc**

<b>Report for 06-53- 2021</b>		
<i>Committee decision: AS/AM/D</i>	<i>Committee Vote at Meeting:</i>	<i>Committee Vote on Ballot:</i>
<p><b>REPORT OF HEARING:</b> Modification (if any): <b>Further revise as follows:</b></p>		
<p><b>SECTION 607 BATHTUBS</b></p>		
<p><b>607.6 Hand shower.</b> A hand shower with a hose 59 inches (1500 mm) minimum in length, that can be used as both a fixed shower head and as a hand shower, shall be provided. The hand shower shall have a control with a nonpositive shutoff feature. Where provided, an adjustable-height hand shower mounted on a vertical bar shall be installed so as to not obstruct the use of grab bars.</p> <p><b>Exceptions:</b></p> <ol style="list-style-type: none"> <li>1. In other than Accessible units and Type A units, a fixed shower head located not greater than 48 inches (1220 mm) above the bottom of the bathtub shall be permitted in lieu of a hand shower.</li> <li>2. In Accessible units, a fixed shower head located at not greater than 48 inches (1220 mm) above the tub floor shall be permitted in lieu of a hand shower where the <del>clinical needs of a person receiving care or security concerns would consider the shower hose a safety hazard</del> toilet or bathing room is specially designed without protrusions for purposes of suicide prevention.</li> </ol>		
<p><b>SECTION 608 SHOWER COMPARTMENT</b></p>		
<p><b>608.5 Hand showers.</b> A hand shower with a hose 59 inches (1500 mm) minimum in length, that can be used both as a fixed shower head and as a hand shower, shall be provided. The hand shower shall have a control with a nonpositive shutoff feature. Where provided, an adjustable-height hand shower mounted on a vertical bar shall be installed so as to not obstruct the use of grab bars. A means to hold the hand shower <del>wand</del> while in the on or off position shall be located at a height of 38 inches (965 mm) minimum and 48 inches (1220 mm) maximum above the shower finish floor.</p> <p><b>Exceptions:</b></p> <ol style="list-style-type: none"> <li>1. In other than Accessible units and Type A units, a fixed shower head located not greater than 48 inches (1220 mm) above the shower floor shall be permitted in lieu of a hand shower.</li> <li>2. In Accessible units, a fixed shower head located at not greater than 48 inches (1220 mm) above the tub floor shall be permitted in lieu of a hand shower where the <del>clinical needs of a person receiving care or security concerns would consider the shower hose a safety hazard</del> toilet or bathing room is specially designed without protrusions for purposes of suicide prevention.</li> </ol>		
<p><b>Committee Reason:</b> The addition of the exception for a fixed shower head in bathtubs is coordinating with the same allowance in showers and is</p>		

**Report for 06-53– 2021**

needed to address locations where the chance of vandalism is high. This may need to be coordinated with the allowance for seats on the head wall in the replacement to 06-45.

The new exception for locations where there may be concerns for resident safety is needed in areas such as psych wards or dementia wards in hospitals and suicide watch areas in jails. The modification was for consistency with the terminology used in Section 604.5.

**PUBLIC COMMENT- FIRST DRAFT:**

Proponent:

Desired Action:

Modification:

Reason:

**Committee decision: AS/AM/D**

**Committee Vote at Meeting:**

**Committee Vote on Ballot:**

**REPORT OF HEARING – FIRST DRAFT**

Modification (if any):

Committee Reason:

**PUBLIC COMMENT- SECOND DRAFT:**

Proponent:

Desired Action:

Modification:

Reason:

**Committee decision: AS/AM/D**

**Committee Vote at Meeting:**

**Committee Vote on Ballot:**

**FINAL ACTION:**

Modification (if any):

Committee Reason:

## 06-54 – 2021

### 607.6

**Proponent:** Hope Reed, ADA Accessibility Consultant, representing self

**Revise as follows:**

#### SECTION 607 BATHTUBS

**607.6 Hand shower.** A hand shower with a hose 59 inches (1500mm) minimum in length, that can be used both as a fixed shower head and as a hand shower, shall be provided. The hand shower shall have a control with a nonpositive shut-off feature that complies with Section 309.4. Where provided, an adjustable-height hand shower mounted on a vertical bar shall be installed so as to not obstruct the use of grab bars. The hand shower wand shall be configured to allow adjustment of the water spray direction and limit rotation during use.

---

**REASON:** The hose for hand shower wands is usually twisted and when water pressure comes on it becomes even more twisted. When the spray wand is attached to a vertical bar and water is turned, it may rotate even further within the mounting. Often the spray wand ends up spraying in only one direction from its attachment. A person with disabilities who stands while showering may have to hover in the back corner and get only a small, small portion of the spray, or they may have to stand where they can block the water from spraying out into the room. A holder and handle need to fit without allowing rotation. *See alternate proposal we provided with 607.6(b).*

Committee Action: The proposal was split between the revisions to the 2<sup>nd</sup> and the new 4<sup>th</sup> sentence.

Part 1 – Revision to 2<sup>nd</sup> sentence – AS 11-9-1

Part 2 – Addition of 4<sup>th</sup> sentence – D 20-3-0

#### REPORT OF HEARING:

##### Modification (if any):

##### Replace with the following:

**607.6 Hand shower.** A hand shower with a hose 59 inches (1500mm) minimum in length, that can be used both as a fixed shower head and as a hand shower, shall be provided. The hand shower shall have a control with a nonpositive shut-off feature that complies with Section 309.4. Where provided, an adjustable-height hand shower mounted on a vertical bar shall be installed so as to not obstruct the use of grab bars.

**Committee Reason:** The committee felt that it was appropriate to ask for a non-positive shut off valve to meet Section 309.4 instead of all of Section 309 since the shower head is intended to be

hand held and not fixed. There was a discussion about if specific provisions over ride general requirements or not. The intent is that the more specific provisions would override the general provisions for operable parts (i.e., clear floor space, reach, and operation).

The addition of the last sentence was disapproved because the committee felt that the language was too open for interpretation and unenforceable.

**607.6(a)-REED.doc**

<b>Report for 06-54- 2021</b>		
<b>Committee decision: AS &amp; D</b>	<b>Committee Vote at Meeting: 11-9-1 &amp; 20-3-0</b>	<b>Committee Vote on Ballot:</b>
<b>REPORT OF HEARING:</b>		
Modification (if any):		
<b>Replace with the following:</b>		
<b>607.6 Hand shower.</b> A hand shower with a hose 59 inches (1500mm) minimum in length, that can be used both as a fixed shower head and as a hand shower, shall be provided. The hand shower shall have a control with a nonpositive shut-off feature <u>that complies with Section 309.4</u> . Where provided, an adjustable-height hand shower mounted on a vertical bar shall be installed so as to not obstruct the use of grab bars.		
Committee Reason: The committee felt that it was appropriate to ask for a non-positive shut off valve to meet Section 309.4 instead of all of Section 309 since the shower head is intended to be hand held and not fixed. ). There was a discussion about if specific provisions over ride general requirements or not. The intent is that the more specific provisions would override the general provisions for operable parts (i.e., clear floor space, reach, and operation.		
The addition of the last sentence was disapproved because the committee felt that the language was too open for interpretation and unenforceable.		
<b>PUBLIC COMMENT- FIRST DRAFT:</b>		
Proponent:		
Desired Action:		
Modification:		
Reason:		
<b>Committee decision: AS/AM/D</b>	<b>Committee Vote at Meeting:</b>	<b>Committee Vote on Ballot:</b>
<b>REPORT OF HEARING – FIRST DRAFT</b>		
Modification (if any):		
Committee Reason:		
<b>PUBLIC COMMENT- SECOND DRAFT:</b>		
Proponent:		
Desired Action:		
Modification:		
Reason:		
<b>Committee decision: AS/AM/D</b>	<b>Committee Vote at Meeting:</b>	<b>Committee Vote on Ballot:</b>
<b>FINAL ACTION:</b>		
Modification (if any):		
Committee Reason:		

# 06-55 – 2021

## 607.6

**Proponent:** Hope Reed, ADA Accessibility Consultant, representing self

**Revise as follows:**

### SECTION 607 BATHTUBS

**607.6 Hand shower.** A hand shower with a hose 59 inches (1500mm) minimum in length, that can be used both as a fixed shower head and as a hand shower, shall be provided. The hand shower shall have a control with a nonpositive shut-off feature. Where provided, an adjustable-height hand shower mounted on a vertical bar shall be installed so as to not obstruct the use of grab bars. The hand shower mount shall require the hand shower water spray to be directed without rotating during use and shall be located according to the following:

1. On the back wall,
2. At a height of 38 inches (965 mm) minimum and 48 inches (1220 mm) maximum above the shower floor and
3. 16 inches (405 mm) minimum and 27 inches (685 mm) maximum from the wall behind the seat.

**REASON:** The hose for hand shower wands is usually twisted and when water pressure comes on it becomes even more twisted. When the spray wand is attached to a vertical bar and water is turned, it may rotate even further within the mounting. Often the spray wand ends up spraying in only one direction from its attachment. A person with disabilities who stands while showering may have to hover in the back corner and get only a small, small portion of the spray, or they may have to stand where they can block the water from spraying out into the room. A holder and handle need to *fit* without allowing rotation. *See alternate proposal we provided with 607.6(a).*

Staff Note: 06-55 and 06-70 were both dispensed with one vote.

Committee Action: Disapproved 29-3-1

### REPORT OF HEARING:

#### Modification (if any):

**Committee Reason:** This proposal was disapproved because the vague language would not be uniformly enforceable. In addition, rotation of the hand held shower is a convenience issue, not an accessibility issue.

**607.6b-REED.doc**



<b>Report for 06-55– 2021</b>		
<i>Committee decision: D</i>	<i>Committee Vote at Meeting: 29-3-1</i>	<i>Committee Vote on Ballot:</i>
<b>REPORT OF HEARING:</b>		
Modification (if any):		
Committee Reason: This proposal was disapproved because the vague language would not be uniformly enforceable. In addition, rotation of the hand held shower is a convenience issue, not an accessibility issue.		
<b>PUBLIC COMMENT- FIRST DRAFT:</b>		
Proponent:		
Desired Action:		
Modification:		
Reason:		
<i>Committee decision: AS/AM/D</i>	<i>Committee Vote at Meeting:</i>	<i>Committee Vote on Ballot:</i>
<b>REPORT OF HEARING – FIRST DRAFT</b>		
Modification (if any):		
Committee Reason:		
<b>PUBLIC COMMENT- SECOND DRAFT:</b>		
Proponent:		
Desired Action:		
Modification:		
Reason:		
<i>Committee decision: AS/AM/D</i>	<i>Committee Vote at Meeting:</i>	<i>Committee Vote on Ballot:</i>
<b>FINAL ACTION:</b>		
Modification (if any):		
Committee Reason:		

## 06-56 – 2021

### 607.8, 608.8

**Proponent:** Kimberly Paarlberg, International Code Council

**Delete without substitution:**

#### SECTION 607 BATHTUBS

~~**607.8 Water temperature.** Bathtubs shall deliver water that is 120°F (49°C) maximum.~~

#### SECTION 608 SHOWER COMPARTMENTS

~~**608.8 Water temperature.** Showers shall deliver water that is 120°F (49°C) maximum.~~

---

**REASON:** The intent of this proposal is to remove the water temperature limit for bathtubs and showers. This is a plumbing code issue, not an accessibility issue – and the plumbing code does have similar limits. The person using the tub or shower will adjust the temperature before the enter the water the same as anyone else. The handheld shower heads have a shut off as a backup if they cannot reach the water controls from the seat. Some people prefer hotter showers.

Committee Action: As submitted 21-9-3

**REPORT OF HEARING:**

**Modification (if any):**

**Committee Reason:** Water temperature at bathtubs and showers are regulated by the plumbing codes. This is not an accessibility issue.

**608.8-PAARLBERG.doc**

<b>Report for 06-56- 2021</b>		
<b>Committee decision: AS</b>	<b>Committee Vote at Meeting: 21-9-3</b>	<b>Committee Vote on Ballot:</b>
<b>REPORT OF HEARING:</b>		
Modification (if any):		
Committee Reason: Water temperature at bathtubs and showers are regulated by the plumbing codes. This is not an accessibility issue.		
<b>PUBLIC COMMENT- FIRST DRAFT:</b>		
Proponent:		
Desired Action:		
Modification:		
Reason:		
<b>Committee decision: AS/AM/D</b>	<b>Committee Vote at Meeting:</b>	<b>Committee Vote on Ballot:</b>
<b>REPORT OF HEARING – FIRST DRAFT</b>		
Modification (if any):		
Committee Reason:		
<b>PUBLIC COMMENT- SECOND DRAFT:</b>		
Proponent:		
Desired Action:		
Modification:		
Reason:		
<b>Committee decision: AS/AM/D</b>	<b>Committee Vote at Meeting:</b>	<b>Committee Vote on Ballot:</b>
<b>FINAL ACTION:</b>		
Modification (if any):		
Committee Reason:		

# 06-57 – 2021

## 607.4(New)

**Proponent:** Marsha Mazz, United Spinal Association

**Add new text as follows:**

### SECTION 607 BATHTUBS

**607.4 Bathtub rim.** The height of the bathtub rim shall not exceed the height of the bathtub seat required by Section 607.3.

**REASON:** The intent of this proposal is to ensure that people transferring to a bathtub set will not have to also transfer over the rim of the bathtub and down into the seat and back up over the rim. This will better protect users from injuries due to complex transfers.

Committee Action: As submitted 19-10-2

#### REPORT OF HEARING:

##### Modification (if any):

**Committee Reason:** This proposal was approved because the rim of the tub should not be higher than the seat height in order to allow for smooth transfer to the seat. The committee discussed tubs where the rim height varies. This measurement should be taken at the seat location.

607.9-MAZZ.doc

Report for 06-57– 2021		
Committee decision: AS	Committee Vote at Meeting: 19-10-2	Committee Vote on Ballot:
<b>REPORT OF HEARING:</b>		
Modification (if any):		
Committee Reason: This proposal was approved because the rim of the tub should not be higher than the seat height in order to allow for smooth transfer to the seat. The committee discussed tubs where the rim height varies. This measurement should be taken at the seat location.		
<b>PUBLIC COMMENT- FIRST DRAFT:</b>		
Proponent:		
Desired Action:		
Modification:		
Reason:		
Committee decision: AS/AM/D	Committee Vote at Meeting:	Committee Vote on Ballot:
<b>REPORT OF HEARING – FIRST DRAFT</b>		
Modification (if any):		
Committee Reason:		
<b>PUBLIC COMMENT- SECOND DRAFT:</b>		
Proponent:		
Desired Action:		
Modification:		
Reason:		
Committee decision: AS/AM/D	Committee Vote at Meeting:	Committee Vote on Ballot:
<b>FINAL ACTION:</b>		

<b>Report for 06-57– 2021</b>
Modification (if any):
Committee Reason:

## 06-58 – 2021

### 608.2.1.1, Figure 608.2.1.1

**Proponent:** Doug Anderson, representing A117.1 Accessible Bathing Task Group

**Revise as follows:**

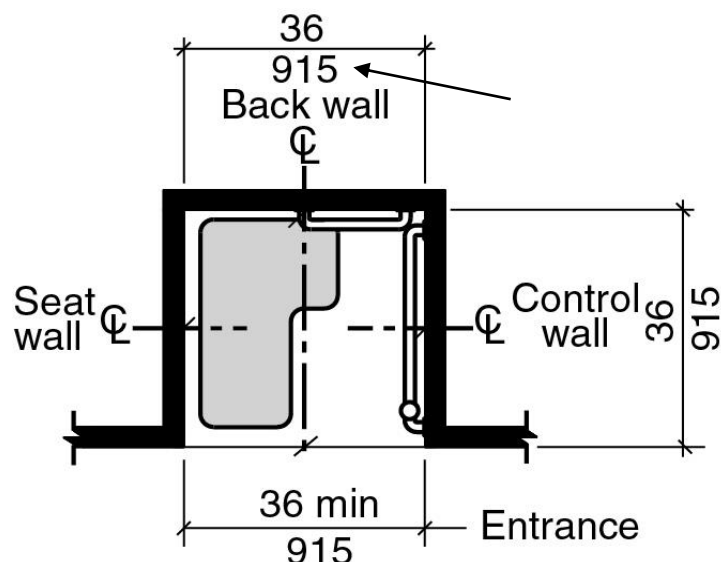
#### SECTION 608 SHOWER COMPARTMENTS

**608.1 General.** Shower compartments shall comply with Section 608.

**608.2 Size, clearance and seat.** Shower compartments shall have sizes, clearances and seats complying with Section 608.2.

**608.2.1 Transfer-type shower compartments.** Transfer-type shower compartments shall comply with Section 608.2.1.

**608.2.1.1 Size.** Transfer-type shower compartments shall have a clear inside dimension of ~~36~~ 35 to 37 inches (915 889-940 mm) in width measured at the center point of opposing sides and ~~36~~ 35 to 37 inches (915 889-940 mm) in depth measured from the center point of opposing sides the rear wall to the to the outside of the threshold. An entry 36 inches (915 mm) minimum in width shall be provided.



**Note:** inside finished dimensions measured at the center points of opposing sides

**FIGURE 608.2.1.1**  
**TRANSFER-TYPE SHOWER COMPARTMENT SIZE**

*Note: Modify figure to include new dimension range.*

---

**REASON:** This proposal is seeking to build in construction tolerance to the transfer shower inside dimensions.

---

**06-58 – 2021 modification**

**608.2.1.1, Figure 608.2.1.1**

**Proponent:** Scott Brady, representing Fiat and Stern-Williams

**Further modify as follows:**

**SECTION 608**  
**SHOWER COMPARTMENTS**

**608.1 General.** Shower compartments shall comply with Section 608.

**608.2 Size, clearance and seat.** Shower compartments shall have sizes, clearances and seats complying with Section 608.2.

**608.2.1 Transfer-type shower compartments.** Transfer-type shower compartments shall comply with Section 608.2.1.

**608.2.1.1 Size.** Transfer-type shower compartments shall have a clear inside dimension of 35 to 37 inches (889-940 mm) in width measured at the center point of opposing sides and 35 to 37 inches (889-940 mm) in depth measured from the center point of the rear wall to the outside of the threshold. Shower compartment dimensions shall be measured at a height from 20 inches (508) minimum to 72 inches (1828 mm) maximum above the shower floor. An entry 36 inches (915 mm) minimum in width shall be provided.

Reason: I like the proposed modification to allow for 35-37 inches on the inside wall dimensions. I would like to add that this dimension apply to a certain height range – the working area inside the shower. I’m suggesting this range be from the top of the seat to a height of 6 feet.

Both Fiat and Stern-Williams make shower floors. In typical construction, tile walls sit on top of a ledge on the floor base. We make the floor base 36x36 to meet the standard, but as you move up from the floor, the walls of the base draft outward with radiused corners, then there’s the ledge the wall sits on, so the distance between, centers of the walls can be 40” x 40”. The keep the walls at 36”x36”, we need to make the insides of the floors a little smaller. The same logic applies above the shower. Once you get above a certain height (I’m guessing 6’), the 36” x 36”

working area doesn't matter. The shower may be sitting in an area that expands out another few inches above it.

**TERRAZZO WHEELCHAIR  
SHOWER RECEPTOR**

**TERRAZZO WHEELCHAIR  
SHOWER RECEPTOR**

- No threshold terrazzo wheelchair receptor with stainless steel strainer plate.
- One piece floor fabricated from precast terrazzo, made of black and white marble chips cast in white Portland cement.
- Min compressive strength of 3,000 p.s.i. after seven days of curing.
- Recessed for floor installation.
- Factory grounded and polished to remove air holes and/or excess pits grouted.
- Min shoulder of 4" high inside, 6" high outside, with a min of 1/2" wide.
- Integral tiling flange made of galvanized bonderized steel with min of 1" above shoulder.
- Stainless steel and cast integral drain provide a min caulked lead connection of 1" deep, to a 2" pipe. Quick drain connection using a QDC-4 connector can also be used.
- Complies to 2010 ADA guideline.



**Nominal Dimensions:**

- ADATN3636** 41.23" x 38.62" (1047 x 981mm)
- ADATN6030** 65.23" x 32.62" (1657 x 829mm)
- ADATN6036** 65.23" x 38.62" (1657 x 981mm)

**NOTES:**

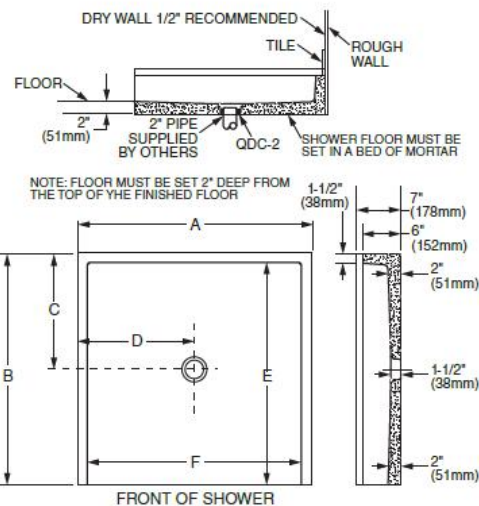
Establish 1/4" clearance between shower floor and wall. It is required that the entire area between the receptor and the building floor have a 1/2" layer of mortar in order that shower floors be level.

It is recommended that a floor drain be installed at or near the entrance of the shower.

All models comply with Americans With Disabilities Act and A117.1 handicapped standards.

**IMPORTANT:** Rough-in dimensions may vary 1/2" and are subject to change or cancellation without prior notice.

**MEETS THE AMERICANS WITH DISABILITIES ACT GUIDELINES AND ANSI A117.1 ACCESSIBLE AND USABLE BUILDINGS AND FACILITIES - CHECK LOCAL CODES.**



**OFFERED IN 081 FINISH  
ONLY - WHITE CEMENT W/  
BLACK & WHITE CHIPS**

	OUTSIDE DIMENSIONS				MINIMUM INSIDE DIMENSIONS	
	A	B	C	D	E	F
ADATN-3636	41.23" (1047mm)	38.62" (981mm)	18.31" (465mm)	20.62" (524mm)	36" (914mm)	36" (914mm)
ADATN-6030	65.23" (1657mm)	32.62" (829mm)	15.75" (400mm)	32.62" (829mm)	30" (762mm)	60" (1542mm)
ADATN-6036	65.23" (1657mm)	38.62" (981mm)	15.75" (400mm)	32.62" (829mm)	36" (914mm)	60" (1542mm)

Arch. to confirm if finish is acceptable.

Customer Service Canada  
1-800-387-0369  
www.fiat.ca

**FIAT**  
QUALITY FOR LIFE  
Customer Service United States  
1-800-442-1902  
www.fiatproducts.com



Committee Action: Modification from Brady – failed 7-20-4; As modified 26-4-2

**REPORT OF HEARING:**

**Modification (if any):**  
**Further modify as follows:**

**608.2.1.1 Size.** Transfer-type shower compartments shall have a clear inside dimension of 35 to 37 inches (889-940 mm) in width measured at the center point of opposing sides and 35 to 37 inches (889-940 mm) in depth measured from the center point of the ~~rear~~ back wall to the to the centerline ~~outside~~ of the threshold. An entry 36 inches (915 mm) minimum in width shall be provided.

**Committee Reason:** The modification from ‘rear’ to ‘back’ is to match the terminology in the figure. The modification from ‘outside’ to ‘centerline’ was an attempt to clarify that the size is within the shower, and the width and the location of a threshold are not addressed in the standard or the plumbing codes. There was additional discussion on if the depth of the shower should be the ‘entrance’ since the threshold could be from fully inside to fully outside of the shower itself. There was concern about at what height the shower size should be measured – at the floor (where there can be a curve or side curb) or at the elevations where the size was the concern – knee height for seating and shoulder height for reach to controls and grab bars.

**608.2.2.1-ANDERSON.doc**

<b>Report for 06-58– 2021</b>		
<i>Committee decision: AM</i>	<i>Committee Vote at Meeting: 26-4-2</i>	<i>Committee Vote on Ballot:</i>
<b>REPORT OF HEARING:</b>		
Modification (if any):		
<b>Further modify as follows:</b>		
<p><b>608.2.1.1 Size.</b> Transfer-type shower compartments shall have a clear inside dimension of 35 to 37 inches (889-940 mm) in width measured at the center point of opposing sides and 35 to 37 inches (889-940 mm) in depth measured from the center point of the <del>rear</del> <u>back</u> wall to the to the <u>centerline</u> <del>outside</del> of the threshold. An entry 36 inches (915 mm) minimum in width shall be provided.</p>		
<p>Committee Reason: The modification from ‘rear’ to ‘back’ is to match the terminology in the figure. The modification from ‘outside’ to ‘centerline’ was an attempt to clarify that the size is within the shower, and the width and the location of a threshold are not addressed in the standard or the plumbing codes. There was additional discussion on if the depth of the shower should be the ‘entrance’ since the threshold could be from fully inside to fully outside of the shower itself. There was concern about at what height the shower size should be measured – at the floor (where there can be a curve or side curb) or at the elevations where the size was the concern – knee height for seating and shoulder height for reach to controls and grab bars.</p>		
<b>PUBLIC COMMENT- FIRST DRAFT:</b>		
Proponent:		
Desired Action:		
Modification:		
Reason:		
<i>Committee decision: AS/AM/D</i>	<i>Committee Vote at Meeting:</i>	<i>Committee Vote on Ballot:</i>
<b>REPORT OF HEARING – FIRST DRAFT</b>		
Modification (if any):		
Committee Reason:		
<b>PUBLIC COMMENT- SECOND DRAFT:</b>		
Proponent:		
Desired Action:		
Modification:		
Reason:		
<i>Committee decision: AS/AM/D</i>	<i>Committee Vote at Meeting:</i>	<i>Committee Vote on Ballot:</i>
<b>FINAL ACTION:</b>		
Modification (if any):		
Committee Reason:		

## 06-59 – 2021

**608.2.1.2, 608.2.1.2.1, 608.2.1.3(New), 608.4.1, Figures 608.2.1.2(A), 608.2.1.2(B), 608.2.1.2(C), 608.2.1.3(New), 608.4.1**

**Proponent:** Thomas Hirsch, FAIA, Hirsch Group Architecture, representing self; M. Bradley Gaskins, AIA; Gina Hillberry for United Cerebral Palsy; Joe Jurkiewicz, AIA; Marsha Mazz for United Spinal Association; Edward Steinfeld, Arch.D, AIA; and Steven R. Winkel, FAIA, PE, CASp

**Revise as follows:**

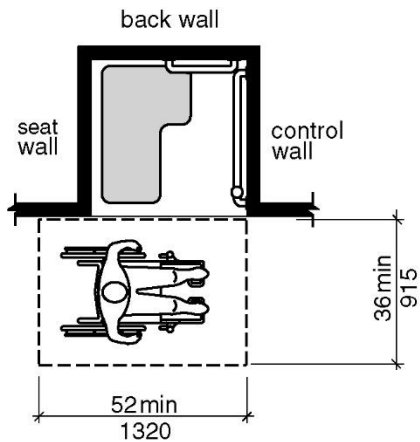
### SECTION 608 SHOWER COMPARTMENTS

#### **608.2.1.2 Transfer Clearance.**

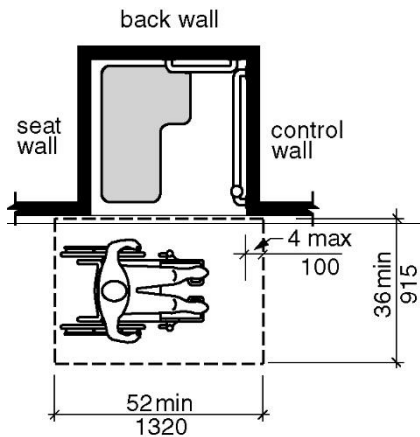
**608.2.1.2.1 New buildings and facilities.** In new buildings and facilities, a clearance of 52 inches (1320 mm) minimum in length and 36 inches (915 mm) minimum in depth shall be provided adjacent to the open face of the compartment. The length of the ~~clear floor space~~ transfer clearance shall be measured perpendicular from either the control wall or from 4 inches (100 mm) behind the control wall.

**608.2.1.2.2 Existing buildings and facilities.** In existing buildings and facilities, a clearance of 48 inches (1220 mm) minimum in length measured perpendicular from the control wall, and 36 inches (915 mm) minimum in depth shall be provided adjacent to the open face of the compartment.

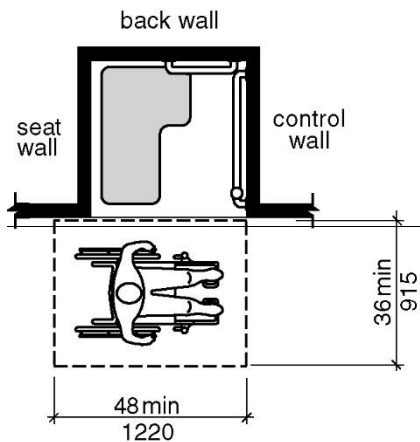
*Note: The committee will need to decide if Figures 608.2.1.2(A), 608.2.1.2(B) and 608.2.1.2(C) should be revised to show the control clearance with the transfer clearance or if the control clearance should be in a separate Figure 608.2.1.3. The figure submitted indicates the clearance moving forward, not an addition 4 inch toe clearance as the text indicates.*



**FIGURE 608.2.1.2(A)**  
**TRANSFER-TYPE SHOWER COMPARTMENT TRANSFER CLEARANCES**  
**NEW BUILDINGS –OPTION 1**



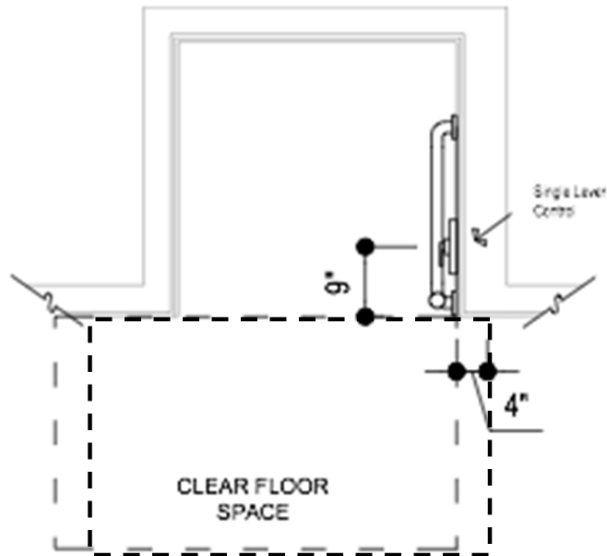
**FIGURE 608.2.1.2(B)**  
**TRANSFER-TYPE SHOWER COMPARTMENT TRANSFER CLEARANCES**  
**NEW BUILDINGS - OPTION 2**



**FIGURE 608.2.1.2(C)**  
**TRANSFER-TYPE SHOWER COMPARTMENT TRANSFER CLEARANCES**

## EXISTING BUILDINGS

**608.2.1.3 Control Clearance.** The clear floor space for toe clearance at the controls shall extend 4 inches (100 mm) minimum beyond the control end wall.



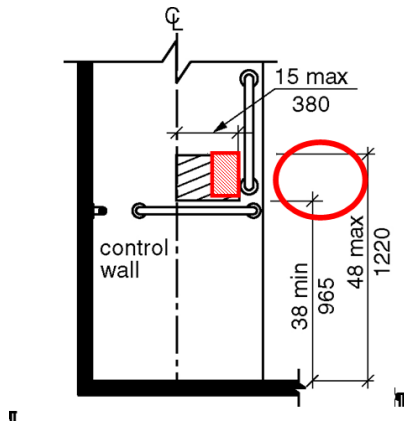
**FIGURE 608.2.1.3**  
**TRANSFER-TYPE SHOWER COMPARTMENT**  
**CLEARANCES FOR SHOWER CONTROLS**

**608.4 Controls and hand showers.** Controls and hand showers shall comply with Sections 608.4 and 309.4.

**608.4.1 Transfer-type showers.** In transfer-type showers, the controls and hand shower shall be located:

1. On the control wall opposite the seat.
2. At a height of 38 inches (965 mm) minimum and 48 inches (1220 mm) maximum above the shower floor, and
3. 15 inches (380 mm) maximum, from the centerline of the control wall toward the shower opening. The centerline of controls measured from the approach side of the shower shall be located 5 inches (127 mm) minimum and 9 inches (229 mm) maximum from the clear floor space.

*Note: The area for the controls in Figure 608.4.1 would be revised to the smaller area indicated in the revised text. Figure 608.3.1(B) indicates the vertical grab bar is 4 inches maximum to the center line of the bar. Section 609.2.1 indicates the diameter of the grab bar is 1-1/4" to 2". Since the control itself is past the control center line on both sides, the committee is requested to address the question of a possible overlap of the vertical grab bar with the controls.*



**FIGURE 608.4.1  
TRANSFER-TYPE SHOWER CONTROLS AND  
HAND SHOWER LOCATION**

*Note: The references from Accessible and Type A units are shown so that the committee is clear on how this proposal will affect unit requirements.*

## **SECTION 1102 ACCESSIBLE UNITS**

**1102.11.2 Toilet and bathing facility.** At least one toilet and bathing facility shall comply with Section 603. At least one lavatory, one water closet and either a bathtub or shower within the unit shall comply with Sections 604 through 610. These toilet and bathing fixtures shall be in a single toilet/bathing area, such that travel between fixtures does not require travel through other parts of the unit.

## **SECTION 1103 TYPE A UNITS**

**1103.11.2.5 Bathing fixtures.** The bathing fixture shall be a bathtub complying with Section 1103.11.2.5.1 or a shower compartment complying with Section 1103.11.2.5.2.

**1103.11.2.5.2 Shower.** Showers shall comply with Section 608.

**Exception:** At standard roll-in shower compartments complying with Section 608.2.2, lavatories, countertops and cabinetry shall be permitted at one end of the clearance, provided the following criteria are met:

1. The countertop and cabinetry can be removed;
2. The floor finish extends under the countertop and cabinetry; and
3. The walls behind and surrounding the countertop and cabinetry are finished.

**REASON:** Based on anthropometry, the provision of toe space past the control end of the fixture accomplishes realistic reach of the control for 90% of persons measured

Notes: Table till end of Chapter 6

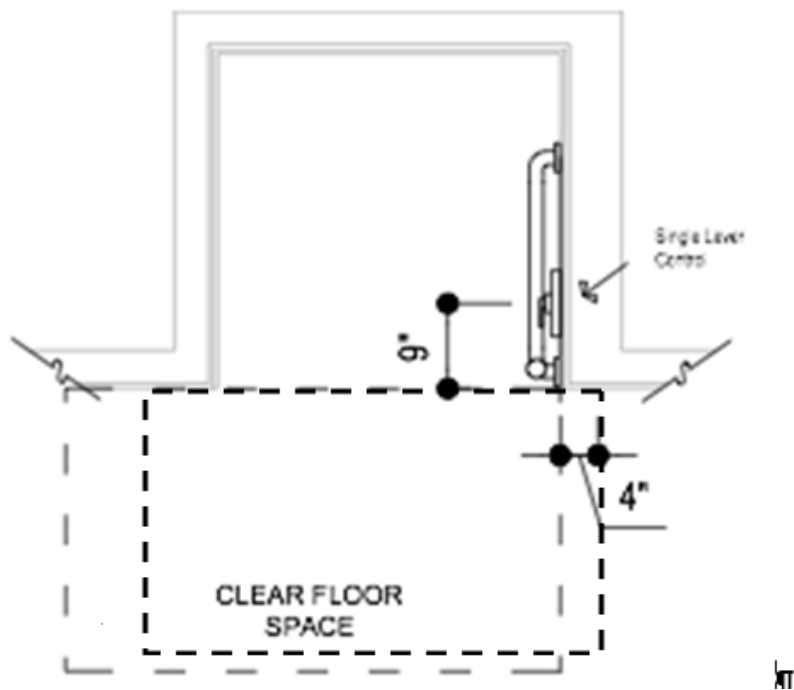
## 06-59 – 2021

608.2.1.2, 608.2.1.2.1, 608.2.1.3(New), 608.4.1, Figures 608.2.1.2(A), 608.2.1.2(B), 608.2.1.2(C), 608.2.1.3(New), 608.4.1

**Proponent:** Thomas Hirsch, FAIA, Hirsch Group Architecture, representing self; M. Bradley Gaskins, AIA; Gina Hillberry for United Cerebral Palsy; Joe Jurkiewicz, AIA; Marsha Mazz for United Spinal Association; Edward Steinfeld, Arch.D, AIA; and Steven R. Winkel, FAIA, PE, CASp

**Further revise as follows:**

**608.2.1.3 Control Clearance.** The clear floor space for toe clearance complying with Section 306.2 at the controls shall extend 4-6 inches (~~100~~ 152 mm) minimum beyond the control end wall.



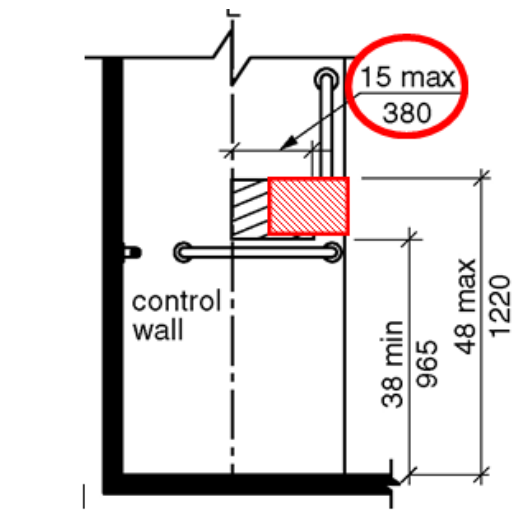
*Note: Figure needs to show 6" instead of 4" offset*

**FIGURE 608.2.1.3  
TRANSFER-TYPE SHOWER COMPARTMENT  
CLEARANCES FOR SHOWER CONTROLS**

**608.4.1 Transfer-type showers.** In transfer-type showers, the controls and hand shower shall be located:

1. On the control wall opposite the seat.
2. At a height of 38 inches (965 mm) minimum and 48 inches (1220 mm) maximum above the shower floor, and
3. The centerline of controls measured from the approach side of the shower shall be located ~~5 inches (127 mm) minimum and~~ 9 inches (229 mm) maximum from the clear floor space.

*Note: The area for the controls in Figure 608.4.1 would be revised to the smaller area indicated in the revised text. Figure 608.3.1(B) indicates the vertical grab bar is 4 inches maximum to the center line of the bar. Section 609.2.1 indicates the diameter of the grab bar is 1-1/4" to 2". Since the control itself is past the control center line on both sides, the committee is requested to address the question of a possible overlap of the vertical grab bar with the controls.*



**FIGURE 608.4.1  
TRANSFER-TYPE SHOWER CONTROLS AND  
HAND SHOWER LOCATION**

**Reason:**

1. Conforms “toe space” with prior use of the term in Sec. 306.2
2. Allows for plumbing valves & piping in common use.

**Staff note:** This requirement would apply to Accessible and Type A units.

Committee Action: Disapproval

The proposal was divided for discussion.

Mod to delete change to 608.4.1 (control location) – AM 23-1-1;

Mod new 608.2.1.3 (toe clearance) AM 9-19-21; D 28-1-1;

Mod for 608.2.1.2 and 608.2.1.2.1 (transfer clearance) AM 12-15-3;

Entire proposal D 28-1-2

**REPORT OF HEARING:**

**Modification (if any):**

**Committee Reason:** The proposal was divided for discussion. The committee voted to delete the change to Section 608.4.1 for control location for consistent action with 06-40-21. They felt that the current language in Section 608.4.1 for control location provided better direction since it included all of the controls (temperature, on/off, diverters) instead of just to the center of a valve. The proposed language assumed one center control, was too restrictive, and did not address the handle locations, spread mount controls or the diverter location. The committee disapproved the modification to add toe clearance because, unlike a tub, the user could move their front wheels into the shower stall if they needed better access to controls. The committee disapproved the change to ‘transfer clearance’ because it is adding another term to the requirements, and was not proposed universally for other transfer spaces. The committee did ask for the editorial or terminology task group to look at consistent use of ‘clearance’ and ‘clear floor space’.

**Figure 608.2.1-HIRSCH.doc**

<b>Report for 06-59- 2021</b>		
<i>Committee decision: D</i>	<i>Committee Vote at Meeting: 28-1-2</i>	<i>Committee Vote on Ballot:</i>
<b>REPORT OF HEARING:</b>		
Modification (if any):		
Committee Reason: The proposal was divided for discussion. The committee voted to delete the change to Section 608.4.1 for control location for consistent action with 06-40-21. They felt that the current language in Section 608.4.1 for control location provided better direction since it included all of the controls (temperature, on/off, diverters) instead of just to the center of a valve. The proposed language assumed one center control, was too restrictive, and did not address the handle locations, spread mount controls or the diverter location. The committee disapproved the modification to add toe clearance because, unlike a tub, the user could move their front wheels into the shower stall if they needed better access to controls. The committee disapproved the change to ‘transfer clearance’ because it is adding another term to the requirements, and was not proposed universally for other transfer spaces. The committee did ask for the editorial or terminology task group to look at consistent use of ‘clearance’ and ‘clear floor space’.		
<b>PUBLIC COMMENT- FIRST DRAFT:</b>		
Proponent:		
Desired Action:		
Modification:		
Reason:		
<i>Committee decision: AS/AM/D</i>	<i>Committee Vote at Meeting:</i>	<i>Committee Vote on Ballot:</i>
<b>REPORT OF HEARING – FIRST DRAFT</b>		
Modification (if any):		
Committee Reason:		
<b>PUBLIC COMMENT- SECOND DRAFT:</b>		
Proponent:		
Desired Action:		
Modification:		
Reason:		
<i>Committee decision: AS/AM/D</i>	<i>Committee Vote at Meeting:</i>	<i>Committee Vote on Ballot:</i>
<b>FINAL ACTION:</b>		
Modification (if any):		
Committee Reason:		



## 06-60 – 2021

### 608.2.1.2.1

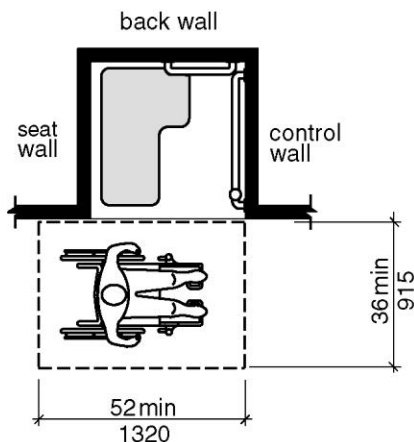
**Proponent:** Gene Boecker, Code Consultants, Inc.

**Revise as follows:**

## SECTION 608 SHOWER COMPARTMENTS

### 608.2.1.2 Clearance.

**608.2.1.2.1 New buildings and facilities.** In new buildings and facilities, a clearance of 52 inches (1320 mm) minimum in length and 36 inches (915 mm) minimum in depth and complying with Section 305.7.1 shall be provided adjacent to the open face of the compartment. The length of the clear floor space shall be measured perpendicular from either the control wall or from 4 inches (100 mm) behind the control wall.



**FIGURE 608.2.1.2(A)**  
**TRANSFER-TYPE SHOWER COMPARTMENT CLEARANCES**  
**NEW BUILDINGS - OPTION 1**

**REASON:** Where the shower is located in an alcove, it is not clear as to whether the wheelchair space should be expanded for an alcove or if the simple dimensions are all that's needed. If a fully accessible shower is to be provided, the necessary maneuvering space should be provided to access it, including the alcove provisions.

## 06-60 – 2021 replacement modification

### 608.2.1.2.1

**Proponent:** Kimberly Paarlberg, International Code Council

**Replace and revise as follows:**

## SECTION 608 SHOWER COMPARTMENTS

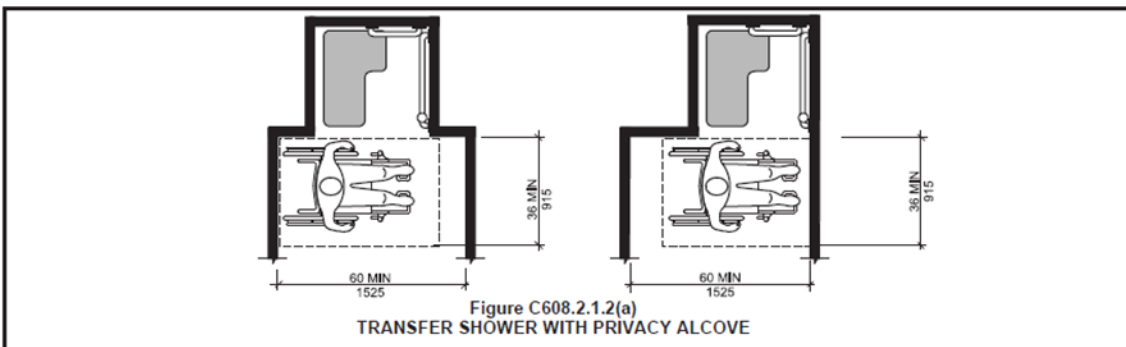
### 608.2.1.2 Clearance.

**608.2.1.2.1 New buildings and facilities.** In new buildings and facilities, a clearance of 52 inches (1320 mm) minimum in length and 36 inches (915 mm) minimum in depth shall be provided adjacent to the open face of the compartment. The length of the clear floor space shall be measured perpendicular from either the control wall or from 4 inches (100 mm) behind the control wall. Where the clearance is an alcove, comply with Section 305.7.

**608.2.1.2.2 Existing buildings and facilities.** In existing buildings and facilities, a clearance of 48 inches (1220 mm) minimum in length measured perpendicular from the control wall, and 36 inches (915 mm) minimum in depth shall be provided adjacent to the open face of the compartment. Where the clearance is an alcove, comply with Section 305.7.

Reason: The current proposal references the parallel approach requirements (Section 305.7.1) regardless of if the transfer space is confined on three sides or not. That needed language is in Section 305.7. In addition, this proposal would only make this applicable for new construction. If a pointer is needed, this should also be added to existing building requirements. Note that dressing rooms in front of showers was addressed in 06-11-2021.

The following pictures are in the ICC A117.1 commentary. Is C608.2.1.2(a) needed to be added to the text to show how this would be applied?



Committee Action: Modification 23-2-2; AM 29-0-3

## REPORT OF HEARING:

### Modification (if any):

Replace and revise as follows:

### SECTION 608 SHOWER COMPARTMENTS

#### 608.2.1.2 Clearance.

**608.2.1.2.1 New buildings and facilities.** In new buildings and facilities, a clearance of 52 inches (1320 mm) minimum in length and 36 inches (915 mm) minimum in depth shall be provided adjacent to the open face of the compartment. The length of the clear floor space shall be measured perpendicular from either the control wall or from 4 inches (100 mm) behind the control wall. Where the clearance is an alcove, the clearance shall comply with Section 305.7.

**608.2.1.2.2 Existing buildings and facilities.** In existing buildings and facilities, a clearance of 48 inches (1220 mm) minimum in length measured perpendicular from the control wall, and 36 inches (915 mm) minimum in depth shall be provided adjacent to the open face of the compartment. Where the clearance is an alcove, the clearance shall comply with Section 305.7.

**Committee Reason:** The committee added “the clearance shall” to the modification as editorial. The modification would provide a pointer for the alcove in front of the shower to both new and existing construction – the original proposal was only for new construction. While this is a pointer, it is necessary because this is a common mistake at transfer showers.

**Staff note:** There is inconsistent language for ‘clearance’ and ‘clear floor space’ in this section. A clear floor space is specified in Section 305.3. An alcove in Section 305.7 provides additional maneuvering space (**not** a clearance or clear floor space). The editorial modification made during the meeting to add “the clearance shall” could be considered a technical change when looking at wheelchair/shower seat alignment for the clear floor space. If the intent of the committee is to allow the alcove to move in either direction as indicated in Figure C608.2.1.2(a) in the reason, staff suggests the following as a clarification.

Further modify as follows:

**608.2.1.2.1 New buildings and facilities.** In new buildings and facilities, a clearance of 52 inches (1320 mm) minimum in length and 36 inches (915 mm) minimum in depth shall be provided adjacent to the open face of the compartment. The length of the ~~clear floor space~~ clearance shall be measured perpendicular from either the control wall or from 4 inches (100 mm) behind the control wall. Where the clearance is located in an alcove, the ~~clearance~~ alcove shall comply with Section 305.7.

**608.2.1.2.2 Existing buildings and facilities.** In existing buildings and facilities, a clearance of 48 inches (1220 mm) minimum in length measured perpendicular from the control wall, and 36 inches (915 mm) minimum in depth shall be provided adjacent to the open face of the compartment. Where the clearance is located in an alcove, the clearance alcove shall comply with Section 305.7.

**608.2.1.2.1-BOECKER.doc**

<b>Report for 06-60- 2021</b>		
<b>Committee decision: AM</b>	<b>Committee Vote at Meeting: 29-0-3</b>	<b>Committee Vote on Ballot:</b>
<b>REPORT OF HEARING:</b>		
Modification (if any):		
Replace and revise as follows:		
<b>SECTION 608 SHOWER COMPARTMENTS</b>		
<b>608.2.1.2 Clearance.</b>		
<p><b>608.2.1.2.1 New buildings and facilities.</b> In new buildings and facilities, a clearance of 52 inches (1320 mm) minimum in length and 36 inches (915 mm) minimum in depth shall be provided adjacent to the open face of the compartment. The length of the clear floor space shall be measured perpendicular from either the control wall or from 4 inches (100 mm) behind the control wall. <u>Where the clearance is an alcove, the clearance shall comply with Section 305.7.</u></p>		
<p><b>608.2.1.2.2 Existing buildings and facilities.</b> In existing buildings and facilities, a clearance of 48 inches (1220 mm) minimum in length measured perpendicular from the control wall, and 36 inches (915 mm) minimum in depth shall be provided adjacent to the open face of the compartment. <u>Where the clearance is an alcove, the clearance shall comply with Section 305.7.</u></p>		
<p>Committee Reason: <b>Committee Reason:</b> The committee added "the clearance shall" to the modification as editorial. The modification would provide a pointer for the alcove in front of the shower to both new and existing construction – the original proposal was only for new construction. While this is a pointer, it is necessary because this is a common mistake at transfer showers.</p>		
<p><b>Staff note:</b> There is inconsistent language for 'clearance' and 'clear floor space' in this section. A clear floor space is specified in Section 305.3. An alcove in Section 305.7 provides additional maneuvering space (<b>not</b> a clearance or clear floor space). The editorial modification made during the meeting to add "the clearance shall" could be considered a technical change when looking at wheelchair/shower seat alignment for the clear floor space. If the intent of the committee is to allow the alcove to move in either direction as indicated in Figure C608.2.1.2(a) in the reason, staff suggests the following as a clarification.</p>		
Further modify as follows:		
<p><b>608.2.1.2.1 New buildings and facilities.</b> In new buildings and facilities, a clearance of 52 inches (1320 mm) minimum in length and 36 inches (915 mm) minimum in depth shall be provided adjacent to the open face of the compartment. The length of the <del>clear floor space</del> <u>clearance</u> shall be measured perpendicular from either the control wall or from 4 inches (100 mm) behind the control wall. Where the clearance is <u>located in</u> an alcove, the <del>clearance alcove</del> shall comply with Section 305.7.</p>		
<p><b>608.2.1.2.2 Existing buildings and facilities.</b> In existing buildings and facilities, a clearance of 48 inches (1220 mm) minimum in length measured perpendicular from the control wall, and 36 inches (915 mm) minimum in depth shall be provided adjacent to the open face of the compartment. Where the clearance is <u>located in</u> an alcove, the <del>clearance alcove</del> shall comply with Section 305.7.</p>		
<b>PUBLIC COMMENT- FIRST DRAFT:</b>		
Proponent:		
Desired Action:		
Modification:		
Reason:		
<b>Committee decision: AS/AM/D</b>	<b>Committee Vote at Meeting:</b>	<b>Committee Vote on Ballot:</b>
<b>REPORT OF HEARING – FIRST DRAFT</b>		
Modification (if any):		
Committee Reason:		
<b>PUBLIC COMMENT- SECOND DRAFT:</b>		
Proponent:		
Desired Action:		
Modification:		
Reason:		
<b>Committee decision: AS/AM/D</b>	<b>Committee Vote at Meeting:</b>	<b>Committee Vote on Ballot:</b>
<b>FINAL ACTION:</b>		
Modification (if any):		
Committee Reason:		

## **06-61 – 2021**

**608.2.2(New), 608.2.2.1(New), 608.2.2.2(New), 608.2.2.3(New), 608.3.2(New), 608.3.2.1(New), 608.3.2.2(New), 608.3.2.3(New), 608.4.2(New), 610.3, 610.3.3(New)**

**Proponent:** Doug Anderson, representing American Hotel and Lodging Association

**Revise as follows:**

### **SECTION 608 SHOWER COMPARTMENTS**

**608.2.2 Alternate transfer shower compartments.** Alternate transfer shower compartments shall comply with Section 608.2.2.

**608.2.2.1 Size.** Alternate transfer shower compartments shall have a clear inside dimension of 58 inches (1473 mm) minimum in width and 30 inches (760 mm) minimum in depth, measured at the center point of opposing sides. An entry 58 inches (1473 mm) minimum in width shall be provided.

**608.2.2.2 Clearance.** A clearance of 60 inches (1525 mm) minimum in length adjacent to the 60-inch (1525 mm) width of the open face of the shower compartment, and 30 inches (760 mm) minimum in depth, shall be provided.

**Exception:** A lavatory complying with Section 606 shall be permitted at the end of the clearance opposite the seat.

**608.2.2.3 Seat.** An adjustable seat complying with Section 610 shall be provided that can be secured at varying distances from the control wall. At least one of the positions will locate the back of the seat between 35 and 37 inches (889 and 940 mm) from the control wall.

**Exception:** A seat is not required to be installed in a shower for a single occupant accessed only through a private office and not for common use or public use, provided reinforcement has been installed in walls and located so as to permit the installation of a shower seat.

**608.3.2 Alternate transfer type shower.** Grab bars in alternate transfer type showers shall comply with Sections 608.3.2.1 through 608.3.2.3.

**608.3.2.1 Back-wall grab bar.** In alternate transfer showers, a grab bar shall be provided on the back wall. The back-wall grab bar shall extend the length of the wall and extend within 6 inches (150 mm) maximum from the adjacent side walls.

**608.3.2.2 Side-wall grab bars.** A grab bar shall be provided on the side-wall opposite the seat. The side wall grab bar shall extend the length of the wall and extend within 6 inches (150 mm) maximum from the adjacent back wall.

**608.3.2.3 Vertical grab bar.** A vertical grab bar 18 inches (455 mm) minimum in length shall be provided on the end wall 3 inches (75 mm) minimum and 6 inches (150 mm) maximum above the horizontal grab bar, and 4 inches (100 mm) maximum inward from the front edge of the shower.

**608.4 Controls and hand showers.** Controls and hand showers shall comply with Sections 608.4 and 309.4.

**608.4.2 Alternate transfer-type showers.** In alternate transfer-type showers, the controls and hand shower shall be located:

1. On the control wall opposite the seat.
2. At a height of 15 inches (381 mm) minimum and 48 inches (1220 mm) maximum above the shower floor, and
3. 15 inches (380 mm) maximum, from the centerline of the control wall toward the shower opening.

**608.6 Thresholds.** Thresholds in roll-in-type shower and compartments shall be 1/2 inch (13 mm) maximum in height in accordance with Section 303. In transfer-type shower compartments, thresholds 1/2 inch (13 mm) maximum in height shall be beveled, rounded, or vertical.

**Exception:** In existing facilities, in transfer-type shower compartments where provision of a threshold 1/2 inch (13 mm) in height would disturb the structural reinforcement of the floor slab, a threshold 2 inches (51 mm) maximum in height shall be permitted.

## SECTION 610 SEATS

**610.3 Shower compartment seats.** The height of shower compartment seats shall be 17 inches (430 mm) minimum and 19 inches (485 mm) maximum above the bathroom floor, measured to the top of the seat. In transfer-type and alternate roll-in-type showers, the seat shall extend along the seat wall to a point within 3 inches (75 mm) of the compartment entry. In standard roll-in-type showers, the seat shall extend from the control wall to a point within 3 inches (75 mm) of the compartment entry. In alternate transfer type showers, the seat shall extend from the back wall to a point within 3 inches (75 mm) of the compartment entry. Seats shall comply with Section 610.3.1 or 610.3.2. In alternate transfer type showers the seat shall also have a seat back comply with Section 610.3.3.

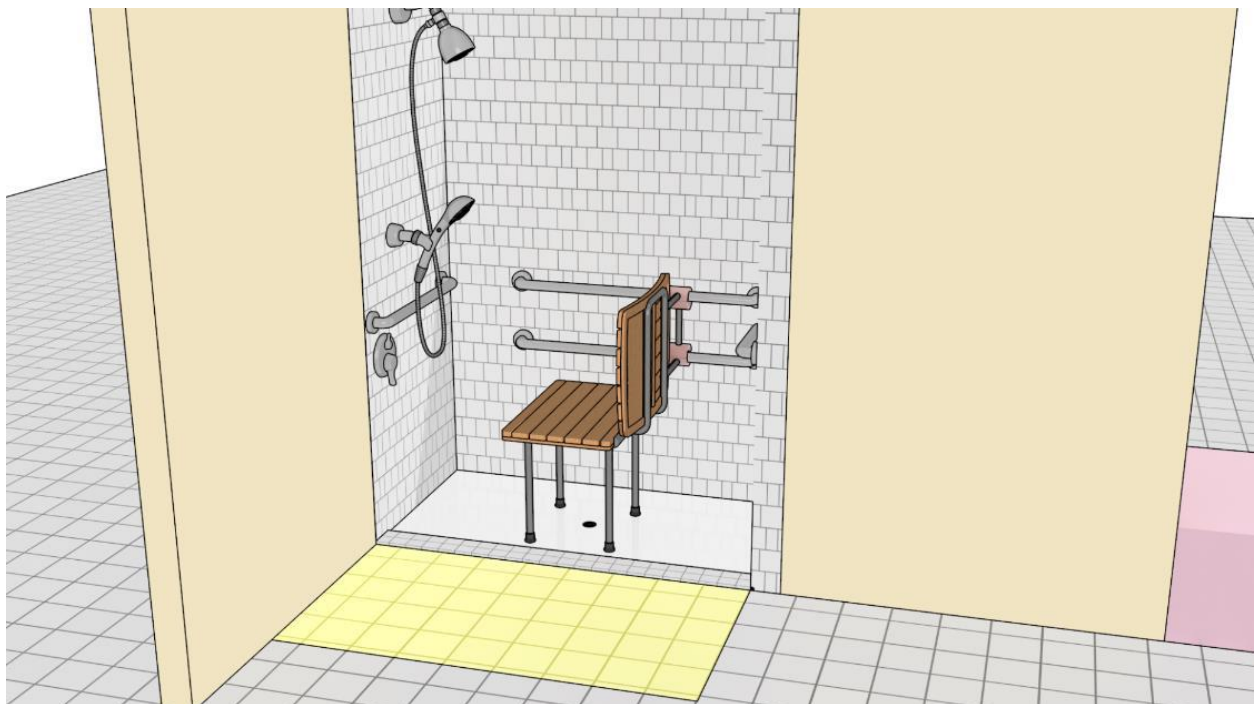
**610.3.1 Rectangular seats.** The rear edge of a rectangular seat shall be 2 1/2 inches (64 mm) maximum and the front edge 15 inches (380 mm) minimum and 16 inches (405 mm) maximum from the seat wall. The side edge of the seat shall be 1 1/2 inches (38 mm) maximum from the back wall of a transfer-type shower and 1 1/2 inches (38 mm) maximum from the control wall of a roll-in-type shower.

**610.3.2 L-shaped seats.** The rear edge of an L-shaped seat shall be 2 1/2 inches (64 mm) maximum and the front edge 15 inches (380 mm) minimum and 16 inches (405 mm) maximum from the seat wall. The rear edge of the “L” portion of the seat shall be 1 1/2 inches

(38 mm) maximum from the wall and the front edge shall be 14 inches (355 mm) minimum and 15 inches (380 mm) maximum from the wall. The end of the “L” shall be 22 inches (560 mm) minimum and 23 inches (585 mm) maximum from the main seat wall.

**610.3.3 Seat backs.** In alternate transfer type showers the seat shall be provided with a back support that is the length of the seat and that shall extend from a point 2 inches (51 mm) maximum above the seat surface to a point 18 inches (455 mm) minimum above the seat surface.

**REASON:** An alternate transfer shower could offer another bathing option that would fit in the footprint of a bathtub and provide more flexible options for assisted bathing.



Committee Action: As modified 21-2-1

**REPORT OF HEARING:**

**Modification (if any):** Mod 23-2-1 Section 608.3.2, Mod 21-2-1 to 608.2.2; modification to 608.3.2 editorial; AM 21-2-1

Further revise as follows:

**608.2.2 Alternate transfer shower compartments.** In existing buildings and facilities, Alternate transfer shower compartments shall comply with Section 608.2.2.



**608.2.2.3 Seat.** An **adjustable** seat complying with Section 610 shall be provided that can be secured at varying distances from the control wall. At least one of the positions will locate the back of the seat between 35 and 37 inches (889 and 940 mm) from the control wall.

**Exception:** A seat is not required to be installed in a shower for a single occupant accessed only through a private office and not for common use or public use, provided reinforcement has been installed in walls and located so as to permit the installation of a shower seat.

**608.3.2 Alternate transfer type shower.** Grab bars in alternate transfer type showers shall comply with Section 609 and be provided in accordance with Sections 608.3.2.1 through 608.3.2.3.

**Committee Reason:** The modification to Section 608.2.2 was so that this option is only within existing buildings. The modification to 608.2.2.3 to delete ‘adjustable’ was to clarify that only the distance from the control wall varies, not everything else about the seat. The modification to 608.3.2 was for a specific reference to the grab bar requirements. The proposal was approved as this option for an alternate transfer shower will offer another bathing option that would fit in the footprint of a bathtub and provide more flexible options for assisted bathing.

**608.2.1.4(NEW) ANDERSON**

<b>Report for 06-61– 2021</b>		
<i>Committee decision: AM</i>	<i>Committee Vote at Meeting: 21-2-1</i>	<i>Committee Vote on Ballot:</i>
<b>REPORT OF HEARING:</b>		
Modification (if any):		
Further revise as follows:		
<b>608.2.2 Alternate transfer shower compartments.</b> <u>In existing buildings and facilities,</u> Alternate transfer shower compartments shall comply with Section 608.2.2.		
<b>608.2.2.3 Seat.</b> An <b>adjustable</b> seat complying with Section 610 shall be provided that can be secured at varying distances from the control wall. At least one of the positions will locate the back of the seat between 35 and 37 inches (889 and 940 mm) from the control wall.		
<b>Exception:</b> A seat is not required to be installed in a shower for a single occupant accessed only through a private office and not for common use or public use, provided reinforcement has been installed in walls and located so as to permit the installation of a shower seat.		
<b>608.3.2 Alternate transfer type shower.</b> Grab bars in alternate transfer type showers shall comply <u>with Section 609 and be provided in accordance</u> with Sections 608.3.2.1 through 608.3.2.3.		
Committee Reason: The modification to Section 608.2.2 was so that this option is only within existing buildings. The modification to 608.2.2.3 to delete ‘adjustable’ was to clarify that only the distance from the control wall varies, not everything else about the seat. The modification to 608.3.2 was for a specific reference to the grab bar requirements. The proposal was approved as this option for an alternate transfer shower will offer another bathing option that would fit in the footprint of a bathtub and provide more flexible options for assisted bathing.		
<b>PUBLIC COMMENT- FIRST DRAFT:</b>		
Proponent:		
Desired Action:		
Modification:		
Reason:		
<i>Committee decision: AS/AM/D</i>	<i>Committee Vote at Meeting:</i>	<i>Committee Vote on Ballot:</i>
<b>REPORT OF HEARING – FIRST DRAFT</b>		
Modification (if any):		
Committee Reason:		
<b>PUBLIC COMMENT- SECOND DRAFT:</b>		
Proponent:		
Desired Action:		
Modification:		
Reason:		
<i>Committee decision: AS/AM/D</i>	<i>Committee Vote at Meeting:</i>	<i>Committee Vote on Ballot:</i>
<b>FINAL ACTION:</b>		
Modification (if any):		
Committee Reason:		





## 06-62 – 2021

608.2.2.2, 608.2.2.3, 806.3.2, 608.3.2.1, 608.3.2.4(New), 608.3.2.5(New), 608.3.2.6(New), 608.4.2, 608.4.3(New), Figure 608.2.2.1, 608.2.2.1(B)(New), 608.2.2.2, 608.3.2(A), 608.3.2(B), 608.3.2(C), 608.3.2(D)(New), 608.4.2, 608.4.3(New)

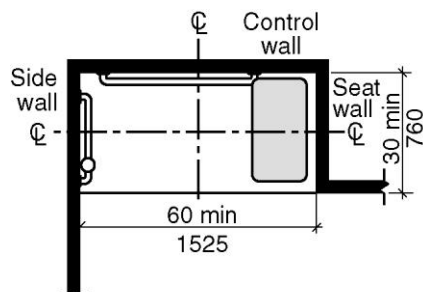
**Proponent:** Kimberly Paarlberg, International Code Council

**Revise as follows:**

### SECTION 608 SHOWER COMPARTMENTS

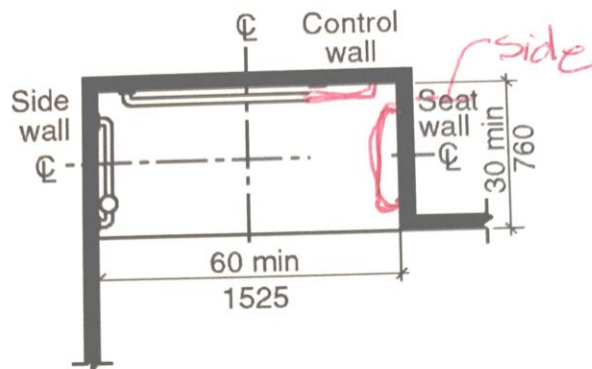
**608.2.2 Standard roll-in-type shower compartments.** Standard roll-in-type shower compartments shall comply with Section 608.2.2.

**608.2.2.1 Size.** Standard roll-in-type shower compartments shall have a clear inside dimension of 60 inches (1525 mm) minimum in width and 30 inches (760 mm) minimum in depth, measured at the center point of opposing sides. An entry 60 inches (1525 mm) minimum in width shall be provided.



Note: inside finished dimensions measured at the center points of opposing sides

**FIGURE 608.2.2.1(A)**  
**STANDARD ROLL-IN-TYPE SHOWER WITH A SEAT**  
**COMPARTMENT SIZE**



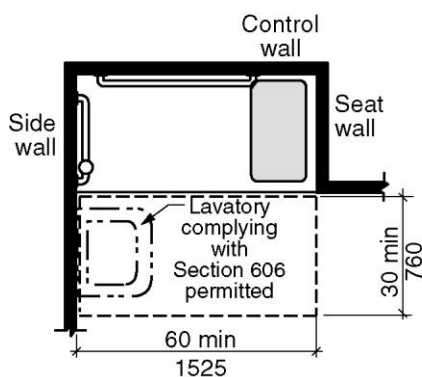
Note: inside finished dimensions measured at the center points of opposing sides

**FIGURE 608.2.2.1(B)**  
**STANDARD ROLL-IN-TYPE SHOWER WITH NO SEAT**  
**COMPARTMENT SIZE**

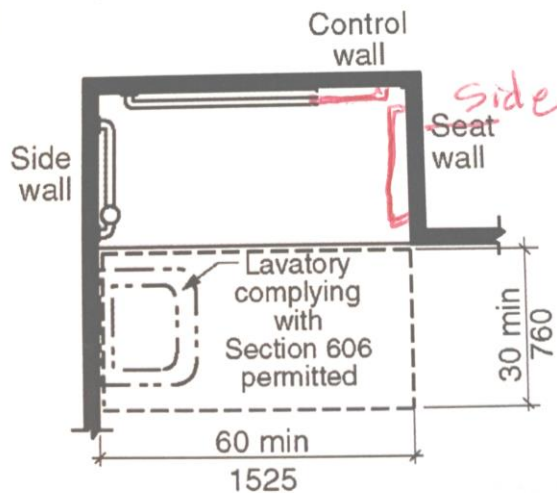
**608.2.2.2 Clearance.** A clearance of 60 inches (1525 mm) minimum in length adjacent to the 60-inch (1525 mm) width of the open face of the shower compartment, and 30 inches (760 mm) minimum in depth, shall be provided.

**Exception Exceptions:**

1. A lavatory complying with Section 606 shall be permitted at the end of the clearance opposite the seat.
2. Where no seat is provided, the lavatory complying with Section 606 shall be permitted at either end of the clearance.



**FIGURE 608.2.2.2(A)**  
**STANDARD ROLL-IN-TYPE SHOWER COMPARTMENT WITH A SEAT**  
**CLEARANCE**



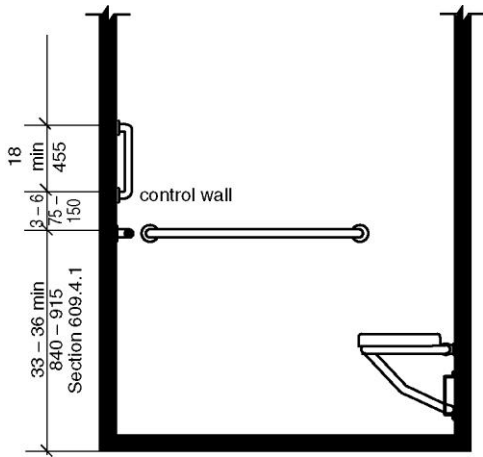
**FIGURE 608.2.2.2(B)**  
**STANDARD ROLL-IN-TYPE SHOWER COMPARTMENT WITH NO SEAT**  
**CLEARANCE**

**608.2.2.3 Seat.** A folding seat complying with Section 610 shall be provided on an end wall.

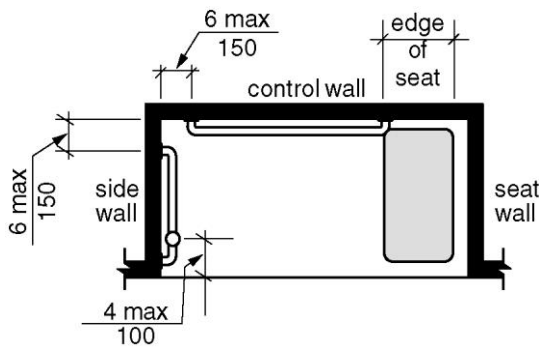
**Exceptions:**

1. A seat is not required to be installed in a shower for a single occupant accessed only through a private office and not for common use or public use, provided reinforcement has been installed in walls and located so as to permit the installation of a shower seat.
2. A fixed seat shall be permitted where the seat does not overlap the minimum clear inside dimension required by Section 608.2.2.1.
3. A seat is not required in bathrooms serving individual dwelling or sleeping units that are not transient lodging facilities.

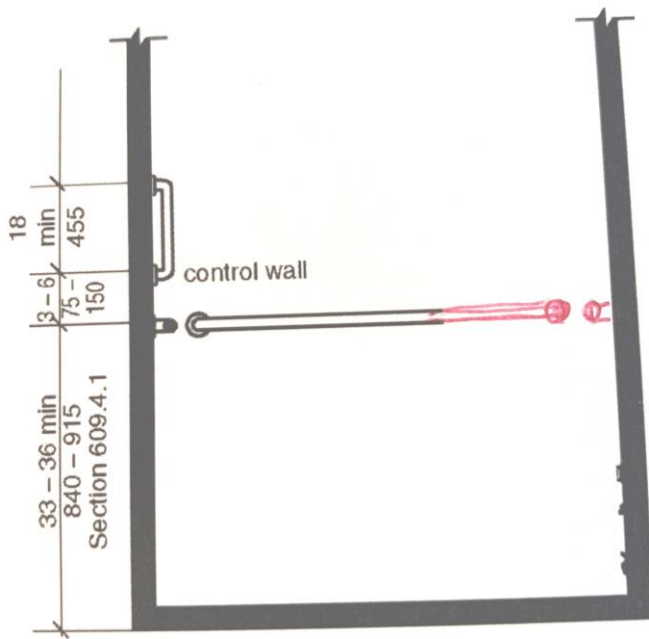
**608.3.2 Standard roll-in-type showers.** Grab bars in standard roll-in showers with a seat shall comply with Sections 608.3.2.1 through 608.3.2.3. Grab bars in standard roll-in showers with no seat shall comply with Section 608.3.2.4 through 608.3.2.5.



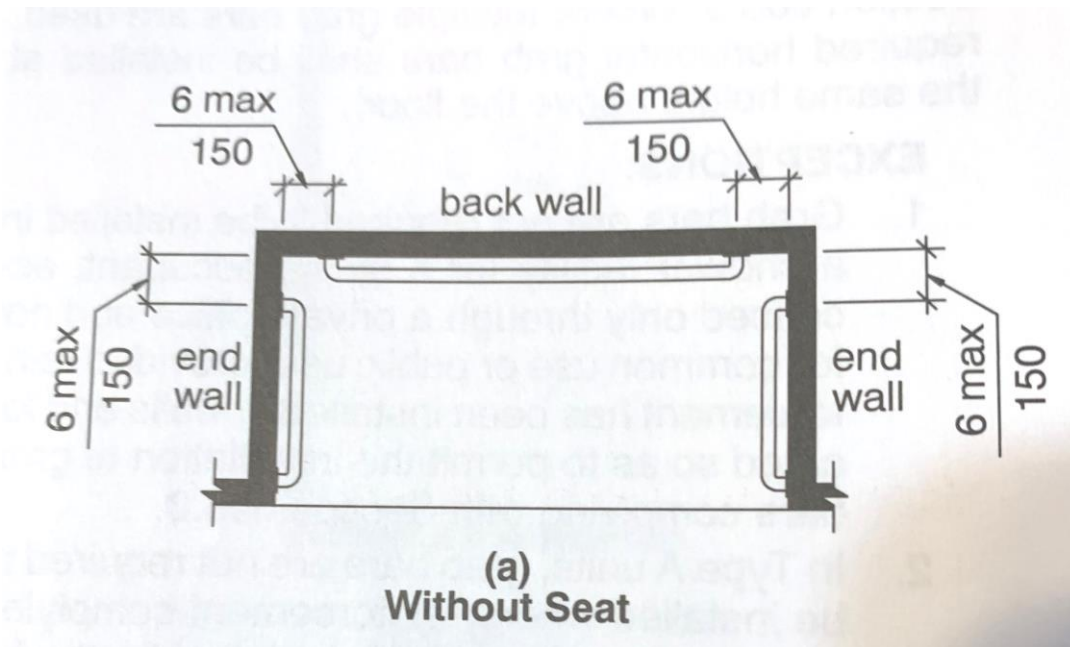
**FIGURE 608.3.2(A)**  
**GRAB BARS IN STANDARD ROLL-IN-TYPE SHOWER WITH A SEAT**  
**ELEVATION**



**FIGURE 608.3.2(B)**  
**GRAB BARS IN STANDARD ROLL-IN-TYPE SHOWER WITH SEAT**  
**PLAN**



**FIGURE 608.3.2(C)**  
**GRAB BARS IN STANDARD ROLL-IN-TYPE SHOWER WITH NO SEAT**  
**ELEVATION**



**FIGURE 608.3.2(D)**  
**GRAB BARS IN STANDARD ROLL-IN-TYPE SHOWER WITH NO SEAT**  
**PLAN**

**608.3.2.1 Back-wall grab bar.** In standard roll-in type showers with a seat, a grab bar shall be provided on the back wall beginning at the edge of the seat. The grab bars shall not be provided above the seat. The back-wall grab bar shall extend the length of the wall and extend within 6 inches (150 mm) maximum from the adjacent side wall opposite the seat.

**Exceptions:**

1. The back wall grab bar shall not be required to exceed 48 inches (1220 mm) in length.
2. The back-wall grab bar is not required to extend within 6 inches (150 mm) of the adjacent side wall opposite the seat if it would require the grab bar length to exceed 48 inches (1220 mm) in length.

**608.3.2.2 Side-wall grab bars.** Where a side wall is provided opposite the seat within 72 inches (1830 mm) of the seat wall, a grab bar shall be provided on the side-wall opposite the seat. The side wall grab bar shall extend the length of the wall and extend within 6 inches (150 mm) maximum from the adjacent back wall.

**Exception:** The side-wall grab bar shall not be required to exceed 30 inches (760 mm) in length.

**608.3.2.3 Vertical grab bar.** Where a side wall is provided opposite the seat within 72 inches (1830 mm) of the seat wall a vertical grab bar shall be provided. A vertical grab bar 18 inches (455 mm) minimum in length shall be provided on the end wall 3 inches (75 mm) minimum and 6 inches (150 mm) maximum above the horizontal grab bar, and 4 inches (100 mm) maximum inward from the front edge of the shower.

**608.3.2.4 Back-wall grab bar.** In standard roll-in type showers with no seat, a grab bar shall be provided on the back wall. The back-wall grab bar shall extend the length of the wall and extend within 6 inches (150 mm) maximum from the adjacent side walls.

**Exceptions:**

1. The back wall grab bar shall not be required to exceed 48 inches (1220 mm) in length.
2. The back-wall grab bar is not required to extend within 6 inches (150 mm) of one of the adjacent side walls if it would require the grab bar length to exceed 48 inches (1220 mm) in length.

**608.3.2.5 Side-wall grab bars.** A grab bar shall be provided on the side-walls. The side wall grab bar shall extend the length of the wall and extend within 6 inches (150 mm) maximum from the adjacent back wall.

**Exceptions:**

1. The side-wall grab bar shall not be required to exceed 30 inches (760 mm) in length.
2. Where the side walls are greater than 72 inches apart the side grab bar is not required on the wall furthest from the horizontal bar.

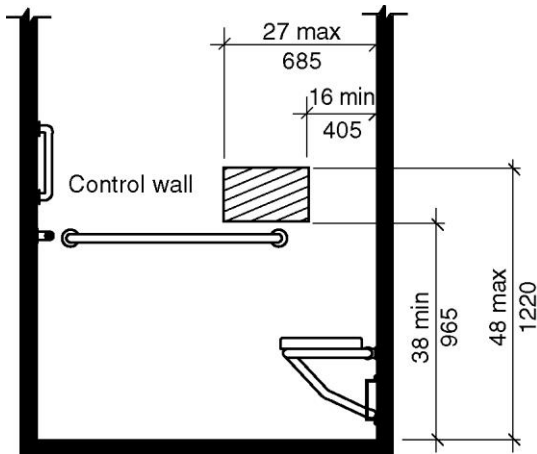
**608.3.2.6 Vertical grab bar.** A vertical grab bar 18 inches (455 mm) minimum in length shall be provided on the end wall 3 inches (75 mm) minimum and 6 inches (150 mm)

maximum above the horizontal grab bar, and 4 inches (100 mm) maximum inward from the front edge of the shower.

**608.4 Controls and hand showers.** Controls and hand showers shall comply with Sections 608.4 and 309.4.

**608.4.2 Standard roll-in showers.** In standard roll-in showers with seat, the controls and hand shower shall not be located above the seat. Controls and hand showers shall be located according to the following:

1. On the back wall,
2. At a height of 38 inches (965 mm) minimum and 48 inches (1220 mm) maximum above the shower floor and
3. 16 inches (405 mm) minimum and 27 inches (685 mm) maximum from the wall behind the seat.

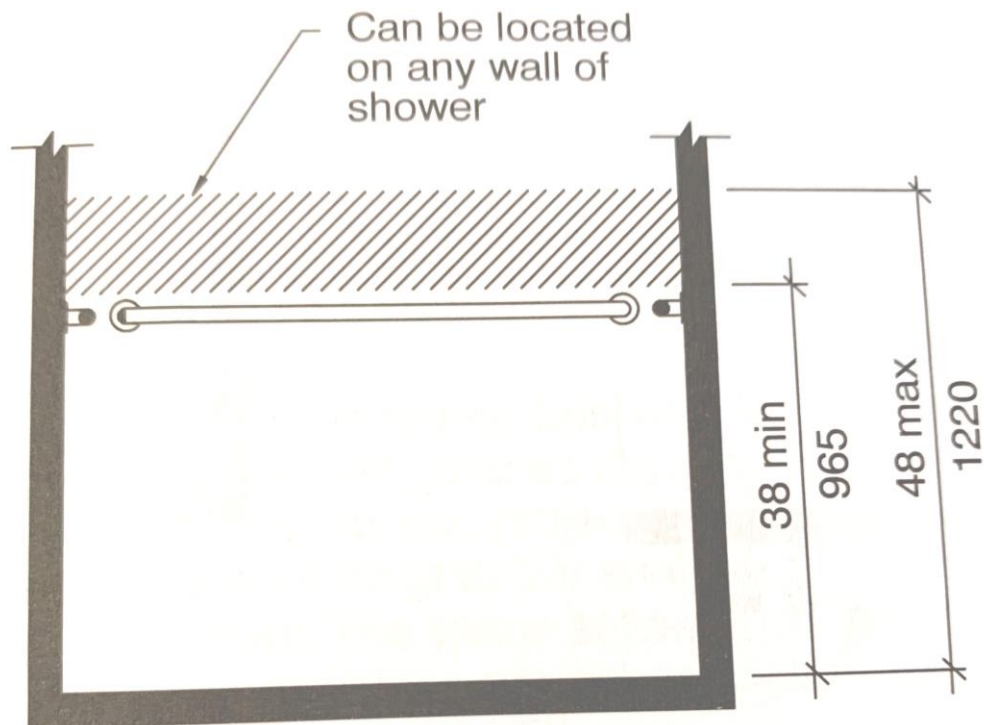


**FIGURE 608.4.2**  
**STANDARD ROLL-IN-TYPE SHOWER WITH SEAT**  
**CONTROLS AND HAND SHOWER LOCATION**

**608.4.3 Standard roll-in showers.** In standard roll-in showers with no seat, the controls and hand showers shall be located according to the following:

1. On the back wall or side walls.
2. At a height of 38 inches (965 mm) minimum and 48 inches (1220 mm) maximum above the shower floor.





**FIGURE 608.4.3**  
**STANDARD ROLL-IN-TYPE SHOWER WITH NO SEAT**  
**CONTROLS AND HAND SHOWER LOCATION**

**REASON:** The purpose of this proposal is to bring back the option of the roll-in shower without seats to some residential or institutional occupancies. This is permitted in the 2010 ADA. Since we made this change there has been questions about allowing for this option where people are likely to have their own seats. While we did have a work group looking at assisted toileting and bathing, the scoping is only for some rooms in assisted living, nursing homes and rehabilitation hospitals. This option should be available in other living situations such as group homes or within Type A units.

## **06-62 – 2021 modification**

**Proponent:** Kimberly Paarlberg, International Code Council

**Further revise as follows:**

**608.3.2.4 Back-wall grab bar.** In standard roll-in type showers with no seat, a grab bar shall be provided on the back wall. The back-wall grab bar shall extend the length of the wall and extend within 6 inches (150 mm) maximum from the adjacent side walls.

**Exceptions:**

1. The back wall grab bar shall not be required to exceed 48 inches (1220 mm) in length-
2. ~~The and one end of the back-wall grab bar is not required to extend~~ is located within 6 inches (150 mm) of one of the adjacent side wall that also has a horizontal grab bar walls if it would require the grab bar length to exceed 48 inches (1220 mm) in length.

**608.3.2.5 Side-wall grab bars.** A grab bar shall be provided on the side-walls. The side wall grab bar shall extend the length of the wall and extend within 6 inches (150 mm) maximum from the adjacent back wall.

**Exceptions:**

1. The side-wall grab bar shall not be required to exceed 30 inches (760 mm) in length and one end of the side-wall grab bar is located within 6 inches of the rear wall.
2. Where the side walls are greater than 72 inches apart, one of the side wall grab bar ~~bars~~ is not required on the wall furthest from the horizontal bar.

---

**Reason:** The allowance for a larger shower has developed in the A117.1 since the three grab bar option was removed from the ICC A117.1, thus the need for the exceptions that were not there before. The intent it to have two grab bars in the same corner. Best practice would have this closest to the fixed shower head or hand held shower, but where that is located will vary so much the requirements should not be measured from that location. The modification is proposed to be revised for consistency with the language in Proposal 06-84-2021 (Section 611.7.4.1) and based on suggestions for improvement for the language.

---

Committee Action: As Modified 29-0-0  
modification to change 'and' to 'where' 23-1-3

**REPORT OF HEARING:**

**Modification (if any):**

**Further modify published modification:**

**608.3.2.4 Back-wall grab bar.** In standard roll-in type showers with no seat, a grab bar shall be provided on the back wall. The back-wall grab bar shall extend the length of the wall and extend within 6 inches (150 mm) maximum from the adjacent side walls.

**Exceptions:**

1. The back wall grab bar shall not be required to exceed 48 inches (1220 mm) in length ~~and~~ where one end of the back-wall grab bar is located within 6 inches (150 mm) of the adjacent side wall that also has a horizontal grab bar.

**608.3.2.5 Side-wall grab bars.** A grab bar shall be provided on the side-walls. The side wall grab bar shall extend the length of the wall and extend within 6 inches (150 mm) maximum from the adjacent back wall.

**Exceptions:**

1. The side-wall grab bar shall not be required to exceed 30 inches (760 mm) in length and where one end of the side-wall grab bar is located within 6 inches of the rear wall.
2. Where the side walls are greater than 72 inches apart, one of the side wall grab bars is not required.

**Committee Reason:** The modifications, both the published modification and the committee modification, is for consistency with the language in Proposal 06-84-2021 (Section 611.7.4.1) and based on suggestions for improvement for the language. The option for showers with three grab bars and no seat should be permitted in occupancies other than transient lodging. This would work well in care facilities, hospitals, group homes and Type A units.

**Staff note:** The following additional modifications would be required to coordinate with 06-80.

**608.3.2.4 Back-wall grab bar.** In standard roll-in type showers with no seat, a grab bar shall be provided on the back wall. The back-wall grab bar shall extend the length of the wall and extend within 6 inches (150 mm) maximum from the adjacent side walls.

**Exception:** The back wall grab bar shall not be required to exceed 48 inches (1220 mm) in length and shall be located with where one end ~~of the back wall grab bar is located~~ within 6 inches (150 mm) of the adjacent side walls that also has a horizontal grab bar.

**608.3.2.5 Side-wall grab bars.** A grab bar shall be provided on the side-walls. The side wall grab bar shall extend the length of the wall beginning 4 inches (100 mm) maximum from the front edge of the shower compartment and extend within 6 inches (150 mm) maximum from the adjacent back wall.

**Exceptions:**

1. The side-wall grab bar shall not be required to exceed 30 inches (760 mm) in length and shall be located with where one end ~~of the side wall grab bar is located~~ within 6 inches of the ~~rear~~ adjacent back wall.
2. Where the side walls are greater than 72 inches apart, one of the side wall grab bars is not required.

608.2.2-PAARLBERG.doc

Report for 06-62- 2021		
Committee decision: AM	Committee Vote at Meeting: 23-1-3	Committee Vote on Ballot:
<b>REPORT OF HEARING:</b> Modification (if any): <b>Further revise as follows:</b>		
<p><b>608.3.2.4 Back-wall grab bar.</b> In standard roll-in type showers with no seat, a grab bar shall be provided on the back wall. The back-wall grab bar shall extend the length of the wall and extend within 6 inches (150 mm) maximum from the adjacent side walls.</p> <p><b>Exceptions:</b></p> <ol style="list-style-type: none"> <li>1. The back wall grab bar shall not be required to exceed 48 inches (1220 mm) in length-</li> <li>2. <del>The where one end of the back-wall grab bar is not required to extend is located</del> within 6 inches (150 mm) of one of the adjacent side wall that also has a horizontal grab bar walls if it would require the grab bar length to exceed 48 inches (1220 mm) in length.</li> </ol>		
<p><b>608.3.2.5 Side-wall grab bars.</b> A grab bar shall be provided on the side-walls. The side wall grab bar shall extend the length of the wall and</p>		

**Report for 06-62– 2021**

extend within 6 inches (150 mm) maximum from the adjacent back wall.

**Exceptions:**

- 3. The side-wall grab bar shall not be required to exceed 30 inches (760 mm) in length where one end of the side-wall grab bar is located within 6 inches of the rear wall.
- 4. Where the side walls are greater than 72 inches apart, one of the side wall grab bars is not required on the wall furthest from the horizontal bar.

Committee Reason: The modifications, both the published modification and the committee modification, was to clarify the requirements for grab bars in a shower that is larger than the typical size. The option for showers with three grab bars and no seat should be permitted in occupancies other than transient lodging. This would work well in care facilities, hospitals, group homes and Type A units.

**Staff note:** The following additional modifications would be required to coordinate with 06-80.

**608.3.2.4 Back-wall grab bar.** In standard roll-in type showers with no seat, a grab bar shall be provided on the back wall. The back-wall grab bar shall extend the length of the wall and extend within 6 inches (150 mm) maximum from the adjacent side walls.

**Exception:** The back wall grab bar shall not be required to exceed 48 inches (1220 mm) in length and shall be located with where one end of the back-wall grab bar is located within 6 inches (150 mm) of the adjacent side walls that also has a horizontal grab bar.

**608.3.2.5 Side-wall grab bars.** A grab bar shall be provided on the side-walls. The side wall grab bar shall extend the length of the wall beginning 4 inches (100 mm) maximum from the front edge of the shower compartment and extend within 6 inches (150 mm) maximum from the adjacent back wall.

**Exceptions:**

- 1. The side-wall grab bar shall not be required to exceed 30 inches (760 mm) in length and shall be located with where one end of the side-wall grab bar is located within 6 inches of the rear adjacent back wall.
- 2. Where the side walls are greater than 72 inches apart, one of the side wall grab bars is not required.

**PUBLIC COMMENT- FIRST DRAFT:**

Proponent:

Desired Action:

Modification:

Reason:

**Committee decision: AS/AM/D**

**Committee Vote at Meeting:**

**Committee Vote on Ballot:**

**REPORT OF HEARING – FIRST DRAFT**

Modification (if any):

Committee Reason:

**PUBLIC COMMENT- SECOND DRAFT:**

Proponent:

Desired Action:

Modification:

Reason:

**Committee decision: AS/AM/D**

**Committee Vote at Meeting:**

**Committee Vote on Ballot:**

**FINAL ACTION:**

Modification (if any):

Committee Reason:

**06-63 – 2021**  
**608.2.2.1**

**Proponent:** Doug Anderson, representing A117.1 Accessible Bathing Task Group

**Revise as follows:**

**SECTION 608**  
**SHOWER COMPARTMENTS**

**608.1 General.** Shower compartments shall comply with Section 608.

**608.2 Size, clearance and seat.** Shower compartments shall have sizes, clearances and seats complying with Section 608.2.

**608.2.1 Transfer-type shower compartments.** Transfer-type shower compartments shall comply with Section 608.2.1.

**608.2.2.1 Size.** Standard roll-in-type shower compartments shall have a clear inside dimension of 60 inches (1525 mm) minimum in width and 30 inches (760 mm) minimum in depth, measured at the center point of opposing sides. An entry 60 inches (1525 mm) minimum in width shall be provided.

**Exception.** In an existing facility where a bathtub is altered to a roll-in shower, the width of the shower shall 58 inches (1473 mm) minimum.

---

**REASON:** This proposal is seeking to acknowledge the standard tub rough opening will not accommodate a 60” clear interior width for a roll-in shower.

Staff Note: 06-64 considered before 06-63.

Committee Action: Disapproved 24-0-2

**REPORT OF HEARING:**

**Modification (if any):**

**Committee Reason:** The proposal was disapproved based on action taken on 06-64.

**608.2.2.1#1-ANDERSON.doc**

<b>Report for 06-63– 2021</b>		
<i>Committee decision: D</i>	<i>Committee Vote at Meeting: 24-0-2</i>	<i>Committee Vote on Ballot:</i>
<b>REPORT OF HEARING:</b>		
Modification (if any):		
Committee Reason: The proposal was disapproved based on action taken on 06-64.		
<b>PUBLIC COMMENT- FIRST DRAFT:</b>		
Proponent:		

<b>Report for 06-63– 2021</b>		
Desired Action:		
Modification:		
Reason:		
<b>Committee decision: AS/AM/D</b>	<b>Committee Vote at Meeting:</b>	<b>Committee Vote on Ballot:</b>
<b>REPORT OF HEARING – FIRST DRAFT</b>		
Modification (if any):		
Committee Reason:		
<b>PUBLIC COMMENT- SECOND DRAFT:</b>		
Proponent:		
Desired Action:		
Modification:		
Reason:		
<b>Committee decision: AS/AM/D</b>	<b>Committee Vote at Meeting:</b>	<b>Committee Vote on Ballot:</b>
<b>FINAL ACTION:</b>		
Modification (if any):		
Committee Reason:		

## 06-64 – 2021

### 608.2.2.1

**Proponent:** Doug Anderson, representing A117.1 Accessible Bathing Task Group

**Revise as follows:**

### SECTION 608 SHOWER COMPARTMENTS

**608.1 General.** Shower compartments shall comply with Section 608.

**608.2 Size, clearance and seat.** Shower compartments shall have sizes, clearances and seats complying with Section 608.2.

**608.2.1 Transfer-type shower compartments.** Transfer-type shower compartments shall comply with Section 608.2.1.

**608.2.2.1 Size.** Standard roll-in-type shower compartments shall have a clear inside dimension of 60 inches (1525 mm) minimum in width and 30 inches (760 mm) minimum in depth, measured at the center point of opposing sides. An entry 60 inches (1525 mm) minimum in width shall be provided.

**Exception.** Where an existing bathtub is replaced by a roll-in-type shower, the width of the shower shall be permitted to be 57.5 inches (1460 mm) minimum, provided that compliance with Section 608.2.2.1 would require an expansion in the overall size of the bathroom or would disturb the structural reinforcement of the floor slab.

---

**REASON:** This proposal is seeking to acknowledge the standard tub rough opening will not accommodate a 60” clear interior width for a roll-in shower.

The original roll-in shower size was intended to replace a tub. Tub rough opening does not allow for a finished 30x60 interior. This would achieve the original intent and allow for a more accessible bathing fixture without as extensive retrofits.

Committee Action: As submitted 20-1-3

### **REPORT OF HEARING:**

#### **Modification (if any):**

**Committee Reason:** The committee agreed that the original intent for roll-in shower size was to replace a tub. Tub rough opening for a tub does not allow for a finished 30x60 interior. This would achieve the original intent and allow for a more accessible bathing fixture without extensive retrofits.

<b>Report for 06-64- 2021</b>		
<i>Committee decision: AS</i>	<i>Committee Vote at Meeting: 20-1-3</i>	<i>Committee Vote on Ballot:</i>
<b>REPORT OF HEARING:</b>		
Modification (if any):		
Committee Reason: The committee agreed that the original intent for roll-in shower size was to replace a tub. Tub rough opening for a tub does not allow for a finished 30x60 interior. This would achieve the original intent and allow for a more accessible bathing fixture without extensive retrofits.		
<b>PUBLIC COMMENT- FIRST DRAFT:</b>		
Proponent:		
Desired Action:		
Modification:		
Reason:		
<i>Committee decision: AS/AM/D</i>	<i>Committee Vote at Meeting:</i>	<i>Committee Vote on Ballot:</i>
<b>REPORT OF HEARING – FIRST DRAFT</b>		
Modification (if any):		
Committee Reason:		
<b>PUBLIC COMMENT- SECOND DRAFT:</b>		
Proponent:		
Desired Action:		
Modification:		
Reason:		
<i>Committee decision: AS/AM/D</i>	<i>Committee Vote at Meeting:</i>	<i>Committee Vote on Ballot:</i>
<b>FINAL ACTION:</b>		
Modification (if any):		
Committee Reason:		



## **06-65 – 2021**

### **608.2.3.2(New)**

**Proponent:** Gene Boecker, Code Consultants, Inc.

**Add new text as follows:**

#### **SECTION 608 SHOWER COMPARTMENTS**

##### **608.2.3 Alternate roll-in shower compartments.....**

**608.2.3.2 Clearance.** The clearance outside the entry to an alternate roll-in type shower shall comply with the door maneuvering clearances in Section 404.2.3.4.

---

**REASON:** The standard does not indicate a clear floor space for accessible the alternate roll-in shower. In prior editions, the approach would have to be one with a minimum 36-inch accessible route. Because the opening for the alternate roll-in shower is to allow passage so that a seat transfer can occur, the opening is more like that of a door. The provisions would allow for a clear floor space to be provided to make such a passage (similar to Figure 404.2.3.4(A) or 404.2.3.4(C) depending on the approach).

---

## **06-65 – 2021 modification**

### **608.2.3.2(New)**

**Proponent:** Gene Boecker, Code Consultants, Inc.

**Further revise follows:**

#### **SECTION 608 SHOWER COMPARTMENTS**

##### **608.2.3 Alternate roll-in shower compartments.....**

**608.2.3.2 Clearance.** ~~The~~ A clearance shall be provided outside the entry to an alternate roll-in type shower ~~shall comply~~ complying with the door maneuvering clearances in ~~Section~~ Table 404.2.3.4.

---

**REASON:** The intent of this modification is to meet the same intent of the original proposal and remove a possible mis-interpretation.

The proposal as written could be interpreted to allow for an opening on less than 36". The text in Section 404.2.3.4 says "Doorways without doors or gates that are less than 36 inches....". The modification would specifically ask for the clearance based on direction the shower was accessed. Therefore the 36" opening in Section 608.2.3.1 would control.

Committee Action: As modified 24-0-0

**REPORT OF HEARING:**

**Modification (if any):**

**Further revise follows:**

**608.2.3.2 Clearance.** The A clearance shall be provided outside the entry to an alternate roll-in type shower shall ~~comply~~ complying with the door maneuvering clearances in ~~Section~~ Table 404.2.3.4.

**Committee Reason:** The proposal will provide adequate clearance outside the shower opening for access through the shower opening.

**608.2.3.2-BOECKER.doc**

<b>Report for 06-65 – 2021</b>		
<i>Committee decision: AS/AM/D</i>	<i>Committee Vote at Meeting: AM 24-0-0</i>	<i>Committee Vote on Ballot:</i>
<b>REPORT OF HEARING:</b>		
Modification (if any):		
<b>Further revise follows:</b>		
608.2.3.2 Clearance. The A clearance shall be provided outside the entry to an alternate roll-in type shower shall <del>comply</del> <u>complying</u> with the door maneuvering clearances in <del>Section</del> <u>Table</u> 404.2.3.4.		
Committee Reason: The proposal will provide adequate clearance outside the shower opening for access through the shower opening.		
<b>PUBLIC COMMENT- FIRST DRAFT:</b>		
Proponent:		
Desired Action:		
Modification:		
Reason:		
<i>Committee decision: AS/AM/D</i>	<i>Committee Vote at Meeting:</i>	<i>Committee Vote on Ballot:</i>
<b>REPORT OF HEARING – FIRST DRAFT</b>		
Modification (if any):		
Committee Reason:		
<b>PUBLIC COMMENT- SECOND DRAFT:</b>		
Proponent:		
Desired Action:		
Modification:		
Reason:		
<i>Committee decision: AS/AM/D</i>	<i>Committee Vote at Meeting:</i>	<i>Committee Vote on Ballot:</i>
<b>FINAL ACTION:</b>		
Modification (if any):		
Committee Reason:		



## 06-66 – 2021

608.4.1, 608.4.2, 608.4.3, 608.5, 609.3, Figures 608.4.1, 608.4.1(B), 608.4.3(C)(New), 608.4.3(D)(New)

**Proponent:** Kimberly Paarlberg, International Code Council

**Revise as follows:**

### SECTION 608 SHOWER COMPARTMENTS

**608.4 Controls and hand showers.** Controls and hand showers shall comply with Sections 608.4 and 309.4.

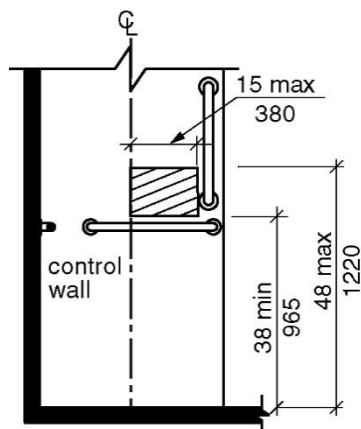
**608.4.1 Transfer-type showers.** In transfer-type showers, the on/off and temperature controls and ~~diverter-hand shower~~ shall be located according to the following:

1. On the control wall opposite the seat.
2. At a height of 38 inches (965 mm) minimum and 48 inches (1220 mm) maximum above the shower floor, ~~and,~~
3. 15 inches (380 mm) maximum, from the centerline of the control wall toward the shower opening.

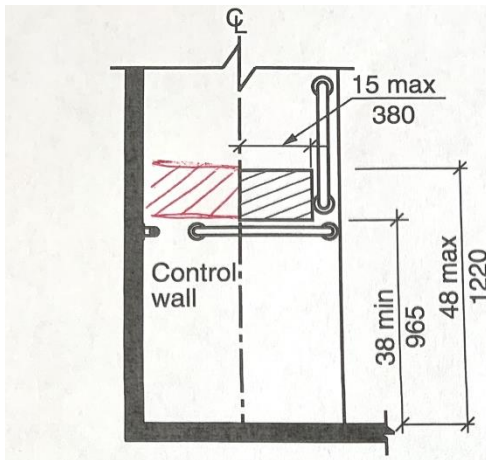
In transfer-type showers, the means to hold the hand shower shall be located according to the following:

1. On the control wall opposite the seat or on the back wall 16 inches (405 mm) minimum from the wall behind the seat.
2. At a height of 38 inches (965 mm) minimum and 48 inches (1220 mm) maximum above the shower floor.

**Exception:** The bracket to hold the hand shower shall be permitted to be mounted on a vertical bar and be adjustable in height provided the bracket can be located on that bar within the reach range.



**FIGURE 608.4.1(A)**  
**TRANSFER-TYPE SHOWER CONTROLS AND HAND SHOWER LOCATION**

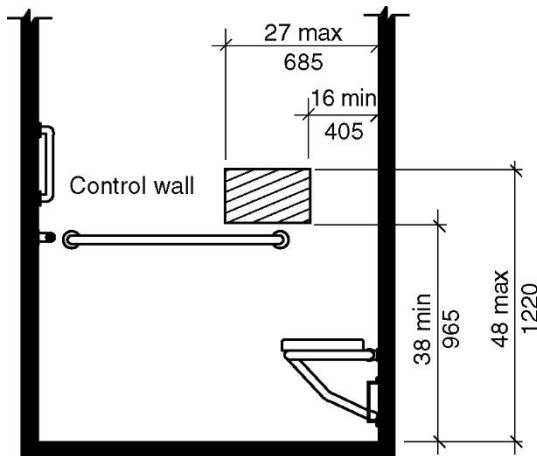


**FIGURE 608.4.1(B)**  
**TRANSFER-TYPE SHOWER HAND SHOWER LOCATION**

**608.4.2 Standard roll-in showers.** In standard roll-in showers, the on/off and temperature controls, diverters and the means to hold the hand shower shall ~~not be located above the seat.~~ ~~Controls and hand showers shall~~ be located according to the following:

1. On the back wall,
2. At a height of 38 inches (965 mm) minimum and 48 inches (1220 mm) maximum above the shower floor and
3. 16 inches (405 mm) minimum and 27 inches (685 mm) maximum from the wall behind the seat.

**Exception:** The means to hold the hand shower shall be permitted to be mounted on a vertical bar and be adjustable in height provided the bracket can be located on that bar within the reach range.



**FIGURE 608.4.2**  
**STANDARD ROLL-IN-TYPE SHOWER CONTROLS AND HAND SHOWER**  
**LOCATION**

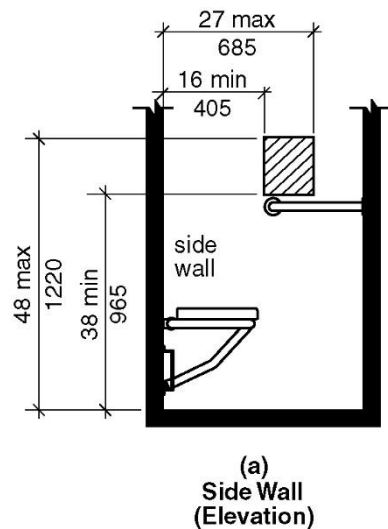
**608.4.3 Alternate roll-in showers.** In alternate roll-in showers, the on/off and temperature controls and ~~diverters and shower~~ shall be located according to the following:

1. At a height of 38 inches (965 mm) minimum and 48 inches (1220 mm) maximum above the shower floor, and
2. Where the controls and hand shower are located on the end wall adjacent to the seat, the controls and hand shower shall be 16 inches (405 mm) minimum and 27 inches (685 mm) maximum from the wall behind the seat wall, or
3. Where the controls and hand shower are located on the back wall opposite the seat, the controls and hand shower shall be located within 15 inches (380 mm) maximum from the centerline of the seat toward the transfer space.

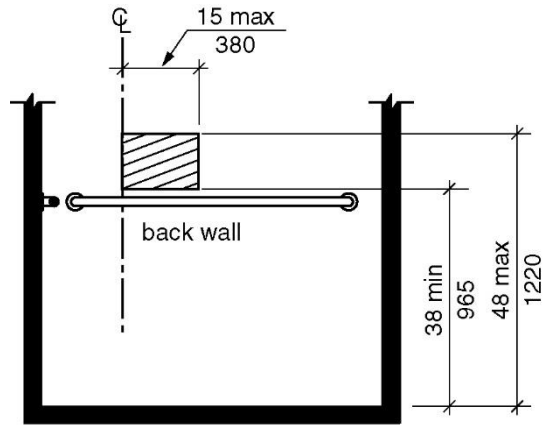
In alternate roll-in showers, a means to hold the hand shower shall be located according to the following:

1. On the back wall opposite the seat or on the side wall 16 inches (405 mm) minimum from the wall behind the seat.
2. At a height of 38 inches (965 mm) minimum and 48 inches (1220 mm) maximum above the shower floor.

**Exception:** The means to hold the hand shower shall be permitted to be mounted on a vertical bar and be adjustable in height provided the bracket can be located on that bar within the reach range.

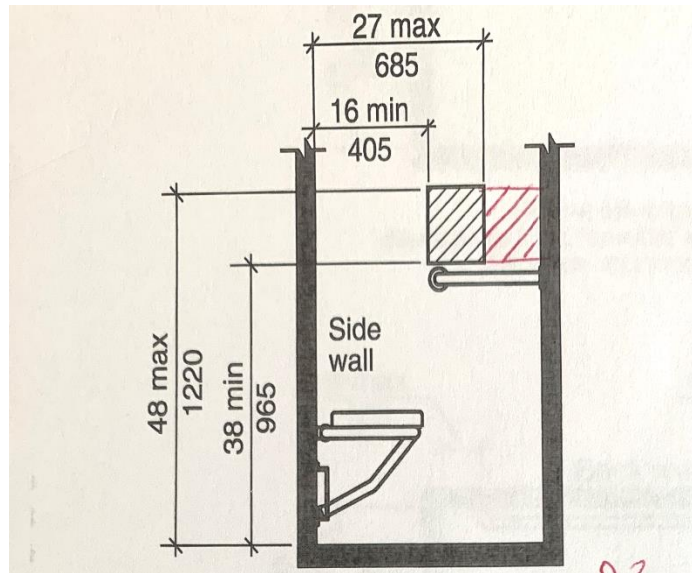


**FIGURE 608.4.3(A)**  
**ALTERNATE ROLL-IN-TYPE SHOWER CONTROLS AND ~~HAND SHOWER~~**  
**LOCATION - END WALL – ELEVATION**

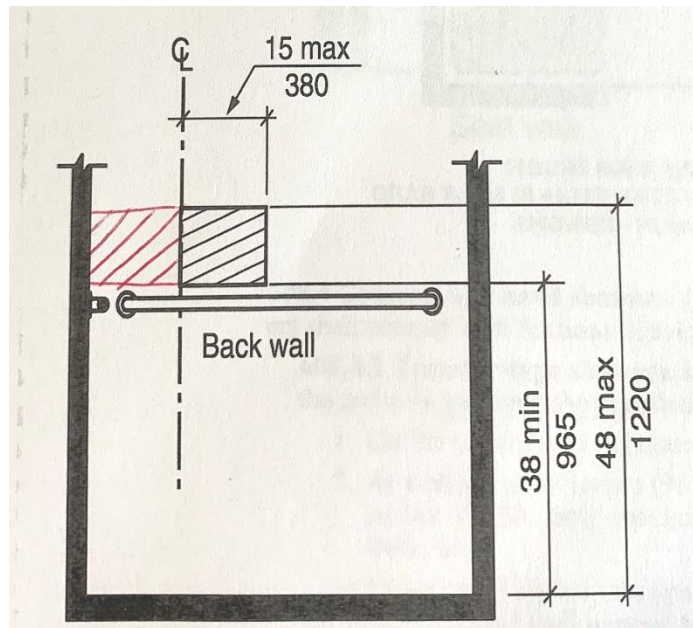


(b)  
Back Wall  
(Elevation)

**FIGURE 608.4.3(B)  
ALTERNATE ROLL-IN-TYPE SHOWER CONTROLS AND HAND SHOWER  
LOCATION - CONTROL WALL – ELEVATION**



**FIGURE 608.4.3(C) ALTERNATE ROLL-IN-TYPE SHOWER HAND SHOWER  
LOCATION - END WALL – ELEVATION**



**FIGURE 608.4.3(D)**  
**ALTERNATE ROLL-IN-TYPE SHOWER HAND SHOWER LOCATION -**  
**CONTROL WALL – ELEVATION**

**608.5 Hand showers.** A hand shower with a hose 59 inches (1500 mm) minimum in length, that can be used both as a fixed shower head and as a hand shower, shall be provided. The hand shower shall have a control with a nonpositive shut-off feature. A means to hold the hand shower ~~wand~~ while in the on or off position shall be provided and located at a height of 38 inches (965 mm) minimum and 48 inches (1220 mm) maximum above the shower finish floor according to Section 608.4. Where provided, an adjustable-height means to hold the hand shower mounted on a vertical bar shall be installed so as to not obstruct the use of grab bars. A fixed shower head, in addition to the hand shower shall be permitted

**Exception Exceptions:**

1. In other than Accessible units and Type A units, a fixed shower head located 48 inches (1220 mm) maximum above the shower floor shall be permitted in lieu of a hand shower.
2. Where the means to hold the hand shower is adjustable on a vertical bar, the vertical bar is permitted to extend above 48 inches.

**SECTION 609**  
**GRAB BARS**

**609.3 Spacing.** The space between the wall and the grab bar shall be 1½ inches (38 mm). The space between the grab bar and projecting objects below and at the ends of the grab bar shall be 1½ inches (38 mm) minimum. The space between the grab bar and projecting objects above the grab bar shall be 12 inches (305 mm) minimum.



**Exceptions:**

1. The space between the grab bars and shower/bathtub on/off and temperature controls, diverters, shower/bathtub fittings including the vertical bar for the adjustable means to hold the hand shower, and other grab bars above the grab bar shall be permitted to be 1 1/2 inches (38 mm) minimum.
2. Recessed dispensers projecting from the wall 1/4 inch (6.4 mm) maximum measured from the face of the dispenser and complying with Section 604.7 shall be permitted within the 12-inch (305 mm) space above and the 1 1/2-inch (38 mm) spaces below and at the ends of the grab bar.

**REASON:** This is for showers; there is a similar proposal for bathtubs. The intent of this proposal is to 1) leave the controls in the current location, but allow additional options for the means to hold the hand shower within reach of the seat and 2) use consistent and precise terminology and 3) coordinate current requirements. It is important that we are all using and understanding the terms in the same way -The ‘on/off and temperature controls’, depending on the system chosen, can be one, two or three handles. This controls the water flow and the temperature of the water.

The ‘diverter’ is for situations where there is both a fixed shower head and a hand held shower. The diverter can also be used to change the water spray to a variety of devices, such as back sprays or tub spouts. I have spoken with a group of ICC plumbing experts on what would be involved for relocating the diverter or providing additional sets of controls. Basically the response was extensive added plumbing behind the wall, or in some scenarios, cannot be done without options way past standard plumbing.

The hand shower consists of the 59” hose and the hand shower head. A means to turn the water on and off (non-positive shut off valve) is required on the shower head. The ‘means to hold the hand shower head’ can be a bracket on the wall or a sliding bracket on a vertical pole. The figures would be in addition to the current to show the options for the means to hold the hand shower head.

The changes to 608.5 is to keep the information for hand showers in one location – currently we have it mixed up in both. The exception indicates that a slider bar can be used for adjustment.

The changes to 609.3 is to clarify what ‘not obstruct the grab bar’ means.

Committee Action: Disapproval 25-0-0

**REPORT OF HEARING:**

**Modification (if any):**

**Committee Reason:** The committee agreed that the replacement proposal to 06-47 will address issues in items 06-47, 06-48, 06-49, 06-51, 06-52, 06-66, 06-68.

**608.4-PAARLBERG.doc**

<b>Report for 06-66– 2021</b>		
<i>Committee decision: D</i>	<i>Committee Vote at Meeting: 25-0-0</i>	<i>Committee Vote on Ballot:</i>

<b>Report for 06-66– 2021</b>		
<b>REPORT OF HEARING:</b>		
Modification (if any):		
Committee Reason: The committee agreed that the replacement proposal to 06-47 will address issues in items 06-47, 06-48, 06-49, 06-51, 06-52, 06-66, 06-68.		
<b>PUBLIC COMMENT- FIRST DRAFT:</b>		
Proponent:		
Desired Action:		
Modification:		
Reason:		
<b>Committee decision: AS/AM/D</b>	<b>Committee Vote at Meeting:</b>	<b>Committee Vote on Ballot:</b>
<b>REPORT OF HEARING – FIRST DRAFT</b>		
Modification (if any):		
Committee Reason:		
<b>PUBLIC COMMENT- SECOND DRAFT:</b>		
Proponent:		
Desired Action:		
Modification:		
Reason:		
<b>Committee decision: AS/AM/D</b>	<b>Committee Vote at Meeting:</b>	<b>Committee Vote on Ballot:</b>
<b>FINAL ACTION:</b>		
Modification (if any):		
Committee Reason:		

## 06-67 – 2021

### 608.4.1, Figure 608.4.1

**Proponent:** Doug Anderson, representing A117.1 Accessible Bathing Task Group

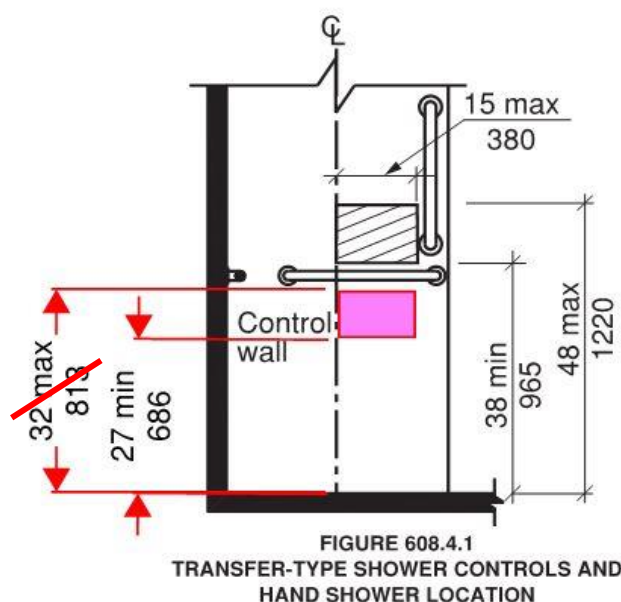
**Revise as follows:**

#### SECTION 608 SHOWERS

**608.4.1 Transfer-type showers.** In transfer-type showers, the controls and hand shower shall be located:

1. On the control wall opposite the seat.
2. Hand showers can be located at ~~A~~ a height of 38 inches (965 mm) minimum and 48 inches (1220 mm) maximum above the shower floor, ~~and~~
3. Controls can be located at a height of 27 inches (686 mm) minimum and 48 inches (1220 mm) maximum above the shower floor, and
3. 4. 15 inches (380 mm) maximum, from the centerline of the control wall toward the shower opening.

*Note: Revise figure to include additional control location.*



**REASON:** This proposal provides an alternate location for hand controls under the required grab bars would help users and reduce the risk of fall. Section 609.3 would require the entire control to be 1-1/2" above or below the grab bar. This would be consistent with the approach used for bathtub controls below the grab bar.

Committee Action: Modification to add this same allowance to Section 608.4.3 Item 3 26-0-0  
Approved as Modified – 26-0-0

**REPORT OF HEARING:**

**Modification (if any):**

**Further revise as follows:**

*Note: This proposal and modification will be coordinated with 06-47-2021 AM*

**608.4.3 Alternate roll-in showers.** In alternate roll-in showers, the controls and hand shower shall be located in accordance with one of the following:

- ~~1.~~ At a height of 38 inches (965 mm) minimum and 48 inches (1220 mm) maximum above the shower floor, and
- ~~1.2.~~ Where the controls and hand shower are located on the end wall adjacent to the seat, the controls and hand shower shall be located:
  - 1.1. At a height of 38 inches (965 mm) minimum and 48 inches (1220 mm) maximum above the shower floor
  - 1.2 16 inches (405 mm) minimum and 27 inches (685 mm) maximum from the wall behind the seat wall, or
- ~~2.3.~~ Where the controls and hand shower are located on the back wall opposite the seat,
  - 2.1. Hand showers can be located at a height of 38 inches (965 mm) minimum and 48 inches (1220 mm) maximum above the shower floor.
  - 2.2. Controls can be located at a height of 27 inches (686 mm) minimum and 48 inches (1220 mm) maximum above the shower floor, and
  - 2.3. the controls and hand shower shall be located within 15 inches (380 mm) maximum from the centerline of the seat toward the transfer space.

**Committee Reason:** The modification was to increase the locations permitted for controls for the wall across from the seat in alternate roll-in showers the same as the proposal for transfer showers. The committee felt that this increased area for controls is within reach of the seat and would not obstruct knee clearances. Under the grab bar is consistent with tub controls, so it should be reachable. This expansion of control areas needs to be coordinated with the allowances approved by the replacement to 06-47 – so the committee approved the intent understanding this will look different in the final draft since controls and hand shower locations are not split into two sections.

**608.4.1-ANDERSON.doc**

<b>Report for 06-67– 2021</b>		
<b>Committee decision: AM</b>	<b>Committee Vote at Meeting: 26-0-0</b>	<b>Committee Vote on Ballot:</b>
<b>REPORT OF HEARING:</b> Modification (if any): <b>Further revise as follows:</b> <i>Note: This modification will be coordinated with 06-47-2021 AM</i>		
<b>608.4.3 Alternate roll-in showers.</b> In alternate roll-in showers, the controls and hand shower shall be located <u>in accordance with one of the following::</u> <ol style="list-style-type: none"><li><del>1.</del> <u>At a height of 38 inches (965 mm) minimum and 48 inches (1220 mm) maximum above the shower floor, and</u></li><li><del>1.2.</del> <u>Where the controls and hand shower are located on the end wall adjacent to the seat, the controls and hand shower shall be located:</u><ol style="list-style-type: none"><li><u>1.1. At a height of 38 inches (965 mm) minimum and 48 inches (1220 mm) maximum above the shower floor</u></li><li><u>1.2 16 inches (405 mm) minimum and 27 inches (685 mm) maximum from the wall behind the seat wall, or</u></li></ol></li></ol>		

**Report for 06-67– 2021**

2.3. Where the controls and hand shower are located on the back wall opposite the seat.

2.1. Hand showers can be located at a height of 38 inches (965 mm) minimum and 48 inches (1220 mm) maximum above the shower floor.

2.2. Controls can be located at a height of 27 inches (686 mm) minimum and 48 inches (1220 mm) maximum above the shower floor, and

2.3. the controls and hand shower shall be located within 15 inches (380 mm) maximum from the centerline of the seat toward the transfer space.

Committee Reason: The modification was to increase the locations permitted for controls for the wall across from the seat in alternate roll-in showers the same as the proposal for transfer showers. The committee felt that this increased area for controls is within reach of the seat and would not obstruct knee clearances. Under the grab bar is consistent with tub controls, so it should be reachable. This expansion of control areas needs to be coordinated with the allowances approved by the replacement to 06-47 – so the committee approved the intent understanding this will look different in the final draft since controls and hand shower locations are not split into two sections.

**PUBLIC COMMENT- FIRST DRAFT:**

Proponent:

Desired Action:

Modification:

Reason:

**Committee decision: AS/AM/D**

**Committee Vote at Meeting:**

**Committee Vote on Ballot:**

**REPORT OF HEARING – FIRST DRAFT**

Modification (if any):

Committee Reason:

**PUBLIC COMMENT- SECOND DRAFT:**

Proponent:

Desired Action:

Modification:

Reason:

**Committee decision: AS/AM/D**

**Committee Vote at Meeting:**

**Committee Vote on Ballot:**

**FINAL ACTION:**

Modification (if any):

Committee Reason:

## 06-68 – 2021

### 608.4.2

**Proponent:** Hope Reed, ADA Accessibility Consultant, representing self

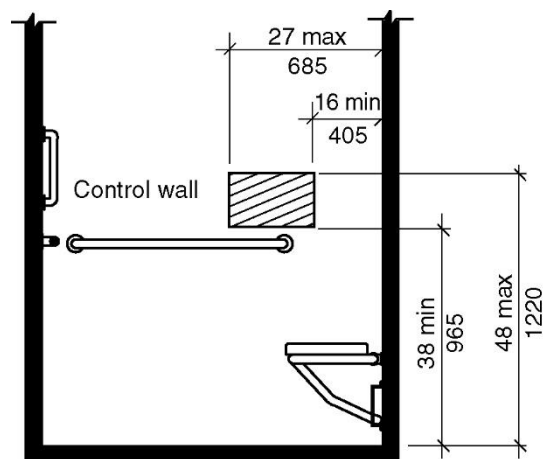
**Revise as follows:**

### SECTION 608

#### SHOWERS

**608.4.2 Standard roll-in showers.** In standard roll-in showers, the controls, ~~and~~ hand shower and other elements shall not be located above the seat. Controls, diverters, and hand showers shall be located according to the following:

1. On the back wall.
2. At a height of 38 inches (965 mm) minimum and 48 inches (1220 mm) maximum above the bathtub floor and
3. 16 inches (405 mm) minimum and 27 inches (685 mm) maximum from the wall behind the seat.



**FIGURE 608.4.2**  
**STANDARD ROLL-IN-TYPE SHOWER CONTROLS AND**  
**HAND SHOWER LOCATION**

**REASON:** Provide controls *for* people using the permanent seat and a wall mounted shower head *for* those who stand, with support of the grab bars, while showering. Serve varying levels of disability and allow a standard showering set up for the care giver, spouse, and friend who will also be sharing the accessible bathroom. Controls at the seated location are essential because a person who stands while showering can easily reach and adjust the diverter and water temperature at the back wall control area.

Committee Action: Disapproval 25-0-0

**REPORT OF HEARING:**

**Modification (if any):**

**Committee Reason:** The committee agreed that the replacement proposal to 06-47 will address issues in items 06-47, 06-48, 06-49, 06-51, 06-52, 06-66, 06-68.

**608.4.2.REED.doc**

<b>Report for 06-68– 2021</b>		
<i>Committee decision: D</i>	<i>Committee Vote at Meeting: 25-0-0</i>	<i>Committee Vote on Ballot:</i>
<b>REPORT OF HEARING:</b>		
Modification (if any):		
Committee Reason: The committee agreed that the replacement proposal to 06-47 will address issues in items 06-47, 06-48, 06-49, 06-51, 06-52, 06-66, 06-68.		
<b>PUBLIC COMMENT- FIRST DRAFT:</b>		
Proponent:		
Desired Action:		
Modification:		
Reason:		
<i>Committee decision: AS/AM/D</i>	<i>Committee Vote at Meeting:</i>	<i>Committee Vote on Ballot:</i>
<b>REPORT OF HEARING – FIRST DRAFT</b>		
Modification (if any):		
Committee Reason:		
<b>PUBLIC COMMENT- SECOND DRAFT:</b>		
Proponent:		
Desired Action:		
Modification:		
Reason:		
<i>Committee decision: AS/AM/D</i>	<i>Committee Vote at Meeting:</i>	<i>Committee Vote on Ballot:</i>
<b>FINAL ACTION:</b>		
Modification (if any):		
Committee Reason:		

## 06-69 – 2021

### 608.5

**Proponent:** Hope Reed, ADA Accessibility Consultant, representing self

**Revise as follows:**

#### SECTION 608 SHOWERS

**608.5 Hand showers.** A hand shower with a hose 59 inches (1500mm) minimum in length, that can be used both as a fixed shower head and as a hand shower, shall be provided. The hand shower shall have a control with a nonpositive shut-off feature that complies with 309.4. Where provided, an adjustable-height hand shower mounted on a vertical bar shall be installed so as not to obstruct the use of grab bars. A means to hold the shower wand while in the on or off position shall be located at a height of 38 inches (965 mm) minimum and 48 inches (1220 mm) maximum above the shower floor. The hand shower wand shall be configured to allow adjustment of the water spray direction and limit rotation during use.

**Exception:** In other than Accessible units and Type A units, a fixed shower head located 48 inches (1220 mm) maximum above the shower floor shall be permitted in lieu of a hand shower.

**REASON:** The hose for hand shower wands is usually twisted and when water pressure comes on it becomes even more twisted. When the spray wand is attached to a vertical bar and water is turned on it may then rotate even further within the mounting. A round mount and round spray wand handle cannot be secured, especially when wet. Often the spray wand can spray in only one direction from its attachment. A person with disabilities who stands while showering may have to hover in the back corner and get only a small, small portion of the spray, or they may have to stand where they can block the water from spraying out into the room. *See alternate proposal we provided with 608.S(b).*

Committee Action: The proposal was slit between the revisions to the 2<sup>nd</sup> and the new 4<sup>th</sup> sentence.

Part 1 – Revision to 2<sup>nd</sup> sentence – AS 11-9-1

Part 2 – Addition of 4<sup>th</sup> sentence – D 20-3-0

#### REPORT OF HEARING:

**Modification (if any):**

**Replace with the following:**

**608.5 Hand showers.** A hand shower with a hose 59 inches (1500mm) minimum in length, that can be used both as a fixed shower head and as a hand shower, shall be provided. The hand



shower shall have a control with a nonpositive shut-off feature that complies with 309.4. Where provided, an adjustable-height hand shower mounted on a vertical bar shall be installed so as not to obstruct the use of grab bars. A means to hold the shower wand while in the on or off position shall be located at a height of 38 inches (965 mm) minimum and 48 inches (1220 mm) maximum above the shower floor.

**Exception:** In other than Accessible units and Type A units, a fixed shower head located 48 inches (1220 mm) maximum above the shower floor shall be permitted in lieu of a hand shower.

**Committee Reason:** The committee felt that it was appropriate to ask for a non-positive shut off valve to meet Section 309.4 instead of all of Section 309 since the shower head is intended to be hand held and not fixed. There was a discussion about if specific provisions over ride general requirements or not. The intent is that the more specific provisions would override the general provisions for operable parts (i.e., clear floor space, reach, and operation).

The addition of the last sentence was disapproved because the committee felt that the language was too open for interpretation and unenforceable.

608.5a-REED.doc

<b>Report for 06-69- 2021</b>		
<i>Committee decision: AS &amp; D</i>	<i>Committee Vote at Meeting: 11-9-1 &amp; 20-3-0</i>	<i>Committee Vote on Ballot:</i>
<b>REPORT OF HEARING:</b>		
Modification (if any):		
<b>Replace with the following:</b>		
<b>608.5 Hand showers.</b> A hand shower with a hose 59 inches (1500mm) minimum in length, that can be used both as a fixed shower head and as a hand shower, shall be provided. The hand shower shall have a control with a nonpositive shut-off feature <u>that complies with 309.4</u> . Where provided, an adjustable-height hand shower mounted on a vertical bar shall be installed so as not to obstruct the use of grab bars. A means to hold the shower wand while in the on or off position shall be located at a height of 38 inches (965 mm) minimum and 48 inches (1220 mm) maximum above the shower floor.		
<b>Exception:</b> In other than Accessible units and Type A units, a fixed shower head located 48 inches (1220 mm) maximum above the shower floor shall be permitted in lieu of a hand shower.		
Committee Reason: The committee felt that it was appropriate to ask for a non-positive shut off valve to meet Section 309.4 instead of all of Section 309 since the shower head is intended to be hand held and not fixed. There was a discussion about if specific provisions over ride general requirements or not. The intent is that the more specific provisions would override the general provisions for operable parts (i.e., clear floor space, reach, and operation).		
The addition of the last sentence was disapproved because the committee felt that the language was too open for interpretation and unenforceable.		
<b>PUBLIC COMMENT- FIRST DRAFT:</b>		
Proponent:		
Desired Action:		
Modification:		
Reason:		
<i>Committee decision: AS/AM/D</i>	<i>Committee Vote at Meeting:</i>	<i>Committee Vote on Ballot:</i>
<b>REPORT OF HEARING – FIRST DRAFT</b>		
Modification (if any):		
Committee Reason:		
<b>PUBLIC COMMENT- SECOND DRAFT:</b>		
Proponent:		
Desired Action:		
Modification:		
Reason:		
<i>Committee decision: AS/AM/D</i>	<i>Committee Vote at Meeting:</i>	<i>Committee Vote on Ballot:</i>
<b>FINAL ACTION:</b>		
Modification (if any):		
Committee Reason:		

## 06-70 – 2021

### 608.5

**Proponent:** Hope Reed, ADA Accessibility Consultant, representing self

**Revise as follows:**

#### SECTION 608 SHOWERS

**608.5 Hand showers.** A hand shower with a hose 59 inches (1500mm) minimum in length, that can be used both as a fixed shower head and as a hand shower, shall be provided. The hand shower shall have a control with a nonpositive shut-off feature that complies with 309.4. Where provided, an adjustable-height hand shower mounted on a vertical bar shall be installed so as to not obstruct the use of grab bars. A means to hold the shower wand while in the on or off position shall be located at a height of 38 inches (965 mm) minimum and 48 inches (1220 mm) maximum above the shower floor. The hand shower mount shall require the hand shower water spray to be directed without rotating during use and shall be located according to the following:

1. On the back wall,
2. At a height of 38 inches (965 mm) minimum and 48 inches (1220 mm) maximum above the shower floor and
3. 16 inches (405 mm) minimum and 27 inches (685 mm) maximum from the wall behind the seat.

**Exception:** In other than Accessible units and Type A units, a fixed shower head located 48 inches (1220 mm) maximum above the shower floor shall be permitted in lieu of a hand shower.

**REASON:** The hose for hand shower wands is usually twisted and when water pressure comes on it becomes even more twisted. When the spray wand is attached to a vertical bar and water is turned on it may then rotate even further within the mounting. A round mount and round spray wand handle cannot be secured, especially when wet. Often the spray wand can spray in only one direction from its attachment. A person with disabilities who stands while showering may have to hover in the back corner and get only a small, small portion of the spray, or they may have to stand where they can block the water from spraying out into the room. *See alternate proposal we provided with 608.5(a).*

Staff Note: 06-55 and 06-70 were both dispensed with one vote.

Committee Action: Disapproved 29-3-1

#### REPORT OF HEARING:

**Modification (if any):**

**Committee Reason:** This proposal was disapproved because the vague language would not be uniformly enforceable. In addition, rotation of the hand held shower is a convenience issue, not an accessibility issue.

608.5b-REED.doc

<b>Report for 06-70– 2021</b>		
<i>Committee decision: D</i>	<i>Committee Vote at Meeting: 29-3-1</i>	<i>Committee Vote on Ballot:</i>
<b>REPORT OF HEARING:</b>		
Modification (if any):		
Committee Reason: This proposal was disapproved because the vague language would not be uniformly enforceable. In addition, rotation of the hand held shower is a convenience issue, not an accessibility issue.		
<b>PUBLIC COMMENT- FIRST DRAFT:</b>		
Proponent:		
Desired Action:		
Modification:		
Reason:		
<i>Committee decision: AS/AM/D</i>	<i>Committee Vote at Meeting:</i>	<i>Committee Vote on Ballot:</i>
<b>REPORT OF HEARING – FIRST DRAFT</b>		
Modification (if any):		
Committee Reason:		
<b>PUBLIC COMMENT- SECOND DRAFT:</b>		
Proponent:		
Desired Action:		
Modification:		
Reason:		
<i>Committee decision: AS/AM/D</i>	<i>Committee Vote at Meeting:</i>	<i>Committee Vote on Ballot:</i>
<b>FINAL ACTION:</b>		
Modification (if any):		
Committee Reason:		

## 06-71 – 2021

### 608.6, 608.6.1(New)

**Proponent:** Stanley Wyche Ross, representing State of New Mexico Governor's Commission on Disability

**Revise as follows:**

#### SECTION 608 SHOWERS

**608.6 Shower floor and threshold.** The shower floor and threshold shall comply with Section 608.6.

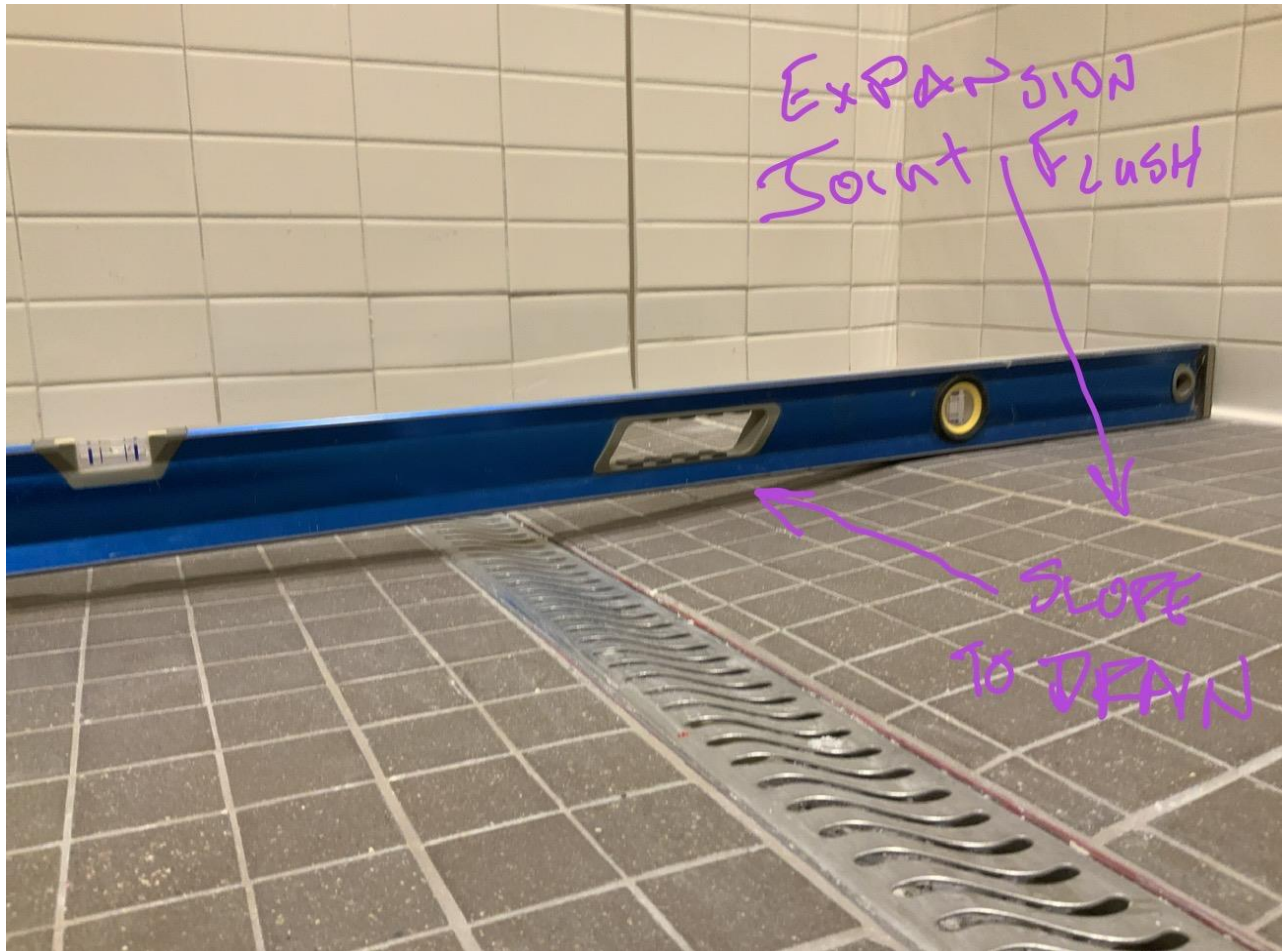
**608.6.1 Shower floor.** The slope of the required shower floor size shall not exceed 1:48 in all directions. The floor drains shall comply with Section 302.3. Changes in level are permitted only at the threshold strip.

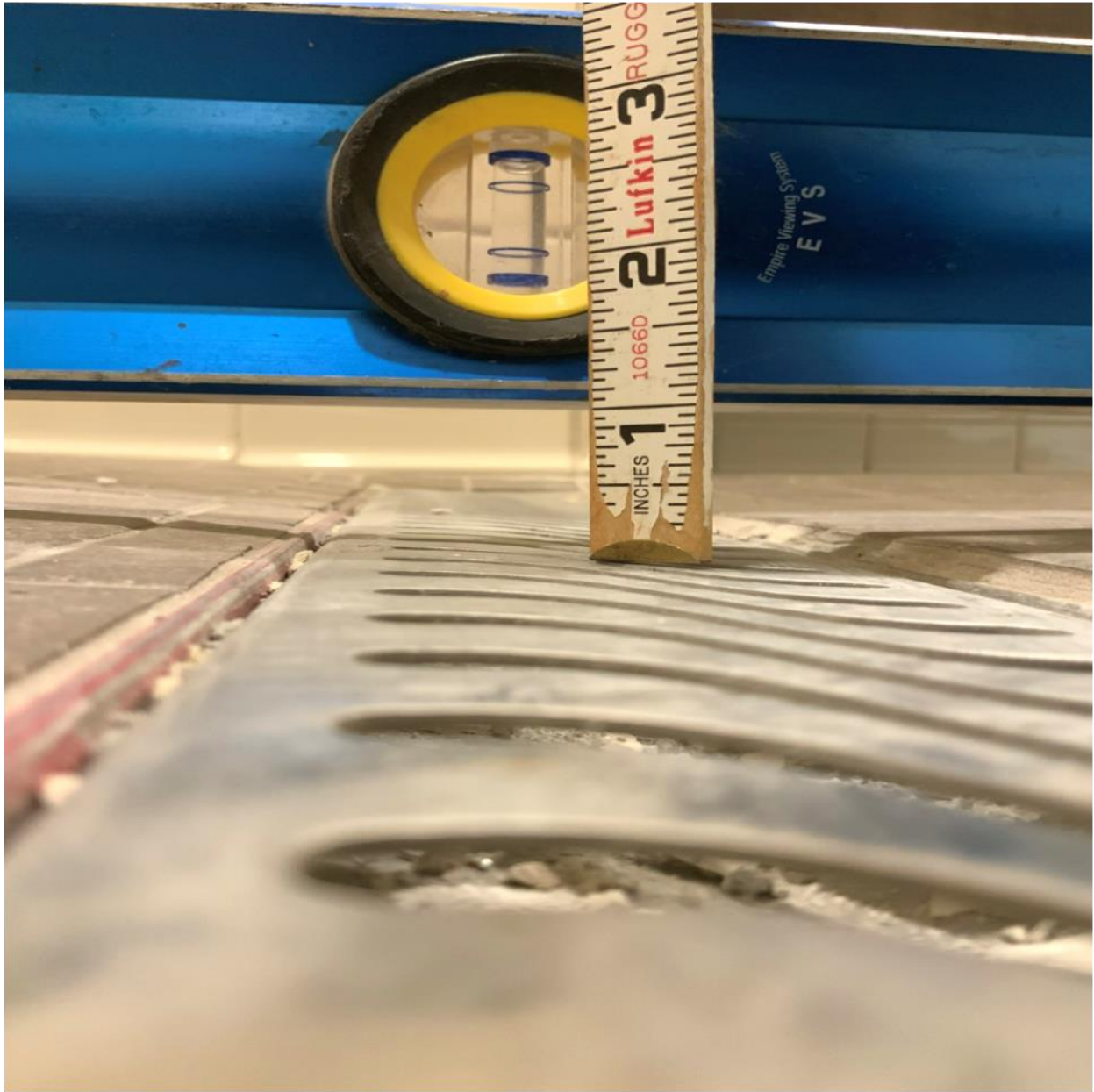
**608.6.2 Threshold.** The threshold shall be located within a 4 inch (102 mm) wide strip along entry side of the shower, or sides of the shower. This 4 inch (102 mm) wide strip shall be centered along the shower floor size line. Threshold in roll-in-type shower compartments shall be 1/2 inch (13mm) maximum in height in accordance with Section 303. In transfer-type shower compartments, thresholds 1/2 inch (13mm) maximum in height shall be beveled, rounded, or vertical.

**Exception:** In existing facilities, in transfer-type shower compartments where provision of a threshold 1/2 inch (13 mm) in height would disturb the structural reinforcement of the floor slab, a threshold 2 inches (51 mm) maximum in height shall be permitted.

---

**REASON:** The required shower floor size needs specific slope standards. Identify 1 :48 maximum slopes within the required shower floor area similar to Section 502.5 parking area slopes. Also include a specific location for the threshold strip. The threshold could overlap the clearance between the clear floor area and shower seat. See attached photos of a recent shower install. We had to use the "Guidance on ADA" to help explain threshold requirements to the builder.





This is a short video.



20210122\_095947\_v  
ideo\_20210122\_0959

Committee Action: Disapproved 24-1-0

**REPORT OF HEARING:**

**Modification (if any):**

**Committee Reason:** As written, this proposal would limit the allowances needed for good shower drainage. The issue is different for central drains versus threshold or back wall pan drains.

608.6-ROSS.doc

<b>Report for 06-71– 2021</b>		
<i>Committee decision: D</i>	<i>Committee Vote at Meeting: 24-1-0</i>	<i>Committee Vote on Ballot:</i>
<b>REPORT OF HEARING:</b>		
Modification (if any):		
Committee Reason: As written, this proposal would limit the allowances needed for good shower drainage. The issue is different for central drains versus threshold or back wall pan drains.		
<b>PUBLIC COMMENT- FIRST DRAFT:</b>		
Proponent:		
Desired Action:		
Modification:		
Reason:		
<i>Committee decision: AS/AM/D</i>	<i>Committee Vote at Meeting:</i>	<i>Committee Vote on Ballot:</i>
<b>REPORT OF HEARING – FIRST DRAFT</b>		
Modification (if any):		
Committee Reason:		
<b>PUBLIC COMMENT- SECOND DRAFT:</b>		
Proponent:		
Desired Action:		
Modification:		
Reason:		
<i>Committee decision: AS/AM/D</i>	<i>Committee Vote at Meeting:</i>	<i>Committee Vote on Ballot:</i>
<b>FINAL ACTION:</b>		
Modification (if any):		
Committee Reason:		



## **06-72 – 2021**

**608.7, 1103.5, 1103.11.2.5, 1103.11.2.5.3(New), 1104.11.3.1.3, 1104.11.3.1.3.3, 1104.11.3.1.3.4(New), 1104.11.3.2.3, 1104.11.3.2.3.3(New)**

**Proponent:** Kimberly Paarlberg, International Code Council

**Revise as follows:**

### **SECTION 607 BATHTUBS**

**607.7 Bathtub enclosures.** Enclosures for bathtubs shall not obstruct controls, faucets, shower and spray units or obstruct transfer from wheelchairs onto bathtub seats or into bathtubs. Enclosures on bathtubs shall not have tracks installed on the rim of the bathtub.

### **SECTION 608 SHOWERS**

**608.7 Shower enclosures.** Shower compartment enclosures for shower compartments shall not obstruct controls or obstruct transfer from wheelchairs onto shower seats. Track for enclosures on showers shall comply with the threshold requirement in Section 608.6.

### **SECTION 1102 ACCESSIBLE UNITS**

**1102.11.2 Toilet and bathing facility.** At least one toilet and bathing facility shall comply with Section 603. At least one lavatory, one water closet and either a bathtub or shower within the unit shall comply with Sections 604 through 610. These toilet and bathing fixtures shall be in a single toilet/bathing area, such that travel between fixtures does not require travel through other parts of the unit.

### **SECTION 1103 TYPE A UNITS**

**1103.5 Doors and doorways.** The primary entrance door to the unit, and all other doorways intended for user passage, shall comply with Section 404.

**Exceptions:**

1. Thresholds at exterior sliding doors shall be permitted to be  $\frac{3}{4}$  inch (19 mm) maximum in height, provided they are beveled with a slope not greater than 1:2.
2. In toilet rooms and bathrooms not required to comply with Section 1103.11.2, maneuvering clearances required by Section 404.2.3 shall not be required on the toilet room or bathroom side of the door.
3. A turning space between doors in a series as required by Section 404.2.5 is not required.
4. Storm and screen doors shall not be required to comply with Section 404.2.5.



5. Communicating doors between individual sleeping units shall not be required to comply with Section 404.2.5.
6. At other than the primary entrance door, where exterior space dimensions of balconies are less than the required maneuvering clearance, door maneuvering clearance is not required on the exterior side of the door.
7. The maneuvering clearances required by Section 404 shall not be required within a closet or pantry complying with Exception 2 of Section 1103.3.2.
8. Doors that are part of a shower enclosure are not required to comply with this section.

**1103.11.2.5 Bathing fixtures.** The bathing fixture shall be a bathtub complying with Section 1103.11.2.5.1 or a shower compartment complying with Section 1103.11.2.5.2. Bathtub and shower enclosures shall comply with Section 1103.11.2.5.3.

**1103.11.2.5.1 Bathtub.** Bathtubs shall comply with Section 607.

**Exception:** Countertops and cabinetry shall be permitted at one end of the clearance, provided the following criteria are met:

1. The countertop and cabinetry can be removed;
2. The floor finish extends under the countertop and cabinetry; and
3. The walls behind and surrounding the countertop and cabinetry are finished.

**1103.11.2.5.2 Shower.** Showers shall comply with Section 608.

**Exception:** At standard roll-in shower compartments complying with Section 608.2.2, lavatories, countertops and cabinetry shall be permitted at one end of the clearance, provided the following criteria are met:

1. The countertop and cabinetry can be removed;
2. The floor finish extends under the countertop and cabinetry; and
3. The walls behind and surrounding the countertop and cabinetry are finished.

**1103.11.2.5.3 Bathtub or shower enclosures.** A bathtub or shower enclosure shall be permitted where the assembly on the side of the bathtub or shower where the clearance is provided can be removed without removal or replacement of the surrounding walls and floor to which it is affixed.

## SECTION 1104 TYPE B UNITS (Option A and Option B)

**1104.5.2 User passage doorways.** Doorways intended for user passage shall comply with Section 1104.5.2.

**Exception:** Doors that are part of a shower ~~door assembly~~ enclosure shall not be required to comply with this section.

**1104.11.3.1.3 Bathing fixtures.** Where provided, a bathtub shall comply with Section 1104.11.3.1.3.1 or 1104.11.3.1.3.2 and a shower compartment shall comply with Section 1104.11.3.1.3.3. Bathtub and shower enclosures shall comply with Section 1104.11.3.1.3.4.

**1104.11.3.1.3.1 Parallel approach bathtubs.** A clearance 60 inches (1525 mm) minimum in length and 30 inches (760 mm) minimum in width shall be provided in front of bathtubs with a parallel approach. Lavatories complying with Section 606 shall be permitted in the clearance. A lavatory complying with Section 1104.11.3.1.1 shall be permitted at one end of the bathtub if a clearance 48 inches (1220 mm) minimum in length and 30 inches (760 mm) minimum in width is provided in front of the bathtub.

**1104.11.3.1.3.2 Forward approach bathtubs.** A clearance 60 inches (1525 mm) minimum in length and 48 inches (1220 mm) minimum in width shall be provided in front of bathtubs with a forward approach. A water closet and a lavatory shall be permitted in the clearance at one end of the bathtub.

**1104.11.3.1.3.3 Shower compartment.** If a shower compartment is the only bathing facility, the shower compartment shall have dimensions of 36 inches (915 mm) minimum in width and 36 inches (915 mm) minimum in depth. A clearance of 48 inches (1220 mm) minimum in length, measured perpendicular from the control wall, and 30 inches (760 mm) minimum in depth, measured from the face of the shower compartment, shall be provided.

**Exceptions Exception:**

1. A shower compartment with dimensions of 30 inches (760 mm) minimum in depth and 44 inches (1120 mm) minimum in width shall be permitted.
2. ~~A shower door assembly shall be permitted where the assembly can be removed without removal or replacement of the surrounding walls and floor to which it is affixed.~~

**1104.11.3.1.3.4 Bathtub or shower enclosures.** A bathtub or shower enclosure shall be permitted where the assembly on the side of the bathtub or shower where the clearance is provided can be removed without removal or replacement of the surrounding walls and floor to which it is affixed.

**1104.11.3.2.3 Bathing fixtures.** The bathing fixture shall be a bathtub complying with Section 1104.11.3.2.3.1 or a shower compartment complying with Section 1104.11.3.2.3.2. Bathtub and shower enclosures shall comply with Section 1104.11.3.2.3.3.

**1104.11.3.2.3.1 Bathtub.** A clearance 48 inches (1220 mm) minimum in length measured perpendicular from the control end of the bathtub, and 30 inches (760 mm) minimum in width shall be provided in front of bathtubs.

**1104.11.3.2.3.2 Shower compartment.** A shower compartment shall comply with Section 1104.11.3.1.3.3.

**1104.11.3.2.3.3 Bathtub or shower enclosures.** A bathtub or shower enclosure shall comply with Section 1104.11.3.1.3.4

**REASON:** The purpose of this change is to clarify the requirements for bathtub/shower and shower enclosure that use doors (swinging or sliding) instead of curtains to limit the spread of the water. Shower enclosures are addressed already for Type B units, but we did not clarify bathtub/shower type units. While tracks for shower doors are addressed at bathtub edges, we are silent for showers with tracks.

Type A and Type B units are permanent housing, so within those units, removal of the enclosure should be permitted as an adaptation similar to cabinet removal in Type A units. Sliding doors are often used on showers to increase access into the room and to be in front of the shower. Shower doors of this type will not provide the 32” clear width of regular doors. Since a lot of slip and falls happen in your own bathroom, allowing for tub and shower enclosure is an important safety allowance.

I would like to get some better input from HUD on what is expected for enclosures in the FHAG.

Committee Action: Mod to 608.7 – 15-5-1; As modified 18-2-1

**REPORT OF HEARING:**

**Modification (if any):**

**Further modify as follows:**

**608.7 Shower enclosures.** Shower compartment enclosures for shower compartments shall not obstruct controls or obstruct transfer from wheelchairs onto shower seats. ~~Track for enclosures on showers shall comply with the threshold requirement in Section 608.6.~~

**Committee Reason:** The modification to delete the last sentence of Section 608.7 was because threshold requirements are already addressed in the current text, so this pointer is not needed. The committee agreed that this change clarifies the requirements for bathtub/shower and shower enclosure that use doors (swinging or sliding) instead of curtains to limit the spread of the water.

**607.7 et al-PAARLBERG.doc**

<b>Report for 06-72– 2021</b>		
<b>Committee decision: AM</b>	<b>Committee Vote at Meeting: 18-2-1</b>	<b>Committee Vote on Ballot:</b>
<b>REPORT OF HEARING:</b>		
Modification (if any):		
<b>Further modify as follows:</b>		
<b>608.7 Shower enclosures.</b> Shower compartment enclosures for shower compartments shall not obstruct controls or obstruct transfer from wheelchairs onto shower seats. <del>Track for enclosures on showers shall comply with the threshold requirement in Section 608.6.</del>		
Committee Reason: The modification to delete the last sentence of Section 608.7 was because threshold requirements are already addressed in the current text, so this pointer is not needed. The committee agreed that this change clarifies the requirements for bathtub/shower and shower enclosure that use doors (swinging or sliding) instead of curtains to limit the spread of the water.		
<b>PUBLIC COMMENT- FIRST DRAFT:</b>		
Proponent:		
Desired Action:		
Modification:		
Reason:		
<b>Committee decision: AS/AM/D</b>	<b>Committee Vote at Meeting:</b>	<b>Committee Vote on Ballot:</b>
<b>REPORT OF HEARING – FIRST DRAFT</b>		
Modification (if any):		
Committee Reason:		
<b>PUBLIC COMMENT- SECOND DRAFT:</b>		
Proponent:		

<b>Report for 06-72– 2021</b>		
Desired Action:		
Modification:		
Reason:		
<b>Committee decision: AS/AM/D</b>	<b>Committee Vote at Meeting:</b>	<b>Committee Vote on Ballot:</b>
<b>FINAL ACTION:</b>		
Modification (if any):		
Committee Reason:		

## 06-73 – 2021

608.9(New), 608.9.1(New), 608.9.2(New), 608.9.3(New)

**Proponent:** Doug Anderson, representing A117.1 Accessible Bathing Task Group

**Add new text as follows:**

### SECTION 608 SHOWERS

**Add new text as follows:**

**608.9 Shower Accessories.** Accessories shelves shall have size and locations complying with Section 608.9.

**608.9.1 Depth.** Accessory shelves shall project 3 inch (76 mm) maximum from face of wall.

**608.9.2 Quantities.** Not more than one shelf shall in installed in a compartment.

**608.9.3 Location.** Accessory shelves shall be located at a height of 22 inches (559 mm) minimum and 32 inches (813 mm) maximum above the bathtub or shower floor. The shelves shall not overlap the seat or be located under the area required for controls.

---

**REASON:** This proposal provides guidance for surface mounted shelves inside the bathing fixtures.

Committee Action: Disapproved 28-0-1

#### REPORT OF HEARING:

**Modification (if any):**

**Committee Reason:** The term ‘accessory’ is too broad. There should be consideration for both surface mounted and recessed shelves. If you do not allow a shelf under the controls, the shelf would be out of the reach of the person on the seat. Why not allow over the grab bar if it does not obstruction controls or the grab bars? Why only one shelf allowed. This does not address where someone installs dispensers for shampoo on the wall. This needs to be addressed, but needs the bathing work group to reconsider the proposal.

608.9-ANDERSON.doc

Report for 06-73– 2021		
Committee decision: D	Committee Vote at Meeting: 28-0-1	Committee Vote on Ballot:
<b>REPORT OF HEARING:</b> Modification (if any): Committee Reason: The term ‘accessory’ is too broad. There should be consideration for both surface mounted and recessed shelves. If you do not allow a shelf under the controls, the shelf would be out of the reach of the person on the seat. Why not allow over the grab bar if it does not obstruction controls or the grab bars? Why only one shelf allowed. This does not address where someone installs dispensers for shampoo on the wall. This needs to be addressed, but needs the bathing work group to reconsider the proposal.		

<b>Report for 06-73– 2021</b>		
<b>PUBLIC COMMENT- FIRST DRAFT:</b>		
Proponent:		
Desired Action:		
Modification:		
Reason:		
<i>Committee decision: AS/AM/D</i>	<i>Committee Vote at Meeting:</i>	<i>Committee Vote on Ballot:</i>
<b>REPORT OF HEARING – FIRST DRAFT</b>		
Modification (if any):		
Committee Reason:		
<b>PUBLIC COMMENT- SECOND DRAFT:</b>		
Proponent:		
Desired Action:		
Modification:		
Reason:		
<i>Committee decision: AS/AM/D</i>	<i>Committee Vote at Meeting:</i>	<i>Committee Vote on Ballot:</i>
<b>FINAL ACTION:</b>		
Modification (if any):		
Committee Reason:		

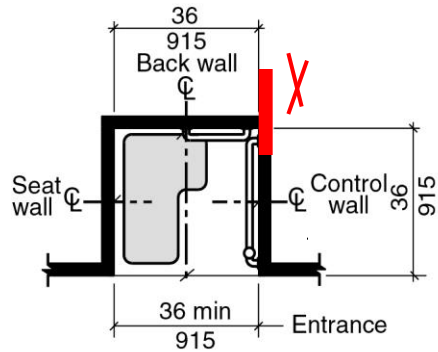
# 06-74 – 2021

Figures 608.2.1.1, 608.2.1.2(A), 608.2.1.2(B), 608.2.1.2(C), 608.3.1(B), 608.3.2(B), 608.3.3(B), 1104.11.3.1.3.3(A), 1104.11.3.1.3.3(B)

Proponent: Kimberly Paarlberg, International Code Council

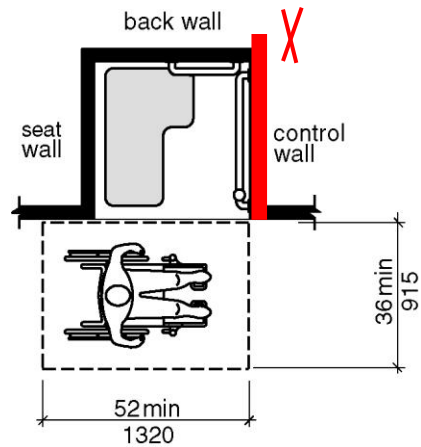
Revise as follows:

## SECTION 608 SHOWER COMPARTMENTS

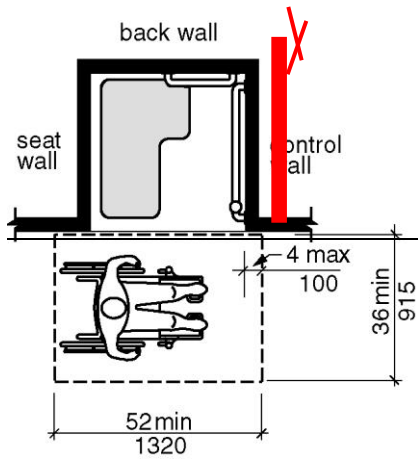


Note: inside finished dimensions measured at the center points of opposing sides

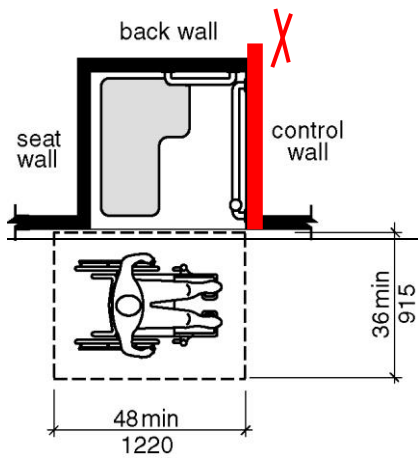
**FIGURE 608.2.1.1  
TRANSFER-TYPE SHOWER COMPARTMENT SIZE**



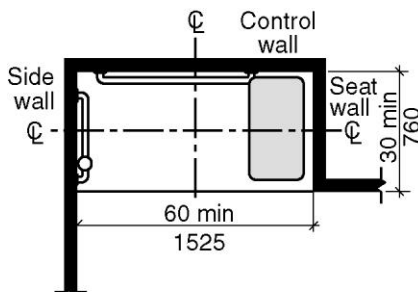
**FIGURE 608.2.1.2(A)  
TRANSFER-TYPE SHOWER COMPARTMENT CLEARANCES  
NEW BUILDINGS –OPTION 1**



**FIGURE 608.2.1.2(B)**  
**TRANSFER-TYPE SHOWER COMPARTMENT CLEARANCES**  
**NEW BUILDINGS - OPTION 2**



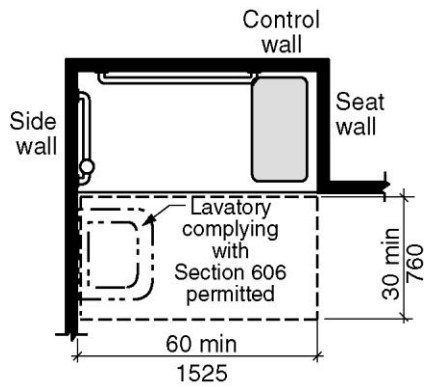
**FIGURE 608.2.1.2(C)**  
**TRANSFER-TYPE SHOWER COMPARTMENT CLEARANCES**  
**EXISTING BUILDINGS**



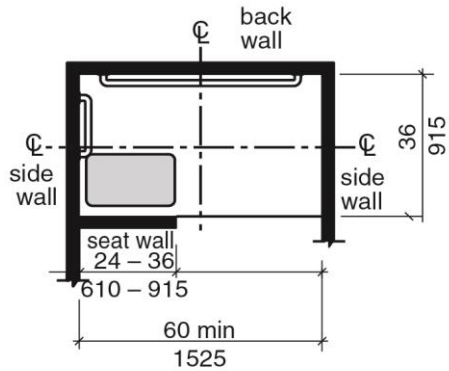
Note: inside finished dimensions measured at the center points of opposing sides

**FIGURE 608.2.2.1**  
**STANDARD ROLL-IN-TYPE SHOWER COMPARTMENT SIZE**



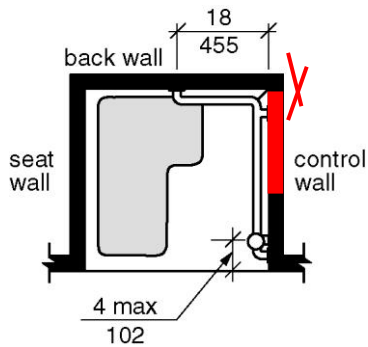


**FIGURE 608.2.2.2**  
**STANDARD ROLL-IN-TYPE SHOWER COMPARTMENT CLEARANCE**

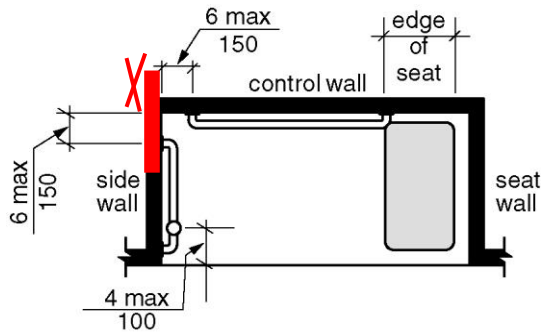


Note: inside finished dimensions measured at the center points of opposing sides

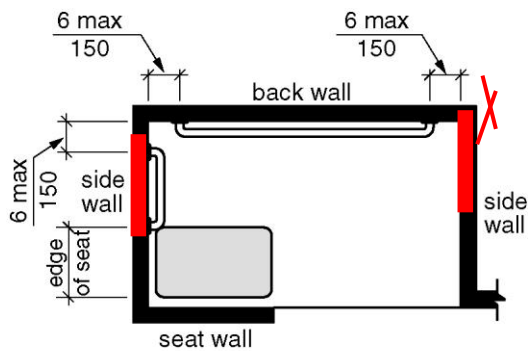
**FIGURE 608.2.3.1**  
**ALTNATE ROLL-IN-TYPE SHOWER COMPARTMENT SIZE**



**FIGURE 608.3.1(B)**  
**GRAB BARS IN TRANSFER-TYPE SHOWER-PLAN**



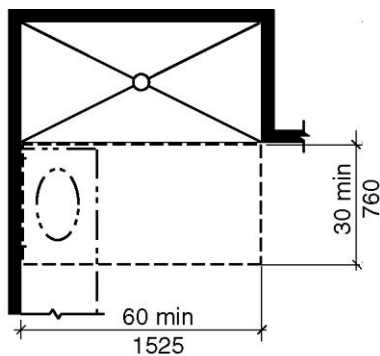
**FIGURE 608.3.2(B)**  
**GRAB BARS IN STANDARD ROLL-IN-TYPE SHOWER - PLAN**



(b)  
 Plan

**FIGURE 608.3.3(B)**  
**GRAB BARS IN ALTERNATIVE ROLL-IN-TYPE SHOWER - PLAN**

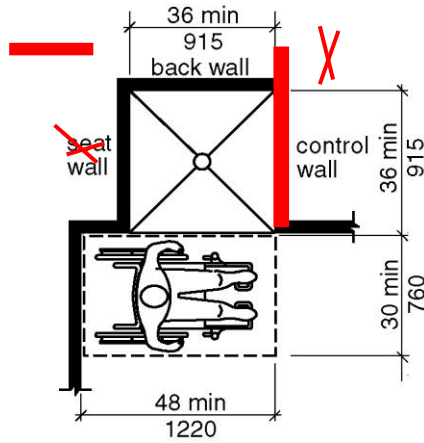
**SECTION 1103**  
**TYPE A UNITS**



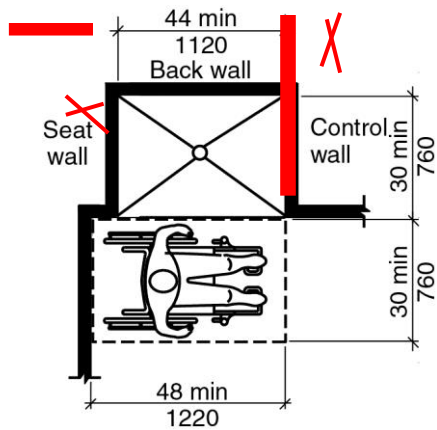
Note: Lavatory permitted per  
 Section 608.2.2

**FIGURE 1103.11.2.5.2**  
**STANDARD ROLL-IN-TYPE SHOWER COMPARTMENT**  
**TYPE A UNITS**

**SECTION 11034  
TYPE B UNITS**



**FIGURE 1104.11.3.1.3.3(A)  
TRANSFER-TYPE SHOWER COMPARTMENT IN TYPE B UNITS**



**FIGURE 1104.11.3.1.3.3(B)  
TRANSFER-TYPE SHOWER COMPARTMENT IN TYPE B UNITS EXCEPTION**

**REASON:** The current drawings for showers are not consistent and do not show the typical configuration for common plumbing walls. The current bathtub drawings are consistent for common plumbing wall and a forward approach to the clear floor space. This is a suggestion for making them match in Chapter 6 and 11. There are no changes to technical criteria.

Committee Action: Disapproved (Vote: 31-0-3)

**REPORT OF HEARING:  
Modification (if any):**

**Committee Reason:** Refer to editorial committee.

Chapter 6-PAARLBERG.doc

<b>Report for 06-74- 2021</b>		
<i>Committee decision: D</i>	<i>Committee Vote at Meeting: 31-0-3</i>	<i>Committee Vote on Ballot:</i>
<b>REPORT OF HEARING:</b>		
Modification (if any):		
Committee Reason: Refer to editorial committee.		
<b>PUBLIC COMMENT- FIRST DRAFT:</b>		
Proponent:		
Desired Action:		
Modification:		
Reason:		
<i>Committee decision: AS/AM/D</i>	<i>Committee Vote at Meeting:</i>	<i>Committee Vote on Ballot:</i>
<b>REPORT OF HEARING – FIRST DRAFT</b>		
Modification (if any):		
Committee Reason:		
<b>PUBLIC COMMENT- SECOND DRAFT:</b>		
Proponent:		
Desired Action:		
Modification:		
Reason:		
<i>Committee decision: AS/AM/D</i>	<i>Committee Vote at Meeting:</i>	<i>Committee Vote on Ballot:</i>
<b>FINAL ACTION:</b>		
Modification (if any):		
Committee Reason:		

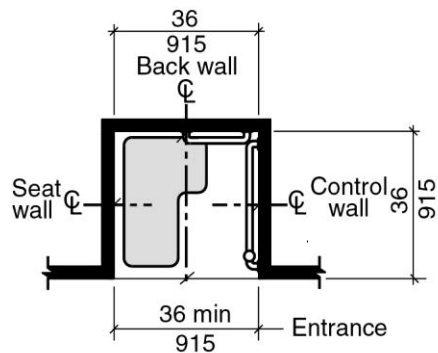
# 06-75 – 2021

Figures 608.2.1.1, 608.2.1.2(A), 608.2.1.2(B), 608.2.1.2(C), 608.3.1(B), 608.3.2(B), 608.3.3(B), 1104.11.3.1.3.3(A), 1104.11.3.1.3.3(B)

Proponent: Ed Steinfeld, IDEA Center, University of Buffalo representing RESNA

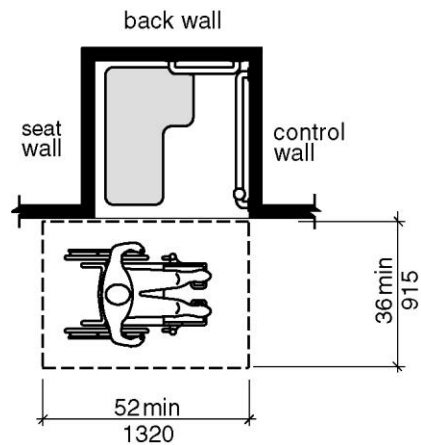
Revise as follows:

## SECTION 608 SHOWER COMPARTMENTS

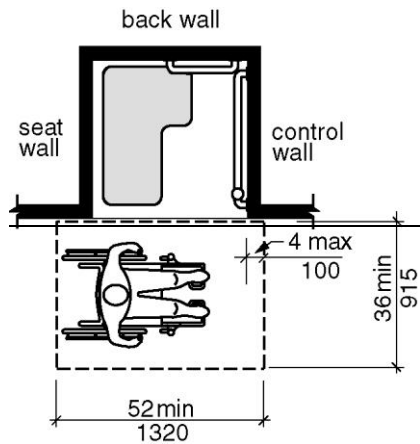


Note: inside finished dimensions measured at the center points of opposing sides

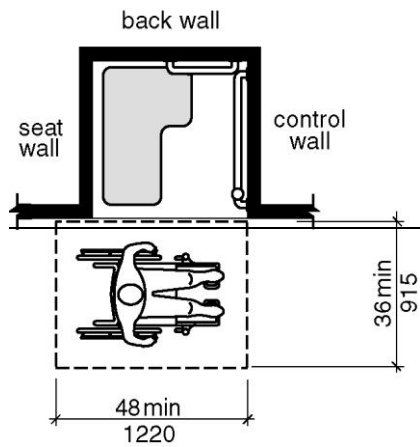
**FIGURE 608.2.1.1  
TRANSFER-TYPE SHOWER COMPARTMENT SIZE**



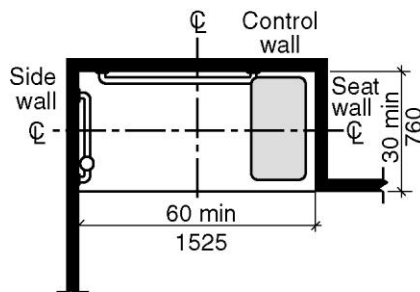
**FIGURE 608.2.1.2(A)  
TRANSFER-TYPE SHOWER COMPARTMENT CLEARANCES  
NEW BUILDINGS – OPTION 1**



**FIGURE 608.2.1.2(B)**  
**TRANSFER-TYPE SHOWER COMPARTMENT CLEARANCES**  
**NEW BUILDINGS - OPTION 2**

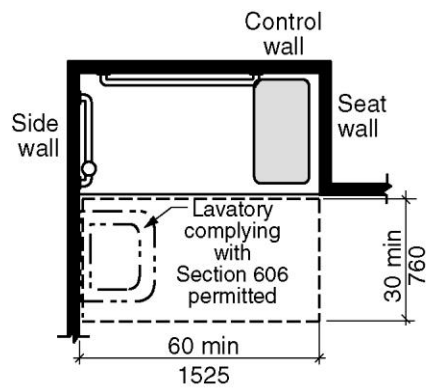


**FIGURE 608.2.1.2(C)**  
**TRANSFER-TYPE SHOWER COMPARTMENT CLEARANCES**  
**EXISTING BUILDINGS**

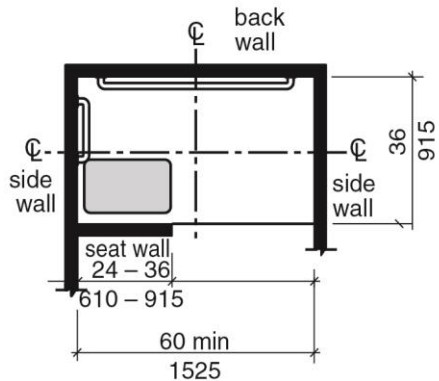


Note: inside finished dimensions measured at the center points of opposing sides

**FIGURE 608.2.2.1**  
**STANDARD ROLL-IN-TYPE SHOWER COMPARTMENT SIZE**

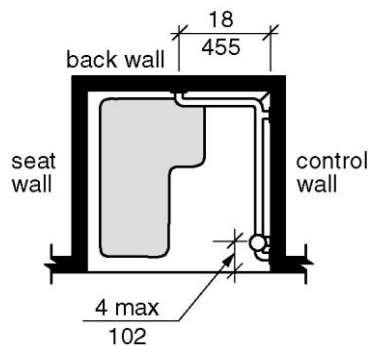


**FIGURE 608.2.2.2**  
**STANDARD ROLL-IN-TYPE SHOWER COMPARTMENT CLEARANCE**

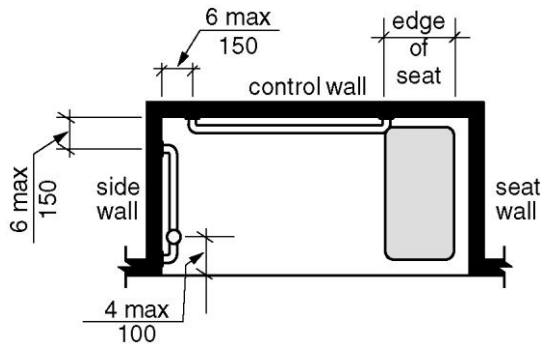


Note: inside finished dimensions measured at the center points of opposing sides

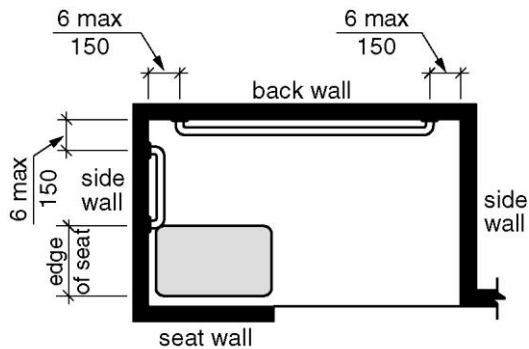
**FIGURE 608.2.3.1**  
**ALTNATE ROLL-IN-TYPE SHOWER COMPARTMENT SIZE**



**FIGURE 608.3.1(B)**  
**GRAB BARS IN TRANSFER-TYPE SHOWER-PLAN**



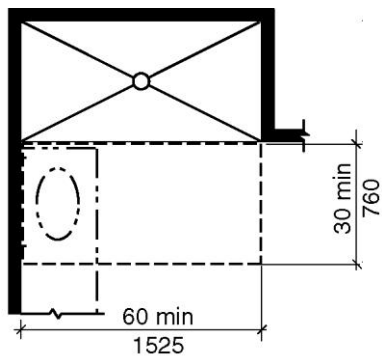
**FIGURE 608.3.2(B)**  
**GRAB BARS IN STANDARD ROLL-IN-TYPE SHOWER - PLAN**



(b)  
 Plan

**FIGURE 608.3.3(B)**  
**GRAB BARS IN ALTERNATIVE ROLL-IN-TYPE SHOWER - PLAN**

**SECTION 1103**  
**TYPE A UNITS**

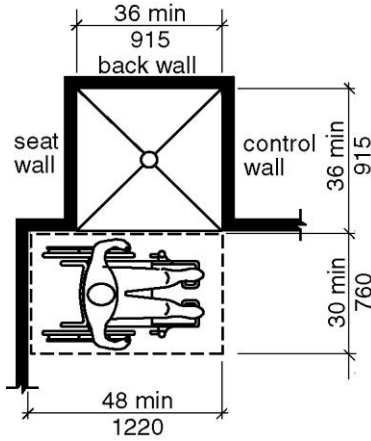


Note: Lavatory permitted per  
 Section 608.2.2

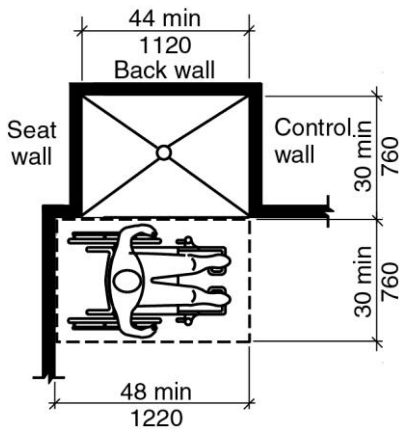
**FIGURE 1103.11.2.5.2**  
**STANDARD ROLL-IN-TYPE SHOWER COMPARTMENT**  
**TYPE A UNITS**



**SECTION 11034  
TYPE B UNITS**



**FIGURE 1104.11.3.1.3.3(A)  
TRANSFER-TYPE SHOWER COMPARTMENT IN TYPE B UNITS**



**FIGURE 1104.11.3.1.3.3(B)  
TRANSFER-TYPE SHOWER COMPARTMENT IN TYPE B UNITS EXCEPTION**

**Staff note:** The following is the proponent comment. There were no suggestions for revisions.

The depth dimensions in all figures are ambiguous. It is not clear where the depth dimension is taken...at the inside or outside of a shower curtain? What if the shower has a door?

In addition, it is not clear whether a shower stall with a door must comply with the door maneuvering clearances.

**REASON:** In public shower rooms, particularly in high end fitness centers, doors and curtains are provided for privacy. In dwelling units, some code officials measure from the center of the

curtain hanging rod, some inside of the curtain and some to the outside. Without some guidance, questions of compliance come up in the field.

Committee Action: Send to Editorial Committee

**REPORT OF HEARING:**

**Modification (if any):**

**Committee Reason:** No specific action suggested. Send to Editorial Committee for considerations related to figures.

**Chapter 6-STEINFELD.doc**

<b>Report for 06-75- 2021</b>		
<i>Committee decision: Send to editorial</i>	<i>Committee Vote at Meeting:</i>	<i>Committee Vote on Ballot:</i>
<b>REPORT OF HEARING:</b>		
Modification (if any):		
Committee Reason: No specific action suggested. Send to Editorial Committee for considerations related to figures.		
<b>PUBLIC COMMENT- FIRST DRAFT:</b>		
Proponent:		
Desired Action:		
Modification:		
Reason:		
<i>Committee decision: AS/AM/D</i>	<i>Committee Vote at Meeting:</i>	<i>Committee Vote on Ballot:</i>
<b>REPORT OF HEARING – FIRST DRAFT</b>		
Modification (if any):		
Committee Reason:		
<b>PUBLIC COMMENT- SECOND DRAFT:</b>		
Proponent:		
Desired Action:		
Modification:		
Reason:		
<i>Committee decision: AS/AM/D</i>	<i>Committee Vote at Meeting:</i>	<i>Committee Vote on Ballot:</i>
<b>FINAL ACTION:</b>		
Modification (if any):		
Committee Reason:		

## **06-76 – 2021**

**609 (New), 609.1(New), 609.2(New), 609.3(New), 609.4(New), 1009.7(New)**

**Proponent:** Kimberly Paarlberg, International Code Council

**Add new text as follows:**

### **SECTION 609** **POOLSIDE OR OUTDOOR RINSING SHOWERS**

**609.1 Poolside or outdoor rinsing showers.** Where poolside or outdoor rinsing showers are provided, at least one shall comply with Section 609.2 thru 609.4.

**609.2 Clear floor space.** A circular turning space complying with Section 304.3.1 shall be provided at the shower heads. The turning space shall be located so that the shower pedestal or wall with the shower head are at the one end of the space and centered on the shower head.

**609.3 Hand showers.** Provide at least one a hand-held shower spray unit with a hose 59 inches (1500 mm) long minimum. The hand-held shower spray unit shall have at least one fixed position located 15 inches minimum (380 mm) and 48 inches (1220 mm) maximum above the ground.

**EXCEPTION:** A fixed shower head located at 48 inches (1220 mm) maximum above the floor shall be permitted in place of a hand-held shower spray unit.

**609.4 Controls.** Controls for the water flow shall meet operable parts requirements in accordance with Section 309.

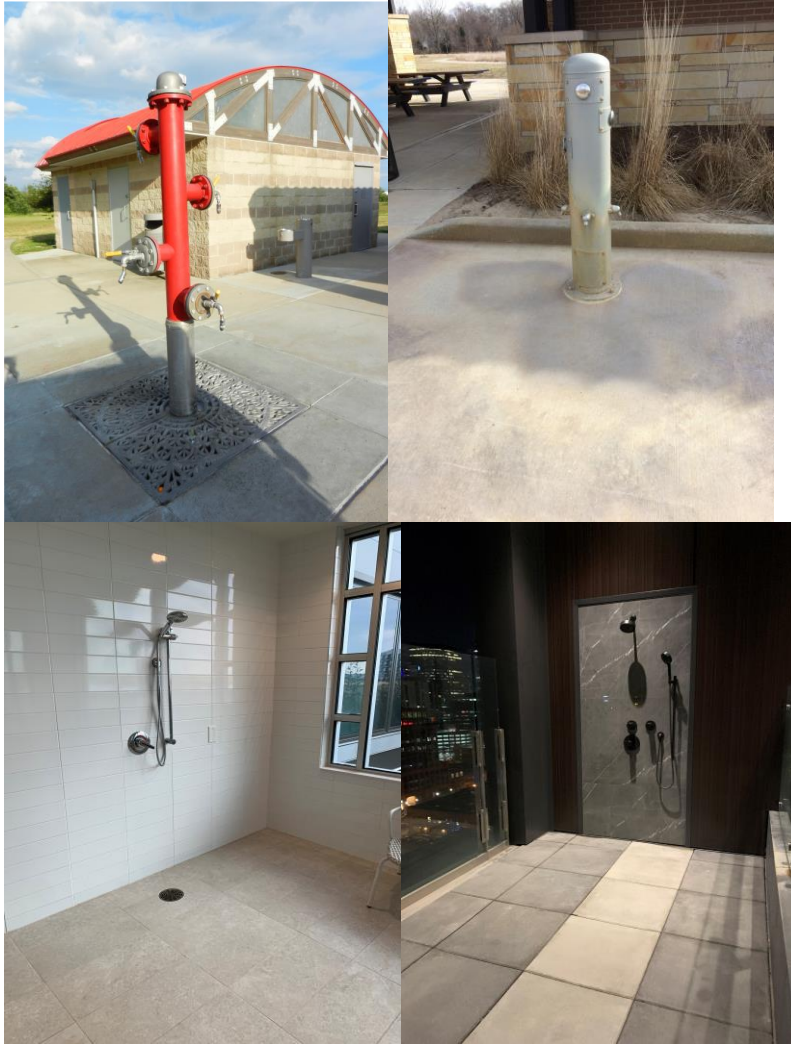
### **SECTION 1009** **SWIMMING POOLS, WADING POOLS, HOT TUBS AND SPAS**

**1009.7 Rising showers.** Where rinsing showers are provided, at least one shall comply with Section 609.

---

**REASON:** Poolside or outdoor rinsing showers are provided at swimming pools, playground splash pads and at bathrooms near beaches. There has been the question if these have to meet the general shower provisions in Section 608. Since this is not a transfer situation, seats and grab bars are should not be required. This is consistent with the Architectural Barriers Act Accessibility Standards (ABAAS) in Section 1011.7 and Table 1011.2.1.

Below are examples I found at a splash park, next to an indoor pool and next to an outdoor roof pool.



From the Access Board web site.

<https://www.access-board.gov/ada/guides/chapter-6-bathing-rooms/>

Are rinsing showers at swimming pools, beaches, and camping areas required to comply as showers?

Shower fixtures located outside bathrooms for use at swimming pools and beaches are not required to comply as showers. However, they must still meet applicable requirements for operable parts, including clear floor space and compliant controls within accessible reach range. The ABA Standards, which apply to federally funded facilities, include provisions for outdoor developed areas on federal lands. These provisions include requirements for outdoor rinsing showers (§1011.7) which can be consulted as a reference for other types of outdoor sites.

Committee Action: As Modified 24-5-2  
modification to remove scoping 18-6-2;  
modification to remove circular and allow all turning 19-5-4

## REPORT OF HEARING:

### Modification (if any):

### Further revise as follows:

#### SECTION 609 ~~POOLSIDE OR OUTDOOR~~ RINSING SHOWERS

**609.1 ~~Poolside or outdoor~~ rinsing showers.** ~~Where poolside or outdoor~~ rinsing showers ~~are provided, at least one~~ shall comply with Section 609.2 thru 609.4.

**609.2 Clear floor space.** A ~~circle~~ turning space complying with Section 304.3.1 shall be provided at the shower heads. The turning space shall be located so that the shower pedestal or wall with the shower head are at the one end of the space and centered on the shower head.

**609.3 Hand showers.** ~~Provide at least one~~ A hand-held shower spray unit with a hose 59 inches (1500 mm) long minimum shall be provided. The hand-held shower spray unit shall have at least one fixed position located 15 inches minimum (380 mm) and 48 inches (1220 mm) maximum above the ground.

**EXCEPTION:** A fixed shower head located at 48 inches (1220 mm) maximum above the floor shall be permitted in place of a hand-held shower spray unit.

**609.4 Controls.** Controls for the water flow shall meet operable parts requirements in accordance with Section 309.

#### SECTION 1009 SWIMMING POOLS, WADING POOLS, HOT TUBS AND SPAS

~~**1009.7 Rinsing showers.** Where rinsing showers are provided, at least one shall comply with Section 609.~~

**Committee Reason:** The modification to removed ‘poolside or outdoor’ and ‘at least one’ in the title, Section 609.1, 609.3 and 1009.7 was to remove the scoping in the proposal. There were concerns raised that removing ‘poolside or outdoor’ could be read to allow for this option for showers that were not intended to be address by this proposal. The modification to Section 609.2 was to allow either a circular or T-turn at the hand shower – however, there may be additional revisions to the 2<sup>nd</sup> sentence needed to coordinate properly with T-turns. This proposal is consistent with the recommendations for the U.S. Access Board for these types of showers. This will clarify that a rinsing shower does not always have to have a seat and grab bars like a shower for bathing; and will provide appropriate criteria. The committee recommended that this be located at the end of Chapter 6 with the Saunas rather than following the shower section.

**Staff note:** The following revisions would be required to Section 609.3 for consistency with the provisions for hand showers approved by the committee in 06-45 and 06-47.

**Further revise as follows:**

**609.3 Hand showers.** A hand-held shower ~~spray unit~~ with a hose 59 inches (1500 mm) ~~long~~ minimum in length shall be provided. ~~The hand-held shower spray unit shall have at least one fixed position located 15 inches minimum (380 mm) and 48 inches (1220 mm) maximum above the ground.~~ A mount to hold the hand shower shall be located at a height of 38 inches (965 mm) minimum and 48 inches (1220 mm) maximum above the floor. A fixed shower head, in addition to the hand shower shall be permitted.

**EXCEPTIONS:**

1. A fixed shower head located at 48 inches (1220 mm) maximum above the floor shall be permitted in place lieu of a hand-held shower ~~spray unit~~.
2. The mount to hold the hand shower shall be permitted to be located on a vertical bar provided that the mount is adjustable in height and can be located within the area specified for the fixed mount.

**609 NEW-PAARLBERG.doc**

Report for 06-76- 2021		
Committee decision: AM	Committee Vote at Meeting: 24-5-2	Committee Vote on Ballot:
<p><b>REPORT OF HEARING:</b> Modification (if any): <b>Further revise as follows:</b></p>		
<p><b>SECTION 609</b> <b>POOLSIDE OR OUTDOOR RINSING SHOWERS</b></p>		
<p><b>609.1 Poolside or outdoor rinsing showers.</b> <del>Where poolside or outdoor rinsing showers are provided, at least one</del> shall comply with Section 609.2 thru 609.4.</p>		
<p><b>609.2 Clear floor space.</b> A <del>circular</del> turning space complying with Section 304.3-4 shall be provided at the shower heads. The turning space shall be located so that the shower pedestal or wall with the shower head are at the one end of the space and centered on the shower head.</p>		
<p><b>609.3 Hand showers.</b> <del>Provide at least one</del> A hand-held shower spray unit with a hose 59 inches (1500 mm) long minimum <u>shall be provided</u>. The hand-held shower spray unit shall have at least one fixed position located 15 inches minimum (380 mm) and 48 inches (1220 mm) maximum above the ground. <b>EXCEPTION:</b> A fixed shower head located at 48 inches (1220 mm) maximum above the floor shall be permitted in place of a hand-held shower spray unit.</p>		
<p><b>609.4 Controls.</b> Controls for the water flow shall meet operable parts requirements in accordance with Section 309.</p>		
<p><b>SECTION 1009</b> <b>SWIMMING POOLS, WADING POOLS, HOT TUBS AND SPAS</b></p>		
<p><del>1009.7 Rinsing showers. Where rinsing showers are provided, at least one shall comply with Section 609.</del></p>		
<p>Committee Reason: The modification to removed 'poolside or outdoor' and 'at least one' in the title, Section 609.1, 609.3 and 1009.7 was to remove the scoping in the proposal. There were concerns raised that removing 'poolside or outdoor' could be read to allow for this option for showers that were not intended to be address by this proposal. The modification to Section 609.2 was to allow either a circular or T-turn at the hand shower – however, there may be additional revisions to the 2<sup>nd</sup> sentence needed to coordinate properly with T-turns. This proposal is consistent with the recommendations for the U.S. Access Board for these types of showers. This will clarify that a rinsing shower does not always have to have a seat and grab bars like a shower for bathing; and will provide appropriate criteria. The committee recommended that this be located at the end of Chapter 6 with the Saunas rather than following the shower section.</p>		
<p><b>Staff note:</b> The following revisions would be required to Section 609.3 for consistency with the provisions for hand showers approved by the committee in 06-45 and 06-47.</p>		
<p><b>Further revise as follows:</b></p>		
<p><b>609.3 Hand showers.</b> A hand-held shower <del>spray unit</del> with a hose 59 inches (1500 mm) <del>long</del> minimum <u>in length</u> shall be provided. <del>The hand-held shower spray unit shall have at least one fixed position located 15 inches minimum (380 mm) and 48 inches (1220 mm) maximum above the ground.</del></p>		

**Report for 06-76– 2021**

A mount to hold the hand shower shall be located at a height of 38 inches (965 mm) minimum and 48 inches (1220 mm) maximum above the floor. A fixed shower head, in addition to the hand shower shall be permitted.

**EXCEPTIONS:**

1. A fixed shower head located at 48 inches (1220 mm) maximum above the floor shall be permitted in place lieu of a hand-held shower spray unit.
2. The mount to hold the hand shower shall be permitted to be located on a vertical bar provided that the mount is adjustable in height and can be located within the area specified for the fixed mount.

**PUBLIC COMMENT- FIRST DRAFT:**

Proponent:

Desired Action:

Modification:

Reason:

**Committee decision: AS/AM/D****Committee Vote at Meeting:****Committee Vote on Ballot:****REPORT OF HEARING – FIRST DRAFT**

Modification (if any):

Committee Reason:

**PUBLIC COMMENT- SECOND DRAFT:**

Proponent:

Desired Action:

Modification:

Reason:

**Committee decision: AS/AM/D****Committee Vote at Meeting:****Committee Vote on Ballot:****FINAL ACTION:**

Modification (if any):

Committee Reason:

# 06-77 – 2021

## 609.3

**Proponent:** Kyle Thompson, Plumbing Manufacturers International (PMI)

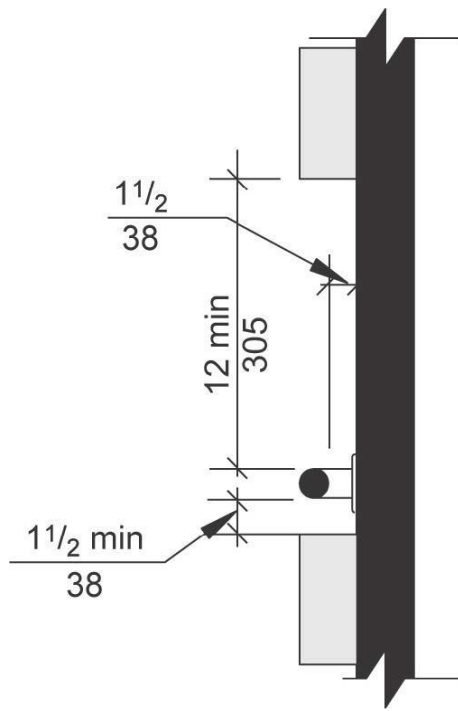
**Revise as follows:**

### SECTION 609 GRAB BARS

**609.3 Spacing.** The space between the wall and the grab bar shall be 1 1/2 inches (38 mm). The space between the grab bar and projecting objects below and at the ends of the grab bar shall be 1 1/2 inches (38 mm) minimum. The space between the grab bar and projecting objects above the grab bar shall be 12 inches (305 mm) minimum.

#### **Exceptions:**

1. The space between the grab bars and shower controls, shower fittings, and other grab bars above the grab bar shall be permitted to be 1 1/2 inches (38 mm) minimum.
2. Recessed dispensers projecting from the wall 1/4 inch (6.4 mm) maximum measured from the face of the dispenser and complying with Section 604.7 shall be permitted within the 12-inch (305 mm) space above and the 1 1/2-inch (38 mm) spaces below and at the ends of the grab bar.
3. Flushing device cover plates and their controls projecting from the wall up to 1 inch (25 mm) maximum shall be permitted to be 1-1/2 inch (38 mm) minimum above the grab bar.





**FIGURE 609.3  
SPACING OF GRAB BARS**

---

**REASON:** Adding exception 3 is consistent with other exceptions already identified in this section and the protrusion is limited to no greater than 1” which will not interfere with the continued use of the rear grab bar. This proposed change would make it easier on the user to access a flushing device cover plate and its controls located above the grab bar while still ensuring a minimum 1-1/2 inch space between the plate/controls and the grab bar and a limitation on the maximum projection beyond the wall. Such accommodations have already been provided in the standard for shower controls and dispensers.

The following figures are examples of the flushing device cover plates and their controls. The engineering for in-wall tank type toilets requires the flush plate remain within a specific vertical range from the bowl and its location can also be restricted horizontally. For flushometer type toilets, the rough plumbing may restrict the location. Additionally, if a grab bar is set at 36” and the flush plate must be 12” above that, the flush plate is pushed out of the obstructed side reach range of 48”, limiting the options for the end-user.



Committee Action: As Modified 24-2-1  
Modification to add ‘and pushbutton’ 17-8-3;  
Modification to add ‘automatic’ 21-6-1;

Modification to change dimension above to 4" 22-4-1

**REPORT OF HEARING:**

**Modification (if any):**

**Further revise as follows:**

**SECTION 609  
GRAB BARS**

**609.3 Spacing.** The space between the wall and the grab bar shall be 1 1/2 inches (38 mm). The space between the grab bar and projecting objects below and at the ends of the grab bar shall be 1 1/2 inches (38 mm) minimum. The space between the grab bar and projecting objects above the grab bar shall be 12 inches (305 mm) minimum.

**Exceptions:**

1. The space between the grab bars and shower controls, shower fittings, and other grab bars above the grab bar shall be permitted to be 1 1/2 inches (38 mm) minimum.
2. Recessed dispensers projecting from the wall 1/4 inch (6.4 mm) maximum measured from the face of the dispenser and complying with Section 604.7 shall be permitted within the 12-inch (305 mm) space above and the 1 1/2-inch (38 mm) spaces below and at the ends of the grab bar.
3. Automatic and push button Flushing device cover plates and ~~their~~ controls projecting from the wall up to 1 inch (25 mm) maximum shall be permitted to be ~~1-1/2~~ 4 inch (~~38~~ 100 mm) minimum above the grab bar.

**Committee Reason:** The modifications to add ‘automatic and push button’ were to clarify what type of flushing device this is meant to address (i.e., not on handle on the tank). The modification to increase the clearance above the grab bar from 1-1/2” to 4” was to address concerns about this plate blocking access to the rear grab bar, but would still allow for the control to be within reach range of someone sitting in the transfer location. The new exception is needed to address access to these devices. The committee approved centerline controls in 06-20. These devices are required to be centered on the back wall to function with the plumbing flushing system.

**609.3-THOMPSON.doc**

<b>Report for 06-77- 2021</b>		
<i>Committee decision: AM</i>	<i>Committee Vote at Meeting: 24-2-1</i>	<i>Committee Vote on Ballot:</i>
<b>REPORT OF HEARING:</b> Modification (if any): Further revise as follows:  <p style="text-align: center;"><b>SECTION 609</b> <b>GRAB BARS</b></p> <b>609.3 Spacing.</b> The space between the wall and the grab bar shall be 1 1/2 inches (38 mm). The space between the grab bar and projecting objects below and at the ends of the grab bar shall be 1 1/2 inches (38 mm) minimum. The space between the grab bar and projecting objects above the		

**Report for 06-77– 2021**

grab bar shall be 12 inches (305 mm) minimum.

**Exceptions:**

1. The space between the grab bars and shower controls, shower fittings, and other grab bars above the grab bar shall be permitted to be 1 1/2 inches (38 mm) minimum.
2. Recessed dispensers projecting from the wall 1/4 inch (6.4 mm) maximum measured from the face of the dispenser and complying with Section 604.7 shall be permitted within the 12-inch (305 mm) space above and the 1 1/2-inch (38 mm) spaces below and at the ends of the grab bar.
3. Automatic and push button Flushing device cover plates and ~~their~~ controls projecting from the wall up to 1 inch (25 mm) maximum shall be permitted to be ~~4-1/2~~ 4 inch (~~38~~ 100 mm) minimum above the grab bar.

Committee Reason: The modifications to add 'automatic and push button' were to clarify what type of flushing device this is meant to address (i.e., not on handle on the tank). The modification to increase the clearance above the grab bar from 1-1/2" to 4" was to address concerns about this plate blocking access to the rear grab bar, but would still allow for the control to be within reach range of someone sitting in the transfer location. The new exception is needed to address access to these devices. The committee approved centerline controls in 06-20. These devices are required to be centered on the back wall to function with the plumbing flushing system.

**PUBLIC COMMENT- FIRST DRAFT:**

Proponent:

Desired Action:

Modification:

Reason:

**Committee decision: AS/AM/D**

**Committee Vote at Meeting:**

**Committee Vote on Ballot:**

**REPORT OF HEARING – FIRST DRAFT**

Modification (if any):

Committee Reason:

**PUBLIC COMMENT- SECOND DRAFT:**

Proponent:

Desired Action:

Modification:

Reason:

**Committee decision: AS/AM/D**

**Committee Vote at Meeting:**

**Committee Vote on Ballot:**

**FINAL ACTION:**

Modification (if any):

Committee Reason:

## 06-78 – 2021

### 609.4, 609.4.1, 609.4.2

**Proponent:** Marsha Mazz, United Spinal Association

**Revise as follows:**

#### SECTION 609 GRAB BARS

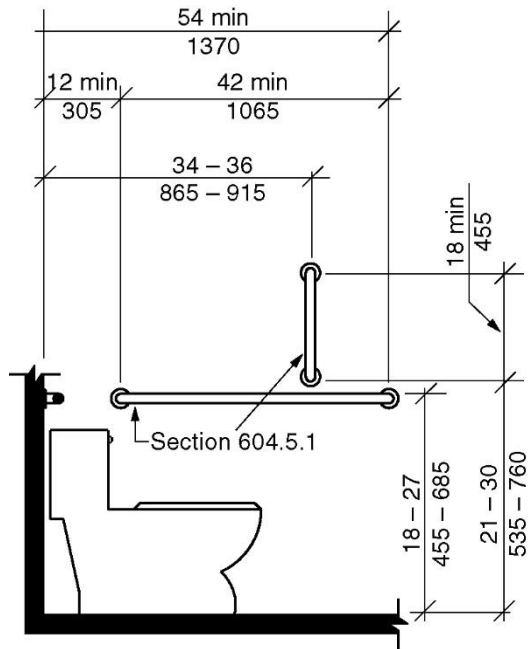
**609.4 Position of grab bars.** Grab bars shall be positioned in accordance with Section 609.4.1, 609.4.2, or 609.4.3 as applicable.

**609.4.1 General Horizontal position.** Except for the lower grab bar on the back wall of a bath tub, ~~grab bars shall required to be installed in a horizontal position shall be~~ 33 inches (840 mm) minimum and 36 inches (915 mm) maximum above the floor measured to the top of the gripping surface ~~or shall be installed as required by Items 1 through 3.~~

- ~~1. The lower grab bar on the back wall of a bathtub shall comply with Section 607.4.1.1 or 607.4.2.1.~~
- ~~2. Vertical grab bars shall comply with Sections 604.5.1.2, 607.4.1.2.2, 607.4.2.2 and 608.3.1.2.~~
- ~~3. Grab bars at water closets primarily for children's use shall comply with Section 609.4.2.~~

**609.4.2 Vertical position.** The distance between grab bars required to be installed in a vertical position and any object shall be measured from the object to the centerline of the bar. Vertical grab bars shall comply with Sections 604.5.1.2, 607.4.1.2.2, 607.4.2.2 and 608.3.1.2 as applicable.

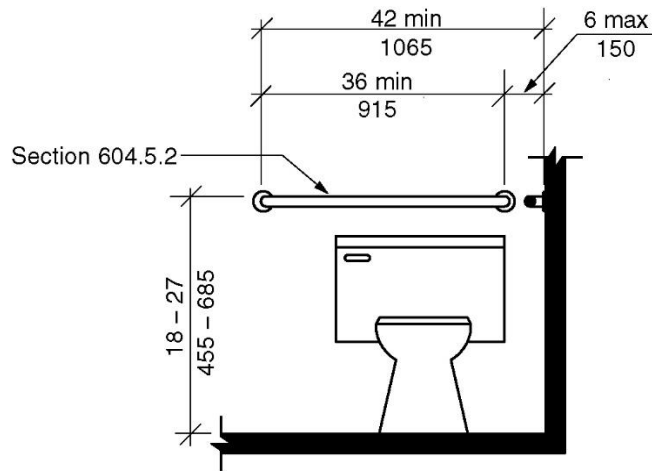
~~609.4.2~~ **609.4.3 Position of children's grab bars.** At water closets primarily for children's use complying with Section 604.11, grab bars ~~shall required to be installed in a horizontal position shall be~~ 18 inches (455 mm) minimum and 27 inches (685 mm) maximum above the floor measured to the top of the gripping surface. A vertical grab bar shall be mounted with the bottom of the bar located ~~between~~ 21 inches (535 mm) minimum and 30 inches (760 mm) maximum above the floor and with the centerline of the bar located ~~between~~ 34 inches (865 mm) minimum and 36 inches (915 mm) maximum from the rear wall.



Note: For adult dimensions see Fig. 604.5.1

(a) Side Wall View

**FIGURE 609.4.2(A)-609.4.3(A)**  
**POSITIONS OF CHILDREN'S GRAB BARS**  
**SIDE-WALL VIEW**



Note: For adult dimensions see Fig. 604.5.2

(b) Rear Wall View

**FIGURE 609.4.2(B)-609.4.3(B)**  
**POSITIONS OF CHILDREN'S GRAB BARS**  
**REAR-WALL VIEW**

**REASON:** This proposal simplifies a very confusing section. As written, the first part of the sentence in Section 609.4 requires grab bars to be installed in a horizontal position but, then goes on to allow options to install grab bars in a vertical position (Item #2) or in accordance with the

children’s requirements for horizontal grab bars in Section 604.11 and establishes a requirement for a vertical grab bar that is not included in Section 604.11 (Item #3). Item #1 specifically addresses the lower horizontal grab bar in a bath tub. Requirements in the base paragraph and the list are NOT interchangeable. Instead, each requirement establishes differing criteria for grab bar height or location from the back wall and the measurement method depending on its position (horizontal or vertical) or whether it is located in a bath tub.

In renumbered Section 609.4.3, the proposed revision makes clear that Section 604.11 “requires” grab bars to be installed in a horizontal position. The revision then ensures that the grab bars “shall be” installed at the specified height. We also propose to remove the word “between” in two places specifying the grab bar height and distance from the rear wall because, as written the requirement would not allow the bars to be installed at the end points of the ranges – only “between” the end points.

**NOTE:** This is a companion proposal to our proposal to revise Section 607.4. (06-41)

Committee Action: D 27-0-2

**REPORT OF HEARING:**

**Modification (if any):**

**Committee Reason:** Disapprove based on action to 06-80. The replacement proposal combines and addresses all the measurements for grab bars.

609.4.1-MAZZ.doc

<b>Report for 06-78– 2021</b>		
<i>Committee decision: D</i>	<i>Committee Vote at Meeting: 27-0-2</i>	<i>Committee Vote on Ballot:</i>
<b>REPORT OF HEARING:</b>		
Modification (if any):		
Committee Reason: Disapprove based on action to 06-80. The replacement proposal combines and addresses all the measurements for grab bars.		
<b>PUBLIC COMMENT- FIRST DRAFT:</b>		
Proponent:		
Desired Action:		
Modification:		
Reason:		
<i>Committee decision: AS/AM/D</i>	<i>Committee Vote at Meeting:</i>	<i>Committee Vote on Ballot:</i>
<b>REPORT OF HEARING – FIRST DRAFT</b>		
Modification (if any):		
Committee Reason:		
<b>PUBLIC COMMENT- SECOND DRAFT:</b>		
Proponent:		
Desired Action:		
Modification:		
Reason:		
<i>Committee decision: AS/AM/D</i>	<i>Committee Vote at Meeting:</i>	<i>Committee Vote on Ballot:</i>
<b>FINAL ACTION:</b>		
Modification (if any):		
Committee Reason:		

# 06-79 – 2021

## 609.4.1

**Proponent:** Gene Boecker, Code Consultants, Inc.

**Revise as follows:**

### SECTION 609 GRAB BARS

#### 609.4 Position of grab bars.

**609.4.1 General.** Grab bars shall be installed in a horizontal position, 33 inches (840 mm) minimum and 36 inches (915 mm) maximum above the floor measured to the top of the gripping surface or shall be installed as required by Items 1 through ~~3~~4.

1. The lower grab bar on the back wall of a bathtub shall comply with Section 607.4.1.1 or 607.4.2.1.
2. Vertical grab bars shall comply with Sections 604.5.1.2, 607.4.1.2.2, 607.4.2.2 and 608.3.1.2.
3. Grab bars at water closets primarily for children's use shall comply with Section 609.4.2.
4. Multiple grab bars on adjacent walls shall be positioned within 1/2 inch (12.7 mm) of one another in height.

---

**REASON:** There is currently nothing that requires adjacent grab bars to be consistently positioned for height. Having one grab bar at a height three inches different than an adjacent one can be a safety concern. If someone is anticipating adjacent handrails to be the same height and it is "missing" that can lead to a dangerous situation. Although the adjacent grab bars are usually near the same height, we have seen handrails three inches off due to the need for clearance over the water closet tank – the side grab bar at 33 inches while the rear grab bar was at 36 inches.

The 1/2 inch dimension is to allow slight variations in the installation and the manner in which the height might be measured.

Committee Action: D 29-0-4

#### **REPORT OF HEARING:**

#### **Modification (if any):**

**Committee Reason:** This proposal was disapproved. The same height for adjacent multiple bars on adjacent walls is addressed for showers in Section 608.3. This is justified since people move around the corner from one bar to another. The proposed text would be an issue for as written

for bathtubs with two back wall grab bars; and the height for the grab bar on the head wall would need to be flexible to not conflict with controls. At water closets this could be an issue for balancing access to toilet paper on the side wall and access into the water closet tank for repairs on the back wall. There is not technical justification for the ½” limitation.

**609.4.1-BOECKER.doc**

<b>Report for 06-79– 2021</b>		
<i>Committee decision: D</i>	<i>Committee Vote at Meeting: 29-0-4</i>	<i>Committee Vote on Ballot:</i>
<b>REPORT OF HEARING:</b>		
Modification (if any):		
Committee Reason: This proposal was disapproved. The same height for adjacent multiple bars on adjacent walls is addressed for showers in Section 608.3. This is justified since people move around the corner from one bar to another. The proposed text would be an issue for as written for bathtubs with two back wall grab bars; and the height for the grab bar on the head wall would need to be flexible to not conflict with controls. At water closets this could be an issue for balancing access to toilet paper on the side wall and access into the water closet tank for repairs on the back wall. There is not technical justification for the ½" limitation.		
<b>PUBLIC COMMENT- FIRST DRAFT:</b>		
Proponent:		
Desired Action:		
Modification:		
Reason:		
<i>Committee decision: AS/AM/D</i>	<i>Committee Vote at Meeting:</i>	<i>Committee Vote on Ballot:</i>
<b>REPORT OF HEARING – FIRST DRAFT</b>		
Modification (if any):		
Committee Reason:		
<b>PUBLIC COMMENT- SECOND DRAFT:</b>		
Proponent:		
Desired Action:		
Modification:		
Reason:		
<i>Committee decision: AS/AM/D</i>	<i>Committee Vote at Meeting:</i>	<i>Committee Vote on Ballot:</i>
<b>FINAL ACTION:</b>		
Modification (if any):		
Committee Reason:		



## 06-80 – 2021

### 609.7.1(New)

**Proponent:** Kimberly Paarlberg, International Code Council

**Add new text as follows:**

#### SECTION 609 GRAB BARS

**609.7 Installation and configuration.** Grab bars shall be installed in any manner that provides a gripping surface at the locations specified in this standard and does not obstruct the clear floor space. Horizontal and vertical grab bars shall be permitted to be separate bars, a single piece bar, or combination thereof.

**609.7.1 Length of grab bar.** The required length of a horizontal grab bar shall be measured horizontally to the center of the return or support. The required length of a vertical grab bar shall be measured vertically to the center of the return or support.

**Exception:** Where the grab bar is not supported at the ends, the required length of the grab bar shall be measured to the end of the grab bar.

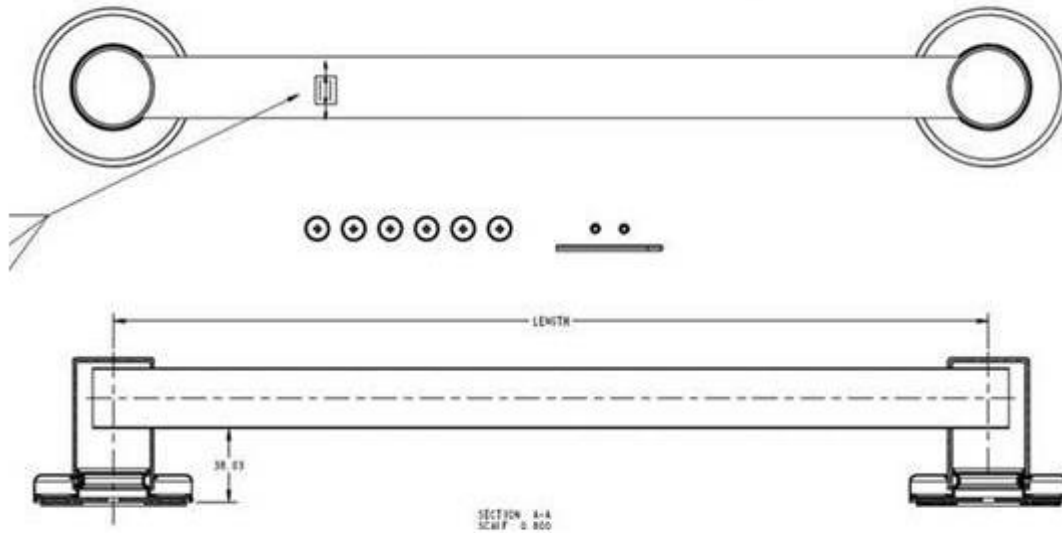
---

**REASON:** As currently written the standard does not provide specific guidance as to whether the length of a grab bar is only the straight/graspable portion of the bar or how to measure if (a) the bar is curved to return to the wall or (b) supported by a bracket that covers a portion of the bar. See the attached figures (1 and 2) for examples.

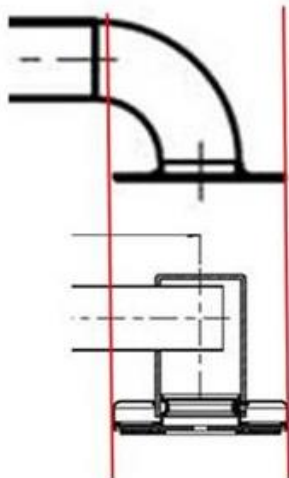
At this point it appears that while the A117.1 and ADA do not clearly address this issue, that it has been addressed by the Fair Housing Design Manual (see Figure 3 attached) and that the conventional industry practice is to measure the grab bar length to the centerline of the return (for both curved or post-mounted). Therefore, the intent of this proposal is to simply provide some clarity and language within the standard so that the provision is enforced in a consistent manner. Leaving this topic unaddressed within the standard simply leads to inconsistent application and confusion.

The language selected here for adding was based on a proposal that has also been submitted to Section 505.10 to address handrails.

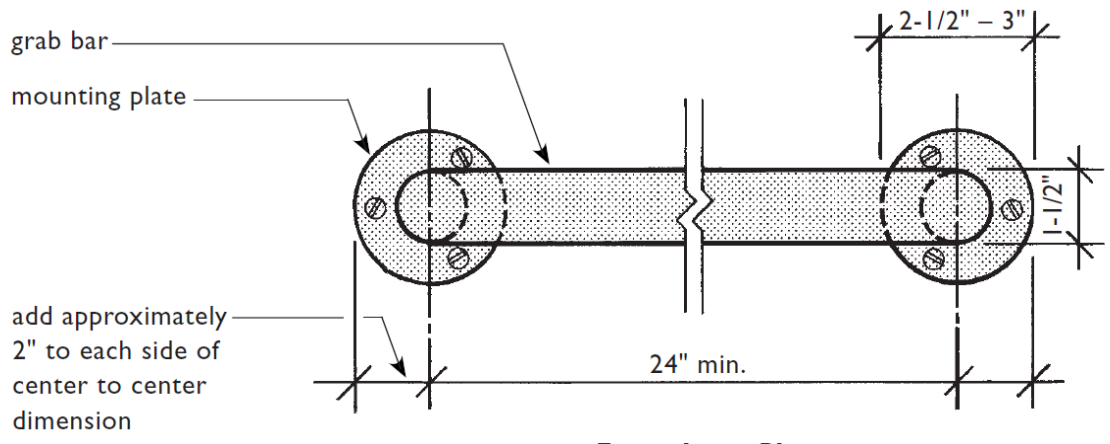
**Figure 1: (Post supported, elevation and section)**



**Figure 2: (End conditions; curved and post supported)**



**Figure 3: (Graphic from page 6.4 of Fair Housing Design Manual)**



**Escutcheon Plates  
Extend Beyond the Given Grab Bar Length**

This is an example of the type of grab bar addressed in the exception.



**Modification:**

**Replace with the following:**

**Water closets**

**604.5 Grab bars.** Grab bars for water closets shall comply with Section 609 and shall be provided in accordance with Sections 604.5.1 and 604.5.2. Grab bars shall be provided on the rear wall and on the side wall closest to the water closet.

**Exceptions:**

1. Grab bars shall not be required to be installed in a toilet room for a single occupant, accessed only through a private office and not for common use or public use, provided reinforcement has been installed in walls and located so as to permit the installation of grab bars complying with Section 604.5.
2. In detention or correction facilities, grab bars shall not be required to be installed in housing or holding cells or rooms that are specially designed without protrusions for purposes of suicide prevention.

**604.5.1 Fixed side-wall grab bars.** Fixed side-wall grab bars shall include a horizontal bar complying with Section 604.5.1.1 and a vertical grab bar complying with Section 604.5.1.2. The vertical grab bar at water closets primarily for children's use shall comply with Section 609.4.2.

**Figure 604.5.1**

**SIDE-WALL GRAB BAR FOR WATER CLOSET**

**604.5.1.1 Horizontal grab bar.** A horizontal grab bar 42 inches (1065 mm) minimum in length shall be located 12 inches (305 mm) maximum from the rear wall and extend 54 inches (1370 mm) minimum from the rear wall.

**604.5.1.2 Vertical grab bar.** A vertical grab bar 18 inches (455 mm) minimum in length shall be mounted with the bottom of the bar located 39 inches (990 mm) minimum and 41 inches (1040 mm) maximum above the floor, and ~~with the center line of the bar~~ located 39 inches (990 mm) minimum and 41 inches (1040 mm) maximum from the rear wall.

**604.5.2 Rear-wall grab bars.** The fixed rear-wall grab bar shall

1. Be 36 inches (915 mm) minimum in length,
2. Be located 6 inches maximum (150 mm) from the side wall, and
3. Extend 42 inches (1065 mm) minimum from the side wall.

**Exceptions:**

1. The rear grab bar shall be permitted to be 24 inches (610 mm) minimum in length, centered on the water closet, where wall space does not permit a grab bar 36 inches (915 mm) minimum in length due to the location of a recessed fixture adjacent to the water closet.

2. Where an administrative authority requires flush controls for flush valves to be located in a position that conflicts with the location of the rear grab bar, that grab bar shall be permitted to be split or shifted to the open side of the toilet area.

## **Bathtubs**

**607.4 Grab bars.** Grab bars shall comply with Section 609 and shall be provided in accordance with Section 607.4.1 or 607.4.2.

**Exception:** Grab bars shall not be required to be installed in a bathing facility for a single occupant accessed only through a private office and not for common use or public use, provided reinforcement has been installed in walls and located so as to permit the installation of grab bars complying with Section 607.4.

### **Bathtubs with permanent seats**

**607.4.1 Bathtubs with permanent seats.** For bathtubs with permanent seats, grab bars complying with Section 607.4.1 shall be provided.

#### **Figure 607.4.1 (A)**

GRAB BARS FOR BATHTUBS WITH SEAT AT HEAD END OF TUB – ELEVATION

#### **Figure 607.4.1 (B)**

GRAB BARS FOR BATHTUBS WITH SEAT AT HEAD END OF TUB – PLAN

**607.4.1.1 Back wall.** Two horizontal grab bars shall be provided on the back wall, one complying with Section 609.4 and the other located 8 inches (205 mm) minimum and 10 inches (255 mm) maximum above the rim of the bathtub. Each grab bar shall be located 15 inches (380 mm) maximum from the head end wall and extend to 12 inches (305 mm) maximum from the control end wall.

**607.4.1.2 Control end wall.** Control end wall grab bars shall comply with Section 607.4.1.2.

**Exception:** An L-shaped continuous grab bar of equivalent dimensions and positioning shall be permitted to serve the function of separate vertical and horizontal grab bars.

**607.4.1.2.1 Horizontal grab bar.** A horizontal grab bar 24 inches (610 mm) minimum in length shall be provided on the control end wall beginning ~~near~~ 4 inches (100 mm) maximum from the front edge of the bathtub and extending toward the inside corner of the bathtub.

**607.4.1.2.2 Vertical grab bar.** A vertical grab bar 18 inches (455 mm) minimum in length shall be provided on the control end wall 3 inches (75 mm) minimum and 6 inches (150 mm) maximum above the horizontal grab bar, and 4 inches (100 mm) maximum inward from the front edge of the bathtub.

### **Bathtubs with removeable in tub seats**

**607.4.2 Bathtubs with removable seats.** For bathtubs with removable seats, grab bars complying with Section 607.4.2 shall be provided.

**Figure 607.4.2 (A)**

**GRAB BARS FOR BATHTUBS WITH REMOVABLE SEATS – ELEVATION**

**Figure 607.4.2 (B)**

**GRAB BARS FOR BATHTUBS WITH REMOVABLE SEATS - PLAN**

**607.4.2.1 Back wall.** Two horizontal grab bars shall be provided on the back wall, one complying with Section 609.4 and the other located 8 inches (205 mm) minimum and 10 inches (255 mm) maximum above the rim of the bathtub. Each grab bar shall be 24 inches (610 mm) minimum in length, located 24 inches (610 mm) maximum from the head end wall and extend to 12 inches (305 mm) maximum from the control end wall.

**607.4.2.2 Control end wall.** Control end wall grab bars shall comply with Section 607.4.1.2.

**607.4.2.3 Head end wall.** A horizontal grab bar 12 inches (305 mm) minimum in length shall be provided on the head end wall at beginning 4 inches (100 mm) maximum from the front edge of the bathtub.

**Showers**

**608.3 Grab bars.** Grab bars shall comply with Section 609 and shall be provided in accordance with Section 608.3. Where multiple grab bars are used, required horizontal grab bars shall be installed at the same height above the floor.

**Exception:** Grab bars shall not be required to be installed in a shower for a single occupant, accessed only through a private office and not for common use or public use, provided reinforcement has been installed in walls and located so as to permit the installation of grab bars complying with Section 608.3.

**Transfer showers**

**608.3.1 Transfer-type showers.** Grab bars for transfer type showers shall comply with Section 608.3.1.

**Figure 608.3.1 (A)**

**GRAB BARS IN TRANSFER-TYPE SHOWER – ELEVATION**

**Figure 608.3.1 (B)**

**GRAB BARS IN TRANSFER-TYPE SHOWER - PLAN**

**608.3.1.1 Horizontal grab bars.** Horizontal grab bars shall be provided across the control wall beginning 4 inches (100 mm) maximum from the front edge of the shower compartment and on the back wall to a point 18 inches (455 mm) from the control wall.

**608.3.1.2 Vertical grab bar.** A vertical grab bar 18 inches (455 mm) minimum in length shall be provided on the control end wall 3 inches (75 mm) minimum and 6 inches (150 mm) maximum above the horizontal grab bar, and 4 inches (100 mm) maximum inward from the front edge of the shower.

**Roll-in showers**

**608.3.2 Standard roll-in-type showers.** Grab bars in standard roll-in showers shall comply with Sections 608.3.2.1 through 608.3.2.3.

**Figure 608.3.2 (A)**

GRAB BARS IN STANDARD ROLL-IN-TYPE SHOWER  
ELEVATION

**Figure 608.3.2 (B)**

GRAB BARS IN STANDARD ROLL-IN-TYPE SHOWER  
PLAN

**608.3.2.1 Back-wall grab bar.** In standard roll-in type showers, a grab bar shall be provided on the back wall beginning at the edge of the seat. The grab bars shall not be provided above the seat. The back-wall grab bar shall extend the length of the wall and extend within 6 inches (150 mm) maximum from the adjacent side wall opposite the seat.

**Exceptions:**

1. The back wall grab bar shall not be required to exceed 48 inches (1220 mm) in length.
2. The back-wall grab bar is not required to extend within 6 inches (150 mm) of the adjacent side wall opposite the seat if it would require the grab bar length to exceed 48 inches (1220 mm) in length.

**608.3.2.2 Side-wall grab bars.** Where a side wall is provided opposite the seat within 72 inches (1830 mm) of the seat wall, a grab bar shall be provided on the side-wall opposite the seat. The side wall grab bar shall extend the length of the wall beginning 4 inches (100 mm) maximum from the front edge of the shower compartment and extend within 6 inches (150 mm) maximum from the adjacent back wall.

**Exception:** The side-wall grab bar shall not be required to exceed 30 inches (760 mm) in length and shall be located with one end within 6 inches of the adjacent back wall.

**608.3.2.3 Vertical grab bar.** Where a side wall is provided opposite the seat within 72 inches (1830 mm) of the seat wall a vertical grab bar shall be provided. A vertical grab bar 18 inches (455 mm) minimum in length shall be provided on the end wall 3 inches (75 mm) minimum and 6 inches (150 mm) maximum above the horizontal grab bar, and 4 inches (100 mm) maximum inward from the front edge of the shower.

**Alternate roll-in showers**

**608.3.3 Alternate roll-in-type showers.** In alternate roll-in type showers, grab bars shall be provided on the back wall and the side wall adjacent to the seat. Grab bars shall not be provided above the seat. Grab bars shall be 6 inches (150 mm) maximum from the adjacent wall.

**Figure 608.3.3 (A)**

GRAB BARS IN ALTERNATIVE TOLL-IN-TYPE SHOWER – ELEVATION

**Figure 608.3.3 (B)**



## SECTION 609 GRAB BARS

**609.1 General.** Grab bars in toilet or bathing facilities shall comply with Section 609.

**609.2 Cross section.** Grab bars shall have a cross section complying with Section 609.2.1 or 609.2.2.

### Figure 609.2

#### SIZE OF GRAB BARS

**609.2.1 Circular cross section.** Grab bars with a circular cross section shall have an outside diameter of 1<sup>1</sup>/<sub>4</sub> inch (32 mm) minimum and 2 inches (51 mm) maximum.

**609.2.2 Noncircular cross section.** Grab bars with a noncircular cross section shall have a cross section dimension of 2 inches (51 mm) maximum, and a perimeter dimension of 4 inches (100 mm) minimum and 4.8 inches (120 mm) maximum.

**609.3 Spacing.** The space between the wall and the grab bar shall be 1<sup>1</sup>/<sub>2</sub> inches (38 mm). The space between the grab bar and projecting objects below and at the ends of the grab bar shall be 1<sup>1</sup>/<sub>2</sub> inches (38 mm) minimum. The space between the grab bar and projecting objects above the grab bar shall be 12 inches (305 mm) minimum.

#### Exceptions:

1. The space between the grab bars and shower controls, shower fittings, and other grab bars above the grab bar shall be permitted to be 1<sup>1</sup>/<sub>2</sub> inches (38 mm) minimum.
2. Recessed dispensers projecting from the wall 1/4 inch (6.4 mm) maximum measured from the face of the dispenser and complying with Section 604.7 shall be permitted within the 12-inch (305 mm) space above and the 1<sup>1</sup>/<sub>2</sub>-inch (38 mm) spaces below and at the ends of the grab bar.

### Figure 609.3

#### SPACING OF GRAB BARS

**609.4 Position of grab bars.** Grab bars shall be positioned in accordance with Section 609.4.1, 609.4.2, or 609.4.3 as applicable.

**609.4.1 ~~General~~ Horizontal grab bars.** Grab bars ~~shall required to~~ be installed in a horizontal position ~~shall be~~ 33 inches (840 mm) minimum and 36 inches (915 mm) maximum above the floor measured ~~to the top of the gripping surface~~ ~~or shall be installed as required by Items 1 through 3.~~

#### Exception:

- ~~1. The height of the lower grab bar on the back wall of a bathtub shall comply with Section 607.4.1.1 or 607.4.2.1.~~
- ~~2. Vertical grab bars shall comply with Sections 604.5.1.2, 607.4.1.2.2, 607.4.2.2 and 608.3.1.2.~~
- ~~3. Grab bars at water closets primarily for children's use shall comply with Section 609.4.2.~~



**609.4.2 Vertical grab bars.** Grab bars required to be installed in the vertical position shall comply with Sections 604.5.1.2, 607.4.1.2.2, 607.4.2.2 and 608.3.1.2 as applicable. The location of vertical grab bars shall be measured horizontally to the center-line of the grab bar.

**609.4.2 609.4.3 Position of children's grab bars.** At water closets primarily for children's use complying with Section 604.11, grab bars shall required to be installed in a horizontal position shall be 18 inches (455 mm) minimum and 27 inches (685 mm) maximum above the floor measured to the top of the gripping surface. A vertical grab bar shall be mounted with the bottom of the bar located between 21 inches (535 mm) minimum and 30 inches (760 mm) maximum above the floor and with the centerline of the bar located between 34 inches (865 mm) minimum and 36 inches (915 mm) maximum from the rear wall.

**Figure 609.4.2 609.4.3 (A)**

POSITIONS OF CHILDREN'S GRAB BARS  
SIDE-WALL VIEW

**Figure 609.4.2 609.4.3 (B)**

POSITIONS OF CHILDREN'S GRAB BARS  
REAR-WALL VIEW

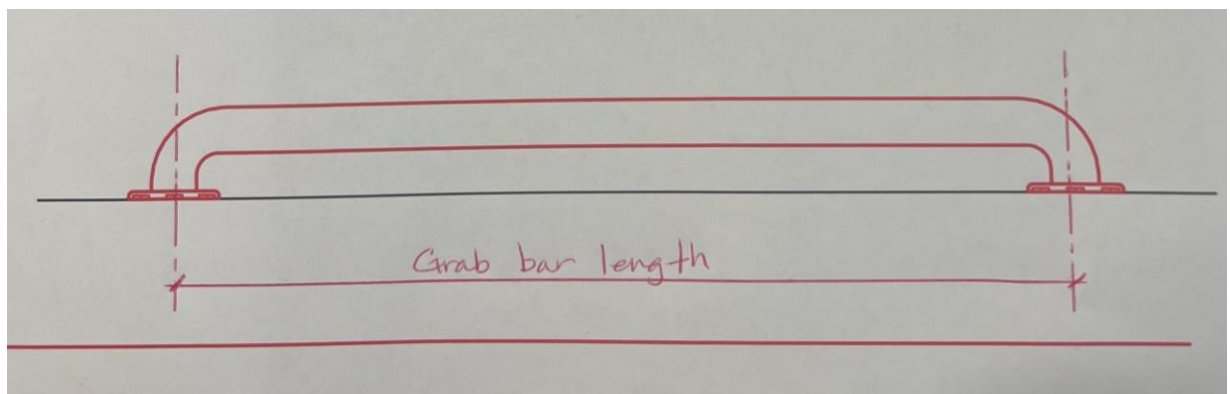
**609.5 Surface hazards.** Grab bars and any wall or other surfaces adjacent to grab bars shall be free of sharp or abrasive elements. Edges shall be rounded.

**609.6 Fittings.** Grab bars shall not rotate within their fittings.

**609.7 Installation and configuration.** Grab bars shall be installed in any manner that provides a gripping surface at the locations specified in this standard and does not obstruct the clear floor space. Horizontal and vertical grab bars shall be permitted to be separate bars, a single piece bar, or combination thereof.

**609.7.1 Length of grab bar.** The required length of a horizontal grab bar shall be measured horizontally to the center-line of the grab bar return. The required length of a vertical grab bar shall be measured vertically to the center -line of the grab bar return.

**Exception:** Where the grab bar extends past the wall supports, the required length of the grab bar shall be measured to the end of the grab bar.



**Figure 609.7.2(A)**

Grab bar length - Center-line of grab bar return

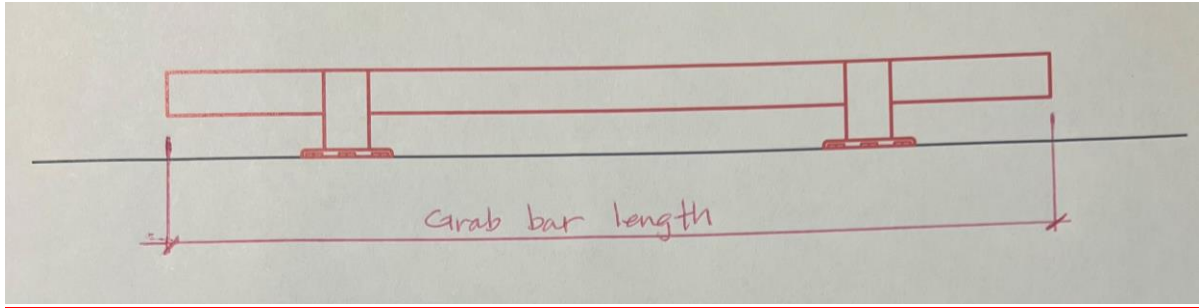


Figure 609.7.2(B)

Grab bar length - Example or exception

**609.8 Structural strength.** Allowable stresses shall not be exceeded for materials used where a vertical or horizontal force of 250 pounds (1112 N) is applied at any point on the grab bar, fastener mounting device, or supporting structure.

**Reason:** The intent it to uniformly call out the length and location of horizontal and vertical grab bars – height, length and where to measure.

6-43 – **Incorporated.** The intent of this proposal is the measurement to the top of the horizontal bar and the centerline of the vertical grab bar. Top of the horizontal bar is already in 609.4.1. Centerline of the vertical bar should also be stated there. Currently only indicated for toilets (604.5.1.2).

6-44 – **Incorporated.** If the intent of this proposal is to set a maximum distance from the front for the horizontal bars on the control wall for bathtubs. This should be uniformly applied for tubs and showers.

6-78 – **Incorporated.** We agree that splitting this into three sections makes the easier to understand than the current text. This allows for the location for the vertical grab bar to be set at the centerline. The propose text added too many words in the first sentence to avoid an exception. For vertical grab bars the proposal was not consistent in terms and used “and any object shall be measured from the object to the centerline of the bar”. This sounds more like an obstruction – which is addressed in spacing in 609.3. Location is covered enough in the existing text for each configuration.

6-79- **Oppose.** Same height for adjacent multiple bars on adjacent walls is addressed for showers in 608.3. The proposed text would be an issue for as written for bathtubs with two back wall grab bars. At water closets this could be an issue for access into the water closet tank for repairs. There is not technical justification for the ½” limitation.

6-80 – **Incorporated.** The intent it for how to measure for the end of the bars. Suggestions for cleaner language was added.

Committee Action: AM 25-1-3

## REPORT OF HEARING:

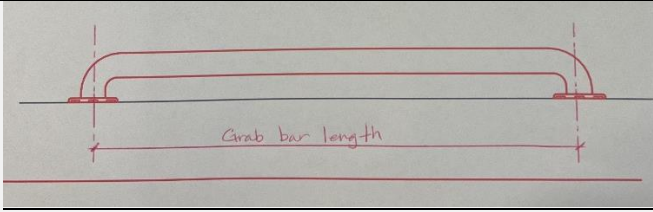
**Modification (if any):** See the replacement modification listed above.

**Committee Reason:** The modification combined the concerns for measuring the location and lengths of grab bars in proposals 06-43, 06-44, 06-78 and 06-80. The modifications provide consistent language for toilets, tubs and showers. The committee felt that this proposal clarified the intent of the provisions.

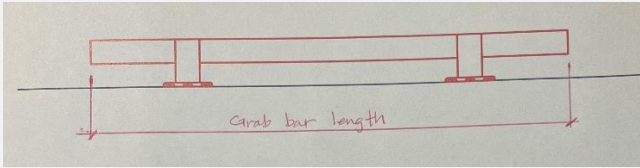
609.7.1-PAARLBERG.doc

Report for 06-80- 2021		
Committee decision: AM	Committee Vote at Meeting: 25-1-3	Committee Vote on Ballot:
<b>REPORT OF HEARING:</b> Modification (if any):		
<b>Replace with the following:</b>		
<p><b>604.5.1.2 Vertical grab bar.</b> A vertical grab bar 18 inches (455 mm) minimum in length shall be mounted with the bottom of the bar located 39 inches (990 mm) minimum and 41 inches (1040 mm) maximum above the floor, and <del>with the center line of the bar</del> located 39 inches (990 mm) minimum and 41 inches (1040 mm) maximum from the rear wall.</p>		
<p><b>607.4.1.2.1 Horizontal grab bar.</b> A horizontal grab bar 24 inches (610 mm) minimum in length shall be provided on the control end wall beginning <del>near 4 inches (100 mm) maximum from</del> the front edge of the bathtub and extending toward the inside corner of the bathtub.</p>		
<p><b>607.4.2.3 Head end wall.</b> A horizontal grab bar 12 inches (305 mm) minimum in length shall be provided on the head end wall <del>at beginning 4 inches (100 mm) maximum from</del> the front edge of the bathtub.</p>		
<p><b>608.3.1.1 Horizontal grab bars.</b> Horizontal grab bars shall be provided across the control wall <del>beginning 4 inches (100 mm) maximum from the front edge of the shower compartment</del> and on the back wall to a point 18 inches (455 mm) from the control wall.</p>		
<p><b>608.3.2.2 Side-wall grab bars.</b> Where a side wall is provided opposite the seat within 72 inches (1830 mm) of the seat wall, a grab bar shall be provided on the side-wall opposite the seat. The side wall grab bar shall extend the length of the wall <del>beginning 4 inches (100 mm) maximum from the front edge of the shower compartment</del> and extend within 6 inches (150 mm) maximum from the adjacent back wall.</p>		
<p><b>Exception:</b> The side-wall grab bar shall not be required to exceed 30 inches (760 mm) in length <del>and shall be located with one end within 6 inches of the adjacent back wall.</del></p>		
<p><b>609.4 Position of grab bars.</b> <del>Grab bars shall be positioned in accordance with Section 609.4.1, 609.4.2, or 609.4.3 as applicable.</del></p>		
<p><b>609.4.1 General Horizontal grab bars.</b> Grab bars <del>shall required to</del> be installed in a horizontal position <del>shall be</del> 33 inches (840 mm) minimum and 36 inches (915 mm) maximum above the floor measured to the top of the gripping surface <del>or shall be installed as required by Items 1 through 3.</del></p>		
<p><b>Exception:</b></p> <ol style="list-style-type: none"><li>1- The <del>height of the</del> lower grab bar on the back wall of a bathtub shall comply with Section 607.4.1.1 or 607.4.2.1.</li><li>2- <del>Vertical grab bars shall comply with Sections 604.5.1.2, 607.4.1.2.2, 607.4.2.2 and 608.3.1.2.</del></li><li>3- <del>Grab bars at water closets primarily for children's use shall comply with Section 609.4.2.</del></li></ol>		
<p><b>609.4.2 Vertical grab bars.</b> <del>Grab bars required to be installed in the vertical position shall comply with Sections 604.5.1.2, 607.4.1.2.2, 607.4.2.2 and 608.3.1.2 as applicable. The location of vertical grab bars shall be measured horizontally to the center-line of the grab bar.</del></p>		
<p><b>609.4.2 609.4.3 Position of children's grab bars.</b> At water closets primarily for children's use complying with Section 604.11, grab bars <del>shall required to</del> be installed in a horizontal position <del>shall be</del> 18 inches (455 mm) minimum and 27 inches (685 mm) maximum above the floor measured to the top of the gripping surface. A vertical grab bar shall be mounted with the bottom of the bar located <del>between</del> 21 inches (535 mm) minimum and 30 inches (760 mm) maximum above the floor and with the centerline of the bar located <del>between</del> 34 inches (865 mm) minimum and 36 inches (915 mm) maximum from the rear wall.</p>		
<p><b>Figure 609.4.2 609.4.3 (A)</b> POSITIONS OF CHILDREN'S GRAB BARS SIDE-WALL VIEW</p>		
<p><b>Figure 609.4.2 609.4.3 (B)</b> POSITIONS OF CHILDREN'S GRAB BARS REAR-WALL VIEW</p>		
<p><b>609.7.1 Length of grab bar.</b> <del>The required length of a horizontal grab bar shall be measured horizontally to the center-line of the grab bar return. The required length of a vertical grab bar shall be measured vertically to the center-line of the grab bar return.</del></p>		
<p><b>Exception:</b> <del>Where the grab bar extends past the wall supports, the required length of the grab bar shall be measured to the end of the grab bar.</del></p>		

**Report for 06-80– 2021**



**Figure 609.7.2(A)**  
Grab bar length - Center-line of grab bar return



**Figure 609.7.2(B)**  
Grab bar length - Example or exception

Committee Reason: The modification combined the concerns for measuring the location and lengths of grab bars in proposals 06-43, 06-44, 06-78 and 06-80. The modifications provide consistent language for toilets, tubs and showers. The committee felt that this proposal clarified the intent of the provisions.

**PUBLIC COMMENT- FIRST DRAFT:**

Proponent:

Desired Action:

Modification:

Reason:

**Committee decision: AS/AM/D**

**Committee Vote at Meeting:**

**Committee Vote on Ballot:**

**REPORT OF HEARING – FIRST DRAFT**

Modification (if any):

Committee Reason:

**PUBLIC COMMENT- SECOND DRAFT:**

Proponent:

Desired Action:

Modification:

Reason:

**Committee decision: AS/AM/D**

**Committee Vote at Meeting:**

**Committee Vote on Ballot:**

**FINAL ACTION:**

Modification (if any):

Committee Reason:

## **06-81 – 2021**

**610.2.1(New), 610.2.2(New), 610.2.3(New), Figures 610.2(A), 610.2(B), 610.2.3(New)**

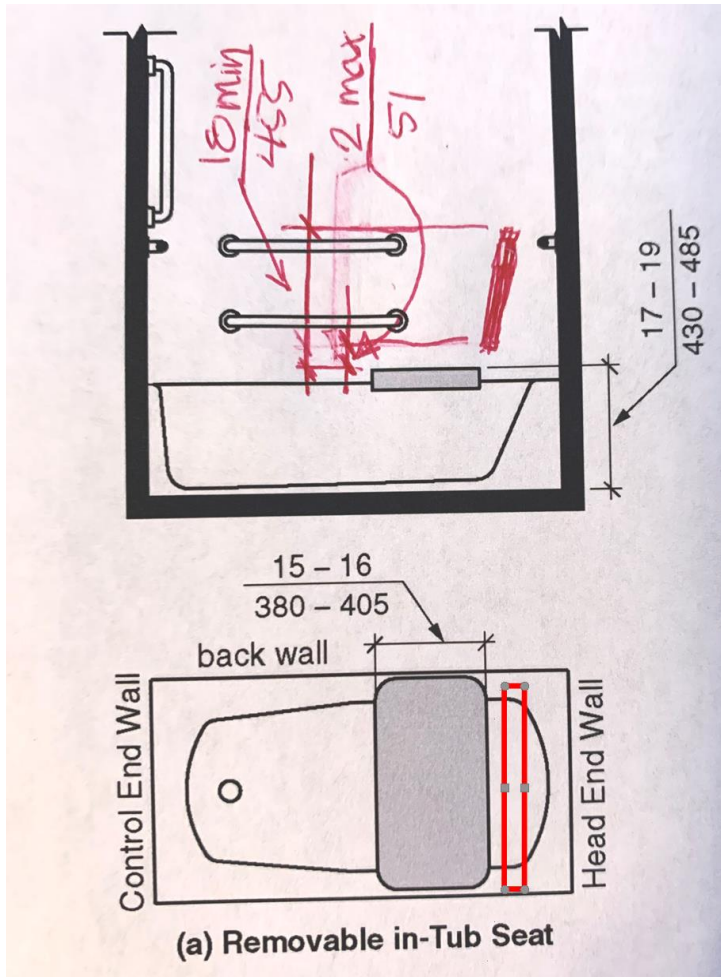
**Proponent:** Doug Anderson, representing A117.1 Accessible Bathing Task Group

**Revise as follows:**

### **SECTION 610 SEATS**

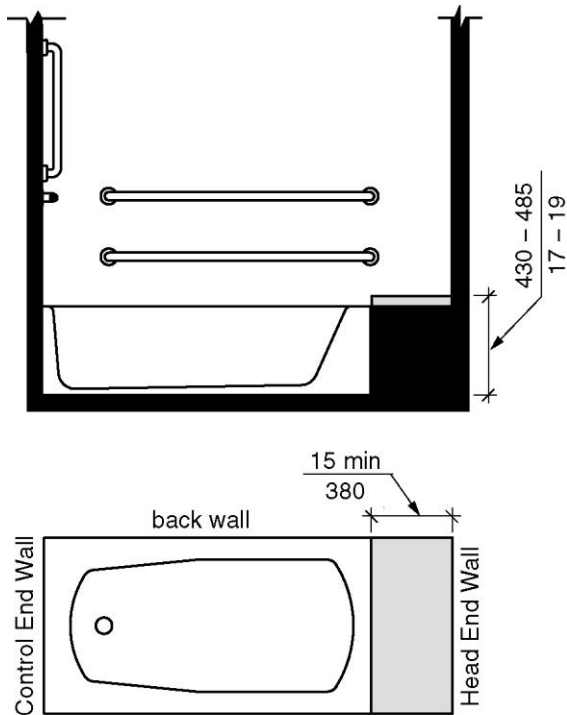
**610.2 Bathtub seats.** The height of bathtub seats shall be 17 inches (430 mm) minimum and 19 inches (485 mm) maximum above the bathroom floor, measured to the top of the seat.

**610.2.1 Removable in-tub seats.** Removable in-tub seats shall be 15 inches (380 mm) minimum and 16 inches (405 mm) maximum in depth and shall provide a back support that shall extend from a point 2 inches (51 mm) maximum above the seat surface to a point 18 inches (455 mm) minimum above the seat surface. Removable in-tub seats shall be capable of secure placement with the back edge of the seat positioned 35 to 37 inches from the foot control wall.



**FIGURE 610.2(A) 610.2.1  
BATHTUB SEATS  
REMOVABLE IN-TUB SEATS**

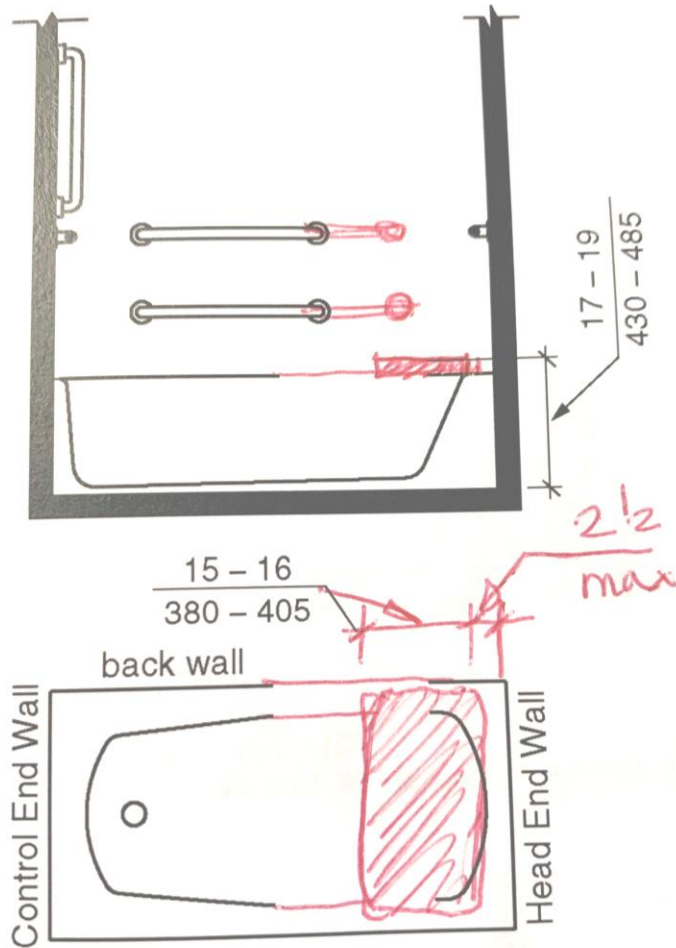
**610.2.2 Permanent Bathtub Seats.** Permanent bathtub seats shall be 15 inches (380 mm) minimum in depth and shall extend from the back wall to or beyond the outer edge of the bathtub. Permanent seats shall be positioned at the head end of the bathtub.



(b) Seat provided at head end of tub

**FIGURE 610.2(B) 610.2.2  
BATHTUB SEATS  
SEAT PROVIDED AT HEAD END OF TUB**

**610.2.3 Fixed folding in-tub seats.** Fixed folding in-tub seats must be rectangular and shall be mounted on the head wall. The rear edge of a rectangular seat shall be 21/2 inches (64 mm) maximum and the front edge shall be 15 inches (380 mm) minimum and 16 inches (405 mm) maximum from the head wall. The side edge of the seat shall be 11/2 inches (38 mm) maximum from the back wall.



(a) Removable in-Tub Seat

*Fixed folding*

**FIGURE 610.2.3**  
**BATHTUB SEATS**  
**FIXED FOLDING IN-TUB SEATS**

**REASON:** This proposal is seeking to provide better direction to the industry on the type and placement of tub seats. The photos are to illustrate what this proposal is talking about.





**Staff Note:** This proposal is from the A117.1 Accessible Bathing Task Group. Proposals 06-41, 06-42, 06-45, 06-50 and 06-81 are all related to bathtubs with a fixed folding in-tub seat.

**Committee Reason:** Committee Action: Disapproval 24-3-0

**REPORT OF HEARING:**

**Modification (if any):**

**Committee Reason:** Proposals 06-41, 06-42, 06-45, 06-50 and 06-81 are all related to bathtubs. Modifications to 06-41, 06-42 and 06-45 will replace the 5 proposal (separated by section) with 3 proposals (separated to one for each type of bathtub seat configuration).

This proposal was disapproved based on the committee actions for 06-41, 06-42 and 06-45.

**610.2-ANDERSON.doc**

<b>Report for 06-81– 2021</b>		
<b>Committee decision:</b> D	<b>Committee Vote at Meeting:</b> 24-3-0	<b>Committee Vote on Ballot:</b>
<b>REPORT OF HEARING:</b>		
Modification (if any):		
Committee Reason: Proposals 06-41, 06-42, 06-45, 06-50 and 06-81 are all related to bathtubs. Modifications to 06-41, 06-42 and 06-45 will replace the 5 proposal (separated by section) with 3 proposals (separated to one for each type of bathtub seat configuration).		
This proposal was disapproved based on the committee actions for 06-41, 06-42 and 06-45.		
<b>PUBLIC COMMENT- FIRST DRAFT:</b>		
Proponent:		
Desired Action:		
Modification:		
Reason:		
<b>Committee decision:</b> AS/AM/D	<b>Committee Vote at Meeting:</b>	<b>Committee Vote on Ballot:</b>
<b>REPORT OF HEARING – FIRST DRAFT</b>		
Modification (if any):		
Committee Reason:		
<b>PUBLIC COMMENT- SECOND DRAFT:</b>		
Proponent:		
Desired Action:		
Modification:		
Reason:		
<b>Committee decision:</b> AS/AM/D	<b>Committee Vote at Meeting:</b>	<b>Committee Vote on Ballot:</b>
<b>FINAL ACTION:</b>		
Modification (if any):		
Committee Reason:		



## 06-82 – 2021

### 610.3

**Proponent:** Ed Steinfeld, IDEA Center, University of Buffalo representing RESNA

**Revise as follows:**

#### SECTION 610 SEATS

**610.3 Shower Compartment Seats.** The height of shower compartment seats shall be 17 inches (430 mm) minimum and ~~19~~ 20 inches (~~485~~ 510 mm) maximum above the bathroom floor, measured to the top of the seat. In transfer-type and alternate roll-in-type showers, the seat shall extend along the seat wall to a point within 3 inches (75 mm) of the compartment entry. In standard roll-in-type showers, the seat shall extend from the control wall to a point within 3 inches (75 mm) of the compartment entry. Seats shall comply with Section 610.3.1 or 610.3.2.

**EXCEPTION:** An accessible seat which is adjustable in height shall be permitted where the seat is adjustable within a range of 15 inches (380 mm) minimum to 25 inches (635 mm) maximum, provided that at least one adjustment setting provides a seat within the range specified in this section.

---

**REASON:** The current standard does not reflect the findings of recent research. The existing dimensions are based on 1970's data. Since that time, new wheelchair technology, particularly the common use of cushions and other seating supports designed to reduce pressure ulcers and position people for improved social interaction and use of equipment, have led to increased seat heights. See Design Resources: Analysis of Seat Height for Wheeled Mobility Devices at <http://idea.ap.buffalo.edu/wp-content/uploads/sites/110/2019/08/23.pdf> The above proposed revision is consistent with this research.

Committee Action: split question – 610.3 AS 22-2-1; exception AS 11-12-2; D 17-4-3

#### **REPORT OF HEARING:**

**Modification (if any):**

**Further revise as follows:**

#### SECTION 610 SEATS

**610.3 Shower Compartment Seats.** The height of shower compartment seats shall be 17 inches (430 mm) minimum and 20 inches (510 mm) maximum above the bathroom floor, measured to the top of the seat. In transfer-type and alternate roll-in-type showers, the seat shall extend along the seat wall to a point within 3 inches (75 mm) of the compartment entry. In standard roll-in-

type showers, the seat shall extend from the control wall to a point within 3 inches (75 mm) of the compartment entry. Seats shall comply with Section 610.3.1 or 610.3.2.

~~**EXCEPTION:** An accessible seat which is adjustable in height shall be permitted where the seat is adjustable within a range of 15 inches (380 mm) minimum to 25 inches (635 mm) maximum, provided that at least one adjustment setting provides a seat within the range specified in this section.~~

**Committee Reason:** The committee split the question between the change in Section 610.3 and the exception. The allowance for the shower seat to be higher is based on the anthropometric study and would improve access for persons using a mobility aids with higher seats. The exception is not needed because someone would always choose to provide an option that improved access. In addition, there were concerns about the operation of an adjustable option without technical requirements.

**610.2-STEINFELD.doc**

<b>Report for 06-82– 2021</b>		
<b>Committee decision: AS/D</b>	<b>Committee Vote at Meeting: 22-2/17-4-3</b>	<b>Committee Vote on Ballot:</b>
<b>REPORT OF HEARING:</b>		
Modification (if any):		
<b>Further revise as follows:</b>		
<b>SECTION 610 SEATS</b>		
<b>610.3 Shower Compartment Seats.</b> The height of shower compartment seats shall be 17 inches (430 mm) minimum and 20 inches (510 mm) maximum above the bathroom floor, measured to the top of the seat. In transfer-type and alternate roll-in-type showers, the seat shall extend along the seat wall to a point within 3 inches (75 mm) of the compartment entry. In standard roll-in-type showers, the seat shall extend from the control wall to a point within 3 inches (75 mm) of the compartment entry. Seats shall comply with Section 610.3.1 or 610.3.2.		
<del><b>EXCEPTION:</b> An accessible seat which is adjustable in height shall be permitted where the seat is adjustable within a range of 15 inches (380 mm) minimum to 25 inches (635 mm) maximum, provided that at least one adjustment setting provides a seat within the range specified in this section.</del>		
Committee Reason: The committee split the question between the change in Section 610.3 and the exception. The allowance for the shower seat to be higher is based on the anthropometric study and would improve access for persons using a mobility aids with higher seats. The exception is not needed because someone would always choose to provide an option that improved access. In addition, there were concerns about the operation of an adjustable option without technical requirements.		
<b>PUBLIC COMMENT- FIRST DRAFT:</b>		
Proponent:		
Desired Action:		
Modification:		
Reason:		
<b>Committee decision: AS/AM/D</b>	<b>Committee Vote at Meeting:</b>	<b>Committee Vote on Ballot:</b>
<b>REPORT OF HEARING – FIRST DRAFT</b>		
Modification (if any):		
Committee Reason:		
<b>PUBLIC COMMENT- SECOND DRAFT:</b>		
Proponent:		
Desired Action:		
Modification:		
Reason:		
<b>Committee decision: AS/AM/D</b>	<b>Committee Vote at Meeting:</b>	<b>Committee Vote on Ballot:</b>
<b>FINAL ACTION:</b>		
Modification (if any):		
Committee Reason:		

## 06-83 – 2021

### 610.5(New)

**Proponent:** Gene Boecker, Code Consultants, Inc.

**Add new text as follows:**

#### SECTION 610 SEATS

**610.5 Projections.** Projections greater than 1/4 inch (6.4 mm) shall not be permitted within 42 inches (1065 mm) above the seat.

**Exception:** Grab bars complying with Section 608.3.1.

---

**REASON:** Elsewhere the grab bars are noted as not being allowed to extend over the seat. Except where the transfer shower has a specific dimension which could easily overlap the seat. Hence the exception. However, there is nothing specific about other types of projections such as soap dishes or shampoo dispensers. A review of available ergonomic dimensions shows that a height of 35 inches above the seat will be adequate to avoid contact where the projection is located on the wall behind the seat. An upward held hand can reach around 50 inches above the seat so 42 inches allows for both safety from the projection and the ability to reach the element. A soap dish could be less than 4 inches so a reference to Section 307 isn't helpful. It is also unlikely that anyone would consider a shower or bathtub a circulation path. Therefore, a specific height is needed.

An allowable projection of 1/4 inch is necessary to accommodate accent tile pieces within the shower. Typical ceramic tile is around 1/4 inch to 5/16 inch thick. Accent tiles tend to be close to 1/2 inch thick. This accommodates accent tile without prohibiting their use.

The exception recognizes that in a transfer shower the length of the grab bar is specified so it will overlap an L-shaped seat in the shower.

Committee Action: Disapproval 21-2-1

#### **REPORT OF HEARING:**

##### **Modification (if any):**

**Committee Reason:** The proposal was disapproved because the committee felt that this was not needed and/or potentially too stringent. This could be misinterpreted for tile or textured walls with grout lines or gaps. There was a question of if the concern was more about sharp and abrasive surfaces rather than small changes in level.

**610.5-BOECKER.doc**

---

<b>Report for 06-83– 2021</b>		
<b>Committee decision: D</b>	<b>Committee Vote at Meeting: 21-2-1</b>	<b>Committee Vote on Ballot:</b>
<b>REPORT OF HEARING:</b>		
Modification (if any):		
Committee Reason: The proposal was disapproved because the committee felt that this was not needed and/or potentially too stringent. This could be misinterpreted for tile or textured walls with grout lines or gaps. There was a question of if the concern was more about sharp and abrasive surfaces rather than small changes in level.		
<b>PUBLIC COMMENT- FIRST DRAFT:</b>		
Proponent:		
Desired Action:		
Modification:		
Reason:		
<b>Committee decision: AS/AM/D</b>	<b>Committee Vote at Meeting:</b>	<b>Committee Vote on Ballot:</b>
<b>REPORT OF HEARING – FIRST DRAFT</b>		
Modification (if any):		
Committee Reason:		
<b>PUBLIC COMMENT- SECOND DRAFT:</b>		
Proponent:		
Desired Action:		
Modification:		
Reason:		
<b>Committee decision: AS/AM/D</b>	<b>Committee Vote at Meeting:</b>	<b>Committee Vote on Ballot:</b>
<b>FINAL ACTION:</b>		
Modification (if any):		
Committee Reason:		

## **06-84 – 2021**

**611(New)**

**Proponent:** Amy Carpenter, representing Assisted Toileting and Bathing work group

**Add new text as follows:**

### **SECTION 611** **ASSISTED TOILET AND BATHING ROOMS**

**611.1 General.** Individual use bathrooms for assisted toileting and bathing shall comply with Section 611.

**611.2 Clearances.**

**611.2.1 Turning Space.** A turning space shall be provided within the room.

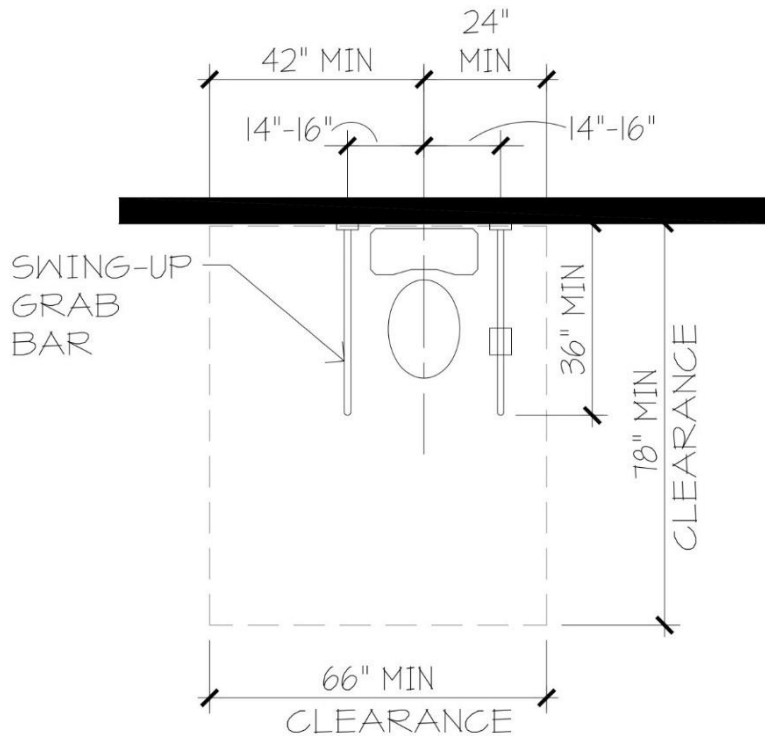
**611.2.2 Door Swing.** Doors shall not swing into the bathroom.

**Exception:** Where a clear floor space complying with Section 305.3 is provided in the room beyond the arc of the door and emergency rescue door hardware, that allows the door to be swung out of the room, is provided.

**611.3 Mirrors.** A mirror shall be mounted with the bottom edge of the reflecting surface 40 inches (1015 mm) maximum above the floor.

**611.4 Coat Hooks.** Coat hooks shall be located within one of the reach ranges specified in Section 308.

**611.5 Water Closets.** Water closets for assisted toileting shall comply with Section 611.5.



**FIGURE 611.5**  
**ASSISTED USE WATER CLOSET**

**611.5.1 Clearance width.** Clearance around the water closet shall be 66 inches (1676 mm) minimum. A minimum dimension of 24 inches (609 mm) shall be provided on each side, measured from the centerline of the water closet.

**611.5.2 Clearance depth.** Clearance around the water closet shall be 78 inches (1981 mm) minimum in depth, measured perpendicular from the rear wall.

**611.5.3 Clearance overlap.** The required clearance around the water closet shall be permitted to overlap the water closet, associated grab bars, paper dispensers, sanitary napkin receptacles, coat hooks, shelves, accessible routes, clear floor space at other fixtures and the turning space. Towel bars that meet the strength requirements of Section 609.8 shall be permitted to overlap the clearance at the water closet. No other obstructions shall be within the required water closet clearance.

**611.5.4 Height.** The height of the water closet shall comply with Section 604.4

**611.5.5 Grab bars.** Grab bars for assisted toileting shall comply with Sections 611.5.5.1 through 611.5.5.6

**611.5.5.1** Swing up grab bars shall be provided at both sides of the water closet.



611.5.5.2 Swing up grab bars shall be located 14 to 16 inches (355 to 406 mm) from the centerline of the water closet.

611.5.5.3 Swing up grab bars shall extend a minimum of 36 inches (915 mm), measured perpendicular from the rear wall to the furthest projection of the bar.

611.5.5.4 The height of the Swing up grab bar, when in the down position, shall be 30 inches (760 mm) minimum and 34 inches (865 mm) maximum measured from the floor to the topmost portion of the bar.

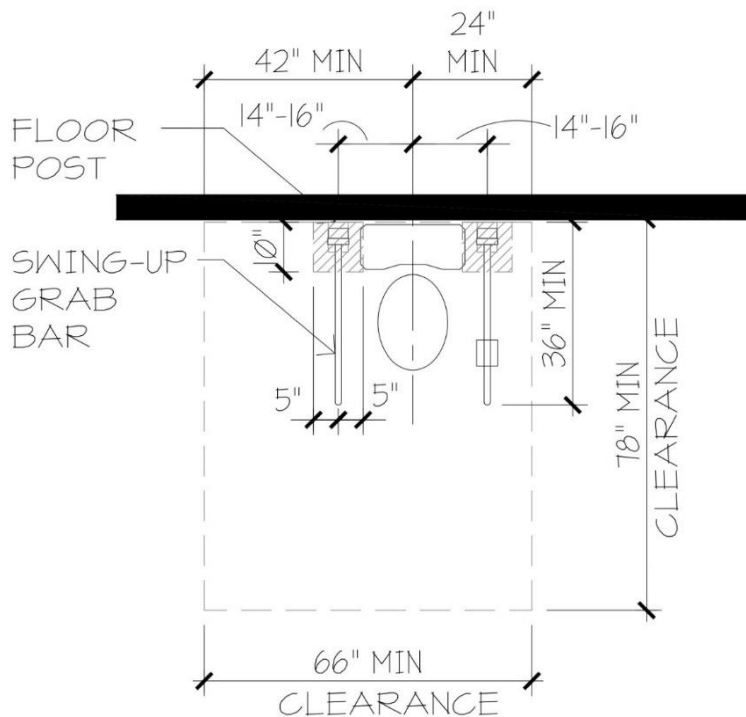
611.5.5.5 Swing up grab bars shall meet structural strength requirements per Section 609.8.

Exception: Swing up bars are not required to resist required forces when being moved upward to the vertical position.

611.5.5.6 A floor-mounted support post, complying with Section 611.5.6 shall be permitted as an alternate to mounting swing up grab bars directly to a reinforced wall behind the toilet.

611.5.6 Floor-mounted support post. A floor-mounted support post, used as an alternate means of support for swing up grab bars shall be designed to meet the structural strength requirements of Section 609.8 and shall be permitted to be located within the clearance around the water closet provided it meets all of the following:

1. The floor plate and post shall not extend more than 10 inches (254 mm) in depth measured perpendicular to the back wall,
2. The floor plate and post shall not extend more than 5 inches (127 mm) in width, measured from the centerline of the grab bar to either side,
3. The post location shall not block access to the flush controls, and
4. The floor plate and post shall not overlap any other required clearances or turning space.



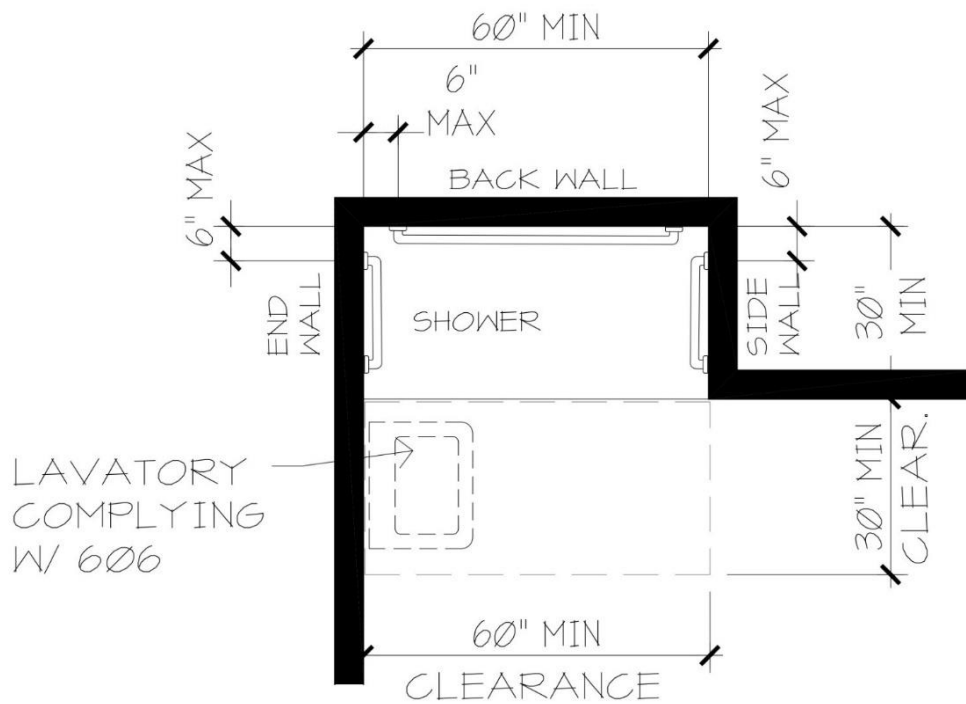
**FIGURE 611.5.6**  
**ASSISTED USE WATER CLOSET**  
**FLOOR-MOUNTED SUPPORT POSTS**

**611.5.7 Flush Controls.** Flush controls shall comply with Section 604.6

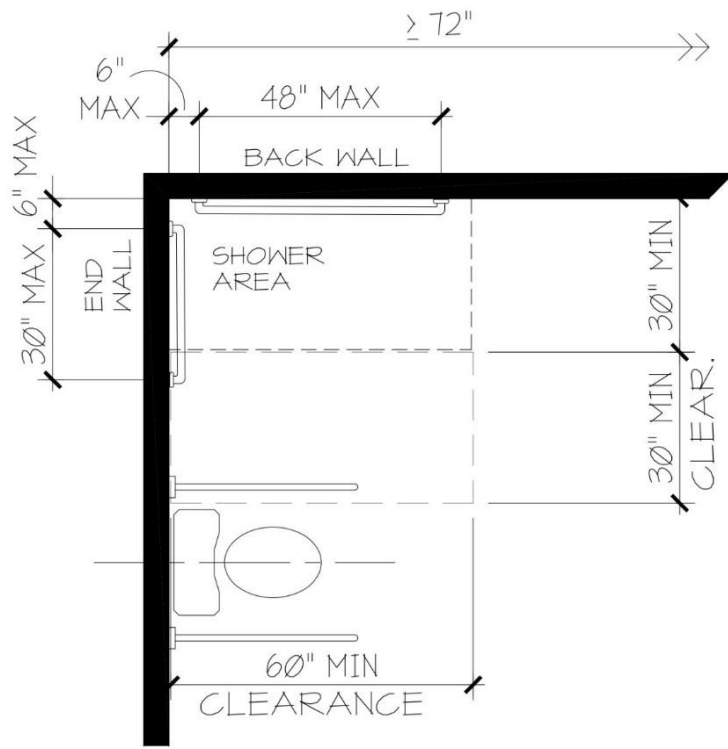
**611.5.8 Dispensers.** Toilet paper dispensers shall be mounted on at least one of the swing up grab bars and shall be located at 24 inches (610 mm) minimum to 36 inches (915 mm) maximum measured perpendicular to the rear wall. Dispensers shall not be of a type that control delivery or do not allow continuous paper flow.

**611.6 Lavatories and Sinks.** Where a lavatory or sink is provided inside the room used for assisted toileting and bathing, it shall comply with Section 606.

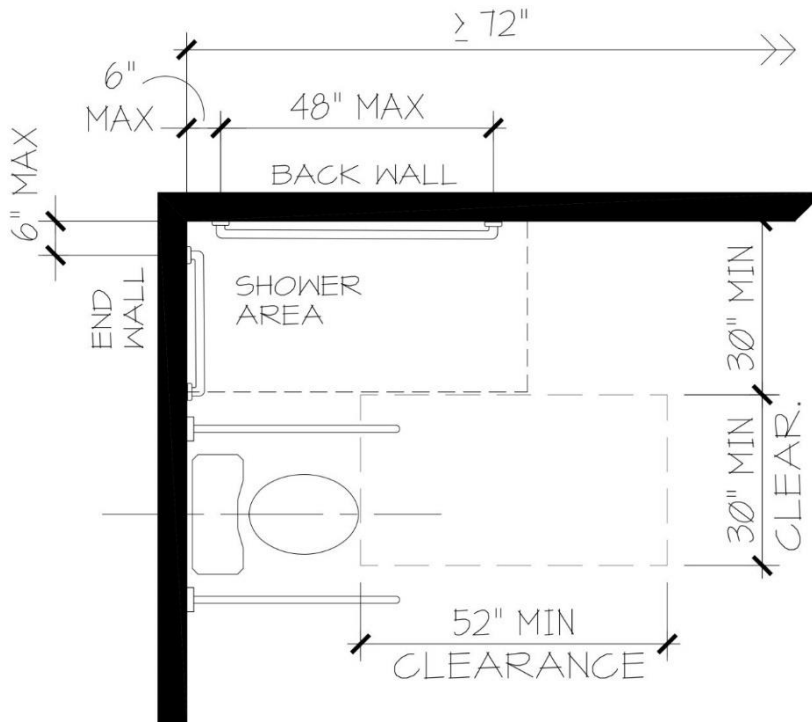
**611.7 Showers.** Roll-in showers for assisted bathing shall comply with Section 611.7.



**FIGURE 611.7(A)**  
**ROLL-IN SHOWERS FOR ASSISTED BATHING**  
**OPTION 1**



**FIGURE 611.7(B)**  
**ROLL-IN SHOWERS FOR ASSISTED BATHING**  
**OPTION 2**



**FIGURE 611.7(C)**  
**ROLL-IN SHOWERS FOR ASSISTED BATHING**  
**OPTION 3**

**611.7.1 Size.** A roll-in shower area for assisted bathing shall have a clear inside dimension of 60 inches (1525 mm) minimum in length and 30 inches (760 mm) minimum in depth, measured at the center point of opposing sides.

**611.7.2 Clearance.** A clearance of 60 inches (1525 mm) minimum in length adjacent to the long side of the shower area, and 30 inches (760 mm) minimum in depth, shall be provided.

**Exceptions:**

1. A lavatory complying with Section 606 shall be permitted at one end of the clearance
2. Where the shower area exceeds minimum sizes, the clear floor space shall be placed 30 inches (760 mm) minimum from the back wall and the length shall be parallel to the back wall.

**611.7.3 Seat.** A fixed folding or non-folding wall-mounted seat is not permitted.

**611.7.4 Grab bars.** Grab bars shall comply with Section 609 and shall be provided in accordance with Section 611.7.4.1

**611.7.4.1** Horizontal grab bars in roll-in showers for assisted bathing shall be provided on the back wall, end wall and side wall. Grab bars shall extend within 6 inches (150 mm) maximum from adjacent walls.

**Exceptions:**

1. The back-wall grab bar shall not be required to exceed 48 inches (1220 mm) in length.
2. End-wall and side-wall grab bars shall not be required to exceed 30 inches (760 mm) in length.
3. If the back-wall length is 72 inches (1830 mm) or greater, a side-wall grab bar is not required.

**611.7.5 Controls.** On/off and temperature adjustment controls for roll-in showers for assisted bathing shall comply with Section 309.4 and shall comply with all of the following:

1. Installed at a height of 38 inches (965 mm) minimum and 48 inches (1220 mm) maximum above the shower floor,
2. Located either on the end wall or side wall, 18 inches (455 mm) minimum and 48 inches (1220 mm) maximum from the back wall, and
3. Located to allow access by a caregiver and minimize reaching through the water stream

**Exception:** Where the back wall length is 72 inches (1830 mm) or greater, controls are permitted to be located on the back wall at a height of 38 inches (965 mm) minimum and 48 inches (1220 mm) maximum above the shower floor and 27 inches (685 mm) minimum and 60 inches (1525 mm) maximum from the end wall.

**611.7.6 Hand Showers.** At least one hand shower complying with Section 309.4, Section 608.5 and Section 611.7.6 shall be provided in roll-in showers for assisted bathing. The hand shower shall be located:

1. At a height of 38 inches (965 mm) minimum and 48 inches (1220 mm) maximum above the shower floor, and
2. On the end wall, back wall or side wall within the shower area.

**611.7.7 Thresholds.** Thresholds in roll-in showers for assisted bathing shall comply with Section 608.6

**611.7.8 Shower enclosures.** Shower area enclosures shall not obstruct access to controls or hand shower from outside the shower area. Floor mounted enclosures shall maintain a minimum clear opening width of 41.5 inches (1054 mm) with no added threshold.

**611.7.9 Water Temperature.** Water Temperature shall comply with Section 608.8.

---

**REASON:** This proposed new section is meant to provide an alternative compliance path for a percentage of the fully accessible units that are required in Nursing Homes and Assisted Living

residences. These changes are specifically aimed at addressing the needs of older adults who live in care settings (receiving custodial care and/or medical care). It is our intent that Owners/Operators of these care settings can choose have some units comply with these alternatives in lieu of complying with traditional accessible unit requirements. A rehabilitation facility that serves primarily younger people, with spinal cord injuries, would likely not choose to have any units meet this alternate standard. However, many nursing homes serving elders, where the average age of resident is usually around 88 – 90 years old, would likely choose to have as many units as possible meet this alternate standard.

The 2021 International Building Code, Chapter 11 introduced these measures into the code as the deadline for inclusion in the last edition of the Standard had passed. We are hoping to include this language in the Standard this cycle and remove the language from IBC Chapter 11. The ICC A117.1 committee approved a work group to develop criteria for assisted toileting and bathing. Meetings were held every two weeks and were open to the public. In addition to the members of the task group, there was participation by a variety of interested parties. The language contained within this proposal was developed and reviewed by the work group and a consensus was reached.

The language contained in this proposal is based on research sponsored by the Mayer-Rothschild Foundation as well as direct experience and feedback from caregivers and gerontologists, along with the input of the task group. The intent of the language is to be flexible to cover the needs of elders as they decline in ability over time and gradually need more support and caregiver assistance in all activities of daily living. While they may be able to independently shower or transfer to the toilet when they first move in to a care community, their needs do increase over time. Many do become completely dependent on assistance by one or more caregivers. The proposal seeks to strike a balance between the accessibility needs of both the elder resident as well as the needs of the care staff.

It was decided to place all requirements around assisted bathing and toileting into a distinct section to aid with use of the Standard and keep all requirements together. If the Committee would prefer to disperse the requirements into Section 604 and 608, we would be OK with that change.

### **Assisted toileting:**

Current existing accessibility provisions contained in the standard do not adequately the needs of older adults as they lose upper body strength and mobility. They simply do not have the strength to use wall-mounted grab bars at toilets to accomplish a transfer. Additionally, many have balance issues that require additional support on both sides of the toilet. Further, most residents in care settings, although they may use wheelchairs for mobility, still have some use of their legs and most can bear weight on one or both legs. Therefore, the requirements meant to address the needs fully paralyzed or quadriplegic persons is not necessarily beneficial to elders.

A search of CMS data shows only 1% of residents in nursing homes, nationwide, have a diagnosis of quadriplegia or paraplegia. With a minimum of 50% of nursing home resident rooms being required to meet current standards, an average of 49% of these rooms are simply not working well for the residents who live there. Falls in bathrooms are one of the largest risks of injury and death in nursing homes.

Research sponsored by the Mayer-Rothschild foundation studied how elders in care settings transfer on and off the toilet, both independently and with staff assistance. The dimensions and clearances contained in this proposal are all based on these recommendations. Most important is

the additional space provided on both sides of the toilet over the traditional 18 inches contained in the Standard. This added space is critical for allowing care staff to stand alongside the toilet to assist with sitting and standing without injuring themselves. This additional clearance around the toilet also makes maneuvering of various lift devices easier, along with giving residents using mobility devices more space to maneuver.

The inclusion of a floor mounted support post to attach the swing-up grab bars to was considered to be an important component for both new and existing construction. The Rothschild study calls for the grab bar to extend 6-9" beyond the front edge of the toilet. With most elongated bowl toilets extending approximately 30 inches from the back wall, this requires a minimum length swing-up bar at 36", which is difficult to find on the market today. This also brought up concerns about structural stability of wall blocking and proper connections. One of the task group alerted the group to the support posts that are currently available on the market. Benefits of the support post include the ability to use standard, shorter swing-up bars to still achieve the desired distance in front of the toilet, better structural stability, and the ability of users to better customize the height of the mounting to their specific needs. (people do shrink as they age)

Research and practical experience showed the task group that very few lifetime wheelchair users complete a side-slide transfer with the wheelchair completely parallel to the toilet and the back wheels all the way back to the rear wall. The majority of wheelchair users angle towards the toilet, using the space in front and to the side of the toilet. With elders who can bear weight and stand to transfer, the space adjacent to the toilet along the rear wall is rarely accessed or needed. In addition, the toilet tank or space for the flush valve assembly push the "seat" of the toilet out a certain distance from the wall. It was felt that a floor mounted post and associated mounting plate could overlap the clearance around the toilet by a small amount, provided that the flush controls were still easily accessed.

### **Assisted Bathing:**

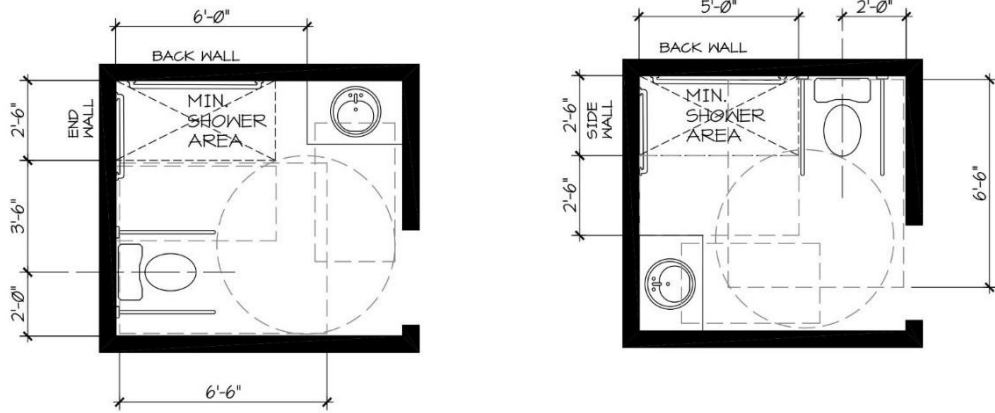
Many residents in Assisted Living and Nursing Home care settings are assisted, to varying levels, with their bathing activities as they may not be able to safely accomplish this on their own. Traditionally, roll-in-type showers have been used in care settings because of the ease of access they provide (low/no threshold). However, there are some requirements in the current Standard that can make it more difficult for care staff to assist with bathing.

For example, a wall mounted seat can be difficult for an elder to transfer on and off and many are fearful of falling off. Additionally, with the seat against the side wall and back wall, it is difficult, if not impossible for a caregiver to adequately access and wash all parts of a resident. For this reason, wall mounted seats are typically folded up and a mobile shower chair or stool is brought in. However, the folded seat still takes up space, and there are sharp edges and protrusions that can tear delicate elder skin or cause other injuries to the resident or caregiver. Mobile shower chairs are also better as they have arms that provide support and balance assistance for residents when standing/sitting and while seated. Caregivers can either turn the resident's chair while bathing, or walk around the person in the chair to be able to reach and wash all areas.

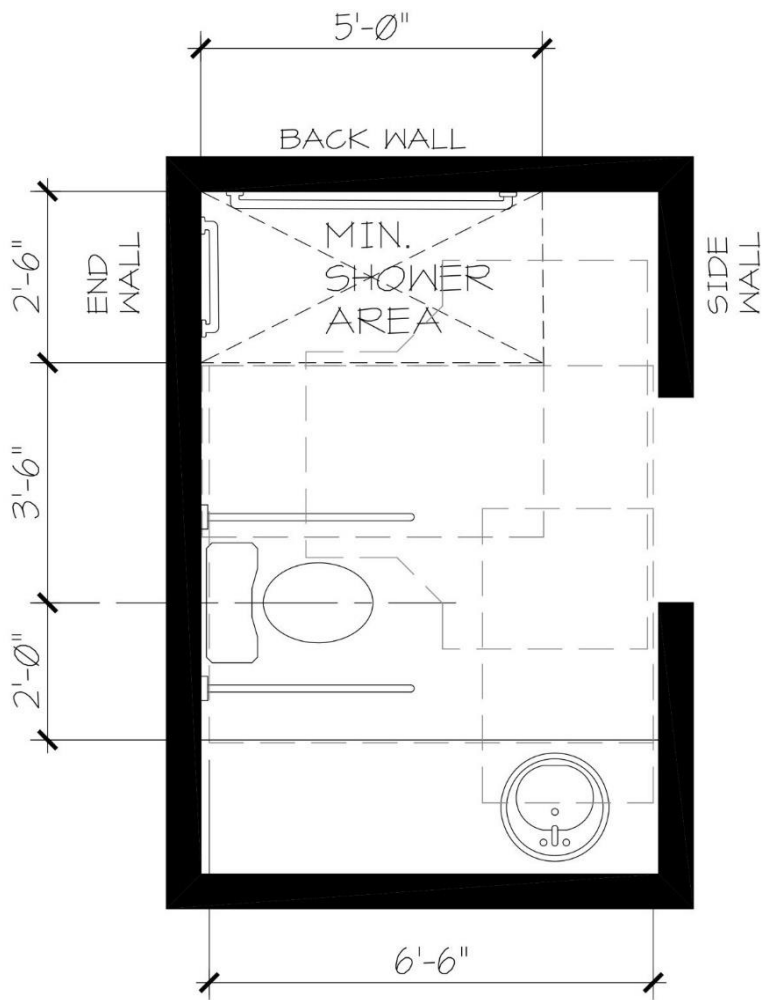
Similarly, the location of the controls on the back wall of a standard roll-in shower makes it more difficult for a caregiver to access them to turn the water on/off as well as to adjust the temperature during a shower. They either need to reach across the resident being bathed, which is awkward, or often need to reach through the water stream, which gets them wet. Some people







**Sample Bathroom layout C & D**



**Sample bathroom layout E**

Committee Action: Approved as submitted (31-1-3)  
**REPORT OF HEARING:**  
**Modification (if any):**

**Committee Reason:** The committee felt the research for proposal included valid information for assisted transfers. It is appropriate to limit this application to locations where people are not strong enough to self-transfer, such as assisted living facilities, nursing homes and rehabilitation facilities (which is the current scoping in the IBC). It was requested that the committee look at the language in Section 611.7.4.1 regarding the length of the grab bars – ‘minimum’ may be confusing.

**Staff note:** Editorial - Title added to Section 611.7.9.

**611 NEW-CARPENTER.doc**

<b>Report for 06-84- 2021</b>		
<b>Committee decision: AS</b>	<b>Committee Vote at Meeting: 31-1-3</b>	<b>Committee Vote on Ballot:</b>
<b>REPORT OF HEARING:</b>		
Modification (if any):		
Committee Reason: The committee felt the research for proposal included valid information for assisted transfers. It is appropriate to limit this application locations where people are not strong enough to self-transfer, such as assisted living facilities, nursing homes and rehabilitation facilities. It was requested that the committee look at the language in Section 611.7.4.1 regarding the length of the grab bars – ‘minimum’ may be confusing.		
<b>PUBLIC COMMENT- FIRST DRAFT:</b>		
Proponent:		
Desired Action:		
Modification:		
Reason:		
<b>Committee decision: AS/AM/D</b>	<b>Committee Vote at Meeting:</b>	<b>Committee Vote on Ballot:</b>
<b>REPORT OF HEARING – FIRST DRAFT</b>		
Modification (if any):		
Committee Reason:		
<b>PUBLIC COMMENT- SECOND DRAFT:</b>		
Proponent:		
Desired Action:		
Modification:		
Reason:		
<b>Committee decision: AS/AM/D</b>	<b>Committee Vote at Meeting:</b>	<b>Committee Vote on Ballot:</b>
<b>FINAL ACTION:</b>		
Modification (if any):		
Committee Reason:		

# 06-85 – 2021

## 611.2

**Proponent:** Tami Kump, Knothe Bruce Architects, LLC

**Revise as follows:**

### SECTION 611 WASHING MACHINES AND CLOTHES DRYERS

**611.2 Clear floor space.** A clear floor space positioned for parallel approach shall be provided. For top loading machines, the clear floor space shall be centered on the appliance. For front loading machines, the centerline of the clear floor space shall be offset 24 inches (610 mm) maximum from the centerline of the door opening.

Where only one washer and one dryer are provided in a side-by-side configuration, the appliance doors in the open position shall not obstruct the clear floor space for the adjacent appliance.

---

**REASON:** When a washer and a dryer are separate pieces of equipment, the clear floor space requirements are for the individual machines, but, when it comes to functionality, a washer and dryer are more typically used as a unit. When thinking about how they function together, it becomes clear on how an open door(s) that falls between the two machines could make a daily task unnecessarily difficult for a person with restricted mobility.

When an appliance door opens toward the adjacent machine (which would overlap the CFS when open), one must first position themselves in front of that machine to gain the proper leverage to open the door, then they must maneuver back into a position that allows for the transfer of laundry from one machine to the other. The need to lift heavy, wet clothing over an open door(s) that overlaps the clear floor space may be cumbersome and difficult while also maintaining a position for the required leverage it takes to get the clothing into the front-loading dryer. The door would also be an obstruction if one dropped a piece of clothing and had to pick it up.

The requirement I am proposing would be especially important when the doors to the machines do not open 180 degrees. Most machines manufactured today come from the factory with the dryer door hinge on the right side of the machine but have the capability to reverse the swing of the doors. This seems like an easy requirement to meet, or at least gets the designer to think about the adjacency of the washer and dryer relative to how the machines are used.

Committee Action: Disapproved 25-0-3

#### **REPORT OF HEARING:**

**Modification (if any):**

**Committee Reason:** There are enforcement issues (not measurable or consistent) because laundry equipment is not built in, so enforcement would be a guess based on assumed equipment. Two front loads with doors facing each other would not have space for a clear floor space in between, so there was a question about if toe space could go under the door and comply with “not obstruct”. Moving laundry from one machine to another easily is better in commentary than as a requirement.

611.2-KUMP.doc

<b>Report for 06-85– 2021</b>		
<i>Committee decision: D</i>	<i>Committee Vote at Meeting: 25-0-3</i>	<i>Committee Vote on Ballot:</i>
<b>REPORT OF HEARING:</b>		
Modification (if any):		
Committee Reason: There are enforcement issues (not measurable or consistent) because laundry equipment is not built in, so enforcement would be a guess based on assumed equipment. Two front loads with doors facing each other would not have space for a clear floor space in between, so there was a question about if toe space could go under the door and comply with “not obstruct”. Moving laundry from one machine to another easily is better in commentary than as a requirement.		
<b>PUBLIC COMMENT- FIRST DRAFT:</b>		
Proponent:		
Desired Action:		
Modification:		
Reason:		
<i>Committee decision: AS/AM/D</i>	<i>Committee Vote at Meeting:</i>	<i>Committee Vote on Ballot:</i>
<b>REPORT OF HEARING – FIRST DRAFT</b>		
Modification (if any):		
Committee Reason:		
<b>PUBLIC COMMENT- SECOND DRAFT:</b>		
Proponent:		
Desired Action:		
Modification:		
Reason:		
<i>Committee decision: AS/AM/D</i>	<i>Committee Vote at Meeting:</i>	<i>Committee Vote on Ballot:</i>
<b>FINAL ACTION:</b>		
Modification (if any):		
Committee Reason:		

## 06-86 – 2021

### 611.3, 611.4

**Proponent:** Kimberly Paarlberg, International Code Council

**Revise as follows:**

#### SECTION 611 WASHING MACHINES AND CLOTHES DRYERS

**611.1 General.** Washing machines and clothes dryers shall comply with Section 611.

**611.2 Clear floor space.** A clear floor space positioned for parallel approach shall be provided. For top loading machines, the clear floor space shall be centered on the appliance. For front loading machines, the centerline of the clear floor space shall be offset 24 inches (610 mm) maximum from the centerline of the door opening.

**611.3 Operable parts.** Operable parts, including doors, lint screens, detergent and bleach compartments, shall comply with Sections 308 and 309.

**Exception Exceptions:**

1. The height of the obstruction in Section 308.3.2 shall be permitted to be 36 inches (915 mm) maximum above the floor.
2. The operable part of the door shall be permitted to be 54 inches (1372 mm) maximum above the floor.

**611.4 Height.** Top loading machines shall have the door to the laundry compartment 36 inches (915 mm) maximum above the floor. ~~Front loading machines shall have the bottom of the opening to the laundry compartment 15 inches (380 mm) minimum and 36 inches (915 mm) maximum above the floor.~~

---

**REASON:** There are many stackable machines that save space and offer improved access with center controls. Previously the stackables had separate controls, instead of the new center control, so the controls were not within reach range. Options are now available with the controls within reach, but the dryer compartment is above 36 inches. This intent of this proposal is to increase design options within dwelling units. Setting the control for the door at 54" which is typically the center, would set the bottom of the door below that. Below are examples I found at the local home improvement store. The controls in the center seemed to provide better access than a top loading machine. These are models from LG, Equator and Whirlpool.



Committee Action: As submitted 21-1-5

**REPORT OF HEARING:**

**Modification (if any):**

**Committee Reason:** This would allow stackable washers and dryers for smaller and efficiency apartments. Reach into the top drum would be easier than in a top loading machine.

611.4-PAARLBERG.doc

<b>Report for 06-86- 2021</b>		
<i>Committee decision: AS</i>	<i>Committee Vote at Meeting: 21-1-5</i>	<i>Committee Vote on Ballot:</i>
<b>REPORT OF HEARING:</b>		
Modification (if any):		
Committee Reason: This would allow stackable washers and dryers for smaller and efficiency apartments. Reach into the top drum would be easier than in a top loading machine.		
<b>PUBLIC COMMENT- FIRST DRAFT:</b>		
Proponent:		
Desired Action:		
Modification:		
Reason:		
<i>Committee decision: AS/AM/D</i>	<i>Committee Vote at Meeting:</i>	<i>Committee Vote on Ballot:</i>
<b>REPORT OF HEARING – FIRST DRAFT</b>		
Modification (if any):		
Committee Reason:		
<b>PUBLIC COMMENT- SECOND DRAFT:</b>		
Proponent:		
Desired Action:		
Modification:		
Reason:		
<i>Committee decision: AS/AM/D</i>	<i>Committee Vote at Meeting:</i>	<i>Committee Vote on Ballot:</i>
<b>FINAL ACTION:</b>		
Modification (if any):		
Committee Reason:		

# 06-87 – 2021

## 611.4

**Proponent:** Marsha Mazz, United Spinal Association

**Revise as follows:**

### SECTION 611 WASHING MACHINES AND CLOTHES DRYERS

**611.4 Height.** Top loading machines shall not be permitted ~~have the door to the laundry compartment 36 inches (915 mm) maximum above the floor.~~ Front loading machines shall have the bottom of the opening to the laundry compartment 15 inches (380 mm) minimum and 36 inches (915 mm) maximum above the floor.

---

**REASON:** We find that top loading machines are not very usable by individuals seated in wheelchairs. To reach items in the tub, they must use an auxiliary aid such as a reaching tool or “grabber” but, often, they cannot see the target at the bottom of the tub. Also, people with disabilities affecting their manual dexterity often cannot use these tools because their trigger style operators typically require tight grasping and one must rotate their wrist to pick-up an item – see <https://www.seniormatter.com/review-the-best-grabber-reacher/2491052> for examples of this equipment or search for “reaching tool”. One model which is approximate ten times the typical cost of other models allows for the device to be attached to the arm – see [https://www.rehab-store.com/p-quad-reacher.html?gclid=CjwKCAjw6fCCBhBNEiwAem5SO5cqXAZRmP46fUgQo7j0na4DvC-gOyD-KY8d54h2MuDPDSqgZONZBBoCthEQAvD\\_BwE](https://www.rehab-store.com/p-quad-reacher.html?gclid=CjwKCAjw6fCCBhBNEiwAem5SO5cqXAZRmP46fUgQo7j0na4DvC-gOyD-KY8d54h2MuDPDSqgZONZBBoCthEQAvD_BwE).

Committee Action: As submitted 15-12-4

#### REPORT OF HEARING:

**Modification (if any):** The proposal was approved because it is difficult to reach laundry by a seated person in the bottom of the drum in top loading equipment. There were concerns that there would be an enforcement issue because laundry equipment is not built in, so enforcement would be a guess based on assumed equipment. This eliminates a choice of equipment for the resident – some people prefer appliances with agitators. Both front and top loaders are expected to remain in common use for the consumer. A question was brought up about affordability between styles.

**Committee Reason:**

611.4-MAZZ.doc

<b>Report for 06-87– 2021</b>		
<i>Committee decision: AS</i>	<i>Committee Vote at Meeting: 15-12-4</i>	<i>Committee Vote on Ballot:</i>
REPORT OF HEARING:		



<b>Report for 06-87– 2021</b>		
Modification (if any):		
Committee Reason: The proposal was approved because it is difficult to reach laundry by a seated person in the bottom of the drum in top loading equipment. There were concerns that there would be an enforcement issue because laundry equipment is not built in, so enforcement would be a guess based on assumed equipment. This eliminates a choice of equipment for the resident – some people prefer appliances with agitators. Both front and top loaders are expected to remain in common use for the consumer. A question was brought up about affordability between styles.		
<b>PUBLIC COMMENT- FIRST DRAFT:</b>		
Proponent:		
Desired Action:		
Modification:		
Reason:		
<i>Committee decision: AS/AM/D</i>	<i>Committee Vote at Meeting:</i>	<i>Committee Vote on Ballot:</i>
<b>REPORT OF HEARING – FIRST DRAFT</b>		
Modification (if any):		
Committee Reason:		
<b>PUBLIC COMMENT- SECOND DRAFT:</b>		
Proponent:		
Desired Action:		
Modification:		
Reason:		
<i>Committee decision: AS/AM/D</i>	<i>Committee Vote at Meeting:</i>	<i>Committee Vote on Ballot:</i>
<b>FINAL ACTION:</b>		
Modification (if any):		
Committee Reason:		

**06-88 – 2021**  
**612.2**

**Proponent:** Marsha Mazz, United Spinal Association

**Revise as follows:**

**SECTION 612**  
**SAUNA AND STEAM ROOMS**

**612.2 Bench.** Where seating is provided in saunas and steam rooms, at least one bench shall comply with section 903. Doors shall not swing into the clear floor space located adjacent to the bench and required by Section 903.2.

**Exception:** Where the room is for individual use and a clear floor space complying with Section 305.3 is provided within the room beyond the arc of the door swing, the door shall not be required to comply with this section.

**REASON:** For whatever reason, readers often fail to connect the clear floor space referenced by this section to the space provided at the bench for transfer onto the bench. While this proposal likely will be ruled Editorial, we hope that the committee will consider this change for the sake of clarity.

Committee Action: As submitted 25-0-3

**REPORT OF HEARING:**

**Modification (if any):**

**Committee Reason:** This proposal is a clarification of the requirements. This allows for the wheelchair to be in place for the transfer from the bench and still get the door open as part of entering or leaving the room.

**612.2-MAZZ.doc**

<b>Report for 06-88– 2021</b>		
<i>Committee decision: AS</i>	<i>Committee Vote at Meeting: 25-0-3</i>	<i>Committee Vote on Ballot:</i>
<b>REPORT OF HEARING:</b>		
Modification (if any):		
Committee Reason: This proposal is a clarification of the requirements. This allows for the wheelchair to be in place for the transfer from the bench and still get the door open as part of entering or leaving the room.		
<b>PUBLIC COMMENT- FIRST DRAFT:</b>		
Proponent:		
Desired Action:		
Modification:		
Reason:		
<i>Committee decision: AS/AM/D</i>	<i>Committee Vote at Meeting:</i>	<i>Committee Vote on Ballot:</i>
<b>REPORT OF HEARING – FIRST DRAFT</b>		
Modification (if any):		

<b>Report for 06-88- 2021</b>		
Committee Reason:		
<b>PUBLIC COMMENT- SECOND DRAFT:</b>		
Proponent:		
Desired Action:		
Modification:		
Reason:		
<b>Committee decision: AS/AM/D</b>	<b>Committee Vote at Meeting:</b>	<b>Committee Vote on Ballot:</b>
<b>FINAL ACTION:</b>		
Modification (if any):		
Committee Reason:		

## 06-89 – 2021 613(New)

**Proponent:** Marsha Mazz, United Spinal Association

**Add new text as follows:**

### **SECTION 613** **PET WASH STATION**

**613.1 Pet wash stations.** Where provided for pet washing and grooming, sinks and tubs shall comply with Section 613.

**613.1 Sinks.** Sinks shall comply with Section 606.

**613.2 Grooming Tubs.** Grooming tubs shall provide clear floor space positioned for a forward or parallel approach complying with Section 305.

**613.3 Operable parts.** Operable parts of sinks, tubs, and at least one of each type of associated accessories shall comply with Sections 308 and 309.

**EXCEPTION:** Drain stoppers and debris filters shall not be required to comply with Section 613.3.

---

**REASON:** Pet washing stations have become ubiquitous in modern condo and apartment buildings as well as in community centers. Where applicable, the Design and Construction Requirements of the Federal Fair Housing Amendments Act require “common use” spaces to be accessible to individuals with disabilities (24 CFR part 100.205(c)(1)). Without measurable standards, pet wash stations will always be a point of contention and the level of accessibility required by enforcement officials and expected by potential litigants will vary widely.

Our proposed accessibility criteria are simple. By requiring operable parts to be accessible, we believe that the height of the tub wall will be controlled by the requirements for a reach over an obstruction. We have exempted those items that would normally be on the floor of the tub such as drain stoppers and filters for hair and other debris. Where accessories such as shampoo dispensers, hair dryers, and hooks for leashes are provided, we have asked for only one of each type to be accessible. We have carefully research product literature to ensure that multiple manufacturers provide compliant products.

Links to some product literature:

- <https://www.groomersbest.com/product-category/bathing-tubs/ada-compliant/>
- <https://www.dog-on-it-parks.com/ada-elite-pet-wash-station.html>
- [https://www.directanimal.com/product/grooming/grooming-tubs/?utm\\_source=mv&utm\\_medium=paid&utm\\_campaign=intent&gclid=Cj0KCQjwjPaCBhDkARIsAISZN7S3QaIYngbxU4XhrGyXmoTkQscW2DaVNTcd13LxfiqCtQy8kb7A25QaAh0SEALw\\_wcB](https://www.directanimal.com/product/grooming/grooming-tubs/?utm_source=mv&utm_medium=paid&utm_campaign=intent&gclid=Cj0KCQjwjPaCBhDkARIsAISZN7S3QaIYngbxU4XhrGyXmoTkQscW2DaVNTcd13LxfiqCtQy8kb7A25QaAh0SEALw_wcB)

---

## 06-89 – 2021 Modification

613(New)

**Proponent:** Kimberly Paarlberg, ICC

**Further revise as follows:**

### SECTION 613 PET WASHING STATION

**613.1 Pet washing stations.** Where provided for pet washing ~~and grooming, sinks and tubs~~ pet washing stations shall comply with Section 613.

~~613.1 Sinks. Sinks shall comply with Section 606.~~

**613.2 Grooming Pet washing Tubs.** ~~Grooming~~ Pet washing tubs shall provide clear floor space positioned for a forward or parallel approach complying with Section 305.

**613.3 Operable parts.** The operable parts of the controls for on/ and off water flow, temperature, and diverter ~~sinks, tubs, and at least one of each type of associated accessories~~ shall comply with Sections ~~308 and~~ 309. Where a hand shower is provided, a mount to hold the hand shower shall be located in compliance with Section 308.

~~**EXCEPTION:** Drain stoppers and debris filters shall not be required to comply with Section 613.3.~~

**Reason:** The devices referenced in Masha’s reason statement could be considered a sink (because it has a drain). Since not all are raised, this could be interpreted as a shower. I have included a couple of examples below. These self wash stations are showing up in pet supply stores, apartment buildings and with car washes.

I find the current proposal confusing. If you make this be a required front approach by the reference to Section 606, the pan could be not deep enough to bath the dog, and the higher height makes harder for the dog to get up into the tub. You also need this station at a height that works for standing persons washing their dogs since there may be only one. Also, some people will interpret that ‘grooming’ is different than ‘bathing’. For example, when I take my dog to be groomed, it is getting his hair cut and his nails trimmed. (If there is a grooming counter in the room, that is a work counter and is addressed elsewhere.) I am not clear on what “associated accessories” would include (steps or ramps under the counter, a hook on the back wall to attach a lead, a shelf to hold towels), so this is too open for interpretation.

I am suggesting to delete the reference to sinks and just specifically address the pet washing station so we cover all types of pet washing stations. The revisions to Section 613.3 are for

consistency with the language the committee approved for tubs and showers. A referenced for 309 sends you back to 308 for reach range, so you do not need that for faucets, but you would need it for the fixed mount.

Alternatively, we can consider this addressed with the approval of 06-35-21 (for deep sinks to have a side approach) and we do not need any of this.







**Committee Action:** As modified 25-0-3

**REPORT OF HEARING:**

**Modification (if any):**

**Further revise as follows:**

**SECTION 613  
PET WASHING STATION**

**613.1 Pet washing stations.** Where provided for pet washing ~~and grooming, sinks and tubs~~ pet washing stations shall comply with Section 613.

~~**613.1 Sinks.** Sinks shall comply with Section 606.~~

~~**613.2 Grooming Pet washing Tubs.** Grooming~~ Pet washing tubs shall provide clear floor space positioned for a forward or parallel approach complying with Section 305.

**613.3 Operable parts.** The operable parts of the controls for on/ and off water flow, temperature, and diverter ~~sinks, tubs, and at least one of each type of associated accessories~~ shall comply with Sections ~~308 and~~ 309. Where a hand shower is provided, a mount to hold the hand shower shall be located in compliance with Section 308.

~~**EXCEPTION:** Drain stoppers and debris filters shall not be required to comply with Section 613.3.~~

**Committee Reason:** The modification puts in specific criteria for pet washing stations instead of using the current criteria for a sink or work counter. These spaces need to be accessible for



people taking care of their service or comfort animals, but must also work for standing persons using the same pet washing station.

**613.1(NEW)-MAZZ.doc**

<b>Report for 06-89- 2021</b>		
<b>Committee decision: AM</b>	<b>Committee Vote at Meeting: 25-0-3</b>	<b>Committee Vote on Ballot:</b>
<b>REPORT OF HEARING:</b>		
Modification (if any):		
<b>Further revise as follows:</b>		
<b>SECTION 613</b> <b>PET WASHING STATION</b>		
<b>613.1 Pet washing stations.</b> Where provided for pet washing and grooming, sinks and tubs <u>pet washing stations</u> shall comply with Section 613.		
<b>613.1 Sinks.</b> Sinks shall comply with Section 606.		
<b>613.2 Grooming Pet washing Tubs.</b> Grooming <u>Pet washing</u> tubs shall provide clear floor space positioned for a forward or parallel approach complying with Section 305.		
<b>613.3 Operable parts.</b> The operable parts of the controls for on/ and off water flow, temperature, and diverter sinks, tubs, and at least one of each type of associated accessories shall comply with Sections 308 and 309. <u>Where a hand shower is provided, a mount to hold the hand shower shall be located in compliance with Section 308.</u>		
<b>EXCEPTION:</b> Drain stoppers and debris filters shall not be required to comply with Section 613.3.		
Committee Reason: The modification puts in specific criteria for pet washing stations instead of using the current criteria for a sink or work counter. These spaces need to be accessible for people taking care of their service or comfort animals, but must also work for standing persons using the same pet washing station.		
<b>PUBLIC COMMENT- FIRST DRAFT:</b>		
Proponent:		
Desired Action:		
Modification:		
Reason:		
<b>Committee decision: AS/AM/D</b>	<b>Committee Vote at Meeting:</b>	<b>Committee Vote on Ballot:</b>
<b>REPORT OF HEARING – FIRST DRAFT</b>		
Modification (if any):		
Committee Reason:		
<b>PUBLIC COMMENT- SECOND DRAFT:</b>		
Proponent:		
Desired Action:		
Modification:		
Reason:		
<b>Committee decision: AS/AM/D</b>	<b>Committee Vote at Meeting:</b>	<b>Committee Vote on Ballot:</b>
<b>FINAL ACTION:</b>		
Modification (if any):		
Committee Reason:		

## **06-90 – 2021**

**106.2.2(New), 106.2.4(New), 106.2.5(New), 613(New)**

**Proponent:** Laurel Wright, representing the Adult Changing Facilities work group

**Add new text as follows:**

**106.2.2 Assistive products for personal hygiene (APPH) that support users – Requirements and test methods.** ISO/FDIS 17966: 2016(E) (International Organization for Standardization, Chemin de Blandonnet 8, CP 401, 1214 Vernier, Geneva, Switzerland)

**106.2.4 Medical Electrical Equipment - Part 1: General requirements for basic safety and essential performance – IEC 60601-1: 3.2 edition August 2020: International Electrotechnical Commission (IEC) 3 rue de Varembe, PO Box 131, CH-1211 Geneva, Switzerland.**

**106.2.5 Medical electrical equipment - Part 1-2: General requirements for basic safety and essential performance - Collateral Standard: Electromagnetic disturbances - Requirements and tests: 60601-1-2:2014 + ADM1: 2020 CVS: International Electrotechnical Commission (IEC) 3 rue de Varembe, PO Box 131, CH-1211 Geneva, Switzerland.**

### **SECTION 613** **ADULT CHANGING STATIONS**

**613.1 General.** Adult changing stations shall comply with Section 613.2 through 613.4.

**613.2 Safety and performance.** Adult changing stations shall comply with the following standards:

1. ISO 17966 Sections: 5 Materials; 7 Electromagnetic compatibility; 8 Electrical safety; 11 Safety of moving and folding parts; 11.2 Prevention of traps for parts of human body; 16 Static strength, impact, durability; 17 Stability listed in Section 106.2.2.
2. IEC 60601-1 listed in Section 106.2.4.
3. IEC 60601-1-2 listed in Section 106.2.5.

**613.3 Changing surface.** A changing surface shall be provided and shall comply with Section 613.3.

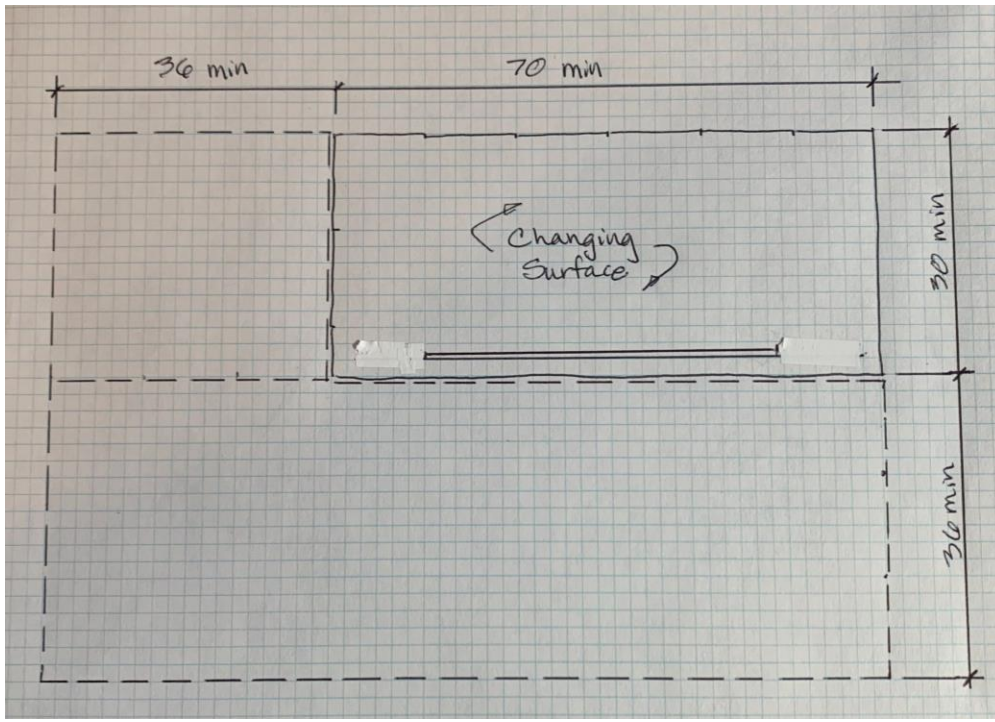
**613.3.1 Size.** The changing surface shall be 70 inches (1778mm) minimum in length and 30 inches (762mm) minimum in width.

**613.3.2 Clearances.** Clearances complying with Sections 613.3.2.1 and 613.3.2.2 shall be provided adjacent to the changing surface, measured when the surface is in the operational position.

**613.3.2.1 Side clearance.** A 36 inch (914mm) deep minimum clearance shall be provided along the length of one long side of the changing surface and shall extend 36 inches (914mm) minimum past the surface on at least one end.

**613.3.2.2 End clearance.** A 36 inch (914mm) deep minimum clearance shall be provided on at least one end of the changing surface and shall extend the width of the changing surface.

**Exception:** A 24 inch (610 mm) deep minimum clearance shall be permitted on at least one end of the changing surface where a clear floor space complying with Section 305.3 is provided within the room outside the clearances for the changing surface.



**Figure 613.3.2**  
**Changing surface and clearances**

**613.3.3 Height adjustability.** The changing surface height shall be continuously adjustable from 17 inches (432mm) minimum to 38 inches (965mm) maximum above the floor as measured to the top of the changing surface.

**Exception:** Where approved by the authority having jurisdiction, a fixed height changing surface shall be permitted and shall be mounted with the top of the changing surface 17 inches (432mm) minimum and 19 inches (483mm) maximum above the floor.

**613.3.3.1 Operation.** Operable controls for height adjustment and, where provided, on and off shall comply with Section 309.4.

**613.3.4 Capacity.** Allowable stresses for materials, fastening mounting devices, and support structure shall support a downward force of not less than 350 lbs. (159 kg) applied to any point on the changing surface.

**613.3.5 Changing surface.** The changing surface shall be comprised of non-porous and durable materials.

**613.3.6 Side rail.** Side rails shall be provided at the changing surface in accordance with Sections 613.3.6.1 and 613.3.6.2.

**613.3.6.1 Size and location.** Side rails shall be a minimum of 2/3 of the length of the changing surface and shall be centered +/- 1 inch (25mm) along the long open sides of the changing surface.

**Exception.** A side rail shall not be required on the long side opposite the side clearance required by Section 613.3.2.1, provided that side abuts a wall or is otherwise protected.

**613.3.6.2 Rail positioning.** Side rails shall be capable of being raised and lowered and, when in the raised position, shall lock in place. The top of the side rail shall extend 5 inches (127mm) minimum above the top of the changing surface. When in the lowered position, the rail shall not obstruct transfer to or from the changing surface.

**613.4 Installation location.** Where provided, adult changing stations shall be installed in accordance with the locations specified in Section 613.4.1, 613.4.2 or 613.4.3.

**Exception:** Where installed in locations specified in Section 613.4.3, side and end clearances compliance with Section 613.3.2 are not required.

**613.4.1. Single user or family or assisted use toilet or bathing room.** Where adult changing stations are provided in a toilet room with only one water closet and one lavatory, or in a family or assisted-use toilet or bathing room, the room shall provide all of the following components:

1. A dispenser for soap complying with Section 308.
2. A hand towel dispenser or hand dryer complying with Table 603.6.
3. A coat hook located in close proximity to the changing surface.
4. A waste receptacle.
5. Signage indicating “Adult Changing Station” provided at the entrance to the room and complying with the visual character requirements in Section 703.2.

**613.4.2 Multi-user toilet or bathing room.** Where adult changing stations are provided in a multi-user toilet or bathing room, the adult changing station shall be located in a compartment that includes all of the following components:

1. Privacy provided by walls, curtains or partitions enclosing the compartment.
2. A turning space complying with Section 304.
3. A lavatory complying with Section 606.
4. A dispenser for soap complying with Section 308.
5. A hand towel dispenser or hand dryer complying with Table 603.6.
6. A coat hook in close proximity to the changing surface.
7. A waste receptacle.

8. Signage indicating “Adult Changing Station” provided at the entrance to the room and complying with the visual character requirements in Section 703.2.

**613.4.3 Room or space other than a toilet room.** Where adult changing stations are provided in a room or space other than a toilet or bathing room and including, but not limited to, nurses’ work areas, therapist work areas, or special education classrooms, the adult changing station shall be located in a compartment or room that includes all of the following components:

1. Privacy provided by walls, curtains or partitions.
2. A turning space complying with Section 304.
3. A lavatory complying with Section 606 or an alcohol-based hand sanitizer dispenser.
4. Where a lavatory is provided in the compartment or room, provide a dispenser for soap.
5. Where a lavatory is provided in the compartment or room, provide a hand towel dispenser or hand dryer complying with Table 603.6.
6. A waste receptacle.

**613.5 Clearances.** An adult changing station and its supporting structure shall not obstruct required clear floor spaces and clearances at accessible elements, maneuvering clearances at doors, or the wheelchair turning spaces.

---

**REASON:** The purpose of this standard proposal is to develop criteria for adult changing tables and the rooms in which they are installed. This is intended to coordinate with scoping provisions provided to the I-codes in proposals E141-21(AMPC1), E142-21(AMPC 1 and 2), P37-21(AMPC1) and M20-21(AS). This proposal is a result of the meetings held by the Adult Changing Facilities work group set up by the ICC A117.1 committee. The work group met every two weeks to develop this criteria. Participation included work group members and interested parties with a wide range of interests, and included representatives of manufactures of adult changing tables and parents of adult persons with disabilities that need to use adult changing tables. The work group reviewed eighteen proposed state laws, two already adopted, and four guidelines in European, Australian and North American countries for adult changing tables. While there is interest in many states to provide such facilities, investigations by this work group showed either no technical guidance or very inconsistent information and application. The end result currently is limiting access to children with disabilities who have grown up with accessibility in schools and public places since the ADA went into effect, as well as disenabling a significant number of adults with disabilities who have experienced a different type of life-changing event, accidents, injuries or wars.

The following is an impact statement on the benefits of having these facilities in buildings and facilities.

- Limiting access to those who need adult changing stations decreases the community size dramatically. Nationally, the Centers for Disease Control and Prevention (CDC) reports 61 Million adults (26% of the US population) have some form of disability, with 24.1%

affected in the areas of mobility, independent living, and self care. Further, each of those folks need assistance, and likely travel with additional family members. Once this population is taken out of the community, businesses are also losing a large potential of support and income. Providing our citizens more opportunities to participate in the community and patronize local establishments strengthens communities, allowing all family members to engage or travel together as one family nucleus. Currently many families have to make the choice to participate in activities outside of the home with only a portion of their family.

- Individually, families from many states are pushing for the adult changing facilities. A national campaign, Changing Spaces, has been activated, with chapters in at least 10 states, advocating for height adjustable changing tables to be required in public places. At least 12 states have proponents actively proposing and working toward legislation, while as many as 18 states have draft language in play. California has already enacted legislation requiring adult changing stations. Maryland has legislation that goes into effect next year. Accepting this proposal will show wide-spread acceptance of the need along with a consistent set of standards across the country for users to rely on.
- We are all part of an aging population and the elderly still want to be able to attend family gatherings and travel in a car to be with relatives. These adult changing facilities would be valued not only by families with adult disabled children but also be aging adult family members.
- Without appropriate changing facilities, families cannot travel more than 30-40 miles from home. Additionally, trips that involve more than a few hours of time are also a risk. As a result, vacations, trips to zoos, aquariums, museums, concerts, and similar events are eliminated.
- The addition of adult changing tables will present a tremendous change in the quality of life for so many people who were unable to get out and participate in many activities before due to the lack of adequate facilities.

The following are reasons for the portions of the proposal dealing with the adult changing table/surface:

The work group compared the recommended changing surface technical requirements with changing tables on the market and verified that the requirements recommended are available from multiple sources. The following are specific to the sections for the changing surface.

### **613.2 Safety and performance.**

Adult changing stations shall comply with the following:

- 1) ISO 17966 Sections: 5 Materials; 7 Electromagnetic compatibility; 8 Electrical safety; 11 Safety of moving and folding parts; 11.2 Prevention of traps for parts of human body; 16 Static strength, impact, durability; 17 Stability;
- 2) IEC 60601-1 Medical electrical equipment – Part 1: General requirements for basic safety and essential performance; and
- 3) IEC 60601-1-2 Collateral Standard: Electromagnetic disturbances.

These standards were referenced because compliance assures changing station' design and operation will provide electrical and mechanical safety, structural strength, durability, safety of



moving parts, prevent entrapment of human body parts and side rail safety for people with disabilities and their caregivers.

### **613.3.1 Size.**

ICC A117.1 has requirements for benches to change clothes with a depth of 24” (Section 903.3). The 30” minimum width is thought to be most appropriate for a person laying down. The 70” length is based on the average height of an adult male.

#### **613.3.2.1 Side clearance.**

A 36” deep minimum side clearance along the length of one long open side allows for an accessible route with space to park a wheelchair to support transfer to/from changing surface.

#### **613.2.2.2 End clearance.**

A 36” deep minimum clearance on at least one end of the changing surface allows space for individual to move around the table to manipulate clothing and change the individual. It also allows for the wheelchair to be located at that end while a care giver is changing someone. The exception would allow for a 24” clearance at the end (based on information from Assisted Toileting and Bathing work group and study from the Rothchild’s Foundation) if there was another location in the room to move the wheelchair. (The California Code requires 36” deep minimum clearance on both ends of the changing surface.)

### **613.3.3 Height adjustability.**

The 17” lowest height is consistent with the ADA 17” to 19” water closet seat height requirement. The average height of a wheelchair seat is 19” above the floor. Lateral transfer to 17” changing surface height is practical. Adjustable height range is consistent with eight states’ (FL, NH, OK, WI, CA, MN, IA, MI) published height requirements.

The exception allows a fixed height surface. Fixed height changing surface is: (1) better than no changing surface; (2) a solution for vandalism of adjustable height adult changing surface.

#### **613.3.3.1 Operation.**

Controls of height adjustment comply with ADA Section 309.4 since operation is by the care giver, not the person on the table. Raising and lowering folding changing surface and side rails are not covered by ADA Section 309.4

### **613.3.4 Capacity.**

“Not less than 350 lbs.” was selected as changing surface capacity because it covers 99% of the general population. Six states (FL, IL, MN, NH, OK and WI) of ten listing load capacity, state 350 lbs. One state (CA) of ten listing load capacity, states 300 lbs. Four states (IA, MI, ND and OH) of ten listing load capacity, state 440 lbs.

CDC data for body weight for the time period 2015-2018 indicates the following. For adult males age 20 and over, the data for all males examined (n=5,085) indicated a mean body weight of 199.8 lbs., and a body weight of 287.2 lbs. at the 95<sup>th</sup> percentile. When this data is analyzed by age range, body weight at 95<sup>th</sup> percentile ranged from 238.0 lbs. for males 80 years and over to 308.5 lbs. for males 30 -39 years of age.

One private sector website offers a body weight percentile calculator, based on the CDC's 2015-2016 NHANES survey. The site specifies that the 99<sup>th</sup> percentile for adult males as being 341.1 lbs.

Specification of capacity at 350 lbs. seems reasonable, to account for clothing and any supplies that need to be available during the changing activity. Additionally, the 350 lbs. capacity offers a factor of safety of 1.21 when applied to the 287.5 lbs., 95<sup>th</sup> percentile figure, and 1.02 when applied to the 341.1 lbs., 99<sup>th</sup> percentile figure.

*Anthropometric Reference Data for Children and Adults: United States, 2015-2018. Analytical and Epidemiological Studies. U.S. Department of Health and Human Services, Centers for Disease Control and Prevention, National Center for Health Statistics.*

*National Health and Nutrition Examination Survey, NHANES 2015-2016. U.S. Department of Health and Human Services, Centers for Disease Control and Prevention cited on website <https://dqydj.com/weight-percentile-calculator-men-women/#:~:text=At%20the%20lowest%20extremes%20for%20adults%2C%20the%201st,for%20men.%20Weight%20alone%20doesn't%20tell%20you%20enough>.*

**613.3.5 Changing surface.** The surface shall be non-porous surface for easy, thorough cleaning. Surface shall be durable to provide multiple years of service under normal conditions of use.

**613.3.6.1 Side rail, size and location.**

Relate side rail length to changing surface length without referring to a specific inch dimension. Allows for shorter length changing surfaces and rails.

**613.3.6.2 Side rail positioning.**

A side rail is needed on open side of changing surface to prevent person being cared for from rolling off. The 5" minimum height from the top of the side rail to the changing surface is considered a practical height for the caregiver to lean over.

The following are reasons for the portions of the proposal dealing with the room where the adult changing table/surface is located:

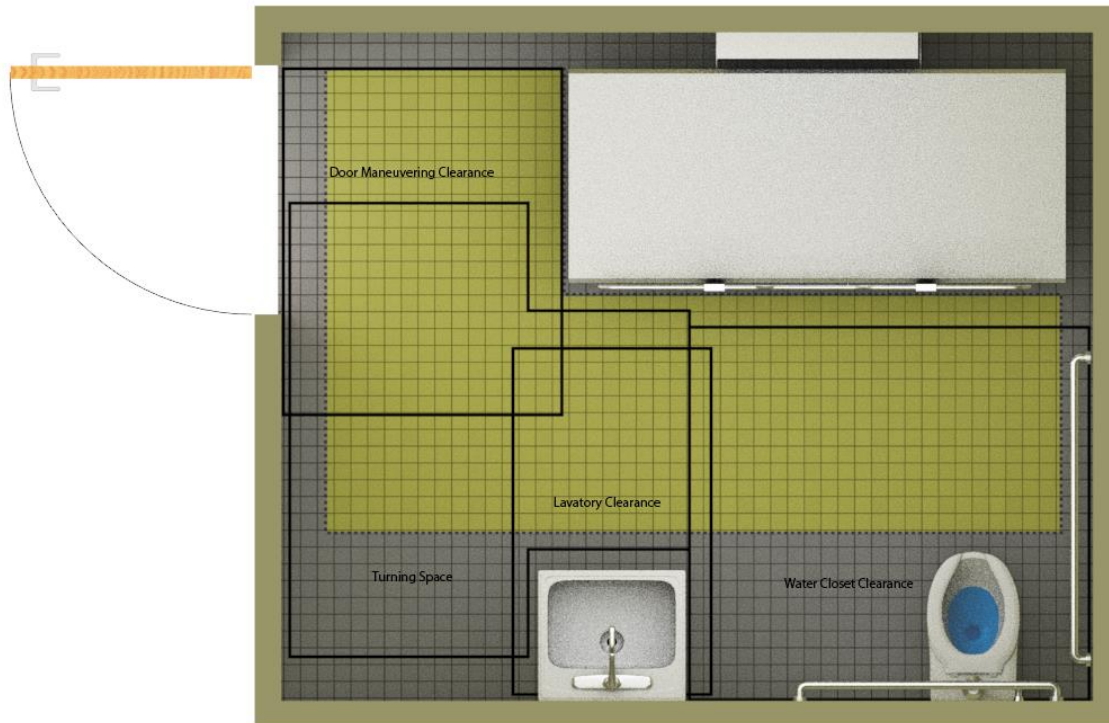
**613.4 Installation location.**

There currently is no existing technical design criteria for this feature. A need for adult changing facilities has been brought forth in proposed bills in multiple states with differing sets of design criteria. The proposed bills' criteria were reviewed when developing these recommendations to provide a consistent set of technical criteria that meets the minimum needs of care providers for a private changing facility to change the adults with disabilities whom they care for, while at the same time maintaining required clearances at other fixtures in the room.

Consideration was given to the size of the changing surface being recommended by the Table sub-group to ensure that when in the open position, the changing surface does not obstruct the required clearances for toilets, sinks, doors and maneuvering when an adult changing surface is provided. It is necessary to ensure that the adult changing surface does not create a barrier for



other persons with disabilities who may come to use the toilet room if the changing surface is folding and left in the open position. In addition to maintaining required clear floor spaces at other fixtures in the room, it was determined that the changing surface could not overlap the room's turning space because some tables have a base underneath that does not allow for open knee and toe clearance that could otherwise be utilized as part of a turning space.



**Staff note:** The new standards will be provided for the ICC A117.1 committee members to review. The standards are copyrighted, so this will only be available for the committee and in a read only format.

## 06-90 – 2021 Replacement proposal

603.2.2, 613(New), 902.1

**Proponent:** Laurel Wright, representing the Adult Changing Facilities work group

**Replace and revise as follows:**

**603.2.2 Door swing.** Doors shall not swing into the clear floor space or clearance for any fixture.

**EXCEPTIONS:**

1. Doors to a toilet or bathing room for a single occupant, accessed only through a private office and not for common use or public use shall be permitted to swing into the clear floor space, provided the swing of the door can be reversed to comply with Section 603.2.2.

2. Where the room is intended for individual use, family or assisted-use, and a clear floor space is provided within the room outside the arc of ~~the~~ a door swing, ~~the~~ such a door shall not be required to comply with 603.2.2.

## **SECTION 902**

### **DINING SURFACES AND WORK SURFACES**

**902.1 General.** Accessible dining surfaces and work surfaces shall comply with Section 902.

#### **Exceptions:**

1. Dining surfaces and work surfaces primarily for children's use shall be permitted to comply with Section 902.5.
2. Adult changing surfaces shall not be required to comply this section.

## **SECTION 613**

### **ADULT CHANGING STATIONS**

**613.1 General.** Adult changing stations shall comply with Section 613.2 through 613.4.

**613.2 Installation location.** Where provided, adult changing stations shall be installed in accordance with the locations specified in Section 613.2.1, 613.2.2 or 613.2.3.

**613.2.1. Single user or family or assisted use toilet or bathing room.** Where adult changing stations are provided in a toilet room with only one water closet and one lavatory, or in a family or assisted-use toilet or bathing room, the room shall provide all of the following components:

6. A dispenser for soap complying with Section 308.
7. A hand towel dispenser or hand dryer complying with Table 603.6.
8. A coat hook located in close proximity to the changing surface.
9. A waste receptacle.
10. Signage indicating "Adult Changing Station" provided at the entrance to the room and complying with the visual character requirements in Section 703.2.
11. Signage indicating the weight capacity and instructions for operation of the changing station within the room.

**613.2.2 Multi-user toilet or bathing room.** Where adult changing stations are provided in a multi-user toilet or bathing room, the adult changing station shall be located in a compartment that includes all of the following components:

1. Privacy provided by walls, curtains or partitions enclosing the compartment.
2. A turning space complying with Section 304.
3. A lavatory complying with Section 606.
4. A dispenser for soap complying with Section 308.
5. A hand towel dispenser or hand dryer complying with Table 603.6.
6. A coat hook in close proximity to the changing surface.
7. A waste receptacle.
8. Signage indicating "Adult Changing Station" provided at the entrance to the room and complying with the visual character requirements in Section 703.2.

9. Signage indicating the weight capacity and instructions for operation of the changing station within the compartment.

**613.2.3 Room or space other than a toilet room or bathing room.** Where adult changing stations are provided in a room or space other than a toilet or bathing room and including, but not limited to, nurses' work areas, therapist work areas, or special education classrooms, the adult changing station shall be located in a compartment or room that includes all of the following components:

7. Privacy provided by walls, curtains or partitions.
8. A turning space complying with Section 304.
9. A lavatory complying with Section 606 or an alcohol-based hand sanitizer dispenser.
10. Where a lavatory is provided in the compartment or room, provide a dispenser for soap.
11. Where a lavatory is provided in the compartment or room, provide a hand towel dispenser or hand dryer complying with Table 603.6.
12. A waste receptacle.
13. Signage indicating the weight capacity and instructions for operation of the changing station within the room.

**613.3 Room clearances.** An adult changing station and its supporting structure shall not obstruct required clear floor spaces and clearances at accessible elements, maneuvering clearances at doors, or the wheelchair turning spaces.

**613.4 Changing surface.** A changing surface shall be provided and shall comply with Section 613.4.

**613.4.1 Safety and performance.** Adult changing stations shall comply with the following safety and performance requirements:

1. Protect the user from falling from the changing surface along the open long sides, by means such as retractable safety rails.
2. Provide a belt to secure the user on the changing surface.
3. Protect the user and caregiver from entrapment during operation.
4. Support a weight of not less than 400 lbs. (182 kg) applied to the changing surface
5. Provide a method to prevent tipping such as secured to the floor or wall, or other means.
6. Provide a changing surface that is durable, cleanable, non-absorbent, and resistant to corrosion.
7. Electrical components complying with NFPA 70.
8. Operable controls for height adjustment and, where provided, on and off complying with Section 309.4.

**613.4.2 Size.** The changing surface shall be 70 inches (1778mm) minimum in length and 30 inches (762mm) minimum in width.

**613.4.3 Height adjustability.** The changing surface height shall be adjustable at variable heights from 17 inches (432mm) minimum to 38 inches (965mm) maximum above the floor as measured to the top of the changing surface.

**Exception:** Where the adult changing station is not required by the administrative authority, a fixed height changing surface shall be permitted and shall be mounted with the top of the changing surface 19 inches (483mm) minimum and 23 inches (584 mm) maximum above the floor.

**613.4.4 Clearances.** Clearances complying with Sections 613.4.4.1 and 613.4.4.2 shall be provided adjacent to the changing surface, measured when the surface are in the operational position.

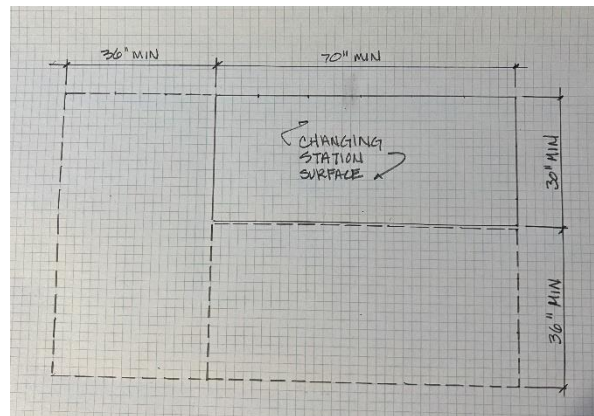
**613.4.4.1 Side clearance.** A 36-inch (914mm) deep minimum side clearance shall be provided along the open long side of the changing surface.

**Exception:** In the raised position, the side rail shall be permitted to overlap the side clearance.

**613.4.4.2 End clearance.** A 36-inch (914mm) wide minimum end clearance shall be provided along the depth of one end of the changing surface. The width of the end clearance shall extend the depth of the changing surface and the side clearance.

**Exceptions:**

1. A 24-inch (610 mm) wide minimum end clearance shall be permitted where a clear floor space complying with Section 305.3 is provided within the room beyond the clearances for the changing surface.
2. Where installed in locations specified in Section 613.2.3, end clearances complying with Section 613.4.4.2 is not required.



**Figure 613.4.4**  
**Changing surface and clearances**

**613.4.5 Side rail.** Where side rails are provided at the changing surface they shall comply with Sections 613.4.5.1 and 613.4.5.2.

**613.4.5.1 Size and location.** Side rails shall be a minimum of 2/3 of the length of the changing surface and shall be centered +/- 3 inch (75 mm) along the long open sides of the changing surface.

**613.4.5.2 Rail positioning.** Side rails shall be capable of being raised and lowered. The side rail shall be fixed in place when in the raised position. The top of the side rail shall extend 5 inches (127mm) minimum above the top of the changing surface.

**REASON:** The purpose of this standard proposal is to develop criteria for adult changing tables and the rooms in which they are installed. This is intended to coordinate with scoping provisions provided to the I-codes in proposals E141-21(AMPC1), E142-21(AMPC 1 and 2), P37-21(AMPC1) and M20-21(AS). This proposal is a result of the meetings held by the Adult Changing Facilities work group set up by the ICC A117.1 committee. The work group met from August 2020 to December of 2021 to develop this criteria. They have met several times in 2022 to improve the proposal based on comments from the full A117.1 committee.

Participation included work group members and interested parties with a wide range of interests, and included representatives of manufacturers of adult changing tables and parents of adult persons with disabilities that need to use adult changing tables. The work group reviewed eighteen proposed state laws, two already adopted, and four guidelines in European, Australian and North American countries for adult changing tables. While there is interest in many states to provide such facilities, investigations by this work group showed either no technical guidance or very inconsistent information and application. The end result currently is limiting access to children with disabilities who have grown up with accessibility in schools and public places since the ADA went into effect, as well as disenabling a significant number of adults with disabilities who have experienced a different type of life-changing event, accidents, injuries or wars.

The following is an impact statement on the benefits of having these facilities in buildings and facilities.

- Limiting access to those who need adult changing stations decreases the community size dramatically. Nationally, the Centers for Disease Control and Prevention (CDC) reports 61 Million adults (26% of the US population) have some form of disability, with 24.1% affected in the areas of mobility, independent living, and self care. Further, each of those folks need assistance, and likely travel with additional family members. Once this population is taken out of the community, businesses are also losing a large potential of support and income. Providing our citizens more opportunities to participate in the community and patronize local establishments strengthens communities, allowing all family members to engage or travel together as one family nucleus. Currently many

families have to make the choice to participate in activities outside of the home with only a portion of their family.

- Individually, families from many states are pushing for the adult changing facilities. A national campaign, Changing Spaces, has been activated, with chapters in at least 10 states, advocating for height adjustable changing tables to be required in public places. At least 12 states have proponents actively proposing and working toward legislation, while as many as 18 states have draft language in play. California has already enacted legislation requiring adult changing stations. Maryland has legislation that goes into effect next year. Accepting this proposal will show wide-spread acceptance of the need along with a consistent set of standards across the country for users to rely on.
- We are all part of an aging population and the elderly still want to be able to attend family gatherings and travel in a car to be with relatives. These adult changing facilities would be valued not only by families with adult disabled children but also be aging adult family members.
- Without appropriate changing facilities, families cannot travel more than 30-40 miles from home. Additionally, trips that involve more than a few hours of time are also a risk. As a result, vacations, trips to zoos, aquariums, museums, concerts, and similar events are eliminated.
- The addition of adult changing tables will present a tremendous change in the quality of life for so many people who were unable to get out and participate in many activities before due to the lack of adequate facilities.

The following are reasons for the portions of the proposal dealing with the adult changing table/surface:

The work group compared the recommended changing surface technical requirements with changing tables on the market and verified that the requirements recommended are available from multiple sources. The following are specific to the sections for the changing surface.

**603.2.2 Door swing** (to family or assisted-use toilet room) – (see also 613.3) Similar to a single occupant bathroom, it is assumed that persons using this room will enter the room and lock the door. Therefore, the door can swing over clear floor spaces provided that the a wheelchair space is located past the swing of the door.

**902.1 General** (Work surface) – (see also 613.2) Some tables are wall mounted and could provide knee and toe clearances, however to achieve desired weight capacity and stability, there are many options with a center post or an x-brace system that need to be permitted. Therefore, adult changing surfaces, while a work surface for a care provider, is not also required to be an accessible work surface due to the potential lack of knee and toe clearances.

**613 Adult changing stations and 613.1 General** – This is a new section for the technical criteria for adult change stations. The IBC and the Appendix will include locations where these should be required for public access so that parents can change their adult children. For use and safety, these provisions will also apply where adult changing facilities are provided voluntarily.



There currently is no existing technical design criteria for adult changing facilities. A need for adult changing facilities has been brought forth in proposed bills in multiple states with differing sets of design criteria. The proposed bills' criteria were reviewed when developing these recommendations to provide a consistent set of technical criteria that meets the minimum needs of care providers for a private changing facility to change the adults with disabilities whom they care for, while at the same time maintaining required clearances at other fixtures in the room.

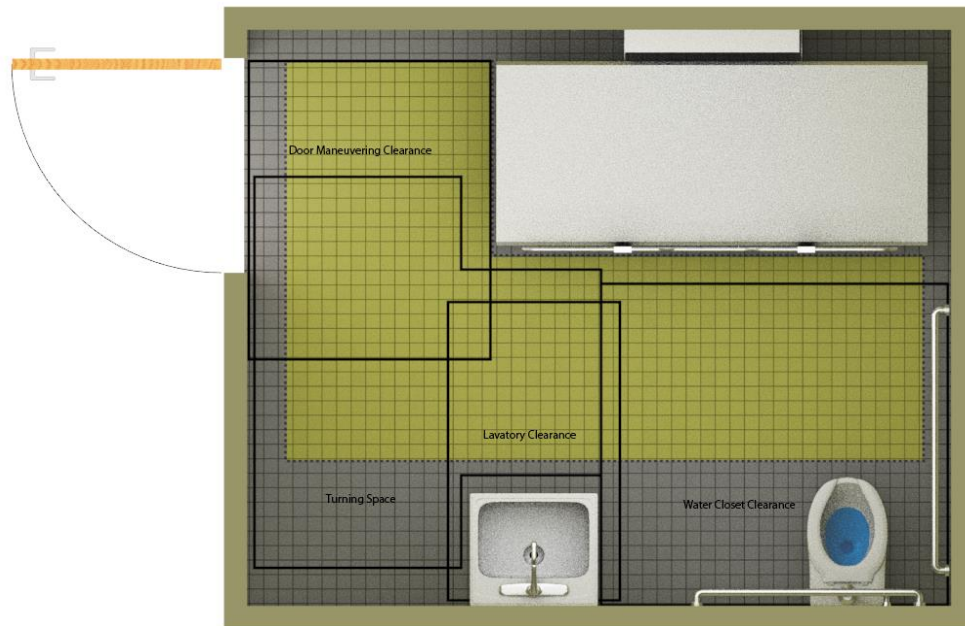
**613.1.2 Installation location** – Where adult changing facilities are required, they will be provided in a separate toilet room (613.2.1). Where provided, but not required, they can be in a separate toilet room (613.2.1, in a bathroom in a separate stall (613.2.2) or in a private area (613.2.3). The work group felt that that there should be additional allowances for locations where the persons with disabilities are cared for in areas such as special education classrooms or in school nurses' offices where the primary care giver is not family members. The intent is to allow the adult changing tables in the locations that best serves the situation where these are provided voluntarily.

**613.2.1. Single user or family or assisted use toilet or bathing room.** – In a private bathroom, to allow for sanitation of the table, the user and the care giver, along with the fixtures (lavatory, water closet), the room will include soap, towels and a garbage can. There will be a coat hook in the room. Signage outside to identify the room and instructions for the table operation inside the room are required.

**613.2.2 Multi-user toilet or bathing room.** Where a table is provided in a multi-stall bathroom, the table will be in a private area. Within that area will be a lavatory with soap and a hand dryer, or hand towel dispenser. A garbage can is required. Signage to identify the room outside and instructions for the table operation are required.

**613.2.3 Room or space other than a toilet room or bathing room.** These are primarily for, but not limited to, nurses' work areas, therapist work areas, or special education classrooms. Privacy is required. Within that area if the room has a lavatory, also provide soap and a hand dryer, or hand towel dispenser. There is the option for a hand sanitizer. A garbage can is required. Instructions for the table operation are required.

**613.3 Room clearances.** Consideration was given to the size of the changing surface being recommended by the Table sub-group to ensure that when in the open position, the changing surface does not obstruct the required clearances for toilets, sinks, doors and maneuvering when an adult changing surface is provided. It is necessary to ensure that the adult changing surface does not create a barrier for other persons with disabilities who may come to use the toilet room if the changing surface is folding and left in the open position. (A folding table is permitted, but the intent is that when the table is down, it will not be necessary to lift the table to access the other fixtures.) In addition to maintaining required clear floor spaces at other fixtures in the room, it was determined that the changing surface could not overlap the room's turning space because some tables have a base underneath that does not allow for open knee and toe clearance that could otherwise be utilized as part of a turning space.



**613.2 Safety and performance.** The committee has applied to work with IAPMO to develop a standard specific to adult changing. This list is the performance criteria to use for safety until this standard is finished.

Item 1 and 2 - Both a safety belt and a side rail will be required. The side rail prevents the user from rolling off the changing surface. The belt secures the user in place and, from the commentary received from Jennifer and other parents, is a necessary secondary item that prevents the user from rolling around on the surface. Not all users may require it, but from the comments received so far, having a belt to secure the user allows the caretaker to be more free in his/her movements/administrations during the changing process. Side rails are required by six states (FL, IA, IL, MI, MN, WI) and a safety belt is required in five states (FL, IA, IL, MI, MN) of the eleven states listing changing station requirements. A safety belt is included on four adult, adjustable height changing station models of the twelve products from six manufacturers the Adult Changing Station Task Force surveyed.

Item 3, 4 and 5– Consideration of possible entrapment, capacity and no tipping are important safety issues.

“Not less than 350 lbs.” was originally selected as changing surface capacity because it covers 99% of the general population. Six states (FL, IL, MN, NH, OK and WI) of ten listing load capacity, state 350 lbs. One state (CA) of ten listing load capacity, states 300 lbs. Four states (IA, MI, ND and OH) of ten listing load capacity, state 440 lbs.



One private sector website offers a body weight percentile calculator, based on the CDC’s 2015-2016 NHANES survey. The site specifies that the 99<sup>th</sup> percentile for adult males as being 341.1 lbs.

It is suggested that the weight capacity of the adult-size, adjustable height changing station should be “not less than 400 lbs. (182 kg)”. Commentary from parents of adult children who use adjustable height changing stations to change their children indicated that additional weight beyond the users’ weight is placed on the changing station surface. First, the care giver will apply pressure to the changing surface during the changing process. Second, the care giver may add equipment to the changing surface that is needed during the changing process. Third, the care giver may lie on the changing surface to calm down their agitated child while another caregiver performs the changing process. The weight capacities of twelve adult-size, adjustable height changing station models, from six manufacturers, on the market surveyed by the Adult Changing Station Task Force shows the following:

- Under 400 lbs., 2
- 400 lbs., 1
- 440 lbs., 8
- 500 lbs., 1

Item 6 – This is common language for surfaces that need to be cleanable for sanitation reasons. The surface shall be non-porous surface for easy, thorough cleaning. Surface shall be durable to provide multiple years of service under normal conditions of use.

Item 7 – NFPA 70 is the National Electrical Code and will reduce the chance of accidental shock.

Item 8 – the controls to operate the height of the table are for the caregiver and should be places where it is best to serve their needs for a smooth operation of the changing surface. This may not be on the side or over the table.

**613.4.2 Size.** ICC A117.1 has requirements for benches to change clothes with a depth of 24” (Section 903.3). The 30” minimum width is thought to be most appropriate for a person laying down. The 70” length is based on the average height of an adult male.

**613.4.3 Height adjustability.** The 17” lowest height is consistent with the ADA 17” to 19” water closet seat height requirement. The average height of a wheelchair seat is 19” above the floor. Lateral transfer to 17” changing surface height is practical. Adjustable height range is consistent with eight states’ (FL, NH, OK, WI, CA, MN, IA, MI) published height requirements. “Adjustable at variable heights” will allow for reasonable transitions.

Reasons for 38” Maximum Height Adjustability - The maximum height of twelve adult-size, adjustable height changing station models, from six manufacturers, on the market surveyed by the Adult Changing Station Task Force shows 9 of the 12 meet this height requirement.

The maximum height of states’ requirements surveyed shows the following:

38" (1) CA  
34" (7) FL, IA, MI, NH, OH, OK, WI  
28" (1) MN  
No height listed (5) GA, IL, PA, TX, VI

The 38" maximum adjustable height suggested is consistent with a majority of the adult-size, adjustable height changing station models on the market offering a higher maximum height than is stated in majority of U.S. States' requirements.

The exception allows a fixed height surface where tables are provided voluntarily. Fixed height changing surface is: (1) better than no changing surface; (2) a solution for vandalism of adjustable height adult changing surface; (3) a significant reduction in cost that should encourage additional tables where needed (such as in every special education classroom in a school). The 19" to 23" is based on new information for the Access Board about the range of wheelchair seat heights.

**613.4.4 Clearances.** Folding tables are not prohibited, so the clearance are required when the table is in its operational position.

**613.4.4.1 Side clearance.** A 36" deep minimum side clearance along the length of one long open side allows for an accessible route with space to park a wheelchair to support transfer to/from changing surface.

The exception allows for side rails to be inbound or outbound of the of the changing surface. When the side rails are down, they should not obstruct the transfer to the table.

**613.4.4.2 End clearance.** A 36" deep minimum clearance on at least one end of the changing surface allows space for caregiver to move around the table to manipulate clothing and change the user. It also allows for the wheelchair to be located at that end while a care giver is changing someone.

Exception 1 would allow for a 24" clearance at the end (based on information from Assisted Toileting and Bathing work group and study from the Rothchild's Foundation) if there is another location in the room to move the wheelchair. (The California Code requires 36" deep minimum clearance on both ends of the changing surface.)

Exception 2 allows for tables in nurses' work areas, therapist work areas, or special education classrooms to be located in an alcove where necessary.

#### **613.4.5 Side rail,**

**613.4.5.1 Size and location.** Relate side rail length to changing surface length without referring to a specific inch dimension.

**613.3.6.2 Side rail positioning.** A side rail is needed on open side of changing surface to prevent person being cared for from rolling off. The 5" minimum height from the top of the side rail to the changing surface is considered a practical height for the caregiver to lean over.

Committee Action: As Modified 26-0-0

**REPORT OF HEARING:**

**Modification (if any):** Motion to delete 613.4.1 passed 26-3-0

**Further revise as follows:**

~~**613.4.1 Safety and performance.** Adult changing stations shall comply with the following safety and performance requirements:~~

- ~~1. Protect the user from falling from the changing surface along the open long sides, by means such as retractable safety rails.~~
- ~~2. Provide a belt to secure the user on the changing surface.~~
- ~~3. Protect the user and caregiver from entrapment during operation.~~
- ~~4. Support a weight of not less than 400 lbs. (182 kg) applied to the changing surface~~
- ~~5. Provide a method to prevent tipping such as secured to the floor or wall, or other means.~~
- ~~6. Provide a changing surface that is durable, cleanable, non-absorbent, and resistant to corrosion.~~
- ~~7. Electrical components complying with NFPA 70.~~
- ~~8. Operable controls for height adjustment and, where provided, on and off complying with Section 309.4.~~

**613.4.3 Height adjustability.** The changing surface height shall be adjustable at variable heights from 17 inches (432mm) minimum to 38 inches (965mm) maximum above the floor as measured to the top of the changing surface.

**Exception:** Where the ~~changing surface~~ adult changing station is not required by the administrative authority, a fixed height changing surface shall be permitted and shall be mounted with the top of the changing surface 19 inches (483mm) minimum and 23 inches (584 mm) maximum above the floor.

**Committee Reason:** The first modification deleted Section 613.4.1 due to concerns that some of the item were not in enforceable language (e.g. # 3 and 5). Item 1 is addressed in Section 614.4.5. Item 8 needed some editorial cleanup on the language.

The modification to Section 613.4.3 was because the adult changing station is required by the codes, not the surface itself. This is editorial.

The replacement proposal developed by the Adult Changing Station Committee was approved because it brought requirements in for the changing table that would provide appropriate guidance for these facilities. The committee worked to address concerns raised by the A117.1 committee during the original presentation to the committee at the March 10 presentation. Laurel Wright’s presentation explained the development and resources used by the task group to develop criteria.

106-WRIGHT.doc

Report for 06-90-2021		
Committee decision: AM	Committee Vote at Meeting: 26-0-0	Committee Vote on Ballot:
<b>REPORT OF HEARING:</b> Modification (if any): Further revise as follows:  <del>613.4.1 Safety and performance.</del> Adult changing stations shall comply with the following safety and performance requirements: <del>1. Protect the user from falling from the changing surface along the open long sides, by means such as retractable safety rails.</del> <del>2. Provide a belt to secure the user on the changing surface.</del> <del>3. Protect the user and caregiver from entrapment during operation.</del>		

**Report for 06-90-2021**

- ~~4. Support a weight of not less than 400 lbs. (182 kg) applied to the changing surface~~
- ~~5. Provide a method to prevent tipping such as secured to the floor or wall, or other means.~~
- ~~6. Provide a changing surface that is durable, cleanable, non-absorbent, and resistant to corrosion.~~
- ~~7. Electrical components complying with NFPA 70.~~
- ~~8. Operable controls for height adjustment and, where provided, on and off complying with Section 309.4.~~

**613.4.3 Height adjustability.** The changing surface height shall be adjustable at variable heights from 17 inches (432mm) minimum to 38 inches (965mm) maximum above the floor as measured to the top of the changing surface.

**Exception:** Where the ~~changing surface~~ **adult changing station** is not required by the administrative authority, a fixed height changing surface shall be permitted and shall be mounted with the top of the changing surface 19 inches (483mm) minimum and 23 inches (584 mm) maximum above the floor.

**Committee Reason:** The first modification deleted Section 613.4.1 due to concerns that some of the item were not in enforceable language (e.g. # 3 and 5). Item 1 is addressed in Section 614.4.5. Item 8 needed some editorial cleanup on the language.

The modification to Section 613.4.3 was because the adult changing station is required by the codes, not the surface itself. This is editorial.

The replacement proposal developed by the Adult Changing Station Committee was approved because it brought requirements in for the changing table that would provide appropriate guidance for these facilities. The committee worked to address concerns raised by the A117.1 committee during the original presentation to the committee at the March 10 presentation. Laurel Wright's presentation explained the development and resources used by the task group to develop criteria.

**PUBLIC COMMENT- FIRST DRAFT:**

Proponent:

Desired Action:

Modification:

Reason:

**Committee decision: AS/AM/D**

**Committee Vote at Meeting:**

**Committee Vote on Ballot:**

**REPORT OF HEARING – FIRST DRAFT**

Modification (if any):

Committee Reason:

**PUBLIC COMMENT- SECOND DRAFT:**

Proponent:

Desired Action:

Modification:

Reason:

**Committee decision: AS/AM/D**

**Committee Vote at Meeting:**

**Committee Vote on Ballot:**

**FINAL ACTION:**

Modification (if any):

Committee Reason:

# ICC A117.1 Committee Action Report

## Chapter 7

07-01 – 2021

703.1.2

**Proponent:** Billie Louise (Beezy) Bentzen, PhD., Accessible Design for the Blind, representing Association for the Education and Rehabilitation of the Blind and Visually Impaired (AER)

**Revise as follows:**

### SECTION 703 SIGNS

**703.1.2 Directional and informational signs.** Signs that provide direction to or information about interior spaces and facilities of the site shall comply with Section 703.2, 703.3 and 703.4.

**Exception:** Where the bottom of the sign is greater than 80 inches (2030 mm) above the floor, the sign is not required to comply with Section 703.3 and 703.4.

---

**REASON:** Directional signs that are accessible to people who are vision disabled because they are easy to find and they can be approached for close viewing can greatly reduce the need for people who are vision disabled to obtain information from other people. (See AERBVI proposed additional language to 703.3.) It is perfectly possible for people who are blind or who have low vision to travel independently in unfamiliar public environments if directional information is provided in predictable locations.

Asking strangers for wayfinding information has been found to be the least preferred way by people who are not vision disabled to get needed information. If the passenger cannot see or hear another person who is close by, and cannot judge whether a person they do detect is a person they would feel safe engaging with, and who is likely to have and be able to provide the answer to their question, asking a fellow passenger becomes an even more undesirable way to get information. Fear of getting confused or disoriented when traveling, or of being vulnerable to physical or psychological abuse, often results in isolation for people who are vision disabled, or the use of alternative means of travel, such as paratransit (which is expensive for the traveler and even more so for the transit system), taxi, or friends or relatives whom they do not want to inconvenience. Unlike transit facilities, most of which, during most daytime hours will have numerous people passing by, corridors in public buildings, especially office buildings, often have no people traveling in them who could provide directional information. Having no accessible directional signage in public buildings often results in the perceived need by people who are vision disabled to travel with a companion, lest they get lost.

Additional support for this concept and the need for it may be found in Ardit, A. (2017). Rethinking ADA signage standards for low vision accessibility. *J Vis.* 2017; 17(5): 8. Published online 2017 May 16. doi: 10.1167/17.5.8 (attached), and Arthur, P., & Passini, R.. (1992). *Wayfinding: People, signs, and architecture*. New York: McGraw Hill. Pp. 200-202.

The intent of the exception is to not require raised letters or braille on overhead signage. If the directional sign is in the wall the baseline of the rows would have to be between 48” and 60” because of Section 703.3.10 and 703.4.5.

**Committee Action:** Disapproval 24-0-5

**REPORT OF HEARING:**

**Modification (if any):**

**Committee Reason:** The concerns in the reason were about directional information, but this section also addressed information about the space. Tactile letters do not work for all the directional signage scoped IBC Section 1112.3 since not all are at doors or corridor intersections where signs could be located by a person with a vision impairment. It is not clear what information would be required – directional arrow, room names/numbers? Since the tactile signage is between 48” and 60”, the exception for 80” is not consistent with tactile sign location. This item should be a discussion point for the Communications task group.

**703.1.2-BENTZEN.doc**

<b>Report for 07-01– 2021</b>		
<i>Committee decision: D</i>	<i>Committee Vote at Meeting: 24-0-5</i>	<i>Committee Vote on Ballot:</i>
<b>REPORT OF HEARING:</b>		
Modification (if any):		
Committee Reason: The concerns in the reason were about directional information, but this section also addressed information about the space. Tactile letters do not work for all the directional signage scoped IBC Section 1112.3 since not all are at doors or corridor intersections where signs could be located by a person with a vision impairment. It is not clear what information would be required – directional arrow, room names/numbers? Since the tactile signage is between 48” and 60”, the exception for 80” is not consistent with tactile sign location. This item should be a discussion point for the Communications task group.		
<b>PUBLIC COMMENT- FIRST DRAFT:</b>		
Proponent:		
Desired Action:		
Modification:		
Reason:		
<i>Committee decision: AS/AM/D</i>	<i>Committee Vote at Meeting:</i>	<i>Committee Vote on Ballot:</i>
<b>REPORT OF HEARING – FIRST DRAFT</b>		
Modification (if any):		
Committee Reason:		
<b>PUBLIC COMMENT- SECOND DRAFT:</b>		
Proponent:		
Desired Action:		
Modification:		
Reason:		
<i>Committee decision: AS/AM/D</i>	<i>Committee Vote at Meeting:</i>	<i>Committee Vote on Ballot:</i>
<b>FINAL ACTION:</b>		
Modification (if any):		
Committee Reason:		

## 07-02 – 2021

### 703.1.3

**Proponent:** Sharon Toji, Access Communications

**Revise as follows:**

#### SECTION 703 SIGNS

**703.1.3 Pictograms.** Where pictograms are provided as designations of permanent interior rooms and spaces, the pictograms shall comply with Section 703.5 and shall have text descriptors located directly below the pictogram field and complying with Sections 703.2 and 703.3. Where the visual and raised characters text descriptors are separate signs, only the visual characters shall be required below the pictogram.

**Exception:** Pictograms that provide information about a room or space, such as “No Smoking,” occupant logos, and the International Symbol of Accessibility, shall not be required to have text descriptors.

**REASON:** We have found great acceptance of so-called “dual purpose signs” where the visual sign text is separated from the tactile and braille text, both by blind people who do not read braille as well as by people with partial vision who want larger, bolder visual text that exceeds tactile standards. Since we promote using pictograms for restrooms, it is difficult to separate them if we are exacting about the standards, which might mean having to keep the pictogram above both the visual and tactile versions, even though those who read solely by touch do not use the pictograms. Therefore, it seems helpful to indicate that pictograms that designate spaces only need to be included above the visual text. It provides for greater access for the partially sighted readers, as well as greater design freedom for sign designers.

---

## 07-02 – 2021 Replacement

### 703.1.3

**Proponent:** Sharon Toji, Access Communications

**Replace and revise as follows:**

**703.1.3 Pictograms.** Where pictograms are provided as designations of permanent interior rooms and spaces, the pictograms shall comply with Section 703.5. Pictograms and shall have text descriptors located directly below the pictogram field and complying with Sections 703.2 and 703.3 located directly below the pictogram field.

**Exception Exceptions:**



1. Pictograms that provide information about a room or space, such as “No Smoking,” occupant logos, and the International Symbol of Accessibility, shall not be required to have text descriptors.
2. Where room designations with text descriptors for pictograms are provided on separate visual and tactile signs as permitted by Section 703.1, the visual and tactile components of the text descriptor shall be permitted to be displayed separately with the associated visual or tactile sign.

**REASON:** This modification is offered to clarify that the visual and tactile components of text descriptors for pictograms are permitted to be separated from the pictogram and provided on separate visual and tactile signs. The intent is that the visual text descriptor will remain with the pictogram which is visual only and that the tactile text descriptor will be located on a sign without a visual pictogram.

**Committee Action:** Approved as Modified 21-2-6

**REPORT OF HEARING:**

**Modification (if any):**  
**Replace and revise as follows:**

**703.1.3 Pictograms.** Where pictograms are provided as designations of permanent interior rooms and spaces, the pictograms shall comply with Section 703.5. Pictograms ~~and~~ shall have text descriptors ~~located directly below the pictogram field and~~ complying with Sections 703.2 and 703.3 located directly below the pictogram field.

**Exception Exceptions:**

1. Pictograms that provide information about a room or space, such as “No Smoking,” occupant logos, and the International Symbol of Accessibility, shall not be required to have text descriptors.
2. Where room designations with text descriptors for pictograms are provided on separate visual and tactile signs as permitted by Section 703.1, the visual and tactile components of the text descriptor shall be permitted to be displayed separately with the associated visual or tactile sign.

**Committee Reason:** The modification replaced the original proposal. (This modification was not distributed before the meeting.) The new exception two is consistent with the allowances in Section 703.1 for the visual information to be separate from the raised letters and braille. The intent is to allow the pictogram and visual to be on one sign, and the raised and braille located on another sign without a pictogram.

**703.1.3-TOJI.doc**

<b>Report for 07-02- 2021</b>		
<i>Committee decision: AM</i>	<i>Committee Vote at Meeting: 21-2-6</i>	<i>Committee Vote on Ballot:</i>
<b>REPORT OF HEARING:</b>		
Modification (if any):		



**Report for 07-02– 2021**

Replace and revise as follows:

**703.1.3 Pictograms.** Where pictograms are provided as designations of permanent interior rooms and spaces, the pictograms shall comply with Section 703.5. ~~Pictograms and shall have text descriptors located directly below the pictogram field and complying with Sections 703.2 and 703.3 located directly below the pictogram field.~~

**Exception Exceptions:**

1. Pictograms that provide information about a room or space, such as “No Smoking,” occupant logos, and the International Symbol of Accessibility, shall not be required to have text descriptors.
2. ~~Where room designations with text descriptors for pictograms are provided on separate visual and tactile signs as permitted by Section 703.1, the visual and tactile components of the text descriptor shall be permitted to be displayed separately with the associated visual or tactile sign.~~

Committee Reason: The modification replaced the original proposal. (This modification was not distributed before the meeting.) The new exception two is consistent with the allowances in Section 703.1 for the visual information to be separate from the raised letters and braille. The intent is to allow the pictogram and visual to be on one sign, and the raised and braille located on another sign located without a pictogram.

**PUBLIC COMMENT- FIRST DRAFT:**

Proponent:

Desired Action:

Modification:

Reason:

**Committee decision: AS/AM/D**

**Committee Vote at Meeting:**

**Committee Vote on Ballot:**

**REPORT OF HEARING – FIRST DRAFT**

Modification (if any):

Committee Reason:

**PUBLIC COMMENT- SECOND DRAFT:**

Proponent:

Desired Action:

Modification:

Reason:

**Committee decision: AS/AM/D**

**Committee Vote at Meeting:**

**Committee Vote on Ballot:**

**FINAL ACTION:**

Modification (if any):

Committee Reason:

# 07-03 – 2021

## 703.1.3

**Proponent:** Billie Louise (Beezy) Bentzen, PhD., Accessible Design for the Blind, representing Association for the Education and Rehabilitation of the Blind and Visually Impaired (AER)

**Revise as follows:**

### SECTION 703 SIGNS

**703.1.3. Pictograms.** Where pictograms are provided as designations of permanent interior rooms and spaces, the pictograms shall comply with Section 703.5 and shall have text descriptors located directly below the pictogram field and complying with Sections 703.2 and 703.3.

**Exception:** Pictograms ~~that provide information about a room or space, such as “No Smoking,”~~ depicting occupant logos, and the International Symbol of Accessibility, shall not be required to have text descriptors.

---

**REASON:** The pictogram for “No Smoking” is important communication for people who are vision disabled. It is not reliably discriminated and recognized by them and needs to have text description.

**Committee Action:** As Submitted 25-2-4

#### REPORT OF HEARING:

**Modification (if any):**

**Committee Reason:** The Communications work group agreed with the proposal, but did not agree with the reason. The room designation is the base requirement, so the exception should be limited to the designation, not information about the room. We further agree with their recommendation that the exception language is not appropriate since a “no smoking” pictogram does not fall within the permanent interior rooms and spaces category.

**703.1.3-BENTZEN.doc**

<b>Report for 07-03– 2021</b>		
<b>Committee decision:</b> AS	<b>Committee Vote at Meeting:</b> 25-2-4	<b>Committee Vote on Ballot:</b>
<b>REPORT OF HEARING:</b>		
Modification (if any):		
Committee Reason: The Communications work group agreed with the proposal, but did not agree with the reason. The room designation is the base requirement, so the exception should be limited to the designation, not information about the room. We further agree with their recommendation that the exception language is not appropriate since a “no smoking” pictogram does not fall within the permanent interior rooms and spaces category.		
<b>PUBLIC COMMENT- FIRST DRAFT:</b>		

<b>Report for 07-03– 2021</b>		
Proponent:		
Desired Action:		
Modification:		
Reason:		
<b>Committee decision: AS/AM/D</b>	<b>Committee Vote at Meeting:</b>	<b>Committee Vote on Ballot:</b>
<b>REPORT OF HEARING – FIRST DRAFT</b>		
Modification (if any):		
Committee Reason:		
<b>PUBLIC COMMENT- SECOND DRAFT:</b>		
Proponent:		
Desired Action:		
Modification:		
Reason:		
<b>Committee decision: AS/AM/D</b>	<b>Committee Vote at Meeting:</b>	<b>Committee Vote on Ballot:</b>
<b>FINAL ACTION:</b>		
Modification (if any):		
Committee Reason:		

**07-04 – 2021**

**703.2.4 (New), 703.3.5 (New)**

**Proponent:** Kimberly Paarlberg, International Code Council

**Add new text as follows:**

**SECTION 703  
SIGNS**

**703.2 Visual Characters**

**703.2.4 Text orientation:** The lines of visual text characters shall be displayed with the base line of the text in either in a vertical or horizontal orientation.

**Exception:** Numeric characters are permitted to be displayed in a vertical orientation, one under another.

**703.3 Raised characters.**

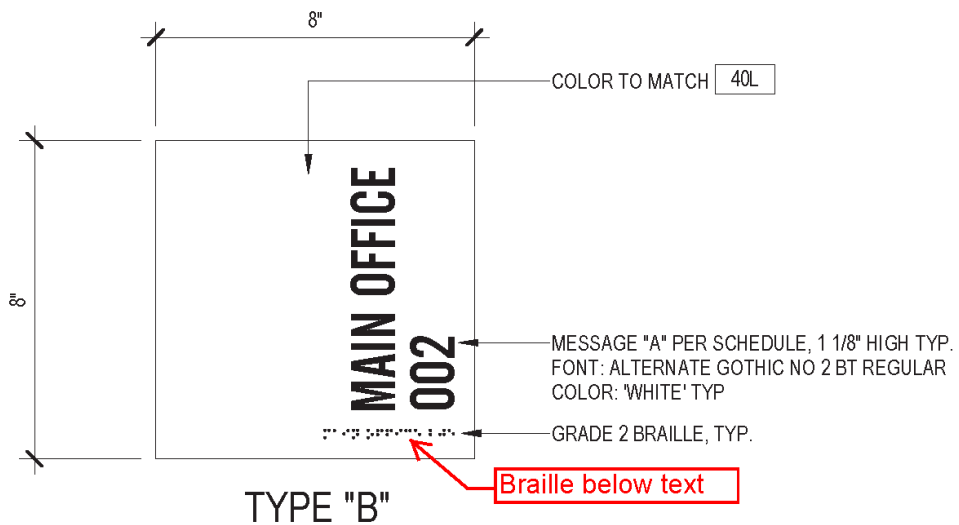
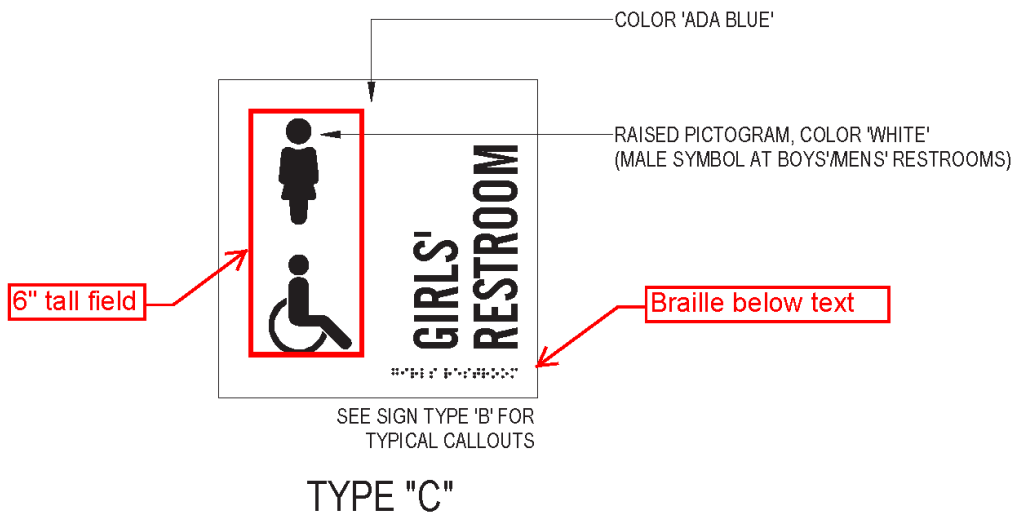
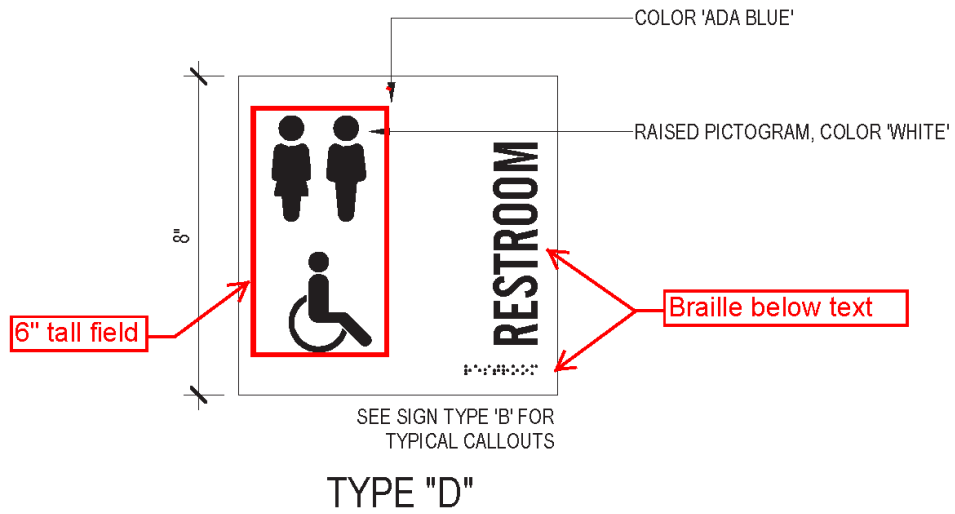
**703.3.5 Text orientation:** Raised characters shall be displayed in a horizontal orientation.

---

**REASON:** The standard does not currently provide any guidance regarding the orientation of either visual or raised characters. We have received several questions regarding whether the standard allows visual characters to be displayed in a vertical line. See the attached image as an example of a sign that was proposed to illustrate the issue that is trying to be addressed by this change.

This is an attempt to clarify an issue which is currently unaddressed within the standard. Where a sign is numbers only, there is nothing within the current text that says the numbers cannot be one under another instead of being placed horizontally in a row. However, although not stated, they should be oriented in a standard vertical manner even if each digit is displayed on a separate line which complies with the appropriate line spacing. As the image shows, numerals cannot be easily read when oriented horizontally (sideways) and thus they should not be rotated.

The intent of this proposal is to require that raised characters must be oriented on a horizontal line of text and that numerals be kept in a vertical orientation. Visual characters would be permitted to be oriented onto a vertical line of text. Braille is not addressed by this proposal and is assumed to be adequately addressed by the “contracted (Grade 2) braille” requirement of Section 703.4.1.



---

## 07-04 – 2021 modification

**Proponent:** Kimberly Paarlberg, International Code Council

**Further revise as follows:**

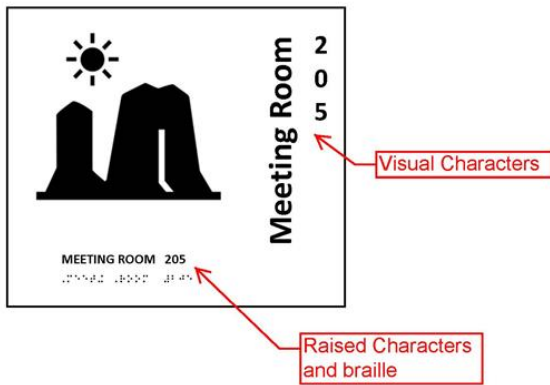
### 703.4 Braille

**703.4.4 Position.** Braille shall be below the corresponding text and displayed in a horizontal orientation. If text is multilined, braille shall be placed below entire text. Braille shall be separated  $\frac{3}{8}$  inch (9.5 mm) minimum from any other raised characters and  $\frac{3}{8}$  inch (9.5 mm) minimum from raised borders and decorative elements. Braille provided on elevator car controls shall be separated  $\frac{3}{16}$  inch (4.8 mm) minimum either directly below or adjacent to the corresponding raised characters or symbols.

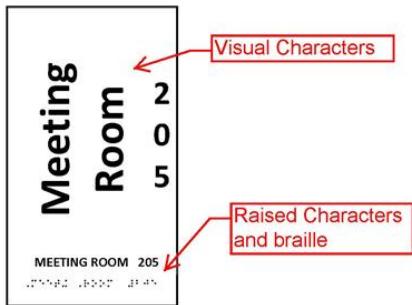
**Reason:** The reason in the original proposal did not show compliant examples, just the issue of signage. There were also concerns that the information for the braille should also include the horizontal requirement. The examples below are compliant examples.



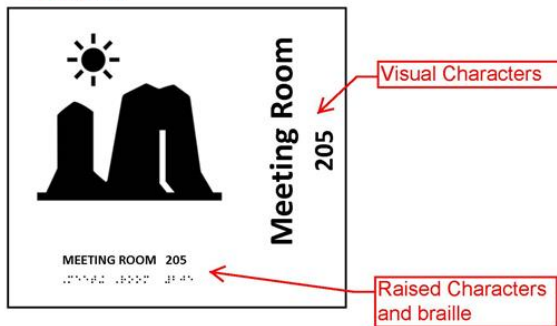
Compliant



compliant



Compliant



## 07-04 – 2021 2<sup>nd</sup> modification

**Proponent:** Sharon Toji, Access Communications

**Further revise as follows:**

**703.2.4 Text orientation:** The lines of visual text characters shall be displayed with the base line of the text in ~~either in a vertical or a~~ horizontal orientation.

~~**Exception:** Numeric characters are permitted to be displayed in a vertical orientation, one under another.~~

Reason: Vertical visual text is difficult for persons with partial vision to read. The State of California added text similar to the above for both visual and tactile characters and braille cells quite a few years ago, and has not had a negative response from building owners or designers.

---

**Committee Action:** Approved as Modified AM 23-0-2  
Mod 2 – AM – 22-0-3  
Mod 1 – AM –24-0-4

### REPORT OF HEARING:

**Modification (if any):**

**Further revise as follows:**

**703.2.4 Text orientation:** The lines of visual text characters shall be displayed with the base line of the text in ~~either in a vertical or a~~ horizontal orientation.

~~**Exception:** Numeric characters are permitted to be displayed in a vertical orientation, one under another.~~

**703.4.4 Position.** Braille shall be below the corresponding text and displayed in a horizontal orientation. If text is multilined, braille shall be placed below entire text. Braille shall be separated  $\frac{3}{8}$  inch (9.5 mm) minimum from any other raised characters and  $\frac{3}{8}$  inch (9.5 mm) minimum from raised borders and decorative elements. Braille provided on elevator car controls shall be separated  $\frac{3}{16}$  inch (4.8 mm) minimum either directly below or adjacent to the corresponding raised characters or symbols.

**Committee Reason:** The current text does not specify a direction of the information on accessible signs. The original proposal direction of that information for visual and raised letters. The modification to new Section 703.2.4 limits the text orientation of visual signage to horizontal. Accessible visual signs should be horizontal for readability for persons with visual or



cognitive disabilities. The modification to Section 703.4.4 is to require braille to be horizontal consistent with the visual and raised characters.

**703.2.4-PAARLBERG.doc**

<b>Report for 07-04- 2021</b>		
<b>Committee decision: AM</b>	<b>Committee Vote at Meeting: 23-0-2</b>	<b>Committee Vote on Ballot:</b>
<b>REPORT OF HEARING:</b>		
Modification (if any):		
<b>Further revise as follows:</b>		
<p><b>703.2.4 Text orientation:</b> The lines of visual text characters shall be displayed with the base line of the text in <del>either in a vertical or a</del> horizontal orientation.</p> <p><b>Exception:</b> Numeric characters are permitted to be displayed in a vertical orientation, one under another.</p>		
<p><b>703.4.4 Position.</b> Braille shall be below the corresponding text <u>and displayed in a horizontal orientation</u>. If text is multilined, braille shall be placed below entire text. Braille shall be separated <math>\frac{3}{8}</math> inch (9.5 mm) minimum from any other raised characters and <math>\frac{3}{8}</math> inch (9.5 mm) minimum from raised borders and decorative elements. Braille provided on elevator car controls shall be separated <math>\frac{3}{16}</math> inch (4.8 mm) minimum either directly below or adjacent to the corresponding raised characters or symbols.</p>		
<p>Committee Reason: The current text does not specify a direction of the information on accessible signs. The original proposal direction of that information for visual and raised letters. The modification to new Section 703.2.4 limits the text orientation of visual signage to horizontal. Accessible visual signs should be horizontal for readability for persons with visual or cognitive disabilities. The modification to Section 703.4.4 is to require braille to be horizontal consistent with the visual and raised characters.</p>		
<b>PUBLIC COMMENT- FIRST DRAFT:</b>		
Proponent:		
Desired Action:		
Modification:		
Reason:		
<b>Committee decision: AS/AM/D</b>	<b>Committee Vote at Meeting:</b>	<b>Committee Vote on Ballot:</b>
<b>REPORT OF HEARING – FIRST DRAFT</b>		
Modification (if any):		
Committee Reason:		
<b>PUBLIC COMMENT- SECOND DRAFT:</b>		
Proponent:		
Desired Action:		
Modification:		
Reason:		
<b>Committee decision: AS/AM/D</b>	<b>Committee Vote at Meeting:</b>	<b>Committee Vote on Ballot:</b>
<b>FINAL ACTION:</b>		
Modification (if any):		
Committee Reason:		

**07-05 – 2021**  
**703.2.4**

**Proponent:** Sharon Toji, Access Communications

**Revise as follows:**

**SECTION 703**  
**SIGNS**

**703.2 Visual characters.**

**703.2.4 Character height.** The uppercase letter “I” shall be used to determine the allowable height of all characters of a font. The uppercase letter “I” of the font shall have a minimum height complying with Table 703.2.4. Viewing distance shall be measured as the horizontal distance between the character and an obstruction preventing further approach towards the sign.

**Exception Exceptions:**

1. In assembly seating where the maximum viewing distance is 100 feet (30.5 m) or greater, the height of the uppercase “I” of fonts shall be permitted to be 1 inch (25 mm) for every 30 feet (9145 mm) of viewing distance, provided the character height is 8 inches (205 mm) minimum. Viewing distance shall be measured as the horizontal distance between the character and where someone is expected to view the sign.
2. Site and floor maps, evacuation plans, building directories and signs providing instructions on the operation of equipment shall not be required to comply with the minimum character height in Table 703.2.4 for visual text.

**TABLE 703.2.4—VISUAL CHARACTER HEIGHT**

<b>Height above Floor to Baseline of Character<sup>1</sup></b>	<b>Horizontal Viewing Distance</b>	<b>Minimum Character Height</b>
40 inches (1015 mm) to less than or equal to 70 inches (1780 mm)	Less than 6 feet (1830 mm)	<sup>5</sup> / <sub>8</sub> inch (16 mm)
	6 feet (1830 mm) and greater	<sup>5</sup> / <sub>8</sub> inch (16 mm), plus <sup>1</sup> / <sub>8</sub> inch (3.2 mm) per foot (305 mm) of viewing distance above 6 feet (1830 mm)
Greater than 70 inches (1780 mm) to less than or equal to 120 inches (3050 mm)	Less than 15 feet (4570 mm)	2 inches (51 mm)
	15 feet (4570 mm) and greater	2 inches (51 mm), plus <sup>1</sup> / <sub>8</sub> inch (3.2 mm) per foot (305 mm) of viewing distance above 15 feet (4570 mm)

Greater than 120 inches (3050 mm)	Less than 21 feet (6400 mm)	3 inches (75 mm)
	21 feet (6400 mm) and greater	3 inches (75 mm), plus 1/8 inch (3.2 mm) per foot (305 mm) of viewing distance above 21 feet (6400 mm)

1. The vertical height is measured from the floor of the viewing position to the baseline of the highest line of characters.

---

**REASON:** Although there should be some minimum size requirements for the visual characters on the sign types listed in this exception, the blanket requirement for 5/8 inch (and perhaps now 1 inch) high characters has provided a great deal of concern and frustration. In California, for instance, the state just exempted evacuation plans (but not site and floor maps) because using 5/8 inch high characters throughout would have made the signs get so large that sections of the signs would have been mounted too high for little people and people in wheelchairs to read them, especially if they had impaired vision. In addition, the text was taking up so much space on the signs that the floor plan itself, which provided the most useful evacuation or wayfinding information, was often minimized.

The tendency is to just exempt signs that present problems. Instead, we need to decide which information is most important to be able to see from a greater distance, and which can be smaller for close reading. We need to exempt only those elements of the sign that are impossible to make compliant, but retain requirements that are possible to emphasize for increased access.

In the meantime, since signs like site plans and building directories would stretch along entire walls and extend upwards too high to see if they followed these requirements for even the smallest text, it makes sense right now to exempt them from the type size requirements and plan to study these types of signs to see what sensible requirements can be put in place.

**Committee Action:** Disapproval 24-0-0

**REPORT OF HEARING:**

**Modification (if any):**

**Committee Reason:** The exception should not include items that are not scoped to the standard. This needs to be coordinated with the scoping provisions. “Operation of equipment” is too broad for these requirements. This proposal needs to be narrowed down to what specific items the concerns are. The Communications task group will be looking at these items individually.

**703.2.4-TOJI.doc**

<b>Report for 07-05– 2021</b>		
<i>Committee decision: D</i>	<i>Committee Vote at Meeting: 24-0-0</i>	<i>Committee Vote on Ballot:</i>

<b>Report for 07-05– 2021</b>		
<b>REPORT OF HEARING:</b>		
Modification (if any):		
Committee Reason: The exception should not include items that are not scoped to the standard. This needs to be coordinated with the scoping provisions. "Operation of equipment" is too broad for these requirements. This proposal needs to be narrowed down to what specific items the concerns are. The Communications task group will be looking at these items individually.		
<b>PUBLIC COMMENT- FIRST DRAFT:</b>		
Proponent:		
Desired Action:		
Modification:		
Reason:		
<b>Committee decision: AS/AM/D</b>	<b>Committee Vote at Meeting:</b>	<b>Committee Vote on Ballot:</b>
<b>REPORT OF HEARING – FIRST DRAFT</b>		
Modification (if any):		
Committee Reason:		
<b>PUBLIC COMMENT- SECOND DRAFT:</b>		
Proponent:		
Desired Action:		
Modification:		
Reason:		
<b>Committee decision: AS/AM/D</b>	<b>Committee Vote at Meeting:</b>	<b>Committee Vote on Ballot:</b>
<b>FINAL ACTION:</b>		
Modification (if any):		
Committee Reason:		

# **ICC A117.1 Committee Action Report Chapter 8**

# ICC A117.1 Committee Action Report

## Chapter 9

**09-05 – 2021**

**908(New)**

**Proponent:** Kimberly Paarlberg, International Code Council

**Add new text as follows:**

### **SECTION 908** **TRASH OR LINEN CHUTES**

**908.1 General.** Waste, recycling and linen chutes serving Accessible and Type A units are required to be on an accessible route and comply with Section 908.2 through 908.4.

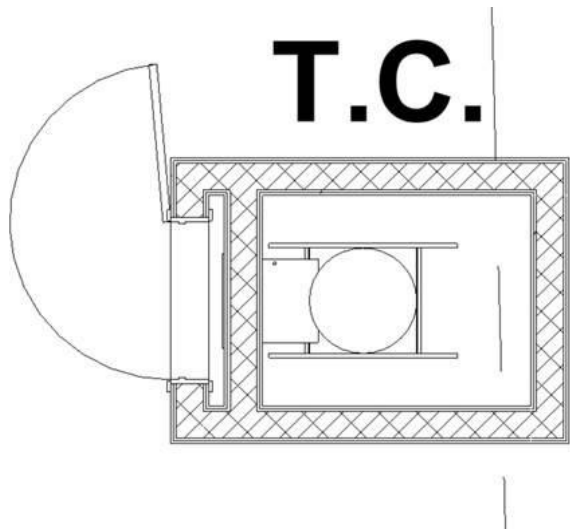
**908.2 Doors to trash or linen chutes.** Doors to waste, recycling and linen chutes rooms or trash or linen chute access panels shall comply with 404.

**908.3 Trash or linen chute access panels.** Access panels for waste, recycling and linen chutes shall have hardware complying with 404.2.6. The access panel opening forces shall have the minimum opening force allowable by the scoping provisions adopted by the appropriate administrative authority.

**908.4 Room requirements.** Where there is a room in front of the access panel for waste, recycling or linen chutes, a turning space shall be provided in the room and maneuvering clearances shall be provided on both sides of the door. Where the access panel for the waste, recycling or linen chute is located behind a corridor door, the door shall have a magnetic hold open that allows for automatic-closing upon the detection of smoke.

---

**REASON:** The purpose of this proposal is to provide technical criteria for accessibility for trash chutes and linen chutes. Since these are vertical shafts, the walls are required to be fire resistance rated. Both the door to the access the chute, and the door to the chute itself are required to be fire resistance rated. That requires closures and latches on the door.



## 2021 IBC

**713.13 Waste, recycling and linen chutes and incinerator rooms.** Waste, recycling and linen chutes shall comply with the provisions of NFPA 82, Chapter 6 and shall meet the requirements of Sections 712 and 713.13.1 through 713.13.6. Incinerator rooms shall meet the provisions of Sections 713.13.4 and 713.13.5.

**Exception:** Chutes serving and contained within a single *dwelling unit*.

**713.13.1 Waste, recycling and linen chute enclosures.** A *shaft enclosure* containing a recycling, waste or linen chute shall not be used for any other purpose and shall be enclosed in accordance with Section 713.4. A *shaft enclosure* shall be permitted to contain recycling and waste chutes. Openings into the *shaft*, from access rooms and discharge rooms, shall be protected in accordance with

this section and Section 716. Openings into chutes shall not be located in *corridors*. Doors into chutes shall be *self-closing*. Discharge doors shall be self- or automatic closing upon the actuation of a smoke detector in accordance with Section 716.2.6.6, except that heat-activated closing devices shall be permitted between the *shaft* and the discharge room.

**713.13.2 Materials.** A *shaft enclosure* containing a waste, recycling, or linen chute shall be constructed of materials as permitted by the building type of construction.

**713.13.3 Chute access rooms.** Access openings for waste, recycling or linen chutes shall be located in rooms or compartments enclosed by not less than 1-hour *fire barriers* constructed in accordance with Section 707 or *horizontal assemblies* constructed in accordance with Section 711, or both. Openings into the access rooms shall be protected by opening protectives having a *fire protection rating* of not less than 3/4 hour. Doors shall be self- or automatic-closing upon the detection of smoke in accordance with Section 716.2.6.6. The room or compartment shall be configured to allow the access door to the room or compartment to close and latch with the access panel to the chute in any position.

---

Committee Action:

18-12-1

AS

**REPORT OF HEARING:  
Modification (if any):**

**Committee Reason:** This is a common issue that needs to be moved forward. The proposal provides technical criteria for accessibility for trash chutes and linen chutes. Since these are vertical shafts, the walls are required to be fire resistance rated. Both the door to the access the chute, and the door to the chute itself are required to be fire resistance rated, and that requires closures and latches on the door.

**908-PAARLBERG.doc**

<b>Report for 09-05– 2021</b>		
<b>Committee decision: AS</b>	<b>Committee Vote at Meeting: 18-12-1</b>	<b>Committee Vote on Ballot:</b>
<b>REPORT OF HEARING:</b>		
Modification (if any):		
Committee Reason: This is a common issue that needs to be moved forward. The proposal provides technical criteria for accessibility for trash chutes and linen chutes. Since these are vertical shafts, the walls are required to be fire resistance rated. Both the door to the access the chute, and the door to the chute itself are required to be fire resistance rated, and that requires closures and latches on the door.		
<b>PUBLIC COMMENT- FIRST DRAFT:</b>		
Proponent:		
Desired Action:		
Modification:		
Reason:		
<b>Committee decision: AS/AM/D</b>	<b>Committee Vote at Meeting:</b>	<b>Committee Vote on Ballot:</b>
<b>REPORT OF HEARING – FIRST DRAFT</b>		
Modification (if any):		
Committee Reason:		
<b>PUBLIC COMMENT- SECOND DRAFT:</b>		
Proponent:		
Desired Action:		
Modification:		
Reason:		
<b>Committee decision: AS/AM/D</b>	<b>Committee Vote at Meeting:</b>	<b>Committee Vote on Ballot:</b>
<b>FINAL ACTION:</b>		
Modification (if any):		
Committee Reason:		



# **ICC A117.1 Committee Action Report**

## **Chapter 10**

# ICC A117.1 Committee Action Report

## Chapter 11

**11-14 – 2021**

**1103.12.1.1, 1103.12.1.2, 1104.12.1.1, 1104.12.1.2**

**Proponent:** Marsha Mazz, representing United Spinal Association

**Revise as follows:**

### **SECTION 1103 TYPE A UNITS**

**1103.12.1.1 Minimum clearance.** Clearance between all opposing base cabinets, countertops, appliances, or walls within kitchen work areas shall be 40 inches (1015 mm) minimum measured at the narrowest point, excluding hardware and appliance controls.

**1103.12.1.2 U-shaped kitchens.** In kitchens with counters, appliances, or cabinets on three contiguous sides, clearance between all opposing base cabinets, countertops, appliances, or walls within kitchen work areas shall be 60 inches (1525 mm) minimum measured at the narrowest point, excluding hardware and appliance controls.

**Exception:** U-shaped kitchens with an island complying with Section 1103.12.1.1.

### **SECTION 1104 TYPE B UNITS**

**1104.12.1.1 Minimum clearance.** Clearance between all opposing base cabinets, countertops, appliances, or walls within kitchen work areas shall be 40 inches (1015 mm) minimum measured at the narrowest point, excluding hardware and appliance controls.

**1104.12.1.2 U-shaped kitchens.** In kitchens with counters, appliances or cabinets on three contiguous sides, clearance between all opposing base cabinets, countertops, appliances, or walls within kitchen work areas shall be 60 inches (1525 mm) minimum measured at the narrowest point, excluding hardware and appliance controls.

**Exception:** U-shaped kitchens with an island complying with Section 1104.12.1.1.

---

**REASON:** Kitchens in Accessible units and those outside dwelling units must comply with Section 804. This proposal addresses Type A and Type B units. Please see our companion proposals to make the same change to Section 804.2.

Some inspectors include hardware and appliance controls when measuring between base cabinets and appliances, others do not. This proposal is intended to establish a clear

measurement point. The narrowest kitchen clearance is 40 inches in width which is at least 4 inches wider than an accessible route, 8 inches where Exception 1 to Section 403.5.1 allows the route to reduce to 32 inches for a distance of 24 inches.

For Type B units (Section 1104.12.1), HUD’s Fair Housing Design Manual makes clear that hardware and appliance controls are to be excluded when measuring kitchen clearances.

“The Guidelines require a clearance of at least 40 inches between all opposing base cabinets, countertops, appliances, and walls. The 40-inch clearance is measured from any countertop or the face of any appliance (excluding handles and controls) that projects into the kitchen to the opposing cabinet, countertop, appliance, or wall. Refrigerators vary greatly in depth and may extend up to eight inches beyond cabinet faces. Standard free-standing and drop-in ranges may project up to three inches. Appliance depths (excluding door handles) must be included when calculating the 40-inch clearances.”

Requirement #7 (1)(b) of the Fair Housing Act Accessibility Guidelines says it a little differently.

“Clearance between counters and all opposing base cabinets, countertops, appliances, or walls is at least 40 inches”.

Unfortunately, neither the Design Manual or the Guidelines shed any light on where the measurement is to be taken when the countertop overhangs the face of the cabinet or an appliance, such as a dishwasher. This proposal clarifies what we believe is the intent of the HUD requirement by requiring the measurement to be taken at the narrowest point. We have proposed the same change for Sections 804 and 1103.12.1.

Committee Action: AS 23-2-3

**REPORT OF HEARING:  
Modification (if any):**

**Committee Reason:** The committee agreed with the proponent’s reason statement - that the measurement for kitchens should not include handles on cabinets and appliance controls or handles. There are some reviewers that are misinterpreting this. For consistency, this should also be considered for the kitchen requirements in Section 804.

**1103.12.1-MAZZ.doc**

<b>Report for 11-14- 2021</b>		
<b>Committee decision: AS</b>	<b>Committee Vote at Meeting: 23-2-3</b>	<b>Committee Vote on Ballot:</b>
<b>REPORT OF HEARING:</b>		
Modification (if any):		
Committee Reason: The committee agreed with the proponent’s reason statement - that the measurement for kitchens should not include handles on cabinets and appliance controls or handles. There are some reviewers that are misinterpreting this. For consistency, this should also be considered for the kitchen requirements in Section 804.		
<b>PUBLIC COMMENT- FIRST DRAFT:</b>		
Proponent:		
Desired Action:		
Modification:		
Reason:		
<b>Committee decision: AS/AM/D</b>	<b>Committee Vote at Meeting:</b>	<b>Committee Vote on Ballot:</b>
<b>REPORT OF HEARING – FIRST DRAFT</b>		
Modification (if any):		
Committee Reason:		
<b>PUBLIC COMMENT- SECOND DRAFT:</b>		

<b>Report for 11-14- 2021</b>		
Proponent:		
Desired Action:		
Modification:		
Reason:		
<b>Committee decision: AS/AM/D</b>	<b>Committee Vote at Meeting:</b>	<b>Committee Vote on Ballot:</b>
<b>FINAL ACTION:</b>		
Modification (if any):		
Committee Reason:		

## 11-29 – 2021

**1104.11.3.1.3, 1104.11.3.1.3.1, 1104.11.3.1.3.2, 1104.11.3.1.3.3, 1104.11.3.2.3.1; Figures 1104.11.3.1.3.1, 1104.11.3.1.3.2, 1104.11.3.1.3.3(A), 1104.11.3.1.3.3(B), 1104.11.3.2.3.1**

**Proponent:** Thomas Hirsch, FAIA, Hirsch Group Architecture, representing self; M. Bradley Gaskins, AIA; Gina Hillberry for United Cerebral Palsy; Joe Jurkiewicz, AIA; Marsha Mazz for United Spinal Association; Edward Steinfeld, Arch.D, AIA; and Steven R. Winkel, FAIA, PE, CASp

**Revise as follows:**

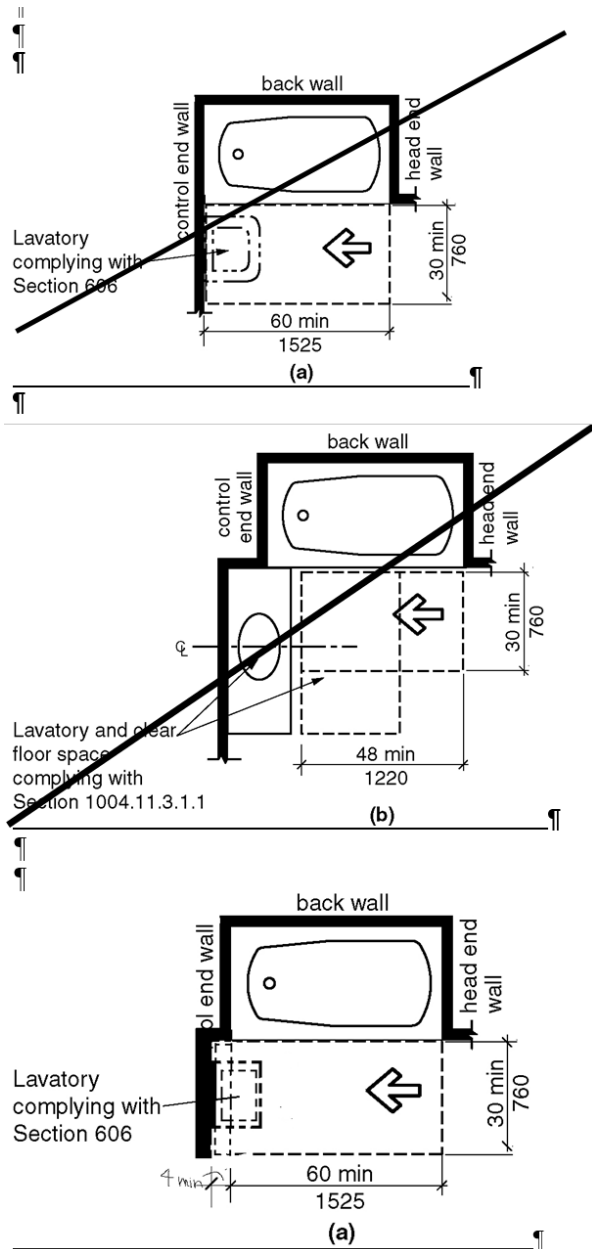
### **SECTION 1104 TYPE B UNITS**

**1104.11.3.1 Option A.** *(no change)*

**1104.11.3.1.3 Bathing fixtures.** Where provided, a bathtub shall comply with Section 1104.11.3.1.3.1 ~~or 1104.11.3.1.3.2~~ and a shower compartment shall comply with Section ~~1104.11.3.1.3.2~~ 1104.11.3.1.3.3.

**1104.11.3.1.3.1 Parallel approach to bathtubs.** A transfer clearance of 60 inches (1525 mm) minimum in length and 48" (1220 mm) minimum shall be provided in front of bathtubs with a parallel approach. A clear floor space for toe clearance at the controls shall extend 4 inch (102 mm) minimum beyond the control end wall. Lavatories complying with Section 606 shall be permitted in the transfer and control clearance. ~~A lavatory complying with Section 1104.11.3.1.1 shall be permitted if a clearance 48" (1220 mm) in length and 30 inches (760 mm) minimum in width is provided in front of the bathtub.~~

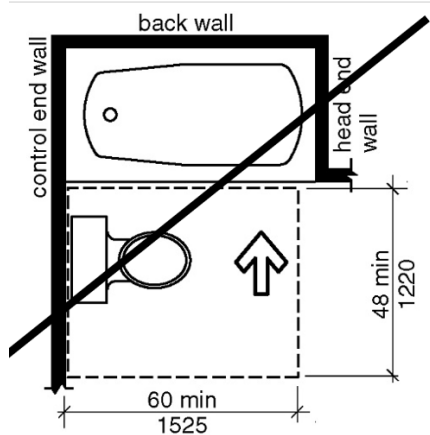
*Note: Replace Figure 1104.11.3.1.3.1 (a) and (b) with one figure. The new figure indicates the transfer clearance and the additional 4 inches required for the control clearance.*



**FIGURE 1104.11.3.1.3.1**

**PARALLEL APPROACH BATHTUB IN TYPE B UNITS - OPTION A BATHROOM**

**1104.11.3.1.3.2 Forward approach to bathtubs.** A clearance of 60 inches (1525 mm) minimum in length and 48 inches (1220 mm) minimum shall be provided in front of bathtubs with a forward approach. A water closet and a lavatory shall be permitted in the clearance at the foot one end of the bathtub.



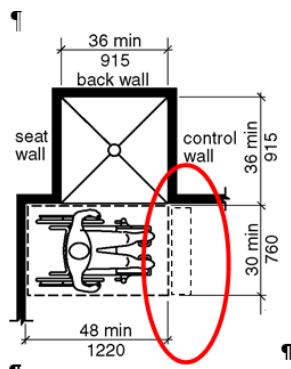
**FIGURE 1104.11.3.1.3.2**  
**~~FORWARD APPROACH BATHTUB IN TYPE B UNITS OPTION A BATHROOM~~**

**1104.11.3.1.3.2 1104.11.3.1.3.3 Shower compartments.** If the shower compartment is the only bathing facility, the shower shall have dimensions of 36 inches minimum in width and 36 inches (915 mm) minimum in depth. A transfer clearance of 48 inches (1220 mm) minimum in length, measured perpendicular from the control wall, and 30 inches (760 mm) minimum in depth, measured from the face of the shower compartment, shall be provided. A clear floor space for toe clearance at the controls shall extend 4 inches (102 mm) minimum beyond the control end wall.

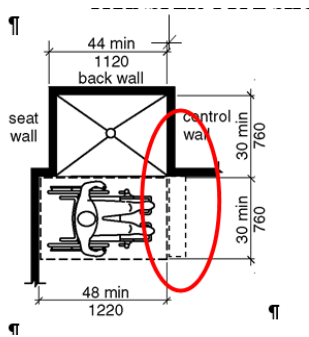
**Exceptions:**

1. A shower compartment with dimensions of 30 inches (760 mm) minimum in depth and 44 inches (1120 mm) minimum in width shall be permitted.
2. A shower door assembly shall be permitted where the assembly can be removed without removal or replacement of the surrounding walls and floor to which it is affixed.

*Note: The figure will be revised to add the 4 inch minimum control clearance to Figures (a) and (b). This would also apply if there is a wall at the toe end of the clearance.*



**FIGURE 1104.11.3.1.3.2 1104.11.3.1.3.3 (A)**  
**TRANSFER-TYPE SHOWER COMPARTMENT IN TYPE B UNITS**



**FIGURE 1104.11.3.1.3.2 ~~1104.11.3.1.3.3~~ (B)**  
**TRANSFER-TYPE SHOWER COMPARTMENT IN TYPE B UNITS EXCEPTION**

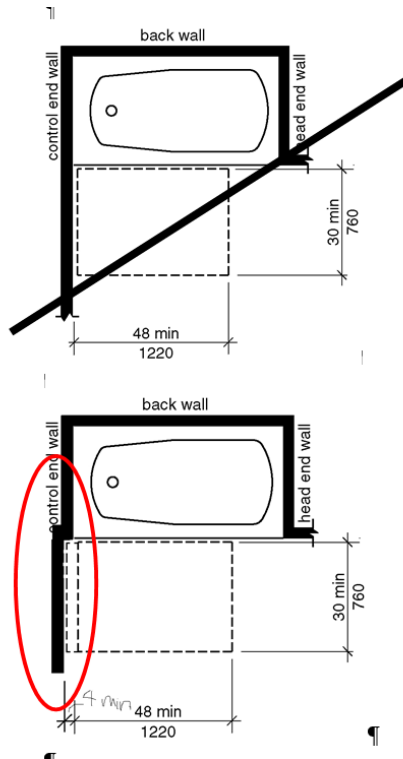
**1104.11.3.2 Option B.** *(no change)*

**1104.11.3.2.3 Bathing fixtures.** The bathing fixture shall be a bathtub complying with Section 1104.11.3.2.3.1 or a shower compartment complying with Section 1104.11.3.2.3.2.

**1104.11.3.2.3.1 Bathtub.** A transfer clearance 48 inches (1220 mm) minimum in length measured perpendicular from the control end of the bathtub, and 30 inches (760 mm) minimum in width shall be provided in front of bathtubs. A clear floor space for toe clearance at the controls shall extend 4 inches (102 mm) minimum beyond the control end wall.

*Note: Replace figure 1104.11.3.2.3.1 with the following. The figure will be revised to add the 4 inch minimum control clearance.*





**FIGURE 1104.11.3.2.3.1  
BATHROOM CLEARANCE IN TYPE B UNITS OPTION B BATHROOM**

**1104.11.3.2.3.2 Shower compartment.** A shower compartment shall comply with Section 1104.11.3.1.3.3.

---

**REASON:** Based on anthropometry, the provision of toe space past the control end of the fixture accomplishes realistic reach of the control for 90% of persons measured. The scoping change will result in all showers in Type B units meeting Sec 608 and eliminates the preference for tubs. In existing buildings “technical infeasibility” provides an exception for difficult situations.

**Notes:** Table till end of Chapter 6.

---

## 11-29 – 2021 Modification

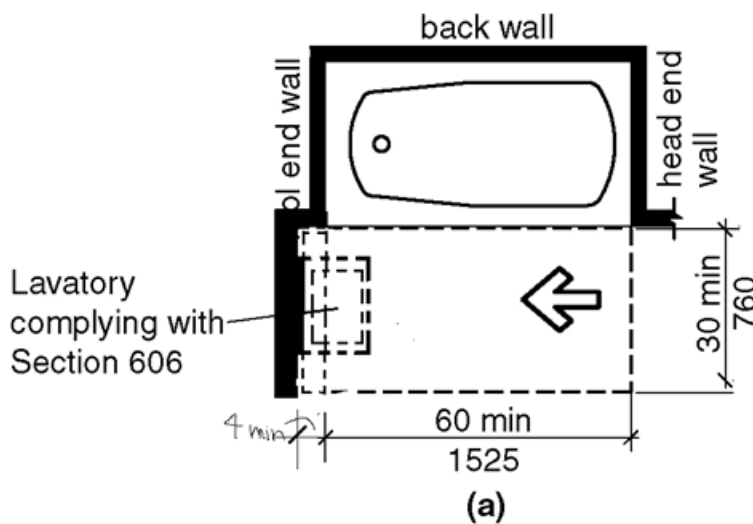
**1104.11.3.1.3, 1104.11.3.1.3.1, 1104.11.3.1.3.2, 1104.11.3.1.3.3, 1104.11.3.2.3.1;  
Figures 1104.11.3.1.3.1, 1104.11.3.1.3.2, 1104.11.3.1.3.3(A), 1104.11.3.1.3.3(B),  
1104.11.3.2.3.1**

**Proponent:** Thomas Hirsch, FAIA, Hirsch Group Architecture, representing self

**Further revise as follows:**

**1104.11.3.1.3.1 Parallel approach to bathtubs.** A transfer clearance of 60 inches (1525 mm) minimum in length and 48" (1220 mm) minimum shall be provided in front of bathtubs with a parallel approach. A clear floor space for toe clearance complying with Section 306.2 at the controls shall extend 4-6 inch (~~402~~ 152 mm) minimum beyond the control end wall. An obstruction by the control wall of 4 inches (102 mm) maximum shall be permitted.

*Note: Replace Figure 1104.11.3.1.3.1 (a) and (b) with one figure. The new figure indicates the transfer clearance and the additional 4-6 inches required for the control clearance. Also need to add 4" obstruction.*



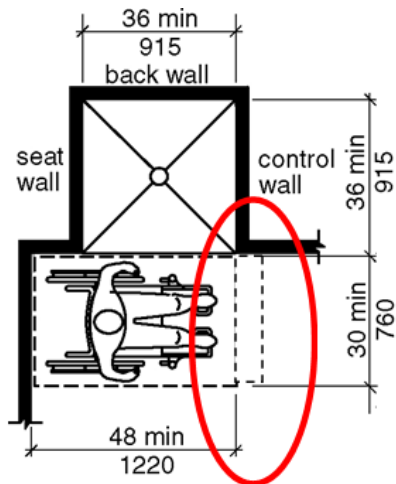
**FIGURE 1104.11.3.1.3.1  
PARALLEL APPROACH BATHTUB IN TYPE B UNITS - OPTION A BATHROOM**

**1104.11.3.1.3.2 Shower compartments.** The shower shall have dimensions of 36 inches minimum in width and 36 inches (915 mm) minimum in depth. A transfer clearance of 48 inches (1220 mm) minimum in length, measured perpendicular from the control wall, and 30 inches (760 mm) minimum in depth, measured from the face of the shower compartment, shall be provided. A clear floor space for toe clearance complying with Section 306.2 at the controls shall extend 4-6 inches (~~402~~ 152 mm) minimum beyond the control end wall.

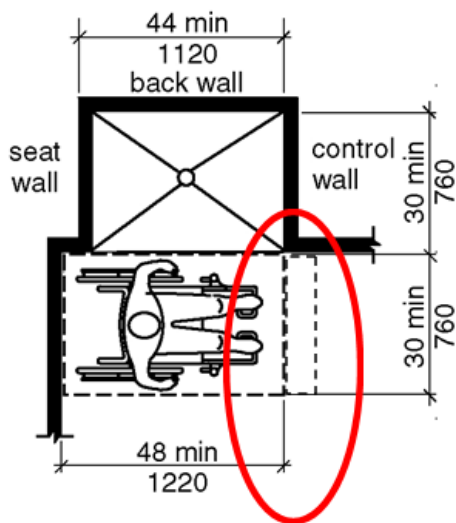
**Exceptions:**

1. A shower compartment with dimensions of 30 inches (760 mm) minimum in depth and 44 inches (1120 mm) minimum in width shall be permitted.
2. A shower door assembly shall be permitted where the assembly can be removed without removal or replacement of the surrounding walls and floor to which it is affixed.

*Note: The figure will be revised to add the 4-6 inch minimum control clearance to Figures (a) and (b). This would also apply if there is a wall at the toe end of the clearance.*



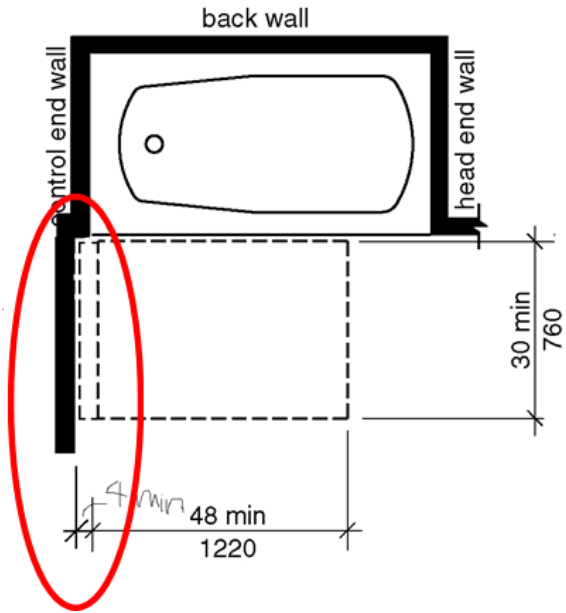
**FIGURE 1104.11.3.1.3.2 (A)**  
**TRANSFER-TYPE SHOWER COMPARTMENT IN TYPE B UNITS**



**FIGURE 1104.11.3.1.3.2 (B)**  
**TRANSFER-TYPE SHOWER COMPARTMENT IN TYPE B UNITS EXCEPTION**

**1104.11.3.2.3.1 Bathtub.** A transfer clearance 48 inches (1220 mm) minimum in length measured perpendicular from the control end of the bathtub, and 30 inches (760 mm) minimum in width shall be provided in front of bathtubs. A clear floor space for toe clearance complying with Section 306.2 at the controls shall extend 4-6 inches (102-152 mm) minimum beyond the control end wall. An obstruction by the control wall of 4 inches (102 mm) maximum shall be permitted.

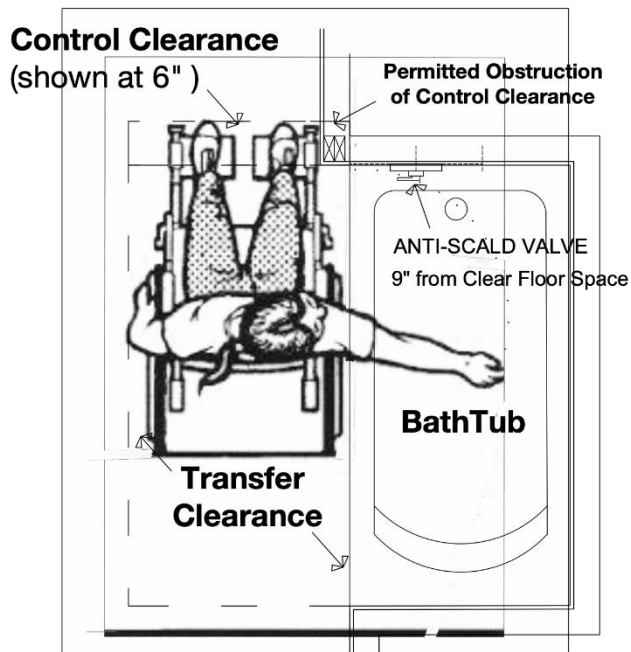
*Note: Replace figure 1104.11.3.2.3.1 with the following. The figure will be revised to add the 4-6 inch minimum control clearance. Also need to add 4" obstruction.*



**FIGURE 1104.11.3.2.3.1  
BATHROOM CLEARANCE IN TYPE B UNITS OPTION B BATHROOM**

**Reason:**

1. Conforms “toe space” with prior use of the term in Sec. 306.2.
2. Allows intrusion of wall framing without interfering with user’s toes
3. Allows for plumbing valves & piping in typical use.



*Note: Use this figure for guidance to revise figures*

**Committee Action:** Disapproval

The proposal was divided for discussion.

The proposed modification was revised to be only for bathtubs – Section 1104.11.3.1.3.1 and 1104.11.3.2.3.1 AM 5-20-4; D 25-1-3

**REPORT OF HEARING:**

**Modification (if any):**

**Committee Reason:** Based on the committee action for 06-40-21 and 06-59-21, the proponent requested consideration of only the modifications for bathtubs in Sections 1104.11.3.1.3.1 and 1104.11.3.2.3.1. The proposal was disapproved because this is a major modification to the overall configuration options currently available in Type B units with only consideration of access to bathtub controls. If improved accessibility is needed in Type B units, this needs to be a joint effort of ICC A117.1 and HUD for a total look at the requirements. For example, a turning space in the bathroom might improve accessibility much more than access to bathtub controls. In addition, this is asking for clearance at bathtub controls when plumbing controls do not have operable part of clearance requirements in Type B units at any fixture.

**1104.11.3.1.3.3-HIRSCH.doc**

<b>Report for 11-29– 2021</b>		
<b>Committee decision:</b> <i>D</i>	<b>Committee Vote at Meeting:</b> <i>25-1-3</i>	<b>Committee Vote on Ballot:</b>
<b>REPORT OF HEARING:</b>		
Modification (if any):		
Committee Reason: Based on the committee action for 06-40-21 and 06-59-21, the proponent requested consideration of only the modifications for bathtubs in Sections 1104.11.3.1.3.1 and 1104.11.3.2.3.1. The proposal was disapproved because this is a major modification to the overall configuration options currently available in Type B units with only consideration of access to bathtub controls. If improved accessibility is needed in Type B units, this needs to be a joint effort of ICC A117.1 and HUD for a total look at the requirements. For example, a turning space in the bathroom might improve accessibility much more than access to bathtub controls. In addition, this is asking for clearance at bathtub controls when plumbing controls do not have operable part of clearance requirements in Type B units at any fixture.		
<b>PUBLIC COMMENT- FIRST DRAFT:</b>		
Proponent:		
Desired Action:		
Modification:		
Reason:		
<b>Committee decision:</b> <i>AS/AM/D</i>	<b>Committee Vote at Meeting:</b>	<b>Committee Vote on Ballot:</b>
<b>REPORT OF HEARING – FIRST DRAFT</b>		
Modification (if any):		
Committee Reason:		
<b>PUBLIC COMMENT- SECOND DRAFT:</b>		
Proponent:		
Desired Action:		
Modification:		
Reason:		
<b>Committee decision:</b> <i>AS/AM/D</i>	<b>Committee Vote at Meeting:</b>	<b>Committee Vote on Ballot:</b>
<b>FINAL ACTION:</b>		
Modification (if any):		
Committee Reason:		