



# International Code Council

## ICC/NSSA Standard for the Design and Construction of Storm Shelters

### ICC 500—2020 edition Public Comment Draft – October 2019

The ICC Consensus Committee on Design and Construction of Storm Shelters has held 1 public meeting over several conference calls to develop this Public Comment Draft of the ICC 500-2020 Standard for Design and Construction of Storm Shelters. Public comment is requested on this Public Comment Draft on the strike out/underline portions only. Please show the proposed NEW or REVISED or DELETED TEXT in legislative format: ~~Line through text to be deleted.~~ Underline text to be added.

**The public comment deadline is Nov. 22, 2019.**

Go to **ICC 500** page on the **ICC website** for more information. To purchase a copy of ICC 500-2014 go to **ICC 500-2014** in the **ICC store**. A code and commentary is available at **ICC 500-2014 Code and Commentary at the ICC store**. To view a read only version of ICC 500-2014 go to **ICC 500-2014 read only**.

**ICC/NSSA Standard for the Design and Construction of  
Storm Shelters—~~2014~~2020  
(ICC 500—~~2014~~2020)**

*Note: Revisions are shown in legislative text. The **red** sections were not revised, so those sections are not subject to comment and are shown for context only. Comments received must be associated with on the of the change proposals listed in front of the revised section. Items highlighted in **yellow** are errata.*

## CHAPTER 1

# APPLICATION AND ADMINISTRATION

## SECTION 101 GENERAL

### (IS-STM 01-02-18 AM)

**101.1 Purpose.** The purpose of this standard is to establish minimum requirements to safeguard the public health, safety and general welfare relative to the design, construction and installation of *storm shelters* constructed for protection from high winds associated with tornadoes and hurricanes. This standard is intended for adoption by government agencies and organizations for use in conjunction with ~~model~~ applicable codes to achieve uniformity in the technical design and construction of *storm shelters*.

### (IS-STM 01-01-18-AFM, IS-STM 10-01-18 AM, IS-STM 01-29-18 AS)

**101.2 Scope.** This standard applies to the design, construction, installation and inspection of *storm shelters* constructed for the purpose of providing protection from high winds associated with tornadoes and hurricanes. *Storm shelters* ~~may~~ shall be constructed as either separate, detached buildings or rooms or spaces and areas within new or existing buildings. *Storm shelters* designed and constructed to this standard shall be designated as *hurricane shelters*, *tornado shelters* or combined hurricane and *tornado shelters*. Design of facilities for use as emergency shelters after the storm is outside the scope of this standard.

### (IS-STM 01-02-18 AM)

**101.3 Requirements not included.** Where requirements are not provided by this standard, the applicable provisions of the ~~construction~~ applicable codes adopted by the *authority having jurisdiction* shall apply to the *storm shelter*.

### (IS-STM 05-13-18 AFM)

**101.4 Special needs.** ~~Provisions that are necessary for persons with special needs, including any special electrical or mechanical equipment, sanitary facilities or other special features, are outside the scope of this standard.~~

**101.4 101.5 Referenced standards.** The specific year, date and editions of the standards referenced by this standard are listed in Chapter 9.

## SECTION 102 COMPLIANCE ALTERNATIVES

**102.1 Compliance alternatives.** Nothing in this standard is intended to prevent the use of designs, technologies or products as alternatives to any prescriptions in this standard, provided equivalence is demonstrated and approved by the *authority having jurisdiction*.

## SECTION 103 CONVENTIONS

**103.1 Dimensions.** All dimensions that are not stated as "maximum" or "minimum" are nominal. All dimensions are subject to conventional industry tolerances unless otherwise noted.

### (IS-STM 10-07-18 AM)

**103.2 Figures.** Unless specifically stated, figures included herein are provided for informational purposes only and are not considered part of the standard.

## SECTION 104 OCCUPANCY

(IS-STM 01-02-18 AM)

**104.1 Storm shelters within *host buildings*** ~~Rooms or spaces within other uses.~~ Where designated storm shelters are constructed as a room or space within a *host building* that will normally be occupied for other purposes, the requirements of the *applicable building code* for the occupancy of the building, or the individual rooms or spaces thereof, shall apply unless otherwise ~~stated in this standard~~ required by ICC 500.

(IS-STM 01-02-18 AM, IS-STM 05-18-18 AM)

**104.2 Dedicated facilities.** Where a facility is designed to be occupied solely as a storm shelter, the designated occupancy shall be Group A-3 as defined by the *International Building Code* for purposes of determination of applicable requirements that are not included in this standard.

### Exceptions:

1. Where the facility has ~~an occupant load~~ a *storm shelter design occupant capacity* of less than 50 persons as determined in accordance with Chapter 5, the designated occupancy shall be in accordance with Section 303 of the *International Building Code*.
2. Where the facility is a *residential storm shelter*, the designated occupancy shall be the Group R occupancy served as defined by the *International Building Code*.

**104.3 Combination storm shelters.** Where the purpose of a *storm shelter* is to provide protection from both tornadoes and hurricanes, the entire *storm shelter* shall be designed and constructed using the most restrictive requirements for each hazard.

(IS-STM 01-02-18 AM)

## SECTION 105 APPLICABLE BUILDING CODE

(IS-STM 01-02-18 AM)

**105.1 Applicable code.** Where construction of a *storm shelter* is to take place where no *applicable construction codes* are adopted, the provisions of the *International Building Code* shall apply.

(IS-STM 01-27-18 – AS, IS-STM 01-21-18 AM)

## SECTION ~~107-106~~ CONSTRUCTION SUBMITTAL DOCUMENTS

(IS-STM 01-14-18 – AM, IS-STM 01-27-18 – AS, IS-STM 01-02-18 AM, IS-STM 01-15-18 AM, IS-STM 01-21-18 AM)

**107.4 106.1 General.** ~~Where required by the authority having jurisdiction, For all storm shelters, construction submittal documents shall be prepared and submitted to the authority having jurisdiction with each permit application.~~ Such documents shall contain information as required by the *applicable building code* and this section. Storm shelter construction documents, including the design information listed in Section **106.2.1**, shall be prepared and sealed by a registered design professional.

**Exception:** The following items that are *listed* and *labeled* to indicate compliance with ICC 500 are not required to comply with this section:

1. Residential storm shelters
2. Structural components and *impact-protective systems* installed in residential storm shelters.

(IS-STM 01-27-18 – AS)

**107.2 106.2 Information required.** The following information applicable to construction and operation of the *storm shelter* shall be supplied as part of the construction documents.

(IS-STM 01-16-18 – AS, IS-STM 01-16-18 – AS, IS-STM 01-18-18 – AS, IS-STM 01-27-18 – AS, IS-STM 04-09-18-AS, IS-STM 10-05-18 AM, IS-STM 01-19-18 AM, IS-STM 01-29-18 AS, IS-STM 05-18-18 AM, IS-STM 03-11-18 AM)

**106.2.1 Design information.** For the areas of a building designed for occupancy as a *storm shelter*, the following information shall be provided within the construction documents:

1. Type of *storm shelter*: Residential or community tornado, hurricane or a combination of both.
2. Use of *community storm shelter*: Specific use, public use, or a combination of both.
- 2-3. A statement that the ~~wind~~ design conforms to the provisions of the ICC/NSSA *Standard for the Design and Construction of Storm Shelters*, with the edition year specified.
- 3-4. The *storm shelter design wind speed*,  $V$ , mph (m/s).
- 4-5. The wind exposure category (indicate all if where more than one is used).
- 5-6. The internal pressure coefficient,  $GC_{pi}$ .
- 6-7. The topographic factor,  $K_{zt}$ .
- 7-8. The directionality factor,  $K_d$ .
- 8-9. Design wind pressures and their applicable zones with dimensions needed for the specification of the components and cladding of the storm shelter envelope, psf (kN/m<sup>2</sup>).
- 8-10. A statement that the *storm shelter* has/ or has not been constructed within an area susceptible to flooding in accordance with Chapter 4 of this standard.
- 9-11. The minimum elevation of the lowest floor required by the authority having jurisdiction for the location where the storm shelter is installed; Design Flood Elevation, and the Base Flood Elevation (BFE); and the storm shelter floor elevation required in Section 401.7 for the site (if where applicable).
- 10-12. Documentation showing that components of the *storm shelter envelope* will meet the pressure and missile impact test requirements identified in Chapters 3 and 8 of this standard.
- 11-13. A floor plan drawing or image indicating location of the *storm shelter* on a site or within a building or facility; including a drawing or image indicating the entire facility.
- 12-14. A *storm shelter* section or elevation indicating the height of the *storm shelter* relative to the finished grade, finished floor, and the *host building*, where applicable.
- 13-15. The lowest *storm shelter* floor elevation and corresponding datum, except for *residential tornado shelters* outside of special flood hazard areas.
- 14-16. The maximum designed occupant load of the storm shelter occupant load design occupant capacity.
- 15-17. Calculations for the usable storm shelter floor area.
- 16-18. Calculations for the venting area (square inches) provided and locations in the storm shelter.
- 17-19. Calculations for the number of sanitation facilities for community storm shelters.
- 18-20. Minimum foundation capacity requirements including foundation thickness, steel reinforcement, and concrete cover.
- 19-21. Storm shelter installation requirements, including anchor location, minimum edge and end distance and minimum required capacity for all post-installed anchors each anchor.
- 20-22. For *hurricane shelters*, the rainfall rate of the roof primary drainage system.
- 21-23. For *hurricane shelters*, the rainfall rate of the roof secondary (overflow) drainage system where required.
- 22-24. For *hurricane shelters*, the rainwater drainage design rainfall rate for facilities subject to rain-water impoundment.

(IS-STM 01-27-18 AS, IS-STM 10-04-18 AS, IS-STM 01-29-18 AS)

**106.2.2 Enclosure.** ~~When~~ Where a *storm shelter* is to be constructed as a portion of a *host building*, the walls and floors enclosing the *storm shelter* shall be clearly indicated on the drawings.

(IS-STM 01-27-18 AS)

**106.2.3 Signage.** The type and location of signs required by this standard shall be indicated on the floor plans.

(IS-STM 01-27-18 AS, IS-STM 01-02-18 AM)

**106.2.4 Inspections.** Where any special details are utilized in the design of the structure, or where any special investigations are required in addition to those required by the *applicable building code*, the construction documents shall contain a schedule of the inspections required and the criteria for the special installation.

(IS-STM 01-27-18 AS)

~~107.2.5~~ **106.2.5 Special details.** The construction documents shall provide or include any special manufacturer's details or installation instructions for systems or equipment designed for the *storm shelter*.

(IS-STM 01-20-18- AS, IS-STM 01-27-18 – AS, IS-STM 01-29-18 AS)

~~107.2.6~~ **106.2.6 Special *Storm shelter* instructions.** The construction documents shall provide or include any special details or special instructions required for the functional operation of the *storm shelter*, such as:

- 1 Type and location of equipment and amenities required within the *storm shelter*, including water supply, sanitary facilities, fire extinguishers, batteries, flashlights, special emergency lighting equipment or any other equipment required to be installed in the *storm shelter*.
- 2 Specifications for any alarm system to be installed.
- 3 Instructions for the installation or deployment of any special protection equipment such as shutters, screens, special latching or locking of doors or windows, any equipment or switching for mechanical, electrical and plumbing equipment.

(IS-STM 01-21-18 AM)

## SECTION 107 QUALITY ASSURANCE PLAN

(IS-STM 01-27-18 AS, IS-STM 01-29-18 AS, IS-STM 01-21-18 AM)

**107.1** ~~107.3~~ **Quality assurance plan.** The construction documents for *community storm shelters* shall contain a quality assurance plan in accordance with Sections ~~107.3.4~~ 107.2 through ~~107.3.3~~ 107.4.

(IS-STM 01-27-18 AS, IS-STM 01-29-18 AS, IS-STM 01-21-18 AM)

~~107.2~~ ~~107.3.4~~ **Detailed requirements.** A quality assurance plan shall be provided for the following:

1. Roof cladding, soffits and roof framing connections.
2. Wall connections to roof and floor diaphragms and framing.
3. Roof and floor diaphragm systems, including connectors, drag struts and boundary elements.
4. Main wind-force resisting systems, including braced frames, moment frames and shear walls.
5. Main wind-force resisting system connections to the foundation.
6. Fabrication and installation of components and assemblies of the *storm shelter envelope* required to meet missile impact test requirements of Chapter 3.
7. Wall cladding and wall cladding connections.
8. Corrosion resistance or protection of exposed metal connectors providing load path continuity.
9. *Critical support systems* and connections and debris impact protection of the components and connections.
10. Foundation design.
11. Prefabricated *storm shelter* installation requirements, including anchor location and minimum required capacity for each type of anchor.
12. Prefabricated *storm shelter* minimum foundation capacity requirements.

(IS-STM 01-27-18 AS, IS-STM 01-21-18 AM)

~~107.3~~ ~~107.3.2~~ **Quality assurance plan preparation.** A quality assurance plan prepared by a registered design professional shall be provided for each main wind-force resisting system and each wind-resisting component.

The quality assurance plan shall identify the following:

1. The main wind-force resisting systems and wind-resisting components.
2. The *special inspections* and testing to be required in accordance with Section ~~106.2~~ 110.1.
3. The type and frequency of testing required.
4. The type and frequency of *special inspections* required.
5. The structural observations to be performed in accordance with Section ~~106.4~~ 111.1.
6. The required distribution, type and frequency of reports of test, inspections and structural observations.

(IS-STM 01-27-18 AS, IS-STM 10-06-18 AM, IS-STM 01-02-18 AM, IS-STM 01-21-18 AM)

~~107.4~~ ~~107.3.3~~ **Contractor Contractor's statement of responsibility.** Each contractor responsible for the construction, fabrication or installation of a main wind-force resisting system or any component listed in the quality

assurance plan shall submit a written statement of responsibility to the *authority having jurisdiction*, the responsible design professional and the owner prior to the commencement of work on the system or component. The contractor's statement of responsibility shall contain:

1. Acknowledgement of awareness of the special requirements contained in the quality assurance plan.
2. Acknowledgement that control will be exercised to obtain compliance with the construction documents.
3. Procedures for exercising control within the contractor's organization, the method and frequency of reporting and the distribution of reports.
4. Identification and qualifications of the person(s) exercising such control and their position(s) in the organization.

**Exception:** A written statement of responsibility shall not be required for the fabrication of *storm shelter* components that have been inspected and *labeled* by an *approved agency* as meeting the requirements of the *applicable building code* and this standard.

(IS-STM 01-21-18 AM)

**SECTION 108**  
**OWNER'S RESPONSIBILITY.**

(IS-STM 01-21-18 AM)

**108.1 Owner's statement of responsibility.** For each *community storm shelter* the owner shall submit to the *authority having jurisdiction* a written statement of responsibility acknowledging the owner's responsibilities regarding shelter operation and maintenance with the application for a construction permit.

(IS-STM 01-21-18 AM)

**108.2 Emergency operation plan.** For each *community storm shelter* the owner shall submit to the *authority having jurisdiction* a written emergency operations plan for the *storm shelter* prior to approval of the certificate of occupancy.

(IS-STM 01-27-18 – AS, IS-STM 01-28-18 AM)

**SECTION-109**  
**PEER REVIEW**

(IS-STM 01-27-18 AS, IS-STM 01-28-18 AM)

~~106.1.4 Peer review. A peer review shall be conducted by an independent registered design professional for compliance with the requirements of Chapters 3, 5, 6 and 7 for the following storm shelter types:~~

- ~~1. Community shelters with an occupant load greater than 50.~~
- ~~2. Storm shelters in elementary schools, secondary schools and day care facilities with an occupant load greater than 16.~~
- ~~3. Storm shelters in Risk Category IV (essential facilities) as defined in Table 1604.5 in the *International Building Code*~~

(IS-STM 01-28-18 AM) (IS-STM 05-18-18 AM) (IS-STM 10-09-18 AS)

**109.1 Storm shelters requiring peer review.** A *peer review* shall be conducted for the following *storm shelter* types:

1. Community storm shelters with a storm shelter design occupant capacity an occupant load greater than 50 or greater.
2. Storm shelters in elementary schools, secondary schools and day care facilities with a storm shelter design occupant capacity greater than 16.
3. Storm shelters in Risk Category IV (essential facilities) as defined in Table 1604.5 in the *International Building Code*.

(IS-STM 01-28-18 AM)

**109.2 Peer review.** The owner or the owner's authorized agent, other than the registered design professionals for the project, shall employ independent registered design professionals to conduct a *peer review* for compliance with the requirements of Chapters 3, 5, 6 and 7.

**Exception:** A registered design professional for the project are permitted to employ the peer reviewer where the registered design professional for the project is also the owner.

(IS-STM 01-28-18 AM)

**109.3 Peer reviewer disclosure.** The peer reviewer shall disclose to the owner or the owner's authorized agent and to the *authority having jurisdiction* and the owner or the owner's authorized agent any possible conflicts of interest, financial or otherwise.

(IS-STM 01-28-18 AM)

**109.4 Peer reviewer qualifications.** The peer reviewers shall provide written documentation to the owner or owner's authorized agent, demonstrating relevant experience and training in the specific areas of practice being peer reviewed and similar in complexity to the type of *storm shelter* design under review.

(IS-STM 01-27-18 AS, IS-STM 01-28-18 AM)

**109.5 106.1.2 Peer review report.** Where a peer review is required by Section 106.1.1, a signed and sealed report shall be submitted to the owner or owner's authorized agent and to the *authority having jurisdiction* with the construction documents identified in Section 107 prior to the issuance of a permit for construction. The report shall describe the items reviewed, provide an explanation of non-compliant issues, and recommend acceptance or rejection of the items reviewed their compliance or noncompliance with *applicable codes and standards*, and recommend acceptance or rejection of the storm shelter design or modifications to render the design acceptable.

(IS-STM 01-28-18 AM)

**109.5.1 Changes.** The registered design professional in responsible charge shall submit to the peer reviewer any changes to the design that occur after the initial peer review report and are related to the requirements of Section 109.1. If determined to be needed by the peer reviewer, an amended peer review report shall be submitted to the AHJ before such design changes are implemented.

(IS-STM 01-28-18 AM)

**109.5.2 Deferred submittal.** A *peer review* shall be required for deferred submittals that are related to the requirements of Section 109.1.

(IS-STM 01-27-18 AS)

## SECTION 106 110

### SPECIAL INSPECTIONS AND STRUCTURAL OBSERVATIONS

(IS-STM 01-27-18 AS, IS-STM 01-02-18 AM)

**106.1 General.** Construction of storm shelters and installation of all equipment shall be subject to inspections in accordance with the applicable building code.

(IS-STM 01-11-18 AS, IS-STM 01-12-18 AM, IS-STM 01-27-18 AS, IS-STM 01-02-18 AM)

**110.1 106.2 Special inspections.** *Special inspections* shall be provided in accordance with this section, in addition to those for construction and installation of materials as required by the *authority having jurisdiction* in accordance with the *applicable building code* and Section 106.3 of this standard. One statement of *special inspections* shall be permitted to apply to both *host building* and *storm shelter* construction.

(IS-STM 01-27-18 AS, IS-STM 01-02-18 AM)

**110.1.1 106.2.4 Inspection of fabricators.** Where fabrication of structural load-bearing and debris-impact-resistant components and assemblies is being performed on the premises of a fabricators shop, *special inspection* of the fabricator shall be provided.

**Exception:** Prefabricated or panelized *storm shelter* components that have been inspected and *labeled* by an *approved agency* meeting the requirements of the *applicable building code*.

(IS-STM 01-11-18 AS, IS-STM 01-27-18 AS, IS-STM 10-04-AS, IS-STM 01-29-18 AS)



**110.1.2 406.3 Special cases.** *Special inspections* shall be provided for proposed work comprised of the following:

1. Construction materials and systems that are alternatives to traditional materials and systems prescribed by the *applicable code*.
2. Unusual design and construction applications.
3. Anchors post-installed in hardened concrete and masonry, ~~when~~ where used for anchorage of *storm shelter* components forming a part of the *storm shelter* enclosure or for anchorage of the *storm shelter* structure to foundations shall be in accordance with Section ~~406.3.4~~ 110.1.2.1.

**(IS-STM 01-11-18 AS, IS-STM 01-27-18 AS, IS-STM 01-29-18 AS)**

**110.1.2.1 406.3.4 Special inspections to verify anchor installation.** A *special inspection* shall be provided to verify the post-installed anchor installation and capacity in accordance with Section ~~407.2.4-106.2.1~~. For post-installed anchorage to foundations, *special inspection* shall be provided to verify foundation adequacy in accordance with Sections ~~407.2.4-106.2.1~~ and 307.308.

**Exception:** For *residential storm shelters*, where the *authority having jurisdiction* verifies that the anchorage and, where required, the foundation complies with the requirements of the *storm shelter* design as provided in documentation required by Section ~~407-106~~, *special inspection* is permitted to be waived by the *authority having jurisdiction*.

**(IS-STM 01-27-18 AS)**

## **SECTION 111 STRUCTURAL OBSERVATIONS**

**(IS-STM 01-11-18 AS, IS-STM 01-27-18 AS, IS-STM 01-02-18 AM, IS-STM 01-29-18 AS)**

**111.1 406.4 Structural observations.** During construction of *community storm shelters*, the building owner shall employ a registered design professional to conduct visual observations of the construction of the structural system for general conformance to the approved construction documents at significant construction stages and at completion of the construction of the structural system. Structural observation shall not obviate the need for other inspections or testing required by this standard or the *applicable building code*.

Deficiencies shall be reported in writing to the owner and to the *authority having jurisdiction*. At the conclusion of the work, the registered design professional who made the structural observations shall submit to the *authority having jurisdiction* a written statement that the site visits have been made and shall identify any reported deficiencies that, to the best of the structural observer's knowledge, have not been resolved.

**(IS-STM 05-09-18 AM, IS-STM 01-25-18 AM)**

## **SECTION 108 112 DESIGN INFORMATION SIGNAGE AND LISTING AND LABELING**

**(IS-STM 05-09-18 AM, IS-STM 10-06-18 AM, IS-STM 01-22-18 AM) – relocate to 504.2)**

**108.1 Design information.** All shelters shall have a sign on or within the shelter with the name of the manufacturer or builder of the shelter and the storm type(s) and respective design wind speed(s). The sign shall remain legible and visible.

**(IS-STM 10-04-18 AS, IS-STM 01-25-18 AM)**

**112.1 408.2 Listing and labeling.** *Impact-protective systems* shall be *listed and labeled* denoting compliance with this standard. ~~Other than impact protective systems, products, materials or systems shall be labeled by an approved agency when required by the applicable code or jurisdiction.~~

**(IS-STM 01-25-18 AM)**

**112.1.1 Marking.** The following function and performance characteristics shall be provided on the *label* for each *impact protective system* tested:

1. Manufacturer's identification reference or listing number for the assembly.
2. Type of *impact protective system*, such as window assembly, door assembly, shutter assembly or louver.
3. Hazard: hurricane, tornado or both.

4. Missile weight and speed.
5. Design wind pressure.
6. Edition of ICC 500.

(IS-STM 01-13-18 AM)

**SECTION 113**  
**EVALUATION, MAINTENANCE AND REPAIRS**

(IS-STM 01-13-18 AM)

**113.1 General.** Community shelters shall be evaluated and maintained in accordance with this section and ICC 500.

(IS-STM 01-13-18 AM)

**113.2 Evaluation.** The owner or owner's representative shall evaluate the storm shelter annually and when requested by the authority having jurisdiction. The evaluation of the storm shelter shall include the following:

1. The storm shelter envelope shall be evaluated to verify that the walls and roofs appear undamaged and in good repair.
2. Impact protective systems shall be evaluated for compliance with the manufacturer's operational and maintenance requirements.

(IS-STM 01-13-18 AM)

**113.3 Maintenance and Repairs.** Storm shelters shall be maintained in an operable condition at all times. All structural and operational elements shall be repaired or replaced where damaged or found to be inoperable.

(IS-STM 01-13-18 AM)

**113.3.1 Damaged or missing components.** Storm shelters shall be maintained so that walls and roofs are intact and undamaged. Any damage to the storm shelter or its impact-protective systems that impair its functionality shall be repaired or replaced. Damaged or missing components shall be replaced with components that were originally approved within the tested assembly being repaired.

(IS-STM 01-13-18 AM)

**113.3.2 Replacement assemblies and systems.** Where it is necessary to replace certified or listed impact-protective systems, replacements shall comply with applicable ICC 500 requirements, and shall be tested and installed as required by this standard for new installations or construction.

(IS-STM 01-13-18 AM)

**113.4 Recordkeeping.** A record of the evaluations shall be maintained by the owner or owner's representative. A record of the evaluations, and any other tests, repairs or replacements, and other operations and maintenance shall be kept on the premises or other *approved* location, such as an operations manual, and should consist of all changes to the original shelter envelope or impact protective systems. Records must include the date and person conducting the evaluations and maintenance or repairs.

## CHAPTER 2

# DEFINITIONS

### SECTION 201 GENERAL

**201.1 General.** For the purposes of this standard, the terms listed in Section 202 shall have the indicated meaning.

**201.2 Undefined terms.** The terms not specifically defined in this standard or in standards referenced herein shall have ordinarily accepted meanings such as the context implies.

**(IS-STM 10-06-18 AM)**

**201.3 Interchangeability.** Words used in the present tense include the future; words stated in the masculine gender include the feminine and neuter; the singular number includes the plural and the plural, the singular.

### SECTION 202 DEFINITIONS

**(IS-STM 02-10-18 AM)**

**ALCOVE STORM SHELTER ENTRY SYSTEM.** See the definition of “Entry System, Alcove or Baffled Storm Shelter.”

**(IS-STM 01-02-18 AM, IS-STM 02-10-18 AM)**

**APPLICABLE CODE.** The regulation for design and building construction of buildings and structures adopted by the authority having jurisdiction over the construction of the specific storm shelter.

**(IS-STM 02-01-18 AM)**

**APPROVED AGENCY.** An established and recognized agency that is regularly engaged in conducting tests, furnishing inspection services or furnishing product certification, where such agency has been approved by the building official.

**AREAS OF CONCENTRATED FURNISHINGS.** The areas of a *storm shelter* with furniture or fixtures that cannot be moved easily, including areas such as bathrooms, locker rooms and rooms with fixed seating or fixed tables.

**AREAS OF UNCONCENTRATED FURNISHINGS.** The areas of a *storm shelter* with furniture or fixtures that can be moved easily, including areas such as classrooms and offices.

**AREAS OF OPEN PLAN FURNISHINGS.** The areas of a *storm shelter* that are generally free of furniture or fixtures that cannot be moved easily and of interior partitions or other features that block movement through, or otherwise subdivide, the space.

**AUTHORITY HAVING JURISDICTION.** The organization, political subdivision, office or individual charged with the responsibility for administering and enforcing the provisions of this standard.

**(IS-STM 02-10-18 AM)**

**BAFFLED STORM SHELTER ENTRY SYSTEM.** See the definition of “Entry System, Alcove or Baffled Storm Shelter.”

**(IS-STM 04-08-18 AS)**

**COASTAL A ZONE.** Area within a special *flood hazard area*, landward of a V zone or landward of an open coast without mapped *coastal high-hazard areas*. In a coastal A zone, the principal source of flooding must be

astronomical tides, storm surges, seiches or tsunamis, not riverine flooding. During the base flood conditions, the potential for breaking wave height shall be greater than or equal to 1-1/2 feet (457 mm). The inland limit of the coastal A zone is one of the following:

1. The Limit of Moderate Wave Action if delineated on a FIRM.
2. Designated by the authority having jurisdiction.

**(IS-STM 04-08-18 AS)**

**COASTAL HIGH-HAZARD AREA.** Area within the special *flood hazard area* extending from offshore to the inland limit of a primary dune along an open coast and any other area that is subject to high-velocity wave action from storms or seismic sources, and shown on a Flood Insurance Rate Map (FIRM) or other flood hazard map as velocity Zone V, VO, VE or V1-30.

**COLLAPSE HAZARDS.** See “Hazards, Collapse.”

**(IS-STM 02-02-18 AS, IS-STM 07-01-18 AM)**

**CRITICAL SUPPORT SYSTEMS, STORM SHELTER.** Structures, Systems and components required to ensure the health, safety and well-being of shelter occupants. Critical support systems include, ~~but are not limited to,~~ potable and waste water systems, ~~electrical~~ emergency and standby power ~~and lighting~~ systems, ~~life safety systems~~ and HVAC ventilation systems.

**(IS-STM 05-18-18 AM)**

**DESIGN OCCUPANT CAPACITY, STORM SHELTER.** The number of occupants for which the storm shelter is designed.

**(IS-STM 02-10-18 AM)**

**DESIGN WIND PRESSURE.** The wind pressure on a specific location of the storm shelter envelope, as determined in accordance with Section 304, Wind Loads, which controls the design of components and cladding (C & C) of the storm shelter envelope or the main wind-force resisting system (MWFRS) for the storm shelter.

**(IS-STM 02-10-18 AM, IS-STM 03-11-18 AM)**

**STORM SHELTER DESIGN WIND SPEED (V), STORM SHELTER.** The maximum wind speed for which the storm shelter has been designed. Values shall be the nominal 3-second gust wind speed in miles per hour (~~km/h~~ m/s) at 33 feet (10 m) above ground for open terrain (Exposure C).

**(IS-STM 02-10-18 AM)**

**SHELTER ENTRY SYSTEM, ALCOVE OR BAFFLED STORM SHELTER.** An entry system that uses walls and passageways to allow access and egress to the storm shelter interior while providing shielding from wind-borne debris in accordance with Section ~~306.5~~ **306.4.4**.

**(IS-STM 02-10-18 AM)**

**SHELTER ENTRY SYSTEM, BAFFLED** See the definition of “Shelter Entry System, Alcove.”

**(IS-STM 02-10-18 AM)**

**FIRE BARRIER.** A fire-resistance-rated vertical wall assembly of materials designed to restrict the spread of fire in which ~~openings are protected~~ continuity is maintained.

**(IS-STM 04-09-18 AS)**

**FLOOD ELEVATION STUDY.** An examination, evaluation and determination of flood hazard and, where appropriate, corresponding water surface elevations, or an examination, evaluation and determination of storm surge inundation, including coastal wave effects, associated with the maximum intensity hurricane.

**(IS-STM 04-09-18 AS)**

**FLOOD HAZARD AREA.** The greater of the following two areas:

1. The area in a floodplain subject to a 1-percent or greater chance of flooding in any year.
2. The area designated as a flood hazard area on a community's flood hazard map, or otherwise legally designated.

(IS-STM 02-10-18 AM)

**FURNISHINGS.** See AREAS OF CONCENTRATED FURNISHINGS, AREAS OF UNCONCENTRATED FURNISHINGS and AREAS OF OPEN PLAN FURNISHINGS

(IS-STM 10-05-18 AM, IS-STM 02-10-18 AM, IS-STM 03-12-18 AM)

**HAZARDS.**

**Coastal.** See definition for Coastal High-Hazard Area.

**Collapse Falling debris.** Debris from wind damage to adjacent, taller structures that could fall onto the shelter. Exterior components, cladding, and appurtenances, such as parapet walls, masonry cladding, or rooftop equipment, that could fall onto the roof of a storm shelter from wind damage to adjacent, taller buildings or taller sections of a host building.

**Flood.** See definition for Flood Hazard Area.

**Laydown.** Nearby structures other than buildings, such as self-supporting towers, poles or large trees, that could fall onto the roof of a storm shelter, if the shelter is within the laydown radius of the structure.

**Rollover.** Vehicles and small buildings, such as temporary classroom buildings, that could roll over due to extreme winds and impact the shelter.

(IS-STM 02-10-18 AM)

**HORIZONTAL ASSEMBLY.** A fire-resistance-rated floor or roof assembly of materials designed to restrict the spread of fire in which continuity is maintained.

**HOST BUILDING.** A building that is not designed or constructed as a *storm shelter* that totally or partially encloses, or is connected to, a *storm shelter*.

(IS-STM 02-10-18 AM)

**HURRICANE SHELTER.** See the definition for Storm Shelter.

(IS-STM 02-08-18 AM, IS-STM 08-16-18 AS (deleted from Section 802.2), IS-STM 08-17-18 AS, IS-STM 02-10-18 AM)

**IMPACT-PROTECTIVE SYSTEM.** A system or device, subject to pressure and impact testing as detailed in this standard, installed to protect an opening in a roof, wall or floor of the storm shelter envelope that is capable of withstanding pressure and impact testing as detailed in this standard. such as door assemblies, window assemblies and other devices to protect openings.

(IS-STM 02-10-18 AM, IS-STM 08-07-18 AM-CC)

**~~INTERIOR SURFACE OF THE SHELTER COMPONENT.~~** ~~The inside surface of any structural component of the storm shelter envelope.~~

**LABEL.** An identification applied on a product by the manufacturer that contains the name of the manufacturer, the function and performance characteristics of the product or material, and the name and identification of an *approved agency* and that indicates that the representative sample of the product or material has been tested and evaluated by an *approved agency*.

(IS-STM 02-04-18 AS) – this section already had the proposed text.

**LABELED.** Equipment, materials or products to which has been affixed a *label*, seal, symbol or other identifying mark of a nationally recognized testing laboratory, *approved agency* or other organization concerned with product evaluation that maintains periodic inspection of the production of the above-labeled items and whose labeling indicates either that the equipment, material or product meets identified standards or has been tested and found suitable for a specified purpose.

**LAYDOWN HAZARDS.** See “Hazards, Laydown.”

(IS-STM 05-06-18 AM)

**LISTED.** Equipment, materials, products or services included in a list published by an organization acceptable to the *building* official and concerned with evaluation of products or services that maintains periodic inspection of production of listed equipment or materials or periodic evaluation of services and whose listing states either that the equipment, material, product or service meets identified standards or has been tested and found suitable for a specified purpose.

(IS-STM 04-14-18 AS)

~~**LOCAL EMERGENCY PLANNING COMMITTEE.** A group of citizens defined by the community as having responsibility for local emergency planning. The committee shall be recognized by the governing body as having this responsibility.~~

**NATURAL VENTILATION.** Passive ventilation, not requiring a power source, resulting from convection of heated air, movement of inside air and movement of outside air over and around the *storm shelter* resulting in air exchange through vent openings.

(IS-STM 02-10-18 AM) (IS-STM 05-18-18 AM)

~~**STORM SHELTER OCCUPANT LOAD.** The occupant load intended for a room or space when that space is in use as a *storm shelter*.~~

(IS-STM 07-13-18 AM, IS-STM 02-10-18 AM)

**OCCUPANT SUPPORT AREAS.** The areas required to ensure the health, safety and well-being of occupants. *Occupant support areas* are areas that serve the *storm shelter* and include, but are not limited to, *storm shelter* management, food preparation, water and food storage, electrical and mechanical rooms, toilet and other sanitation rooms and first-aid stations.

(IS-STM 05-03-18 AM, IS-STM 02-10-18 AM)

**OCCUPIED STORM SHELTER AREAS.** The designated *storm shelter* area **area** within the *storm shelter envelope* and excluding *occupant support areas*.

**ON-SITE.** Either inside, immediately adjacent to, or on the same site as the designated *storm shelter* facility, and under the control of the owner or lawful tenant.

(IS-STM 01-28-18 AM, IS-STM 10-06-18 AM)

~~**PEER REVIEW.** A review of the *storm shelter* in accordance with Section 106.1.1 by a an independent registered design professional(s) independent from the registered design professional(s) in responsible charge of the *storm shelter* design. The peer review includes checking the construction documents, calculations and quality assurance plan for the *storm shelter* design.~~

(IS-STM 02-10-18 AM)

~~**PROTECTED OCCUPANT AREA.** The portions of the *storm shelter* area that are protected from intrusion of storm debris by *alcove or baffled entry systems* in accordance with Section 804.9.7.~~

(IS-STM 02-10-18 AM)

~~**REBOUND IMPACT.** The rebound impact by a test missile, or fragments thereof, on a portion of the *storm shelter* protective envelope after the test missile has impacted another surface of the *storm shelter* protective envelope.~~

(IS-STM 08-19-18 AM)

**ROLLING DOOR ASSEMBLY.** A vertically operating coiling door made of a curtain consisting of formed metal slats interlocking together, supported by a barrel assembly at the top of the opening, operating by means of angles acting as door guides at the jambs.

(IS-STM 03-12-18 AM CCC)

**ROLLOVER HAZARDS.** See "Hazards, Rollover."

(IS-STM 08-19-18 AM)

**SECTIONAL DOOR ASSEMBLY.** A vertically operating door made of two or more horizontal sections hinged together, operating by means of tracks and track rollers at the jambs.

**(IS-STM 02-08-18 AM, IS-STM 02-10-18 AM)**

**SHELTER ENVELOPE, STORM.** The ~~protective~~ impact and pressure resistant roofs, walls and floors and the impact-protective systems that doors and other protected openings that are designed to meet the requirements of Chapter 3 to provide protection to occupants during a severe windstorm and meet the requirements of Chapter 3.

**SPECIAL INSPECTION.** Inspection of construction requiring the expertise of an approved *special inspector* in order to ensure compliance with this standard and the approved construction documents.

**SPECIAL INSPECTOR.** A qualified person employed or retained by an *approved agency* and approved by the building official as having the competence necessary to inspect a particular type of construction requiring *special inspection*.

**(IS-STM 08-16-18 AS) (relocated from 802.2)**

**SPECIMEN.** The entire assembled unit submitted for testing, including but not limited to anchorage devices and structure to which the product is to be mounted.

**(IS-STM 10-06-18 AM, IS-STM 10-03-18 AM, IS-STM 02-10-18 AM, IS-STM 05-18-18 AM)**

**STORM SHELTER.** A building, structure or portion(s) thereof, constructed in accordance with this standard, designated for use during a severe wind storm event such as a hurricane or tornado.

**Community Storm Shelter.** Any *storm shelter* not defined as a *residential storm shelter*. This includes both storm shelters intended for use by the general public and storm shelters intended for use by building occupants.

**Residential Storm Shelter.** A *storm shelter* serving occupants of dwelling units and having an **a storm shelter** an occupant-load a *storm shelter design occupant capacity* not exceeding 16 persons.

**(IS-STM 08-16-18 AS) (relocated from 802.2)**

**TEST CHAMBER.** An airtight enclosure of sufficient depth to allow unobstructed deflection of the *specimen* during pressure cycling, including ports for air supply and removal, and equipped with instruments to measure test pressure differentials.

**(IS-STM 02-09-18 AM)**

**TEST LABORATORY.** A testing agency certified in accordance with ISO/IEC 17025 to conduct missile impact and pressure testing required in Chapter 8.

**(IS-STM 02-10-18 AM)**

**TORNADO SHELTER.** See the definition for Storm Shelter.

**(IS-STM 05-03-18 AM, IS-STM 02-10-18 AM, IS-STM 05-18-18 AM)**

**USABLE STORM SHELTER FLOOR AREAS.** The portions of the floor area within the *storm shelter envelope* not including *occupant support areas*, used to determine the maximum *storm shelter design occupant capacity* of the *storm shelter*.

**(IS-STM 02-10-18 AM)**

**WIND PRESSURE.** See the definition for Design Wind Pressure.

**(IS-STM 02-10-18 AM)**

**WIND SPEED.** See the definition for Design Wind Speed, Storm Shelter.

**(IS-STM 02-10-18 AM) (IS-STM 03-11-18 AM)**

## **SECTION 203** **SYMBOLS AND NOMENCLATURE**

APC - Atmospheric pressure change

ASD – allowable stress design

C & C – components and cladding

$GC_{pi}$  – internal pressure coefficient

LRFD – load and resistance factor design

$K_d$  – directionality factor

$K_{zt}$  – topographic factor

MWFRS – main wind-force resisting system

V- Design wind speed

W – wind loads.



(IS-STM 03-01-18 AM)

## CHAPTER 3

# STRUCTURAL DESIGN AND TESTING CRITERIA

### SECTION 301 GENERAL

(IS-STM 03-01-18 AM, IS-STM 01-02-18 AM)

**301.1 Scope.** The requirements of this chapter shall govern the structural design and testing criteria of storm shelters. Loads and load combinations shall be determined in accordance with ASCE 7 unless otherwise noted.

**301.2 General design requirements.** ~~Structural elements of the Storm shelters shall be designed in accordance with the appropriate material design standard specified referenced in the applicable building code to sustain resist the loads prescribed in ASCE 7, as modified by this chapter, and combined in accordance with the load combinations of ASCE 7, as modified by Section 302.~~

(IS-STM 03-01-18 AM, IS-STM 01-02-18 AM)

**301.1.1 Design or testing.** ~~Where the strength requirements cannot be determined by engineering calculations in accordance with appropriate material design standards referenced by the applicable building code, roof and wall assemblies shall meet the pressure requirements of Section 805.~~

(IS-STM 03-01-18 AM, IS-STM 03-02-18 AM)

**301.1.2 Anchor calculations—doors, windows and shutters.** ~~Where anchorage of door, window or shutter framing to the shelter structure is required by means other than those provided in the manufacturer's listing or installation instructions in accordance with Section 107, alternate anchorage shall be designed for pull-out and shear and the anchor placement detailed in accordance with accepted engineering practice. The alternate anchorage details and calculations shall be provided as part of the construction documents.~~

(IS-STM 03-01-18 AM)

**301.3 General testing requirements.** Where the capacity of storm shelter envelope components cannot be determined by engineering calculations in accordance with Section 301.2, it shall be determined through testing in accordance with Section 306.

### SECTION 302 LOAD COMBINATIONS

(IS-STM 02-10-18 AM)

**302.1 Strength design.** For strength design or load and resistance factor design (LRFD), use the load combinations stated in ASCE 7, Section 2.3 with wind loads,  $W_1$ , determined in accordance with Section 304 of this standard. Exception 1 to ASCE 7 Section 2.3.2 shall not apply.

(IS-STM 02-10-18 AM)

**302.2 Allowable stress design.** For allowable stress design (ASD), use the load combinations stated in ASCE 7, Section 2.4 with wind loads,  $W_1$ , determined in accordance with Section 304 of this standard.

### SECTION 303 LOADS

**303.1 Rain loads.** Rain loads shall be determined in accordance with ASCE 7. Rainfall rates for *hurricane shelter* roofs shall meet the following requirements:

(IS-STM 03-04-18-AFM)

**303.1.1. Rainfall rate.** The rainfall rate shall be determined by adding 6 inches (152.4 mm) of rainfall per hour to the 100-year, 1-hour rainfall rate. The 100-year, 1 hour rainfall rate shall be determined from Figure 303-2 303.1.1 or from approved local weather data.



For SI: 1 inch = 25.4 mm.

**(IS-STM 03-04-18-AFM)**

**FIGURE 303-2 303.1.1**

**100-YEAR, 1-HOUR RAINFALL (INCHES), EASTERN/CENTRAL UNITED STATES**

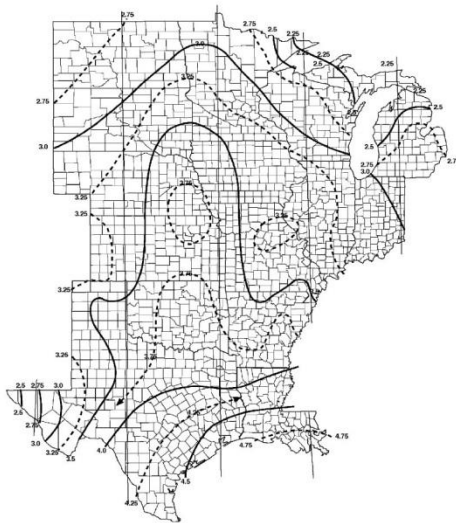

For SI: 1 inch = 25.4 mm.

**(IS-STM 03-04-18-AFM)**

**FIGURE 303-2 303.1.1—continued**

**100-YEAR, 1-HOUR RAINFALL (INCHES), CENTRAL UNITED STATES**

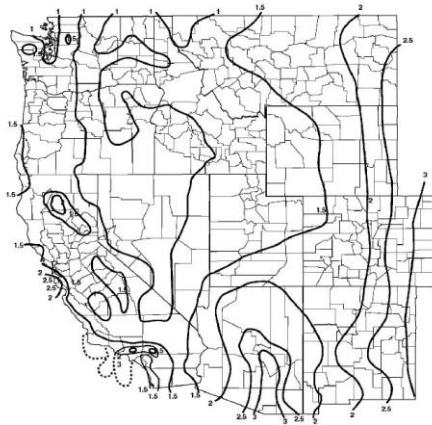

For SI: 1 inch = 25.4 mm.  
 Source: National Weather Service, National Oceanic and Atmospheric Administration, Washington, DC.

**(IS-STM 03-04-18-AFM)**  
**FIGURE 303.1.1—continued**  
**100-YEAR, 1-HOUR RAINFALL (INCHES), WESTERN UNITED STATES**

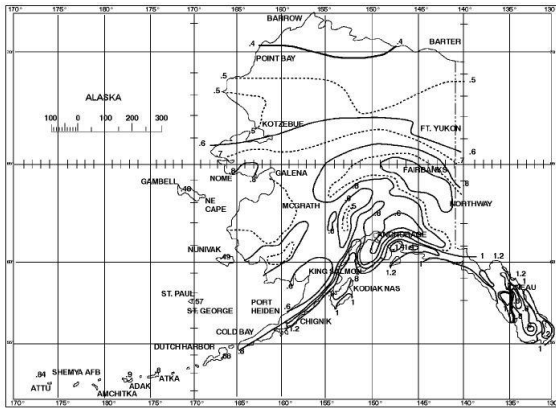

For SI: 1 inch = 25.4 mm.  
 Source: National Weather Service, National Oceanic and Atmospheric Administration, Washington, DC.

**(IS-STM 03-04-18-AFM)**  
**FIGURE 303.1.1—continued**  
**100-YEAR, 1-HOUR RAINFALL (INCHES), ALASKA**

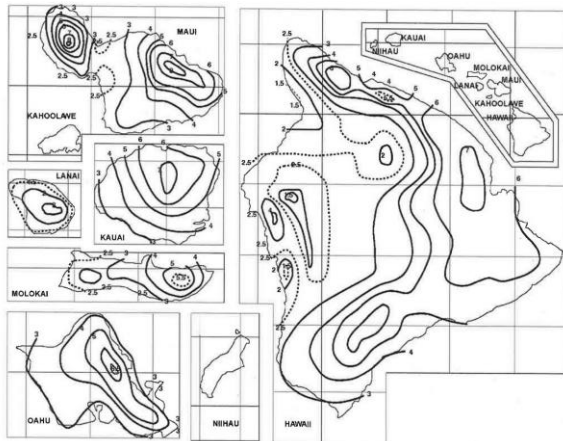

(IS-STM 03-04-18-AFM)

**FIGURE 303.1.1—continued**

**100-YEAR, 1-HOUR RAINFALL (INCHES), HAWAII**

**303.2 Roof live loads.** *Storm shelter* roofs shall be designed for minimum live loads specified in ASCE 7, but not less than the following:

*Tornado shelters:* 100 pounds per square foot (4.8 kN/m<sup>2</sup>)

*Hurricane shelters:* 50 pounds per square foot (2.4 kN/m<sup>2</sup>)

(IS-STM 03-12-18 AM)

**303.2.1-Wheel loads.** Storm shelters subject to vehicle loads shall be designed for vehicle loads in accordance with the International Building Code Section 1607, the International Residential Code Section R301.5, or ASCE 7 Section 4.10 as applicable.

**303.3 Hydrostatic loads.** Underground portions of *storm shelters* shall be designed for buoyancy forces and hydrostatic loads assuming that the ground water level is at the surface of the ground at the entrance to the *storm shelter*, unless adequate drainage is available to justify designing for a lower ground water level.

(IS-STM 04-09-18-AS, IS-STM 03-29-18 AS)

**303.4 Flood loads.** Flood loads shall be determined in accordance with ASCE 7. ~~The design using a flood elevation shall equal not less than the minimum floor elevation as specified required in Section 402.7 404 of this standard.~~

## **SECTION 304 WIND LOADS**

(IS-STM 02-10-18 AM, IS-STM 03-11-18 AM)

**304.1 General.** Wind loads, *W*, and *design wind pressure* shall be determined using in accordance with ASCE 7, Chapters 26 through 31, except as modified by this section.

(IS-STM 03-28-18 AS, IS-STM 03-11-18 AM)

**304.2 Design wind speed.** For *tornado shelters*, the *storm shelter design wind speed*, *V*, shall be in accordance with Figure 304.2(1). For *hurricane shelters*, the *storm shelter design wind speed* shall be in accordance with Figure 304.2(2).

(IS-STM 03-08-18 AM, IS-STM 03-28-18 AS, IS-STM 03-11-18 AM)

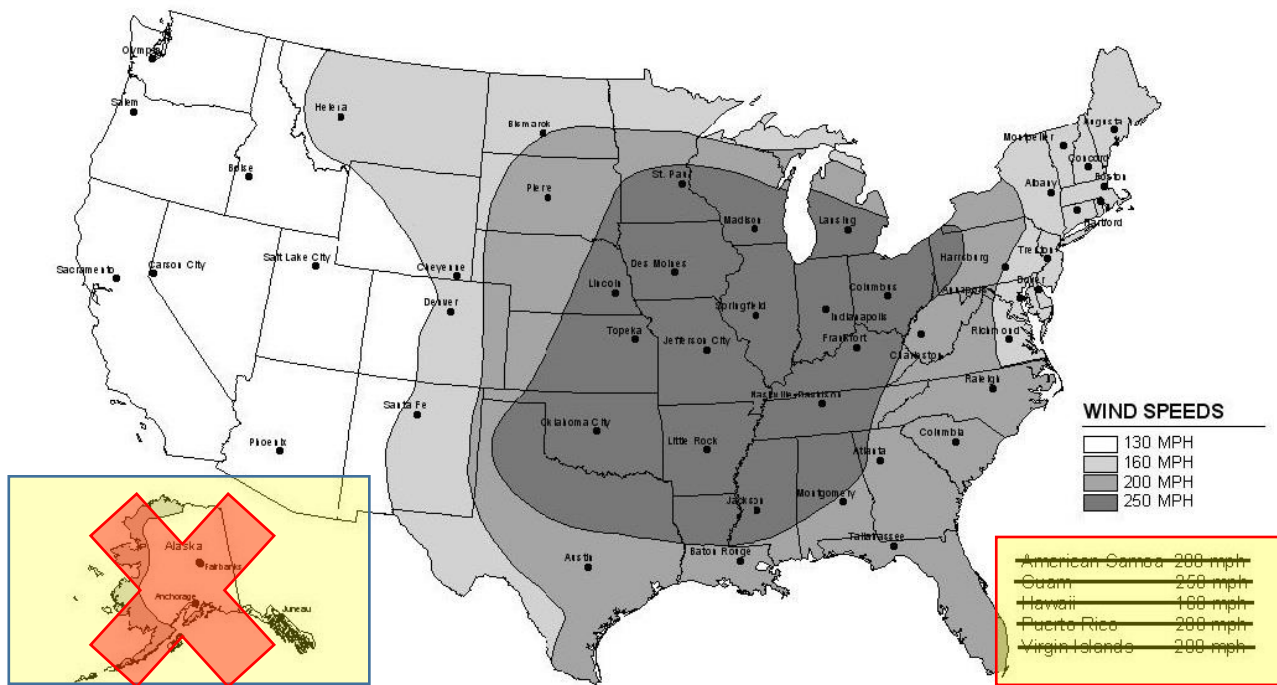

- Notes:
1. Values are nominal three-second gust wind speeds in miles per hour at 33 feet above ground for Exposure Category C.
  2. Multiply miles per hour by 0.447 to obtain meters per second.

Figure 304.2(1) STORM SHELTER DESIGN WIND SPEEDS,  $V$ , FOR TORNADOES  
 (IS-STM 03-09-18 AM) revised figures for hurricane maps

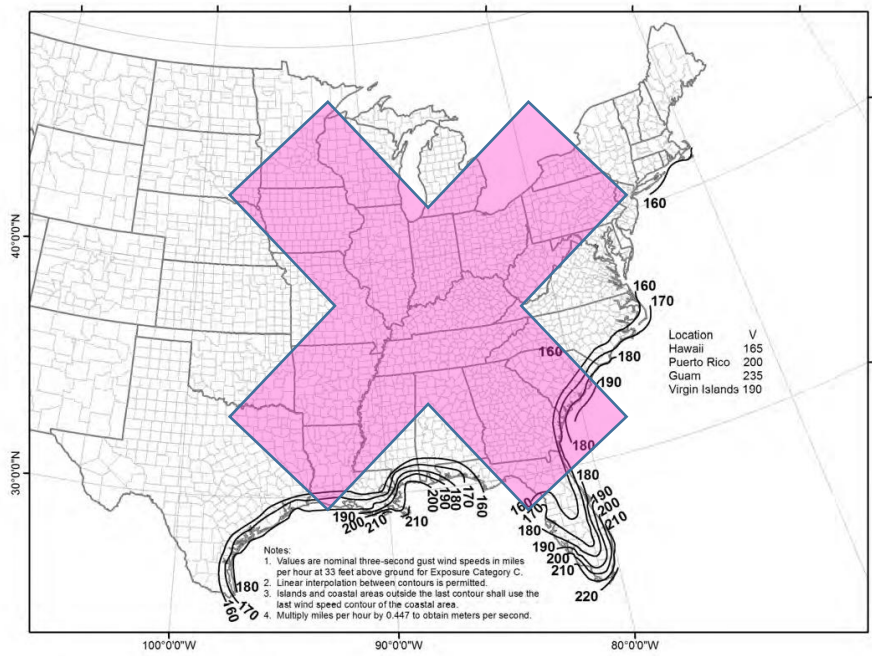

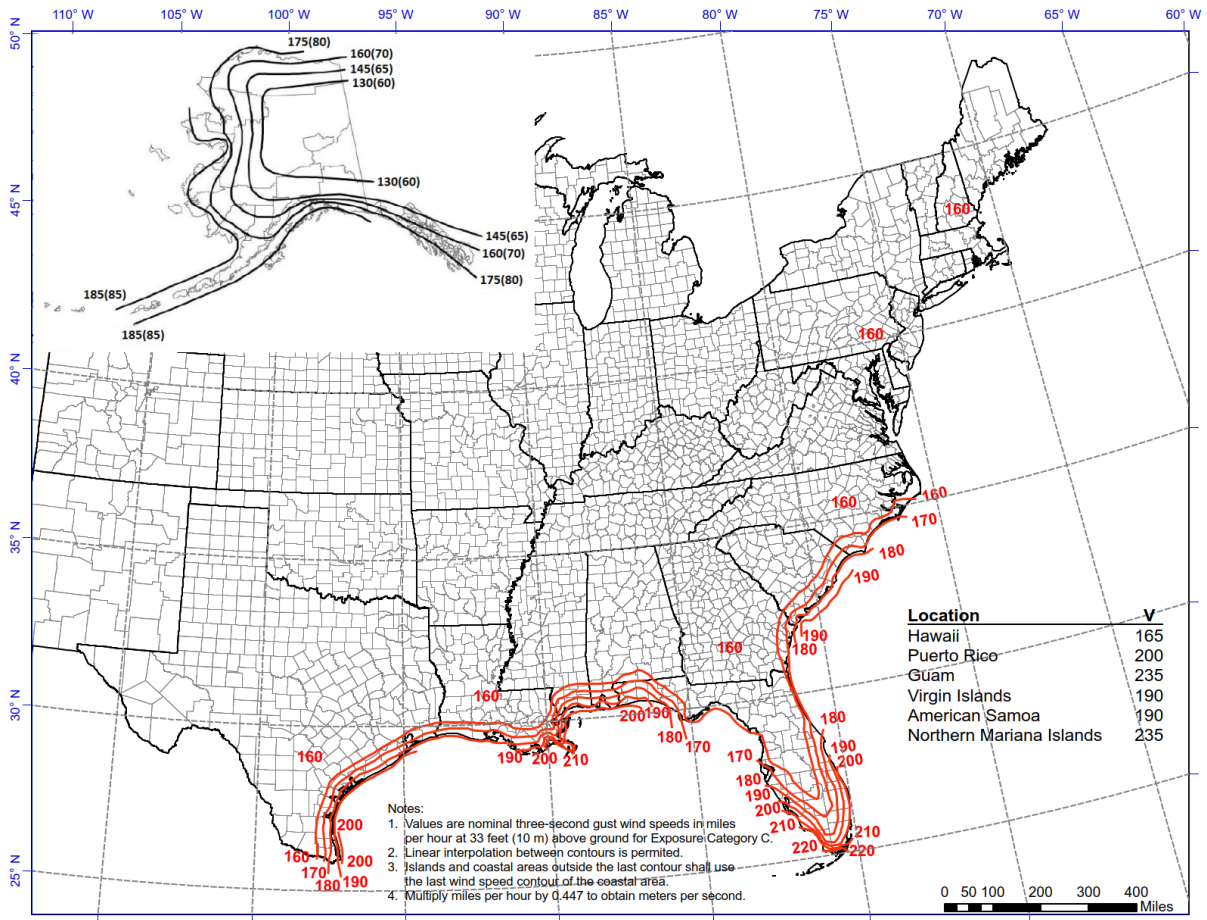

(IS-STM 03-28-18 AS) (IS-STM 03-11-18 AM)  
 FIGURE 304.2(2)  
**STORM SHELTER DESIGN WIND SPEEDS,  $V$ , FOR HURRICANES**

(IS-STM 03-09-18 AM) revised figures for hurricane maps

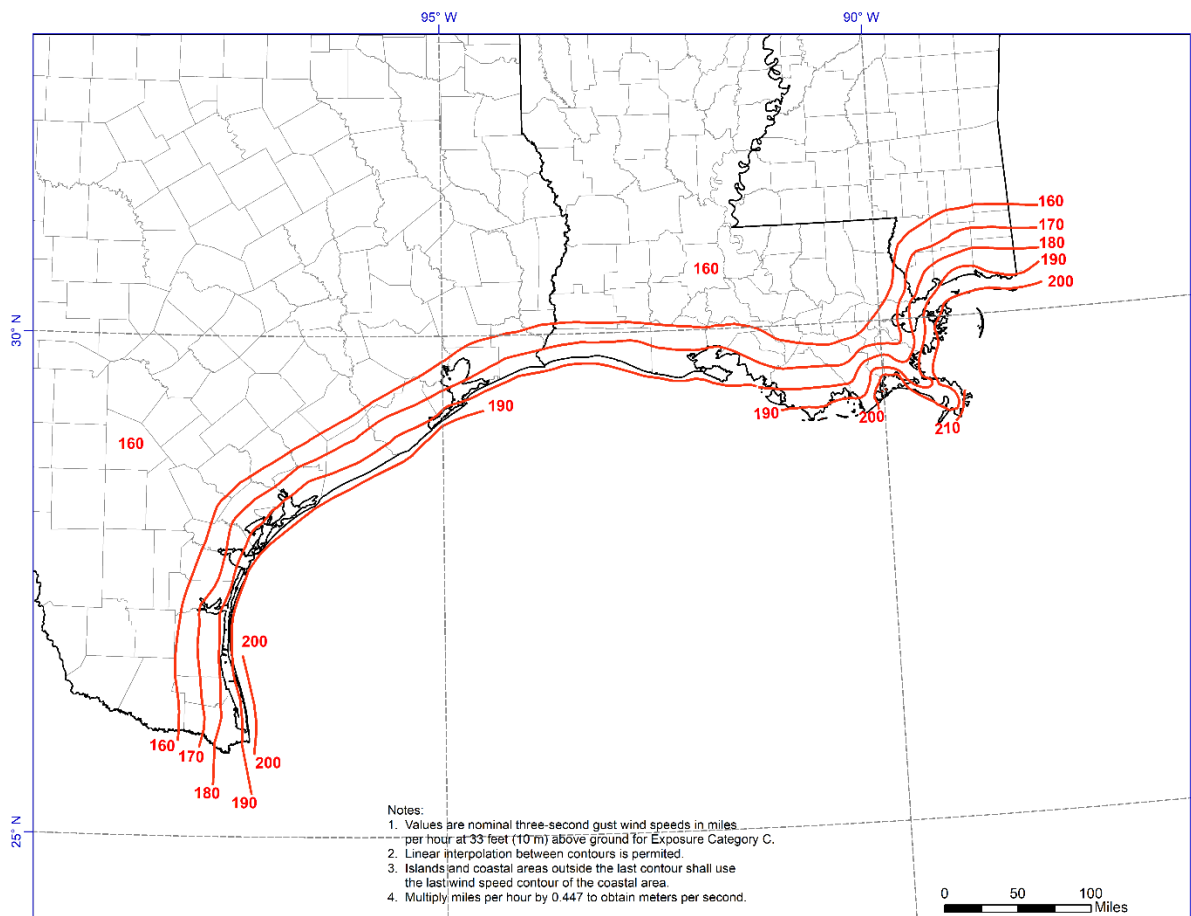
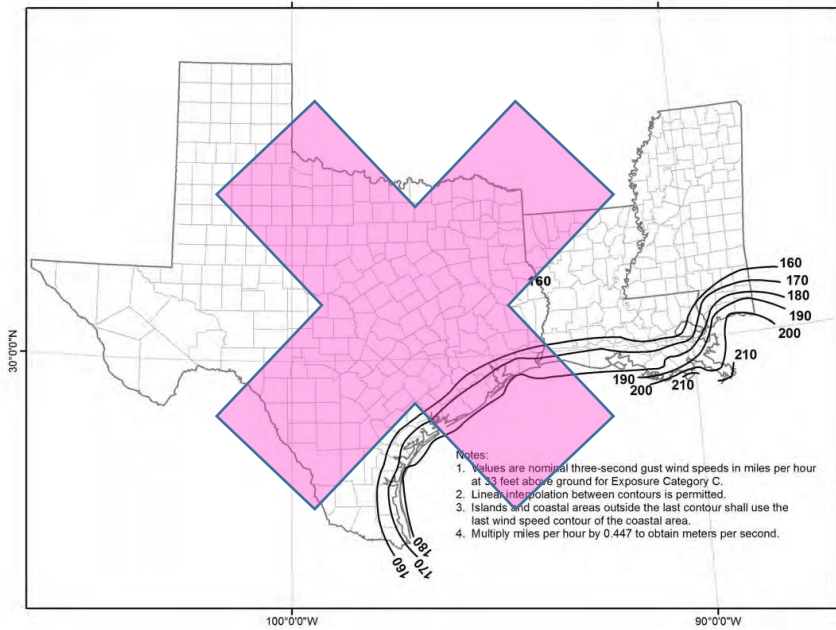

(IS-STM 03-28-18 AS) (IS-STM 03-11-18 AM)  
**STORM SHELTER DESIGN WIND SPEEDS,  $V_s$**  FOR HURRICANES—WESTERN GULF OF MEXICO

(IS-STM 03-09-18 AM) revised figures for hurricane maps

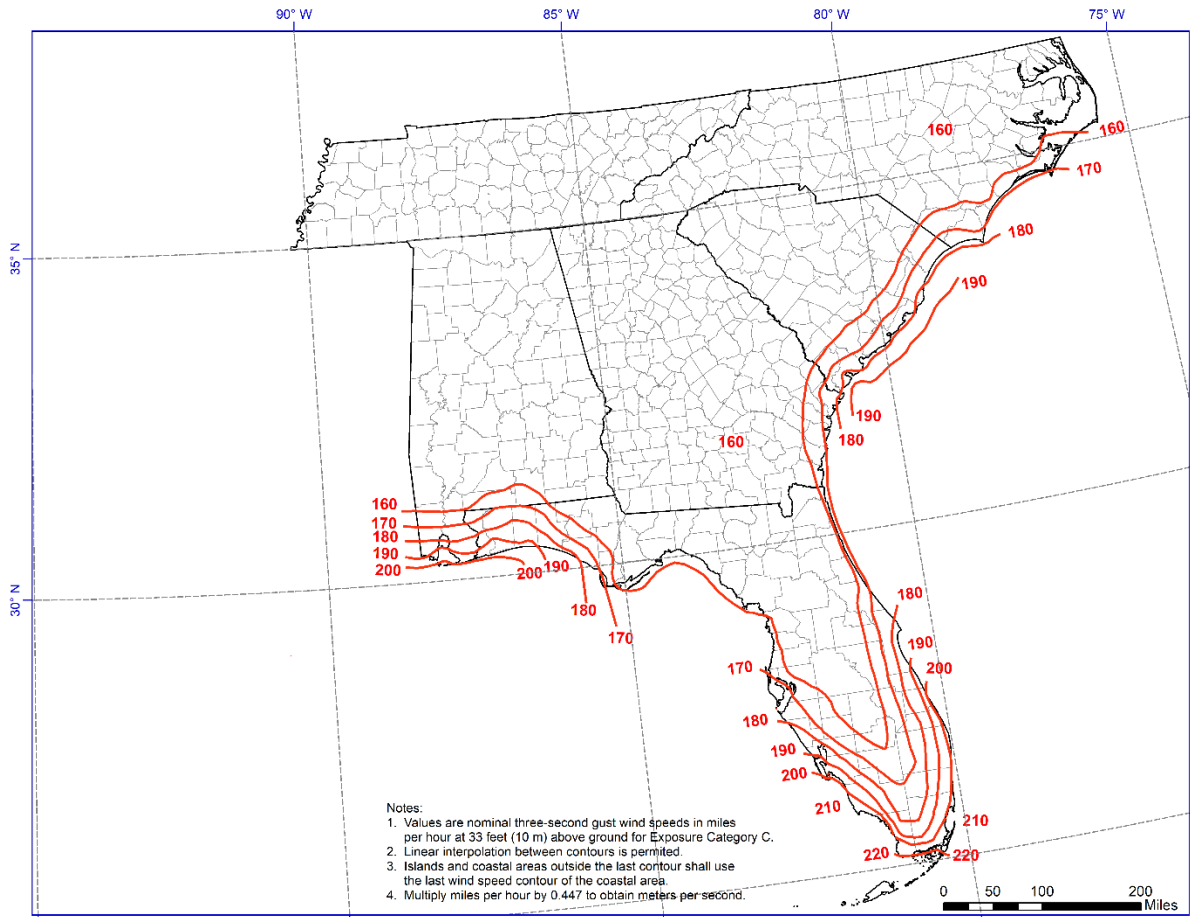
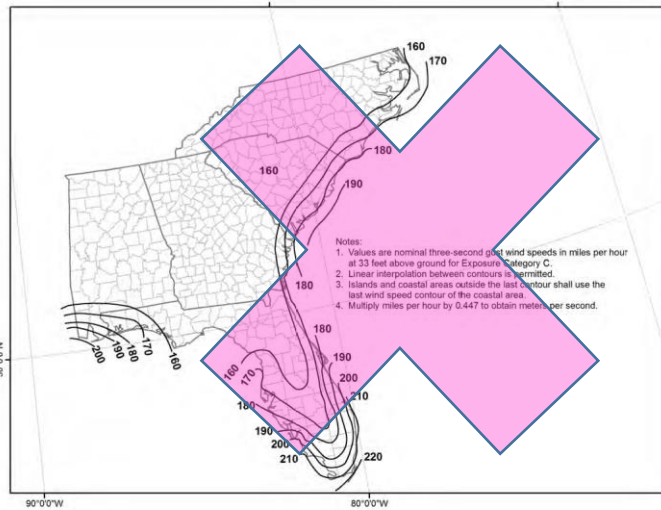

(IS-STM 03-28-18 AS) (IS-STM 03-11-18 AM)

FIGURE 304.2(2)—continued

**STORM SHELTER DESIGN WIND SPEEDS,  $V_s$ , FOR HURRICANES—EASTERN GULF OF MEXICO AND SOUTHERN ATLANTIC**

(IS-STM 03-09-18 AM) revised figures for hurricane maps



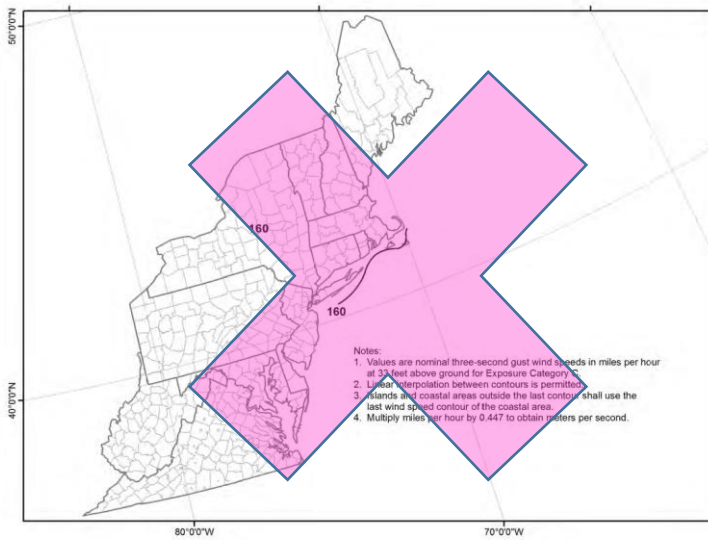

(IS-STM 03-28-18 AS) (IS-STM 03-11-18 AM)

**FIGURE 304.2(2)—continued**

**SHELTER DESIGN WIND SPEEDS<sub>2</sub> FOR HURRICANES—MID-NORTHERN ATLANTIC**

(IS-STM 03-09-18 AM) *new figure for Alaska*

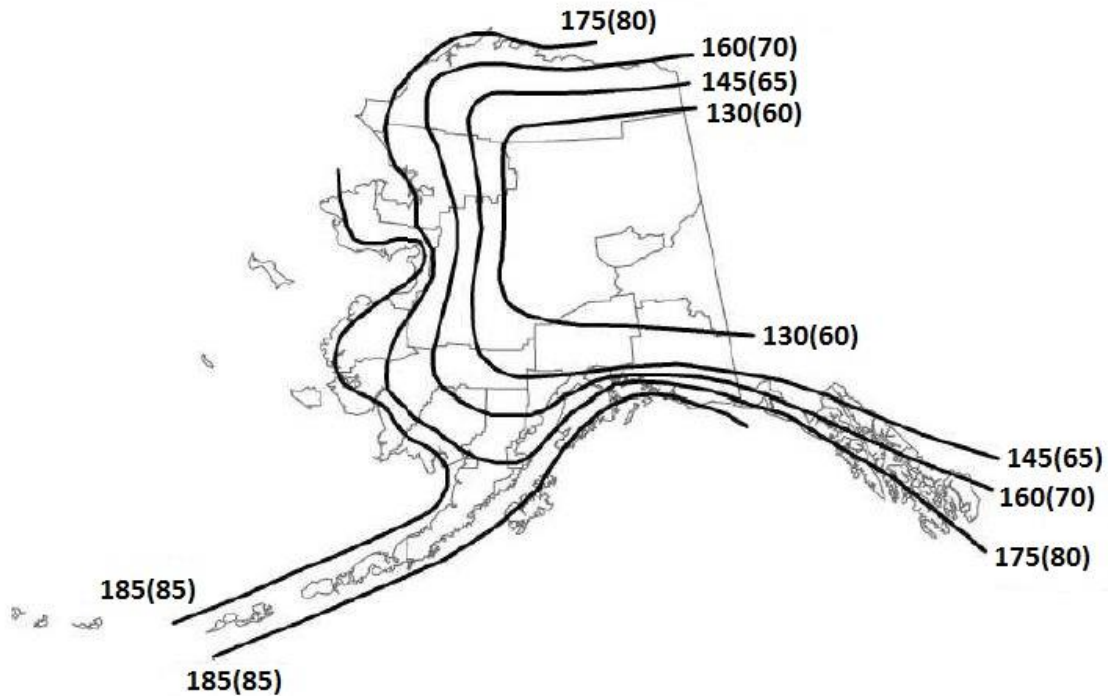

**FIGURE 304.2(2) —continued**

**STORM SHELTER DESIGN WIND SPEEDS, V, FOR HURRICANES - ALASKA**

**304.3 Wind directionality factor.** The directionality factor shall be taken as  $K_d = 1.0$ .

**304.4 Exposure category.** For *tornado shelters*, wind loads shall be based on exposure category C. For *hurricane shelters*, use of exposure category B is not permitted.

**Exception:** For *hurricane shelters*, wind loads for the main wind-force resisting system (MWFRS) only shall be permitted to be based on exposure category B, where exposure category B exists for all wind directions and is likely to remain exposure category B after a hurricane with wind speeds as determined from Section 304.2.

**304.5 Topographic effects.** For *tornado shelters*, the topographic factor  $K_{zt}$  need not exceed 1.0.

(IS-STM 03-10-18 – AM, IS-STM 08-18-18 AS)

**304.6 Enclosure classifications.** Enclosure classifications for *storm shelters* shall be determined in accordance with ASCE 7, Section 6.2. For determining the enclosure classification for *community storm shelters*, the largest door or window impact-protective system on a wall that receives positive external pressure shall be considered as an opening.

(IS-STM 10-04-18 AS, IS-STM 03-28-18 AS, IS-STM 03-11-18 AM)

**304.7 Atmospheric Pressure Change (APC).** For *tornado shelters* classified as enclosed buildings, the additional internal pressures caused by atmospheric pressure change shall be considered. The internal pressure coefficient,  $GC_{pi}$ , shall be taken as  $\pm 0.18$  ~~when~~ where APC venting area of 1 square foot (0.0929 m<sup>2</sup>) per 1,000 cubic feet (28.3 m<sup>3</sup>) of interior storm shelter volume is provided. APC venting shall consist of openings in the storm shelter roof having a pitch ~~not greater than~~ 10 degrees or less from the horizontal or openings divided equally (within 10 percent of one another) on opposite walls. A combination of APC venting meeting the above requirements is permitted.

**Exception:** Calculation of venting area to relieve APC is not required for *tornado shelters* classified as partially enclosed buildings. An internal pressure coefficient of  $GC_{pi} = \pm 0.55$  shall be used for *tornado shelters* where APC venting meeting the requirements of Section 304.7 is not provided, or where APC venting area requirements are not calculated.

(IS-STM 03-28-18 AS)

**304.8 Shielding of *storm shelters* by host and adjacent buildings.** *Storm shelters* enclosed in, partially enclosed in or adjacent to *host buildings* or adjacent to other buildings not designed for the load requirements of Chapter 3 shall be designed considering the *host building* and adjacent buildings to be destroyed and the storm shelter to be fully exposed.

(IS-STM 03-28-18 AS)

**304.9 *Storm shelters* connected to *host buildings*.** Where an element or component of the *host building* is connected to a *storm shelter*, the *storm shelter* shall be designed to resist the maximum force that could be transmitted to the storm shelter equal to the ultimate failure strength of the connection or element being connected, whichever is lower, concurrent with the other wind loads on the *storm shelter* required by Chapter 3.

## SECTION 305 DEBRIS HAZARDS

(IS-STM 03-28-18 AS)

**305.1 Wind-borne debris.** All storm shelters shall be designed for the impact of wind-borne debris in accordance with this section.

(IS-STM 03-28-18 AS)

**305.1.1 Missile criteria for *tornado shelters*.** The debris impact test missile for all components of the storm shelter envelope of *tornado shelters* shall be a 15-pound (6.8 kg) sawn lumber 2 by 4 traveling at the speeds shown in Table 305.1.1.

(IS-STM 03-28-18 AS)

**TABLE 305.1.1  
SPEEDS FOR 15-lb SAWN LUMBER 2 x 4 MISSILE  
FOR TORNADO SHELTERS**

DESIGN WIND SPEED	MISSILE SPEED AND TORNADO SHELTER IMPACT SURFACE
130 mph	80 mph Vertical Surfaces 53 mph Horizontal Surfaces

160 mph	84 mph Vertical Surfaces 56 mph Horizontal Surfaces
200 mph	90 mph Vertical Surfaces 60 mph Horizontal Surfaces
250 mph	100 mph Vertical Surfaces 67 mph Horizontal Surfaces

For SI: 1 mile per hour = 0.447 m/s.

**(IS-STM 03-28-18 AS)**

**305.1.2 Missile criteria for hurricane shelters.** The debris impact test missile for all components of the storm shelter envelope of hurricane shelters shall be a 9-pound (4.1 kg) sawn lumber 2 by 4. The speed of the test missile impacting vertical storm shelter surfaces shall be a minimum of 0.50 times the storm shelter design wind speed. The speed of the test missile impacting horizontal surfaces shall be 0.10 times the storm shelter design wind speed.

**(IS-STM 03-17-19 AM, IS-STM 03-28-18 AS)**

**305.2 Testing for missile impacts.** ~~Testing for missile impact of all components of the shelter envelope.~~ All components of the storm shelter envelope shall be tested for missile impact shall be in accordance with Section 305 following the test procedures of Section ~~803~~ 804.

**Exception:** Floors of the storm shelter envelope are not required to be tested for missile impact.

**(IS-STM 03-17-19 AM, IS-STM 03-28-18 AS)**

**305.2.1 Vertical or horizontal Inclined surfaces.** ~~Walls, doors and other Storm shelter envelope surfaces~~ Storm shelter envelope surfaces inclined 30 degrees (.52 rad) or more from the horizontal shall be considered vertical surfaces. Storm shelter envelope surfaces inclined less than 30 degrees (.52 rad) from the horizontal shall be ~~treated as~~ considered horizontal surfaces.

**(IS-STM 03-28-18 AS, IS-STM 10-07-18 AM)**

**305.2.2 Soil-covered portions of storm shelters.** Portions of soil-covered storm shelters, with less than 12 inches (304.8 mm) of soil cover protecting storm shelter horizontal surfaces, or with less than 36 inches (914.4 mm) of soil cover protecting storm shelter vertical surfaces, shall be tested for resistance to missile perforation as though the surfaces were exposed. To qualify for shielding from soil cover, the soil surfaces shall slope away from the entrance walls or other near-grade enclosure surfaces of underground storm shelters at a slope of not more than 2 inches per foot for a horizontal distance of not less than 3 feet (914 mm) from the exposed portions of the storm shelter or unexposed portions deemed to be protected by soil cover. See Figure 305.2.2 for an example.

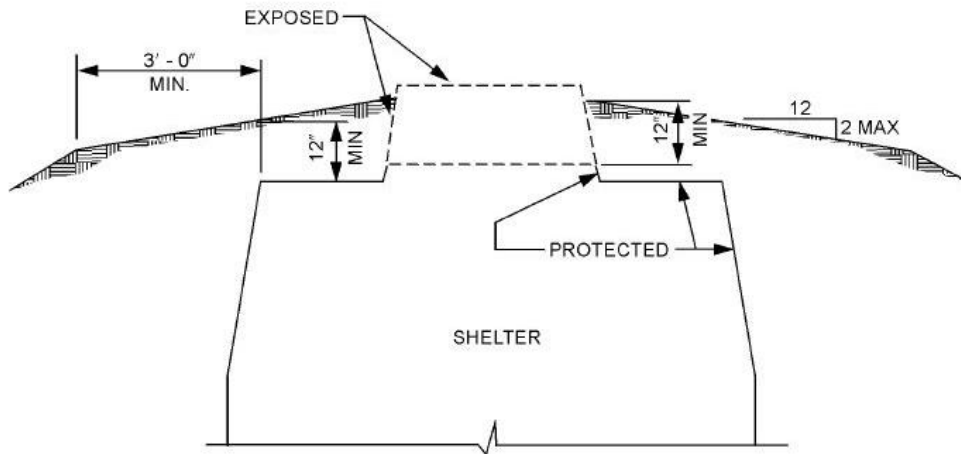

For SI: 1 inch = 25.4 mm, 1 foot = 304.8 mm.

(IS-STM 03-28-18 AS)

FIGURE 305.2.2

**UNDERGROUND STORM SHELTERS**

(IS-STM 03-28-18 AS, IS-STM 03-12-18 AM)

**305.3 Laydown and falling debris hazards.** ~~Lay down, rollover and collapse hazards shall be considered by the design professional when determining the location of shelters on the site. Where the roof of the storm shelter is within the laydown radius of a *laydown hazard* or the fall radius of a *falling debris hazard*, the storm shelter shall be designed to resist the impact loads from such hazards.~~

(IS-STM 03-12-18 AM)

**305.3.1 Laydown radius.** The laydown radius is a horizontal distance equal to the height of the *laydown hazard*.

(IS-STM 03-12-18 AM)

**305.3.2 Fall radius.** The fall radius is a horizontal distance equal to half the difference between the height of the *falling debris hazard* and the height of the roof of the storm shelter but need not exceed 30 ft (9.1 m).

(IS-STM 03-12-18 AM)

**305.3.3 Impact loads.** Impact loads from laydown and falling debris hazards shall be determined using a minimum impact factor of 2.0 times the estimated weight of the debris hazard. Each laydown and falling debris hazard load shall be considered one at a time, applied simultaneously with the uniform live loads on the roof of the shelter in accordance with Section 303.2.

(IS-STM 03-14-18-AM, IS-STM 03-28-18 AS)

SECTION 306

**STORM SHELTER ENVELOPE COMPONENT DESIGN AND TESTING AND DESIGN**

(IS-STM 03-28-18 AS, IS-STM 03-30-18 AS)

**306.1 Storm Shelters meeting tornado impact test requirements.** *Storm shelter envelope* components meeting missile impact test requirements for *tornado shelters* at the same geographic location shall be considered acceptable for *hurricane shelters* provided they meet structural design load requirements for *hurricane shelters*.

(IS-STM 06-04-18 AM)

**306.2 Shelter fire resistance.** Shelter envelope components shall be fire-resistance rated in accordance with Section 603 and the applicable code.

**306.3 ~~306.2~~ Roof and wall assemblies.** Roof and wall assemblies shall meet the missile impact criteria of Section 305.1, and the pressure requirements of Section 304.1.

(IS-STM 03-15-18-AS, IS STM 08-13-18 AM, IS-STM 03-28-18 AS)

**306.4 ~~306.3~~ Wall and roof openings.** All openings in the *storm shelter envelope* shall be protected in accordance with this section Sections 306.4.1 through 306.4.6, as applicable, by doors complying with Section 306.3.1, windows complying with Section 306.3.2, other impact-protective systems complying with Section 306.4 or baffled to prevent wind-borne debris from entering the shelter protected occupant area in accordance with Section 306.5. Any changes to listed *impact-protective systems*, such as a change of glazing, shall require evaluation by the listing agency or retesting of the entire assembly.

(IS-STM 08-18-18 AS, IS-STM 08-19-18 AM)

**306.4.1 ~~306.3.4~~ Testing of *storm shelter door assemblies*.** Door assemblies, including rolling and sectional door assemblies, for use in the *storm shelter envelope* shall be tested in accordance with missile impact and pressure test procedures described in Chapter 8.

(IS-STM 03-15-18-AS, IS-STM 03-17-18 AM, IS-STM 08-18-18 AS, IS-STM 05-14-18 AM/AFM)

**306.4.1.1 ~~306.7~~ Door undercut.** Door or shutter assemblies for use in the *storm shelter envelope* with a threshold at the level of exit discharge shall be limited to a 3/4-inch (19.1 mm) maximum undercut. ~~A weather seal at the door undercut where doors are exposed to weather.~~

**306.4.2 ~~306.3.2~~ Testing of window assemblies and other glazed openings.** Operable and nonoperable windows and other glazed openings including skylights, side lights and transoms, shall be tested for missile impact in accordance with Section ~~803~~ ~~804~~ and cyclic pressure in accordance with Section ~~804~~ ~~805~~.

**Exceptions:**

1. Missile impact testing shall not be required for window assemblies and other glazed openings where the opening is protected by a device conforming to Section ~~306.4~~ ~~306.4.3~~ located on the exterior side of the opening.
2. Missile impact testing and pressure testing shall not be required for window assemblies and other glazed openings where the opening is protected by a device conforming to Section ~~306.4~~ ~~306.4.3~~ located on the interior side of the opening.

**306.4.2.1 ~~306.3.2.1~~ Window and skylight assemblies for tornado shelters.** Window and skylight assemblies for use in *tornado shelters* shall comply with the missile impact requirements of Section 305.1.1 and the pressure requirements of Section 304. Window and skylight assemblies for use in *tornado shelters* shall be tested for missile impact in accordance with Section ~~803~~ ~~804~~ and pressure in accordance with Sections ~~804.3~~ ~~805.3~~ and ~~804.4~~ ~~805.4~~.

**306.4.2.2 ~~306.3.2.2~~ Window and skylight assemblies for hurricane shelters.** Window and skylight assemblies for use in *hurricane shelters* shall comply with the missile impact requirements of Section 305.1.2 and the pressure requirements of Section 304. Window and skylight assemblies for use in *hurricane shelters* shall be tested for missile impact in accordance with Section ~~803~~ ~~804~~ and cyclic pressure in accordance with Section ~~804.4~~ ~~805.4~~.

**(IS-STM 03-15-18-AS)**

**306.4.3 ~~306.4~~ Testing of Impact-protective systems.** *Impact-protective systems* shall be tested for missile impact in accordance with Chapter 8.

**Exception:** Nonoperable, permanently affixed shields or cowlings are excluded from pressure testing requirements of Section ~~806.5.~~ ~~805.5~~.

**(IS-STM 03-16-18 AM, IS-STM 03-28-18 AS)**

**306.4.3.1 ~~306.4.1~~ Impact-protective systems in tornado shelters.** *Impact-protective systems* in *tornado shelters* shall be permanently affixed. All operable *impact-protective systems* shall ~~be manually operable~~ include manual, non-powered operation capabilities from inside the *storm shelter*.

**(IS-STM 03-15-18 AS, IS-STM 10-04-18 AS, IS-STM 08-17-18 AS, IS-STM 08-18-18 AS)**

**306.4.4 ~~306.5~~ Testing of alcove or baffled storm shelter entry systems.** All protective elements of *alcove or baffled storm shelter entry systems* shall be designed to meet the wind load requirements of Section 304 and the debris impact test requirements of Section 305. Where a door assembly is employed as part of the protection in such an entry system, the door assembly shall meet the debris impact test requirements of Section 804.9.7 and the pressure testing requirements of Sections ~~804~~ ~~805~~ and ~~805.5~~ ~~806.6~~. The enclosure classification for *storm shelters* with ~~baffled or alcove or baffled storm shelter entry systems~~ entries shall be determined in accordance with Section 304.6.

**Exception:** ~~When~~ Where the entry system for a *residential storm shelter* is equipped with a door assembly that meets the pressure requirements of Section 304, the enclosure classification shall remain unchanged by the *alcove or baffled storm shelter entry system*.

**(IS-STM 03-02-18- AM, IS-STM 03-15-18-AS, IS-STM 03-17-18-AM, IS-STM 03-28-18 AS, IS-STM 03-11-18 AM)**

**306.4.5 ~~306.6~~ Anchorage of doors, windows and shutters for impact-protective systems.** Where anchorage of door, window or shutter framing *impact-protective systems* to the *storm shelter* structure is required by means other than those provided in the manufacturer's listing or installation instructions in accordance with Section 107, alternate anchorage shall be designed for pull-out and shear to resist the *design wind pressures* on the *storm shelter envelope* as determined in accordance with Section 304. ~~and the anchor placement detailed in accordance with accepted engineering practice. The alternate anchorage details and calculations shall be provided as part of the construction documents.~~

(IS-STM 03-15-18-AS)

~~306.7 Door undercut. (relocated)~~

(IS-STM 03-15-18-AS, IS-STM 03-19-18 AM, IS-STM 03-20-18 AM) (IS-STM 03-28-18 AS)

~~306.4.6~~ ~~306.8~~ **Joints, gaps or voids in *storm shelter envelope*.** Joints, gaps or voids in a *storm shelter envelope* that opens into the *protected occupant area* similar to masonry control joints, expansion joints, opening protective device shim spaces, air louver blades, grates, grilles, screens or precast panel joints shall be considered openings and shall be protected in accordance with Sections ~~306.3 and 306.4~~ 306.4.1, 306.4.2 or 306.4.3.

**Exceptions:**

1. Masonry control joints, masonry or concrete expansion joints ~~or precast concrete panel joints~~  $\frac{3}{8}$ -inch (9.5 mm) or less in width, sealed with joint material in accordance with TMS 602 for masonry or ASTM C920 for concrete.
2. Precast concrete panel joints shall be permitted to be  $\frac{3}{4}$ -inches (19 mm) or less in width where sealed with joint material in accordance ASTM C920.
3. ~~Joints, gaps or voids that will not allow a direct debris path through the *storm shelter envelope* into the *protected occupant area*. Debris particles shall impact at least two surfaces meeting the missile impact criteria of Section 305.1 prior to arriving at the *protected occupant area*. Straight missile paths and elastic impacts are assumed in determining missile trajectories.~~

(IS-STM 03-21-18 AM (relocated and split), IS-STM 03-22-18 AM coordination)

**SECTION 307**

**WEATHER PROTECTION**

(IS-STM 03-21-18 AM, IS-STM 01-02-18 AM)

~~307.1 Exterior cladding of hurricane shelters.~~ All exposed components and cladding assemblies and roof coverings of hurricane shelters shall be designed to resist rainwater penetration during the design windstorm and shall be designed and installed to meet the wind load requirements of Section 304.

**Exception:** Residential shelters that are fully enclosed in a host building constructed in compliance with the local building code.

(IS-STM 03-22-18 AM)

~~307.2 Electrical grounding of shelters.~~ Exposed metal interior surfaces of shelters that are electrically grounded and electrical fixtures within shelters shall be grounded only to the host building external grounding system.

**SECTION 307 308**

**CONNECTION OF STORM SHELTERS TO FOUNDATIONS OR SLABS**

(IS-STM 03-27 AM, IS-STM 03-28-18 AS)

~~307.1~~ ~~308.4~~ **Connections of storm shelters to foundations or slabs systems.** Storm shelters shall be designed to resist all loads specified in Chapter 3 and to transfer the resultant forces into the ground with a type of foundation system.

(IS-STM 10-08-18 AS, IS-STM 03-27 AM, IS-STM 03-28-18 AS, IS-STM 03-11-18 AM)

~~307.1.1~~ ~~308.4.4~~ **Calculation of resistance.** Structural stability of *storm shelters* shall be determined by engineering calculations for design wind loads pressures determined in accordance with Section 304. Where *storm shelters* are anchored to foundation systems ~~foundations or slabs on-grade whose and such~~ top surfaces ~~extending extend~~ outward from the *storm shelter* walls are at grade, the top surfaces of the foundation systems ~~foundations or slabs~~ shall not be considered to have wind uplift forces acting on them.

(IS-STM 03-27 AM, IS-STM 03-28-18 AS)

~~307.1.2~~ ~~308.4.4.3~~ **Elevated *storm shelter* foundations foundation systems.** Where *storm shelters* are constructed with the top of the supporting foundation structure system located at an elevation higher than the

surrounding finished grade level, the structural stability of the *storm shelter* and elevated supporting foundation ~~structure system~~ shall be computed assuming that both are fully exposed to the *storm shelter* design wind and flood forces. Where applicable, and in accordance with ASCE 7, the impacts of wind-borne and flood-borne debris on stability of the foundation system shall be considered.

(IS-STM 03-27 AM)

**308.1.1.1 Slabs-on-grade.** ~~New or existing slabs-on-grade shall be designed for the applicable loads in accordance with Section 301; however, The minimum thickness shall be 3-1/2 inches (88.9 mm) and the minimum steel reinforcement for slabs-on-grade resisting forces on the *storm shelter* shall be 6 x 6 W1.4 x W1.4 welded wire reinforcement over the required area of slab or No. 4 bars, at a maximum spacing of 18 inches (457 mm) on center, in two perpendicular directions.~~

**Exception:** ~~Concrete and concrete masonry *storm shelters* shall be permitted to be constructed within existing one- and two-family dwellings on existing slabs-on-grade without a foundation, under the following conditions:~~

- ~~1. Calculated soil pressure under the slabs-on-grade supporting the *storm shelter* walls shall not exceed 2000 psf (95.8 kN/m<sup>2</sup>) for design loading conditions other than design *storm shelter* events and 3000 psf (143.7 kN/m<sup>2</sup>) for design *storm shelter* events.~~
- ~~2. The *storm shelter* is anchored at a minimum to the slab-on-grade at each corner of the structure and on each side of the doorway opening.~~
- ~~3. Reinforcing in the slab-on-grade shall not be required where the dead load of the slab is not required to resist overturning.~~

(IS-STM 03-27 AM, IS-STM 01-02-18 AM-CC)

**307.2 Slabs-on-ground.** Where slabs-on-ground are serving as part of the foundation system for the storm shelter, the slabs-on-ground shall be designed in accordance with ACI 318 to resist all loads specified in Chapter 3 and to transfer the resultant forces into the ground.

**Exception:** Slabs-on-ground within a storm shelter not utilized to transfer wind forces acting on the storm shelter to the ground or to a foundation system supporting the storm shelter shall be designed in accordance with the applicable building code.

(IS-STM 03-27 AM)

**307.2.1** ~~308.1.1.2~~ **Joints in concrete slabs-on- ground grade.** Design calculations for concrete slabs-on-ground grade supporting *storm shelters* shall include the effect of expansion joints, contraction joints or construction joints where such slabs-on- ground grade are utilized to resist tensile and shear loads from the supported *storm shelters*.

(IS-STM 03-27 AM)

**307.3 Existing slabs-on-ground supporting storm shelters.** Replacement or strengthening of existing slabs-on-ground where a storm shelter is to be installed shall not be required where all of the following conditions apply:

1. Community storm shelters that are a single story in height with a footprint of 64 ft<sup>2</sup> (5.95 m<sup>2</sup>) or less or residential storm shelters.
2. The storm shelter are constructed out of concrete or concrete masonry.
3. Calculated soil pressure under the slabs-on-ground supporting the storm shelter walls does not exceed 2000 psf (95.8 kN/m<sup>2</sup>) for design loading conditions other than design storm shelter events and 3000 psf (143.7 kN/m<sup>2</sup>) for design storm shelter events.
4. The storm shelter is anchored at a minimum to the slab-on-ground at each corner of the structure and on each side of door openings in the shelter envelope.

**SECTION 308 309**  
**PENETRATIONS OF STORM SHELTER ENVELOPE BY SYSTEMS AND UTILITIES**

(IS-STM 03-24-18 AS, IS-ST 03-25-18-AS, IS-STM 01-02-18 AM, IS-STM 03-28-18 AS)

**308.1 ~~309.1~~ Penetrations of storm shelter envelope by mechanical, electrical and plumbing systems.** Penetrations through the *storm shelter envelope* of mechanical, electrical and plumbing systems, including piping and utility lines, larger than 3<sup>1</sup>/<sub>2</sub> square inches (2258 mm<sup>2</sup>) in area for rectangular penetrations or ~~2-1/4~~ 2-1/2 inches (~~52.38~~ 63.5 mm) in diameter for circular penetrations, shall be considered openings and shall be protected in accordance with Section 306.3. Penetrations of the *storm shelter envelope* shall not degrade the structural integrity of the *storm shelter* and missile impact resistance of the *storm shelter envelope*.

Penetrations of the *storm shelter envelope* by hazardous gas or liquid lines shall have automatic shutoffs to protect against leakage due to movement of the utility line. The threshold movements for shutoff shall be as defined by the applicable codes and standards governing such utility lines.



## CHAPTER 4

### SITING

(IS-STM 04-12-18 AS)

#### SECTION 401 GENERAL

(IS-STM 04-12-18 AS)

**401.1 Scope.** The requirements of this chapter shall govern the siting, elevation and travel distance for storm shelters.

(IS-STM 04-09-18 AS)

#### SECTION 402 FLOOD ELEVATION CRITERIA

(IS-STM 04-09-18 AS, IS-STM 04-13-18 AS)

**402.1 General.** Storm shelters sited within flood hazard areas shall consider flood elevations in accordance with this section. Such storm shelters shall be designed and constructed to resist the effects of flood hazards and flood loads in accordance with Section 303.4.

(IS-STM 04-10-18 AS)

**401.1 Minimum floor elevation of storm shelters.** (relocated)

(IS-STM 04-10-18 AS)

**401.1.1 Minimum floor elevation of community shelters.** (relocated and split)

(IS-STM 04-10-18 AS)

**401.1.2 Minimum floor elevation of residential shelters.** (relocated and split).

(IS-STM 04-05-18-AS, IS-STM 04-09-18-AS)

**402.2 401.2 Design criteria.** The design and construction of storm shelters or portions thereof subject to flooding located in flood hazard areas, including coastal high-hazard areas and coastal A zones shall be designed in accordance with the provisions of this chapter, ASCE 7, Section 5 and ASCE 24 except for the floor elevations for storm shelters required in Section 402.7.

(IS-STM 04-09-18-AS)

**402.3 Determining flood elevations and floodway.** The flood elevation and floodway shall be determined using the flood hazard map adopted by the applicable governing authority. Where flood elevations and floodway are not included in the flood hazard map, or where a flood elevation study is not adopted by the applicable governing authority, the flood elevation and floodway shall be determined in accordance with one of the following:

1. Utilize a flood elevation and floodway data available from federal, state or other approved source.
2. Determine the flood elevation and floodway in accordance with the accepted hydrologic and hydraulic engineering practices used to prepare a flood elevation study. Determination shall be undertaken by a registered design professional who shall document that the technical methods used reflect currently accepted engineering practice.

(IS-STM 04-09-18-AS)

**402.4 Flood Information.** Flood information shall be provided on the construction documents in accordance with Section ~~107.2.1~~ 106.2.1.

(IS-STM 04-08-18-AS) (IS-STM 04-13-18-AS)

**402.5 404.1 Community storm shelter siting.** Community storm shelters shall be located outside of the following high-risk flood hazard areas:

1. Flood hazard areas subject to high-velocity wave action (V zones); Coastal high-hazard areas and coastal A zones.

2. Floodways.

**Exception:** *Community storm shelters* shall be permitted in flood hazard areas subject to high-velocity wave action (*V-zones*) *coastal high-hazard areas* and *coastal A zones* where permitted by the Board of Appeals in accordance with the provisions of the *International Building Code*.

(IS-STM 04-08-18-AS, IS-STM 04-13-18-AS)

**402.6 Residential storm shelter siting.** *Residential storm shelters* shall be located outside of the following high-risk flood hazard areas:

1. *Coastal high-hazard areas* and *coastal A zones*.
2. Floodways.

**Exception:** *Residential storm shelters* shall be permitted in *coastal high-hazard areas* and *coastal A zones* where permitted by the Board of Appeals in accordance with the provisions of the *International Building Code* or *International Residential Code*.

(IS-STM 04-10-18 AS)

**402.7 401.4 Minimum floor elevation of storm shelters.** Where *storm shelters* are sited within *flood hazard areas*, the minimum floor elevations of *storm shelters* shall be determined in accordance with Section 401.1.1 or 401.1.2 402.7.1, 402.7.2, 402.7.3, 402.7.4, as applicable.

(IS-STM 04-10-18 AS, IS-STM 04-13-18-AS)

**402.7.1 401.4.4 Minimum floor elevation of community tornado shelters.** The lowest floor used for the *occupied storm shelter areas* and *occupant support areas* of a *community tornado shelter* shall be elevated to or above the higher of the elevations determined by all of the following:

- 1.4. The minimum elevation of the lowest floor required by the *authority having jurisdiction* for the location where the *community tornado shelter* is installed; or
- 2.5. Two feet (610 mm) One foot (305 mm) above the flood elevation having a 1 percent annual chance of being equaled or exceeded in any given year.
- 3.4. For *storm shelters* that are Risk Category IV facilities or serving Risk Category IV facilities in accordance with Table 1604.5 of the *International Building Code*, the flood elevation, including coastal wave effects, having an 0.2-percent annual chance of being equaled or exceeded in any given year; or
4. For *storm shelters* that are Risk Category IV facilities or serving Risk Category IV facilities in accordance with Table 1604.5 of the *International Building Code*, two feet (610 mm) above the flood elevation having a 1 percent annual chance of being equaled or exceeded in any given year.
2. The flood elevation corresponding to the highest recorded flood elevation if a flood hazard study has not been conducted for the area; or
3. The maximum flood elevation associated with any modeled hurricane category, including coastal wave effects; or

**Exception:** Items 1 and 3 shall not apply to shelters designed, constructed, designated and used only as tornado shelters.

Where a *community tornado shelter* is located within a building that is constructed for dry floodproofing in accordance with ASCE 24 to the elevation prescribed by this section, the lowest floor level of the *community tornado shelter* is not required to comply with this section.

(IS-STM 04-10-18 AS, IS-STM 10-05-18 AM, IS-STM 04-13-18-AS)

**402.7.2 401.4.4 Minimum floor elevation of community hurricane shelters.** The lowest floor used for the *occupied storm shelter areas* and *occupant support areas* of a *community hurricane shelter* shall be elevated to or above the higher of the elevations determined by all of the following:

- 1.4. The minimum elevation of the lowest floor required by the *authority having jurisdiction* for the location where the *community hurricane shelter* is installed; or
- 2.5. Two feet (610 mm) above the flood elevation, including coastal wave effects, having a 1 percent annual chance of being equaled or exceeded in any given year.
- 3.4. The flood elevation, including coastal wave effects, having an 0.2-percent annual chance of being equaled or exceeded in any given year; or
2. The flood elevation corresponding to the highest recorded flood elevation if where a flood hazard study has not been conducted for the area; or

~~4.3. The elevation corresponding to the maximum storm surge inundation, flood elevation associated with any modeled hurricane category, including coastal wave effects, associated with the maximum intensity hurricane modeled using the National Hurricane Center's *Sea, Lake and Overland Surges from Hurricanes* (SLOSH) for the location where the *community hurricane shelter* is installed.; or~~

~~**Exception:** Items 1 and 3 shall not apply to shelters designed, constructed, designated and used only as tornado shelters.~~

(IS-STM 04-10-18 AS, IS-STM 10-05-18 AM, **IS-STM 04-13-18-AS**)

~~**402.7.3 401.1.2 Minimum floor elevation of residential *tornado* shelters.** The lowest floor used for the occupied shelter area of a *residential tornado shelter* shall be elevated to or above the higher of the elevations determined by all of the following:~~

- ~~1. The flood elevation, including coastal wave effects, having an 0.2-percent annual chance of being equaled or exceeded in any given year; or~~
- ~~2. The flood elevation corresponding to the highest recorded flood elevation if where a flood hazard study has not been conducted for the area; or~~
- ~~3. The maximum flood elevation associated with any modeled hurricane category, including coastal wave effects; or~~
- ~~1.4. The minimum elevation of the lowest floor required by the *authority having jurisdiction* for the location where the *residential tornado shelter* is installed.~~
- ~~2. In new buildings, one foot (305 mm) above the flood elevation having a 1 percent annual chance of being equaled or exceeded in any given year.~~

~~**Exception:** Items 1 and 3 shall not apply to shelters designed, constructed, designated and used only as tornado shelters.~~

(IS-STM 04-10-18 AS) (**IS-STM 04-13-18-AS**)

~~**402.7.4 401.1.2 Minimum floor elevation of residential *hurricane* shelters.** The lowest floor used for the occupied shelter area of a *residential hurricane shelter* shall be elevated to or above the higher of the elevations determined by all of the following:~~

- ~~1.4. The minimum elevation of the lowest floor required by the *authority having jurisdiction* for the location where the *residential hurricane shelter* is installed.~~
- ~~2.1. The flood elevation, including coastal wave effects, having an 0.2-percent annual chance of being equaled or exceeded in any given year; or~~
- ~~2. The flood elevation corresponding to the highest recorded flood elevation if a flood hazard study has not been conducted for the area; or~~
- ~~3. The elevation corresponding to the maximum storm surge inundation, flood elevation associated with any modeled hurricane category, including coastal wave effects, associated with the maximum intensity hurricane modeled using the National Hurricane Center's *Sea, Lake and Overland Surges from Hurricanes* (SLOSH) for the location where the *residential hurricane shelter* is installed.; or~~

~~**Exception:** Items 1 and 3 shall not apply to shelters designed, constructed, designated and used only as tornado shelters.~~

(IS-STM 04-14-18 AS)

## **SECTION 402 HAZARDOUS MATERIALS**

(IS-STM 04-14-18 AS)

~~**402.1 Proximity to hazardous materials.** Occupants of *community shelters* that are located within a precautionary zone that includes facilities that manufacture, use or store hazardous materials shall be provided with protection from hazardous materials releases as deemed necessary by the *local emergency planning committee* and the *authority having jurisdiction*.~~

(IS-SM 04-11-18-AS, IS-SM 04-12-18-AS)

## **SECTION 403 SITING PROXIMITY MAXIMUM TRAVEL DISTANCE FOR *RESIDENTIAL TORNADO SHELTERS***

**(IS-SM 04-12-18-AS)**

**403.1 Community tornado shelters in schools.** Where required by the *International Building Code*, *community tornado shelters* that serve educational occupancies shall comply with the maximum travel distance to the tornado shelter entrance.

**(IS-SM 04-11-18-AS, IS-SM 04-12-18-AS)**

**403.2 403.1 Residential shelter siting Maximum travel distance for Residential tornado shelters.** *Residential tornado shelters* shall be located within the residence that shelter is intended to serve, or shall be located on the site such that the maximum travel distance of at least one travel path from an access opening on the shelter to an exterior door of any residences that the shelter is intended to serve does not exceed 150 feet (45 720 mm).

**(IS-STM 04-08-18 AS)**

**SECTION 404  
SITING FOR COMMUNITY SHELTERS**

**(IS-STM 04-08-18 AS)**

**~~404.1 Community shelter siting.~~** (relocated)

(IS-STM 05-19-18 AS)

**CHAPTER 5**  
**OCCUPANCY, OCCUPANT DENSITY, MEANS OF EGRESS,**  
**ACCESS, AND ACCESSIBILITY, EMERGENCY EGRESS AND**  
**SIGNAGE**

(IS-STM 05-19-18 AS)

**SECTION 501**  
**GENERAL**

(IS-STM 05-19-18 AS)

**501.1 Scope.** The requirements of this chapter shall govern the occupant density, access, accessibility, emergency egress, and signage for storm shelters.

(IS-STM 05-17-18 AM, IS-STM 05-19-18 AS)

**SECTION 501.502**  
**OCCUPANCY DENSITY IN COMMUNITY STORM SHELTERS**

(IS-STM 05-17-18 AM) (IS-STM 05-19-18 AS)

**501.1 501.4 General.** A community storm shelter shall comply with the requirements of this section of Section 502.2 through 502.4. A residential shelter shall comply with the requirements of Section 502.

(IS-STM 05-17-18 AM, IS-STM 05-19-18 AS)

**502.2 501.4.1 Occupant density.** The minimum required community storm shelter floor area per occupant shall be determined in accordance with Table 501.4.1 502.2, and this section Sections 502.3. The number and type of occupants served by the storm shelter standing, seated, wheelchair or bedridden spaces shall be determined based upon the needs of the storm shelter as determined by the applicable authority having jurisdiction and the designer.

**501.4.3 Wheelchair spaces.** Each storm shelter shall be sized to accommodate a minimum of one wheelchair space for every 200 storm shelter occupants or portion thereof.

(IS-STM 05-17-18 AM, IS-STM 05-19-18 AS)

**Table 502.2 501.4.1**  
**OCCUPANT DENSITY – COMMUNITY STORM SHELTERS**

<u>TYPE OF SHELTER</u> - <u>TYPE OF OCCUPANTS</u>	MINIMUM REQUIRED <i>USABLE STORM SHELTER FLOOR AREA</i> <sup>a</sup> -IN SQUARE FEET PER OCCUPANT
Tornado	
<u>Occupants who are Standing or seated</u>	5
<u>Occupants using a Wheelchair</u>	10
<u>Occupants who are relocated in a bed or stretcher</u> <u>Bedridden</u>	30
Hurricane	

Occupants who are Standing or seated	20
Occupants using a Wheelchair	20
Occupants who are relocated in a bed or stretcher Bedridden	40

For SI: 1 square foot = 0.0929 m<sup>2</sup>.

a. See Section 501.1.2 for requirements for minimum required usable shelter floor area.

(IS-STM 05-01-18 AM, IS-STM 05-19-18 AS)

**502.3 501.4.2 Usable storm shelter floor area.** The *usable storm shelter floor area* shall be determined by Section 501.4.2.1 or 501.4.2.2 502.3.1, 502.3.2 or a combination of these methods.

(IS-STM 05-17-18 AM, IS-STM 05-19-18 AS)

**502.3.1 501.4.2.1 Calculation of usable storm shelter floor area.** The *usable storm shelter floor area* shall be determined by using the following percentages:

1. Reducing the gross floor area of *storm shelter* areas with *areas of concentrated furnishings* or fixed seating by a minimum of 50 percent.
2. Reducing the gross floor area of *storm shelter* areas with *areas of unconcentrated furnishings* and without fixed seating by a minimum of 35 percent.
3. Reducing the gross floor area of *storm shelter* areas with *areas of open plan furnishings* and without fixed seating by a minimum of 15 percent.

(IS-STM 05-17-18 AM, IS-STM 05-19-18 AS)

**502.3.2 501.4.2.2 Alternative calculation of usable floor area.** The *usable storm shelter floor area* shall be determined by subtracting from the gross floor area, the floor area partitions and walls, columns, fixed or movable objects, furniture, equipment or other features that under probable conditions cannot be removed.

(IS-STM 05-03-18 AM, IS-STM 05-17-18 AM, IS-STM 05-19-18 AS)

**502.4 Tornado Shelter Usable floor area.** In *community tornado shelters* the following *occupant support areas* shall be permitted to be considered *usable storm shelter floor area*:

1. Where the entire storm shelter is a single occupant toilet room area.
2. Where the storm shelter includes multi-stall toilet rooms, the toilet room area other than the toilet stalls and temporary toilet stations privacy areas provided to meet the requirements for toilet stations in Section 702.2. The usable storm shelter floor area shall be calculated by Section 502.3.1, 502.3.2, or a combination of these methods.

(IS-STM 05-17-18 AM, IS-STM 05-19-18 AS)

## **SECTION 503 502 OCCUPANT DENSITY IN RESIDENTIAL STORM SHELTERS**

(IS-STM 05-17-18 AM, IS-STM 05-19-18 AS)

**503.1 502.4 General.** A *residential storm shelter* shall comply with the requirements of this section of Section 503.1 through 503.3. A *community shelter* shall comply with the requirements of Section 501.

(IS-STM 05-17-18 AM, IS-STM 05-19-18 AS)

**503.2 502.4 Occupant density.** The minimum required *usable storm shelter floor area* per occupant for *residential storm shelters* shall be determined in accordance with Table 502.4 **503.2** and **Section** 503.3.

(IS-STM 05-17-18 AM, IS-STM 05-19-18 AS)

## **TABLE 503.2 502.4 OCCUPANT DENSITY—RESIDENTIAL STORM SHELTERS**

<u>TYPE OF SHELTER-TYPE OF OCCUPANTS</u>	<u>MINIMUM REQUIRED <i>USABLE STORM SHELTER FLOOR AREA</i> IN SQUARE FEET PER OCCUPANT</u>
Tornado	
One- and two-family dwelling	3
Other residential	5
Hurricane	
One- and two-family dwelling	7
Other residential	10

For SI: 1 square foot = 0.0929 m<sup>2</sup>.

(IS-STM 10-05-18 AM, **IS-STM 05-19-18 AS**)

**503.3 502.4.1 Usable ~~tornado~~ storm shelter floor area.** The *usable ~~tornado~~ storm shelter floor area* shall be the gross floor area, minus the area of sanitary facilities, if any, and shall include the protected occupant area between the shelter walls at the level of fixed seating, ~~where fixed seating exists~~ determined by subtracting from the gross floor area, the floor area partitions and walls, columns, fixed or movable objects, furniture, equipment or other features that under probable conditions cannot be removed.

(IS-STM 05-19-18 AS)

#### **SECTION 504**

#### **ACCESS AND EMERGENCY EGRESS IN COMMUNITY SHELTERS**

(IS-STM 05-19-18 AS)

**504.1 General.** A community storm shelter shall comply with the access and egress requirements of Section 504.2 through 504.6.

IS-STM 05-17-18 AM, IS-STM 05-19-18 AS)

**504.2 501.6 Accessibility Accessible route.** Buildings and space used as community storm shelters shall be accessible in accordance with the applicable code. ~~Shelters shall be provided with an accessible route in accordance with ICC A117.1.~~

(IS-STM 05-19-18 AS)

**504.3 Wall and roof openings.** All access openings, means of egress doors, emergency escape openings and overhead hatches in the *storm shelter envelope* shall comply with the design and testing requirements in Section ~~306.3-306.4~~

(IS-STM 01-02-18 AM; IS-STM 05-05-18 AM, **IS-STM 05-17-18 AM, IS-STM 05-18-18 AM, IS-STM 05-19-18 AS, IS-STM 06-04-18 AM**)

**504.4 501.2 Number of Doors.** The number of means of egress doors from a space shall be determined based upon the occupant load for the normal occupancy of the space in accordance with the *applicable building code*. ~~For facilities used solely for shelters, the number of doors shall be determined in accordance with the applicable building code based upon the occupant load as calculated in Section 501.1. The number of doors shall also comply with Section 603.~~

Where the *applicable building code* requires only one means of egress door from the storm shelter, the storm shelter shall also provide for emergency egress by an emergency escape opening ~~shall be provided~~ in accordance with Section ~~504.4 504.5~~ or an overhead hatch accessed by an emergency stair, ladder or alternating tread device in accordance with Section 506.

**Exception:** Storm shelters having an occupant load ~~storm shelter design occupant capacity~~ not exceeding 16 are not required to have an emergency escape opening.

(IS-STM 05-06-18 AM, IS-STM 01-02-18 AM, **IS-STM 05-19-18 AS**)

**504.4.1 ~~504.3~~ Direction of swing.** The direction of the swing of doors shall be as required by the applicable building code for the normal occupancy of the space and in accordance with the manufacturer's listing.

(IS-STM 05-19-18 AS)

**504.4.2 ~~504.5~~ Door operation.** Means of egress doors shall be operable from the inside without the use of keys or special knowledge or effort.

(IS-STM 05-19-18 AS)

**504.5 ~~504.4~~ Emergency escape opening.** The emergency escape opening shall be an additional door or an opening that ~~is~~ complies with the following:

1. Have a minimum net clear opening of 5.7 square feet (0.530 m<sup>2</sup>) ~~in area.~~
2. ~~Such opening shall~~ Have a minimum net clear opening height of 24 inches (610 mm) and a minimum net clear opening width of 20 inches (508 mm).
3. ~~The emergency escape opening~~ Shall be operable from the inside without the use of tools or special knowledge.
4. Where the bottom of the clear ~~emergency escape~~ opening is located more than 44 inches (1117.6 mm) above the finished floor level, vertical access to the opening shall be provided by a an emergency stair complying with Section 502.3.4 506.2 or a ladder complying with Section 502.3.2 506.3, or an alternating tread device complying with Section 502.3.3 506.4.

~~The emergency escape opening shall be located away from the means of egress door by a minimum distance of one-third of the length of the maximum overall diagonal dimension of the area to be served.~~

**Exception:** The minimum net clear opening shall be permitted to be 5 square feet where the bottom of the emergency escape opening is not more than 44 inches (1118 mm) above or below finished grade.

(**IS-STM 10-04-18 AS**, IS-STM 05-17-18 AM, IS-STM 05-19-18 AS)

**501.4.1 ~~Ladders for community shelters.~~** ~~Ladders for *community shelter*, which are required for access to emergency escape openings above the level of normal egress, shall comply with the requirements of Section 502.3.2. When the access opening is located on a vertical surface (see Section 305.2.1), the height of the opening shall be not less than 30 inches (762 mm).~~

(**IS-STM 05-05-18 AM**, IS-STM 05-19-18 AS)

**504.6 Multi-story shelter.** Storm shelters with multiple stories shall be required to have one emergency means of vertical access provided within the storm shelter to a level of exit discharge provided by a emergency stair complying with Section 506.2 or a ladder complying with Section 506.3, or an alternating tread device complying with Section 506.4.

(IS-STM 05-19-18 AS)

## **SECTION 505**

### **ACCESS AND EMERGENCY EGRESS IN RESIDENTIAL STORM SHELTERS**

(IS-STM 05-19-18 AS)

**505.1 General.** A residential storm shelter shall comply with the access and egress requirements of Section 505.2 through 505.4.

(IS-STM 05-19-18 AS)

**505.2 Wall and roof openings.** All access openings, means of egress doors and overhead hatches in the *storm shelter envelope* shall comply with Section 306.4.

(IS-STM 05-19-18 AS)



**505.3 Entry and egress.** The residential storm shelter shall be provided with a method of entry and egress by a means of egress door, an access opening complying with Section 505.3.2 or an overhead hatch complying with Section 506.5.

(IS-STM 05-19-18 AS)

**505.3.1 502.5 Door operation.** Means of egress doors shall be operable from the inside without the use of keys or special knowledge or effort.

(IS-STM 05-19-18 AS, IS-STM 05-17-18 AM)

**502.2 505.3.2 Access openings.** ~~All residential shelters~~ Access openings shall be provided with a method of entry and egress with ~~minimum~~ a clear opening dimensions of 24 inches by 30 inches (610 mm by 762 mm) ~~minimum~~.

(IS-STM 05-19-18 AS, IS-STM 05-17-18 AM)

**505.4 502.3 Vertical access.** Where ~~required~~ provided, vertical access to a residential storm shelter shall be by an emergency stair complying with Section ~~502.3.1~~ 506.2, or by a ladder complying with Section ~~502.3.2~~ 506.3, or an alternating tread device complying with Section ~~502.3.3~~ 506.4.

(IS-STM 05-19-18 AS)

## **SECTION 506** **VERTICAL ACCESS**

(IS-STM 05-19-18 AS)

**506.1 General.** Where stairways are required for means of egress for normal use of the space, they shall comply with the applicable code. An emergency stair shall comply with Section 506.2. A ladder shall comply with Section 506.3. An alternating tread device shall comply with Section 506.4. Overhead hatches shall comply with Section 506.5.

(IS-STM 05-17-18 AM, IS-STM 05-19-18 AS)

**506.2 502.3.1 Emergency stairs for residential shelters.** Emergency stairs shall comply with all of the following:

1. Treads shall have a minimum depth of 8 inches (203 mm).
2. Treads shall not be required to have a nosing.
3. Surfaces or treads shall be slip resistant.
4. The maximum height of risers shall be 9<sup>9</sup>/<sub>16</sub> inches (243 mm).
5. The minimum width of the emergency stairs shall be 22 inches (559 mm).
6. The angle of the emergency stair from horizontal shall be a maximum of 50 degrees (0.87 rad).

~~Treads for emergency stairs in residential shelters shall have a minimum depth of 8 inches (203 mm). The maximum height of risers shall be 9<sup>9</sup>/<sub>16</sub> inches (243 mm). Surfaces of steps shall be slip resistant. The minimum width of stairs shall be 22 inches (559 mm). The angle of the stairway from horizontal shall be a maximum of 50 degrees (0.87 rad). Stairs shall be constructed such that a foot is prevented from sliding off either side of the stairway. Stair Treads shall not be required to have a nosing.~~

**Exception:** ~~The maximum height of risers~~ For residential storm shelters, which have a maximum rise between the storm shelter floor level and storm shelter entrance level of 70 inches (1778 mm) maximum, the maximum height of risers shall be 10 inches (254 mm) ~~for 8-inch (203 mm) stair treads.~~

(IS-STM 05-17-18 AM, IS-STM 05-19-18 AS)

**506.2.1 502.3.1.4 Overhead clearance Headroom.** The minimum headroom clearance above any stair tread to an overhead obstruction shall be 6 feet 8 80 inches (2032 mm), measured vertically above the leading edge of the tread from a line connecting the edge of the nosing.

**Exceptions:**

1. The minimum ~~overhead~~ headroom clearance is permitted to be reduced to ~~5 feet~~ 60 inches (1524 mm) where signage is provided at the top and bottom of the emergency stair conspicuously warning the user of low headroom.
2. Entrances that are entered by persons seated on the entrance threshold and that are not high enough for a person to enter standing erect shall not be required to provide minimum headroom clearance provided that there is no more than two ~~stair~~ risers leading into the storm shelter.

(IS-STM 05-19-18 AS)

**506.2.2** ~~502.3.1.2~~ **Stair Handrails.** A continuous handrail shall be located on one side of a ~~stairway~~ emergency stair having more than three risers. Handrail extensions are not required.

(IS-STM 05-08-18 AS, IS-STM 05-17-18 AM, IS-STM 05-19-18 AS)

**506.3** ~~502.3.2~~ **Ladders for residential shelters.** Ladders shall comply with the all of following:

1. The clear width between rails shall be not less than 16 inches (406 mm).
2. Rungs shall be a minimum of 3/4 inch (19 mm) in diameter.
3. Rungs or treads shall be capable of withstanding a 300 pound (136 kg) load.
4. Rungs or treads shall be spaced uniformly at not greater than 12 inches (305 mm).
5. The minimum clearance between the centerline of the rungs or treads to the nearest permanent object in back of the ladder on the toe side shall be no less than 7 inches (178 mm).
6. Ladders shall have a maximum slope of 90 degrees (1.57 rad) from horizontal and a minimum slope of 75 degrees (1.31 rad) from horizontal where measured on the toe side of the ladder.

~~The clear length of rungs for ladders shall be not less than 16 inches (406 mm). Rungs shall be constructed such that a foot cannot slide off the end of the rung. Ladder rungs shall be a minimum of 3/4 inch (19 mm) in diameter and shall be spaced uniformly at not greater than 12 inches (305 mm).~~

~~Ladder wells or cages shall have a minimum of 15 inches (381 mm) clear on either side of the centerline of the ladder and a minimum of 27 inches (686 mm) clear from the centerline of the rungs to a ladder well or cage on the climbing side of the ladder. Where obstructions occur in the ladder well, this distance shall be increased to 30 inches (762 mm).~~

~~The distance between the centerline of the rungs or steps to the nearest permanent object in back of the ladder (on the toe side) shall be no less than 7 inches (178 mm). Ladders shall have a maximum slope of 90 degrees (1.57 rad) from horizontal and a minimum slope of 75 degrees (1.31 rad) from horizontal where measured on the toe side of the ladder.~~

**Exception:** ~~No~~ A minimum clearance is not required on the back side of the ladder where there is no obstruction on the climbing side of the ladder, and where ladder ~~steps~~ treads of 11 inches (279 mm) or greater in width depth are molded or fabricated in a continuous series of treads and risers ~~in which the foot can neither slip through the riser nor be trapped by the riser or next higher ladder stair tread.~~ The maximum slope shall be 90 degrees (1.57 rad) from horizontal and the minimum slope shall be 75 degrees (1.31 rad) from horizontal. See as detailed in Figure 502.3.2 505.3.

(IS-STM 05-08-18 AS, IS-STM 05-17-18 AM, IS-STM 05-19-18 AS)

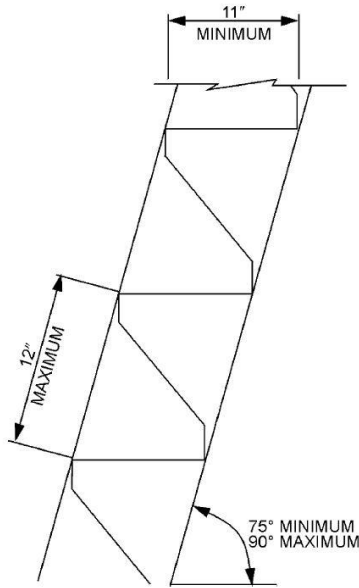

For SI: 1 inch = 25.4 mm, 1 degree = 0.0174 rad.

**FIGURE 502.3.2-505.3**

**Alternative for a ladder in a storm shelter**

(IS-STM 05-19-18 AS)

**506.3.1 502.3.2.1 Ladder Cages or wells.** Ladder cages or ladder wells, shall be where provided for vertical climbs extending more than 8 feet (2438 mm), shall have a minimum of 15 inches (381 mm) clear on either side of the centerline of the ladder and a minimum of 27 inches (686 mm) clear from the centerline of the rungs to a ladder well or obstruction on the climbing side of the ladder.

(IS-STM 05-17-18 AM, IS-STM 05-19-18 AS)

**506.4 502.3.3 Alternating tread devices for residential shelters.** Alternating tread devices for residential shelters shall comply with the applicable requirements listed in the *International Building Code* applicable code.

(IS-STM 05-19-18 AS)

**502.3.3.1 Overhead clearance.** The minimum clearance requirements for stairs (including exceptions) listed in Section 502.3.1.1 shall also apply to alternating tread devices.

(IS-STM 05-19-18 AS)

**506.5 502.3.2.2 Overhead hatches.** Where provided, hatches at the tops of emergency stairs, ladders or alternating tread devices shall have comply with the following:

1. A minimum clear dimensions of 24 inches by 30 inches (610 mm by 762 mm).
2. A clear opening of 24 inches (610 mm) minimum from the centerline the face of the top tread or rung of the emergency stairs, ladders or alternating tread devices on the climbing side of the ladder and
3. A minimum of 15 inches (372 mm) on either side of the centerline of the top tread or rungs shall be provided.
4. Where the access opening is located on a vertical surface in accordance with Section 305.2, the height of the opening shall be 30 inches (762 mm) minimum.
5. Hatches shall open a minimum of 60 degrees (1.04 rad) from the closed position.
6. Hatches shall be counterweighted or otherwise held in the open position when opened.

(IS-STM 05-19-18 AS)

## **SECTION 507 503 LOCKS AND LATCHING**

(IS-STM 05-19-18 AS)

**507.1 503.1 Latching mechanisms.** Latching mechanisms for impact-protective systems shall be permanently mounted on the assembly. Such mechanisms shall require no tools to be engaged in the latched position. Devices such as pins shall be permanently secured to the assembly through the use of chains or wires that must be of corrosion-resistant material.

(IS-STM 05-17-18 AM, IS-STM 05-19-18 AS)

**503.3 Door latches.** Door Latching hardware mechanism necessary for the impact-protective systems door assembly to perform as designed for the *storm shelter* shall ~~either comply with either of the following:~~

1. Automatically engage ~~when~~ where the door impact protective system is in a closed position and shall not be capable of being disabled, ~~or.~~
2. Be capable of being engaged by an occupant. Signage shall be provided with instructions for latching the ~~door~~ impact-protective systems for emergency storm shelter use.

(IS-STM 05-19-18 AS)

**507.2 503.2 Multi-latching systems.** Multi-latching systems for impact-protective systems that are not categorized as a means of egress/escape and are provided with more than one single-action latching mechanism shall be provided with permanently posted instructions on the latching.

(IS-STM 05-09-18 AM, IS-STM 05-19-18 AS)

## **SECTION 508 504 SIGNAGE FOR COMMUNITY SHELTERS**

(IS-STM 05-09-18 AM, IS-STM 05-19-18 AS)

**508.1 504.1 Signage requirements.** *Community storm shelter* areas shall be marked by signage in accordance with this section Sections 508.1.1 through 508.1.5. All storm shelters shall be marked with design information in accordance with Section 508.2. Signage is required within a facility to direct occupants to storm shelter areas. The signs shall comply with the visual character requirements of ICC A117.1.

(IS-STM 05-09-18 AM, IS-STM 05-17-18 AM)

**508.1.1 504.1.1 Shelter entry sign Signage location.** ~~At every entrance to a storm shelter, signage~~ Signage indicating "Tornado Shelter," or "Hurricane Shelter," ~~or~~ and appropriate symbols as applicable, shall be installed outside the storm shelter, adjacent to every door or alcove or baffled storm shelter entry system intended to provide entry into the storm shelter. ~~The signs shall comply with the applicable requirements of ICC A117.1.~~

(IS-STM 05-09-18 AM, IS-STM 05-17-18 AM)

**508.1.2 504.1.2 Storm shelter perimeter sign.** Signage indicating "Notice: Now leaving the Tornado Shelter," or "Notice: Now leaving the Hurricane Shelter," shall be installed inside of the storm shelter, adjacent to every door or alcove or baffled storm shelter entry system which access non-protected areas located outside of the storm shelter.

(IS-STM 05-09-18 AM, IS-STM 05-17-18 AM)

**508.1.3 504.1.3 Storm shelter directional signs.** Signage is required within a facility to direct occupants to storm shelter areas.

(IS-STM 05-09-18 AM, IS-STM 10-06-18 AM)

**504.1.2 Identifying sign.** A sign depicting the general location of storm shelter area(s) and accessways shall be displayed in all of the following locations:

1. Adjacent to access doors on the inside of the storm shelter;
2. In the office of the facility manager, where provided; and
3. In the designated shelter manager's area within the storm shelter, where provided.

(IS-STM 05-09-18 AM)

**504.1.2.1 Location of identifying sign.** The identifying sign shall be posted in a prominent location 60 inches (1524 mm) above the finished floor to the centerline of the sign.

(IS-STM 05-15-19 AM, IS-STM 05-17-18 AM)

**508.1.4 504.1.3 Storm shelter directional signage within a host building.** Where a storm shelter is within a host building, directional signage is required within the host building to direct intended occupants to the storm shelter. The path of travel to the storm shelter shall be clearly marked to indicate the direction of travel in cases where the path of travel is not immediately visible to the intended occupants.

(IS-STM 05-15-19 AM, IS-STM 05-17-18 AM)

**504.1.4 508.1.5 Storm shelter directional signage for a multi building site.** Where a storm shelter serves multiple buildings, directional signage is required to direct intended occupants to the storm shelter.

(IS-STM 05-09-18 AM, IS-STM 01-22-18 AM) – relocated from 108.1 (IS-STM 05-17-18 AM)

**508.2 504.2 Design information.** All storm shelters shall have a sign on or within the storm shelter with all of the following:

1. The storm shelter occupant load.
2. The storm type.
3. The storm shelter design wind speed.
4. The edition of the ICC 500 used for the design.
5. The name of the manufacturer or builder of the storm shelter.

## CHAPTER 6 FIRE SAFETY

(IS-STM 06-07-18 AS)

### SECTION 601 GENERAL

(IS-STM 06-07-18 AS)

**601.1 Scope.** The requirements of this chapter shall govern the fire safety of *community storm shelters*.

(IS-STM 07-01-18 AM)

### SECTION 602 FIRE PROTECTION SYSTEMS

**602.1 Fire protection system.** Fire protection systems shall be provided within the storm shelter where required by the applicable code for the normal use of the space. These systems are not required to be functional or to be protected when the space is occupied as a storm shelter (24 hours for hurricane shelters, 2 hours for tornado shelters) from the wind pressure and missile impact requirements of Chapter 3 or the flood-resistance requirements of Chapter 4.

(IS-STM 06-04-18 AM)

### SECTION 604 603 FIRE-RESISTANT CONSTRUCTION

(IS-STM 06-04-18 AM, IS-STM 01-02-18 AM)

**601.1 Fire separation.** ~~*Fire barriers* and horizontal assemblies separating spaces or areas designated as *storm shelters* from other building areas shall have a minimum fire-resistance rating of 2 hours and shall be constructed in accordance with the applicable building code.~~

**Exception:** ~~Fire separation assemblies are not required for *residential shelters*.~~

(IS-STM 06-04-18 AM, IS-STM 01-02-18 AM-CC, IS-STM 05-18-18 AM-CC, IS-STM 10-09-18 AS)

**603.1 Fire separation.** Walls or horizontal assemblies between *community storm shelters* and other host building areas shall be *fire barriers* or *horizontal assemblies* with a minimum fire-resistance rating of 2 hours constructed in accordance with the applicable building code.

**Exceptions:** Fire barriers and horizontal assemblies are not required for storm shelters with any of the following configurations:

1. The design occupant capacity of 16 or fewer.
2. The storm shelter is located in the basement or underground, the *storm shelter design occupant capacity* is less than 50, two doors are provided and the doors are separated by a minimum horizontal distance equal to 1/3 of the overall diagonal dimension of the storm shelter.
3. The *storm shelter design occupant capacity* is less than 50 and the additional egress door, overhead hatch or emergency escape opening opens directly to the exterior of the building.
4. The means of egress is designed in accordance with the applicable building code for the *storm shelter design occupant capacity* ~~for the storm shelter~~, the storm shelter has at least two means of egress doors and at least at 50 percent of the total required capacity for the means of egress from the storm shelter is directly to the exterior of the building.

(IS-STM 06-04-18 AM, IS-STM 01-02-18 AM-CC)

**603.1.1 Doors and shutters.** Where the applicable building code does not require a rated assembly, fire rated doors and shutters serving the *community storm shelter* are not required to be self or automatic closing where the opening is protected in accordance with Section 306.

**SECTION ~~604~~ 602**  
**FIRE EXTINGUISHERS**

**(IS-STM 05-05-18 AM)**

**604.1 ~~602.1~~ General.** A fire extinguisher shall be required within each story of all community storm shelters.

**604.2 ~~602.2~~ Requirements.** Fire extinguishers shall meet the requirements of NFPA 10. Installation of fire extinguishers shall not compromise the structural or missile impact performance of the exterior storm shelter envelope.

(IS-STM 07-18-18 AS)

## CHAPTER 7

# **STORM SHELTER ESSENTIAL FEATURES AND ACCESSORIES**

### **SECTION 701 GENERAL**

(IS-STM 07-02-18 AM/D, IS-STM 07-01-18 AM, IS-STM 07-18-18 AS)

**701.1 Protection of storm shelter critical support systems.** Storm shelter critical support systems shall remain functional for the design storm event and minimum period of storm shelter occupancy (24 hours for hurricane shelters, 2 hours for tornado shelters). Storm shelter critical support systems located outside of the storm shelter areas shall be protected by a means that meets the wind pressure and missile impact requirements of Chapter 3, and, as applicable, the flood-resistance requirements of Chapter 4.

### **SECTION 702 TORNADO SHELTERS**

(IS-STM 03-21-18 AM) (IS-STM 07-19-18) (IS-STM 01-02-18 AM-CC)

**702.1 Exterior weather protection of tornado shelters.** All exposed components and cladding assemblies and roof coverings of tornado shelters shall meet the requirements of the applicable code.

(IS-STM 05-14-19 AM/AFM)

**702.1.1 Door Weather Seal.** Doors in the shelter envelope that are also exterior doors to the building shall have a weather seal provided at the undercut.

(IS-STM 07-08-18 AS, IS-STM 07-18-18 AS)

**702.2 Sanitation facilities stations.** Toilet and hand-washing facilities shall be located within the tornado shelter area and provided in the minimum number shown in Table 702.2. Each tornado shelter area shall be provided with toilets and hand-washing stations in accordance with Table 702.2. The required toilets and hand-washing stations shall be located within the tornado shelter area.

(IS-STM 07-08-18 – AS, IS-STM 07-09-18-AM, IS-STM 07-18-18 AS, IS-STM 10-09-18 AS)

**TABLE 702.2**

**REQUIRED SANITATION FACILITIES STATIONS, TORNADO SHELTERS**

<b>STORM <u>TORNADO SHELTER</u> TYPE</b>	<b>TOILET FACILITIES STATIONS</b>	<b>HAND-WASHING FACILITIES STATIONS</b>
Residential, one- and two-family dwellings	Not Required	Not Required
Residential, other	1	Not Required
Community ( <del>≤50</del> <u>50 occupants)	1	Not Required
Community (> <del>50</del> >= <u>50</u> occupants)	<del>2</del> minimum <u>1</u> per 250 for the first 500 occupants and 1 additional per 500 occupants or portions thereof >500 occupants	1 per 1000 occupants

(IS-STM 07-08-18 – AS, IS-STM 07-18-18 AS)



**702.2.1 Required toilets and hand-washing facilities stations.** Sanitation facilities stations provided for the normal occupancy installed within the *tornado shelter* shall be included in the overall *tornado shelter* sanitation facility count.

**(IS-STM 07-08-18 – AS, IS-STM 07-10-18 AS, IS-STM 07-18-18 AS)**

**702.2.2 Additional facilities sanitation stations for storm tornado shelters.** Where the required number of sanitation facilities stations for the *tornado shelter* exceeds the number of facilities stations provided for the normal occupancy of the space, the additional facilities shall be permitted to be temporary sanitary fixtures stations, such as chemical toilets or other means approved by the authority having jurisdiction.

**(IS-STM 07-09-18 AM)**

**702.2.3 Urinals.** Urinals shall be permitted to be substituted for water closets in accordance with the International Plumbing Code Section 424.

**(IS-STM 07-09-18 AM)**

**702.2.4 Fixture calculations.** The number of fixtures for each sex shall be allocated in accordance with the International Plumbing Code Section 403.1.1.

**(IS-STM 05-03-18 AM, IS-STM 07-19-18)**

**702.2.5 Toilet station privacy.** Each toilet station shall occupy a separate compartment with walls, partitions, curtains or equivalent that enclose the fixtures to ensure privacy.

**(IS-STM 07-08-18 – AS, IS-STM 07-19-18)**

**702.2.6 702.2.3 Sanitation facilities support systems.** Support systems for the sanitation facilities and stations (e.g., bladders, storage tanks or vessels, etc.) shall be capable of supplying water and containing waste for the design capacity of the *tornado shelter*.

**(IS-STM 07-19-18)**

**702.2.7 702.2.4 Conversion of plumbing systems.** Plumbing and valve systems of fixtures located within the *tornado shelter* shall be permitted to be designed for conversion to emergency operation to meet the required demand.

**(IS-STM 07-19-18 AS, IS-STM 07-03-18 AM)**

**702.3 702.4 Ventilation.** Occupied space in *tornado shelters* shall be ventilated by natural means provided with *natural ventilation* in accordance with Section 702.1.4-702.3.1 or by with mechanical ventilation in accordance with Section 702.1.2 702.3.2. Openings used for atmospheric pressure change (APC) are permitted to be counted as ventilation for the purposes of this section. Ventilation openings for natural and mechanical ventilation shall comply with Section 702.3.3 and 702.3.4.

**(IS-STM 07-17-18 AM, IS-STM 07-19-18 AS)**

**702.1.4 702.3.1 Natural ventilation.** *Tornado shelters that rely on natural ventilation shall be provided with the minimum ventilation area in accordance with Table 702.1.4 702.3.1.*

**(IS-STM 07-17-18 AM, IS-STM 07-19-18 AS, IS-STM 10-09-18 AS)**

**TABLE 702.1.4 702.3.1**

**VENTING AREA REQUIRED FOR TORNADO SHELTERS**

<b>TORNADO SHELTER TYPE</b>	<b>VENTING AREA (PER OCCUPANT)</b>
Residential	2* square inches
Community (≤50 <50-occupants)	5 square inches
Community (>50 ≥=50 occupants)	6 square inches

\* See exception to Section 702.1.4.4 702.3.1.1.

For SI: 1 square inch = 645.2 mm<sup>2</sup>.

**(IS-STM 07-17-18 AM, IS-STM 07-04-18 AM; IS-STM 05-05-18 AM, IS-STM 07-18-18 AS, IS-STM 07-19-18 AS)**

**702.1.1.1 702.3.1.1 Location of ventilation openings.** Configuration of *natural ventilation* openings required for *tornado shelters* shall be such that a minimum of 25 percent of the required area is located within 46 inches (2581 mm) of the floor, or in the lower one-half of the height of the *tornado* shelter, whichever is less, with the balance, but not less than 50 percent of the required area located a minimum of 72 inches (1829 mm) above the floor, or in the upper one-fourth of the height of the *tornado* shelter, whichever is greater. Lower and upper openings shall be horizontally dispersed and located on an opposite wall walls or the roof surface surfaces to provide cross ventilation of the *tornado shelter*. For tornado shelters with multiple stories, *natural ventilation* openings shall be provided for the occupants served for each story.

**Exception:** Air intake openings for *residential tornado shelters* shall be permitted to be located entirely in the upper half of the *tornado* shelter provided that the venting area is increased to 4 square inches (1290 mm<sup>2</sup>) per *tornado* shelter occupant.

(IS-STM 07-17-18 AM, IS-STM 07-19-18 AM)

**702.3.1.2 Mechanical vents.** Mechanical vents, louvers or dampers used to close *natural ventilation* openings shall be connected to a standby power system.

(IS-STM 07-03-18 AM, IS-STM 07-13-18 AM, IS-STM 07-17-18 AM, IS-STM 01-02-18 AM; IS-STM 07-05-18 AM, IS-STM 07-19-18 AS)

**702.3.2 702.1.2 Mechanical ventilation.** *Tornado shelters* that rely on mechanical ventilation shall be provided with the minimum mechanical ventilation rate of required outdoor air at a minimum rate of 5 cubic feet per minute per occupant for the *storm shelter occupant load* in accordance with the *applicable* building code provisions for the normal use of the space. The mechanical ventilation system shall be connected to an emergency a standby power system.

(IS-STM 07-06-18 – AM, IS-STM 07-17-18 AM, IS-STM 07-19-18 AS)

**702.3.3 702.1.3 Intake openings.** Outside air intake openings ~~located in the same wall~~ shall be located separated a minimum of 10 feet (3048 mm) horizontally ~~and separated~~ from any hazardous or noxious contaminant, such as ~~emergency or back-up generator vents or exhaust, fuel storage tank vents and containers, maintenance or custodial storage facilities.~~

(IS-STM 07-17-18 AM, IS-STM 07-18-18 AS, IS-STM 07-19-18 AS, IS-STM 06-04-18 AM)

**702.3.4 702.1.4 Exhaust or intake opening protection.** Air exhaust or intake openings that terminate outside of *occupied storm shelter areas* and *occupant support areas* shall comply with the provisions of Section 306.3 for exterior wall and roof *impact-protective systems*. Ventilation openings that penetrate the *storm shelter envelope* between the host building and *storm shelter* shall also comply with the provisions of Section 603.

(IS-STM 07-13-18 AM, IS-STM 07-18-18 AS CC, IS-STM 07-19-18 AS)

**702.4 Standby power.** Where required by Section 702.3 or 702.7, *community tornado shelters* shall be provided with a standby power system. The standby power system shall support *occupied storm shelter areas* and *occupant support areas*.

(IS-STM 07-13-18 AM, IS-STM 07-17-19 AM, IS-STM 07-19-18 AS)

**702.4.1 702.3.4 Capacity.** The ~~emergency electrical~~ standby power system shall have adequate capacity and rating to supply all required systems and circuits for standby lighting and any mechanical ventilation systems intended to be operated at one time.

(IS-STM 07-13-18 AM, IS-STM 07-17-19 AM, IS-STM 07-19-18 AS)

**702.4.2 702.3.2 Duration.** The ~~emergency electrical~~ standby power system shall be designed to provide continuously the required output capacity for a minimum of 2 hours.

**Exception:** Personal use flashlights shall be permitted for the ~~emergency~~ standby lighting system requirement for *tornado shelters* with an occupant load of less than or equal to 50, when provided at a quantity not less than one (1) flashlight per 10 occupants. ~~Personal use flashlights shall be a minimum of two “D” cell size or equivalent light output, and readily accessible from within the occupied shelter areas or immediately adjacent occupant support areas.~~

(IS-STM 07-17-18 AM, IS-STM 07-19-18 AS)

**702.4.3 Protection of components.** Standby power supply, transformers, distribution panels, cabling, fuel supply storage tanks, fuel lines and power supply to *critical support system* components shall be protected in accordance with Section 701.1.

(IS-STM 03-22-18 AM, IS-STM 07-19-18 AS)

**702.5 Electrical grounding and bonding of *tornado shelters*.** Exposed metal surfaces within *tornado shelters* shall be electrically bonded and grounded where required by Article 250 of NFPA 70 or by the *authority having jurisdiction*.

(IS-STM 07-17-18 AFM, IS-STM 07-19-18 AS)

**702.6 Exit signs and emergency lighting.** In *community tornado shelters*, in the event of a power supply failure, an emergency power system shall supply power for the exit signs and the emergency exit lighting in accordance with the *International Building Code*.

(IS-STM 07-13-18 AM, IS-STM 07-17-18 AM, IS-STM 05-18-18 AM, IS-STM 07-19-18 AS, IS-STM 07-18-18 AS)

**702.3 702.7 Emergency Standby lighting.** *Community tornado shelters* shall be provided with an emergency standby lighting system. The emergency standby lighting system shall provide an average illumination levels of not less than 1 foot-candle (11 lux) of illumination at the walking surface in occupied *storm shelter areas*, and *occupant support areas*, required corridors, passageways and means of egress. The standby lighting system shall be connected to a standby power system.

**Exception:** Personal-use flashlights shall be permitted for the standby lighting system requirement for *tornado shelters* with a *storm shelter design occupant capacity* of less than 50, when provided at a quantity not less than one (1) flashlight per 10 occupants. Personal-use flashlights with a minimum of 150 lumens or an approved equivalent lighting device, and readily available within the *occupied storm shelter areas* or immediately adjacent *occupant support areas*.

(IS-STM 07-12-18 AM, IS-STM 07-19-18 AS)

**702.4 702.8 First aid kit.** A first aid kit shall be supplied in all *community tornado shelters* with a shelter occupant load of greater than 50 that complies with ANSI/ISEA I Z308.1, Class A First Aid Kit.

## SECTION 703 HURRICANE SHELTERS

(IS-STM 03-21-18 AM, IS-STM 07-19-18 AS)

**703.1 703.9 Exterior weather protection of *hurricane shelters*.** All exposed components and cladding assemblies and roof coverings of *hurricane shelters* shall be designed to resist rainwater penetration during the design windstorm and shall be designed and installed to meet the wind load requirements of Section 304.

(IS-STM 05-14-19 AM/AFM)

**703.1.1 Door Weather Seal.** Doors in the shelter envelope that are also exterior doors to the building shall have a weather seal provided at the undercut.

(IS-STM 07-08-18 – AM, IS-STM 07-18-18 AS **CC**)

**703.2 Sanitation facilities stations.** Toilet and hand-washing facilities shall be located within the storm shelter area and provided in the minimum number shown in Table 703.2. Each *hurricane shelter* area shall be provided with toilets and hand-washing stations in accordance with Table 703.2. The required toilets and hand-washing stations shall be located within the *hurricane shelter* area.

(IS-STM 07-08-18 AM, IS-STM 07-18-18 AS, IS-STM 10-09-18 AS)

### TABLE 703.2 REQUIRED SANITATION FACILITIES STATIONS FOR HURRICANE SHELTERS

<b>HURRICANE SHELTER TYPE</b>	<b>TOILET FACILITIES STATIONS</b>	<b>HAND-WASHING FACILITIES STATIONS</b>
Residential, one-and two-family dwellings	Not Required	Not Required
Residential, other	1	Not Required
Community shelters ( $\leq 50$ occupants)	1	Not Required
Community shelters ( $\geq 50$ occupants)	1 per 50 occupants	1 per 100 occupants

**(IS-STM 07-08-18 – AM, IS-STM 07-18-18 AS)**

**703.2.1 Required toilets and hand-washing facilities.** Sanitation facilities provided for the normal occupancy installed within the *hurricane shelter* shall be included in the overall *hurricane shelter* sanitation facility station count.

**(IS-STM 07-08-18 – AM, IS-STM 07-18-18 AS)**

**703.2.2 Additional facilities sanitation stations for storm hurricane shelters.** Where the required sanitation facilities stations for the *hurricane shelter* exceed the required number of facilities provided for the normal occupancy of the space, the additional facilities stations shall be permitted to be temporary sanitary fixtures, chemical toilets or other means that are deemed acceptable by the *authority having jurisdiction*.

**(IS-STM 07-09-18 AM)**

**703.2.3 Urinals.** Urinals shall be permitted to be substituted for water closets in accordance with the International Plumbing Code Section 424.

**(IS-STM 07-09-18 AM)**

**703.2.4 Fixture calculations.** The number of fixtures for each sex shall be allocated in accordance with the International Plumbing Code Section 403.1.1.

**(IS-STM 05-03-18 AM, IS-STM 07-19-18 AS)**

**703.2.3 703.2.5 Toilet station privacy.** Each toilet station shall occupy a separate compartment with walls, partitions, curtains or equivalent that enclose the fixtures to ensure privacy.

**(IS-STM 07-08-18 – AM, IS-STM 07-18-18 AS, IS-STM 07-19-18 AS)**

**703.2.6 703.2.3 Sanitation facilities support systems.** Support systems for the sanitation facilities and stations (e.g., bladders, storage tanks or vessels, etc.) shall be capable of supplying water and containing waste for the design capacity of the *storm hurricane shelter*.

**703.3 Water supply and storage.** The capacity of plumbing and waste disposal systems to supply potable water and contain or dispose of waste water or solid wastes shall be determined in accordance with Table 703.3.

**(IS-STM 07-18-18 AS, IS-STM 10-09-18 AS)**

**TABLE 703.3  
WATER SUPPLY AND WASTE WATER STORAGE HURRICANE SHELTERS**

<b>STORM HURRICANE SHELTER TYPE</b>	<b>POTABLE WATER</b>	<b>WASTE WATER</b>
Residential, one- and two-family dwellings	Not Required	Not Required
Residential, other	Not Required	Not Required
Community ( $\leq 50$ occupants)	Not Required	Not Required

Community ( <del>&gt;50</del> $\geq 50$ occupants)	1 gallon per occupant	1.5 gallons per occupant
----------------------------------------------------	-----------------------	--------------------------

For SI: 1 gallon = 3.785 L.

**(IS-STM 07-19-18 AS)**

**703.4 ~~703.8~~ Rainwater drainage for hurricane shelter facilities.**

**(IS-STM 03-04-18 AFM, IS-STM 07-19-18 AS)**

**703.4.1 ~~703.8.4~~ Rainfall rate for the primary roof drainage system.** Rainfall rate for the primary roof drainage system of a *hurricane shelter* shall be determined by adding 3 inches (76.2 mm) of rainfall per hour to the 100-year, 1-hour rainfall rate. The 100-year, 1 hour rainfall rate shall be determined from Figure ~~303.2~~ 303.1.1 or from approved local weather data.

**(IS-STM 03-04-18 AFM, IS-STM 07-19-18 AS)**

**703.4.2 ~~703.8.2~~ Rainfall rate for the secondary (overflow) drainage systems.** The rainfall rate for the secondary (overflow) drainage systems shall be determined by adding 6 inches (152.4 mm) of rainfall per hour to the 100-year, 1-hour rainfall rate. The 100-year, 1 hour rainfall rate shall be determined from Figure ~~303.2~~ 303.1.1 or from approved local weather data.

**(IS-STM 03-04-18 AFM, IS-STM 07-16-18 AS, IS-STM 10-05-18 AM, IS-STM 07-01-18 AM, IS-STM 07-18-18 AS, IS-STM 07-19-18 AS)**

**703.4.3 ~~703.8.3~~ Rainwater drainage for hurricane shelter facilities.** Rainwater drainage shall be provided for *hurricane shelter* facilities where ~~it is possible~~ that rainwater will be impounded and flood *occupied storm shelter areas, occupant support areas and storm shelter critical support systems* or access routes. The rainfall rate shall be determined by adding 6 inches (152.4 mm) per hour to the 100-year, 1-hour rainfall rate. The 100-year, 1 hour rainfall rate shall be determined from Figure ~~303.2~~ 303.1.1 or from approved local weather data.

**(IS-STM 07-03-18 AM, IS-STM 07-17-18 AM, IS-STM 05-18-18 AM, IS-STM 07-19-18 AS)**

**703.5 ~~703.4~~ Ventilation.** ~~Every occupied~~ Occupied space in *community hurricane shelters* with an ~~occupant load~~ storm shelter design occupant capacity of 50 or greater than 50 shall be ventilated by mechanical means in accordance with Section ~~703.4.4~~ 703.5.2. All *hurricane shelters* shall be provided with *natural ventilation* in accordance with Section ~~703.4.2~~ 703.5.1. Ventilation openings for natural and mechanical ventilation shall comply with Section ~~703.5.3~~ and ~~703.5.4~~.

**(IS-STM 07-03-18 – AM, IS-STM 07-19-18 AS)**

**703.1.1 Mechanical ventilation.** (relocated)

**(IS-STM 07-03-18 AM, IS-STM 07-17-18 AM, IS-STM 07-18-18 AS, IS-STM 07-19-18 AS)**

**703.5.1 ~~703.1.2~~ Natural ventilation.** All *hurricane shelters* shall be provided with openings to facilitate minimum *natural ventilation* in accordance with this section. The area of ventilation openings shall comply with Table ~~703.4~~ 703.5.1, and the location of openings shall be in accordance with Section ~~703~~. Where *hurricane shelters* are also designed as *tornado shelters*, openings provided to relieve internal pressure for atmospheric pressure change (APC) per Section 304.7 shall be permitted to be counted as *natural ventilation* openings.

**(IS-STM 07-03-18 AM, IS-STM 07-19-18 AS, IS-STM 10-09-18 AS)**

**TABLE ~~703.4~~ 703.5.1  
VENTING AREA REQUIREMENTS FOR HURRICANE SHELTERS**

SHELTER TYPE	VENTING AREA (PER OCCUPANT)
Residential	4 square inches
Community ( $\leq 50$ <del>&lt;50</del> -occupants)	8 square inches
Community ( <del>&gt;50</del> $\geq 50$ occupants)	12 square inches

For SI: 1 square inch = 645.2 mm<sup>2</sup>.

**(IS-STM 07-03-18 AM; IS-STM 07-04-18 AM; IS-STM 05-05-18 AM, IS-STM 07-18-18 AS, IS-STM 07-19-18 AS)**  
~~703.1.3~~ **703.5.1.1 Location of ventilation openings.** Configuration of *natural ventilation* openings required for *hurricane shelters* shall be such that a minimum of 25 percent of the required area is located within 46 inches (1168 mm) of the floor, or in the lower one-half of the height of the *hurricane* shelter, whichever is less, with the balance, but not less than 50 percent of the required area, located a minimum of 72 inches (1829 mm) above the floor, or in the upper one-fourth of the height of the *hurricane* shelter, whichever is greater. Lower and upper openings shall be horizontally dispersed and located on an opposite wall walls or the roof surface surfaces to provide cross ventilation of the *hurricane shelter*. For hurricane shelters with multiple stories, *natural ventilation* openings shall be provided for the occupants served for each story.

**(IS-STM 07-17-18 AM, IS-STM 07-19-18 AS)**  
~~703.1.6~~ **703.5.1.2 Mechanical vents.** Mechanical vents, louvers or dampers used to close *natural ventilation* openings shall be connected to a standby power system.

**(IS-STM 07-03-18 – AM, IS-STM 07-13-18 AM, IS-STM 01-02-18 AM, IS-STM 07-04-18 AM, IS-STM 07-19-18 AS)**  
~~703.5.2~~ ~~703.1.4~~ **Mechanical ventilation.** The minimum mechanical ventilation rate of required outdoor air shall be determined at a minimum rate of 5 cubic feet per minute per occupant for the *storm shelter occupant load* in accordance with the *applicable* building code provisions for the normal use of the space. The mechanical ventilation system shall be connected to a standby power system.

**(IS-STM 07-03-18 AM, IS-STM 07-06-18 AM, IS-STM 07-19-18 AS)**  
~~703.5.3~~ ~~703.1.4~~ **Intake openings.** Outside air intake openings ~~located in the same wall~~ shall be located separated a minimum of 10 feet (3048 mm) horizontally and separated from any hazardous or noxious contaminant, such as ~~emergency or back-up~~ generator vents or exhaust, fuel storage tank vents and containers, maintenance or custodial storage facilities.

**(IS-STM 07-03-18 AM, IS-STM 07-18-18 AS, IS-STM 07-19-18 AS, IS-STM 06-04-18 AM)**  
~~703.5.4~~ ~~703.1.5~~ **Exhaust or intake opening protection.** Air exhaust or intake openings that terminate outside of *occupied storm shelter areas* and *occupant support areas* shall comply with the provisions of Section 306.3 for exterior wall and roof *impact-protective systems*. Ventilation openings that penetrate the *storm shelter envelope* between the host building and *storm shelter* shall also comply with the provisions of Section 603.

**(IS-STM 07-13-18 AM, IS-STM 07-01-18 AM, IS-STM 07-18-18 AS, IS-STM 07-19-18 AS)**  
**703.6 Standby power.** ~~Where required by Sections 703.1 or 703.4-703.5 or 703.9, *Community hurricane shelters* with a shelter occupant load greater than 50 shall be provided with a standby electrical power system. The standby electrical power system shall support occupied hurricane *storm shelter areas*, and *occupant support areas* and *storm shelter* critical support systems. At a minimum, the standby electrical power system shall supply power to life safety systems and critical branch lighting circuits. Where required by the authority having jurisdiction, the standby electrical power system shall also supply power to selected HVAC circuits.~~

**(IS-STM 07-13-18 AM)**  
**703.6.1 Capacity.** The standby ~~electrical~~ power system shall have adequate capacity and rating to supply all required systems and circuits for standby lighting and any mechanical ventilation systems intended to be operated at one time.

**(IS-STM 07-13-18 AM)**  
**703.6.2 Duration.** The standby ~~electrical~~ power system shall be designed to provide continuously the required output capacity for a minimum of 24 hours.

**(IS-STM 07-13-18 AM)**  
**703.6.3 Independence.** The standby ~~electrical~~ power supply shall be located *on-site*, and shall be independent of off-site sources of fuel or water.

**(IS-STM 07-13-18 AM, IS-STM 07-14-18-AM)**

**703.6.4 Protection of components.** Standby electrical power supply, transformers, distribution panels, cabling, fuel supply storage tanks, fuel lines and ~~power supply to other~~ critical support system components shall be protected from design event conditions in accordance with Section 701.1.

(IS-STM 07-13-18 AM)

**703.6.5 Location.** Standby electrical power supply shall be accessible by a protected access route. The access route shall be located within the *hurricane shelter* or shall meet the provisions for exterior wall and roof *impact-protective systems* in accordance with this standard.

(IS-STM 03-22-18 AM, IS-STM 07-19-18 AS) **errata**

**703.7 703.9 Electrical grounding and bonding of hurricane shelters.** Exposed metal surfaces within *hurricane shelters* shall be electrically bonded and grounded ~~shall be electrically connected to the hurricane shelter's grounding electrode system where such grounded electrode systems exists where required by Article 250 of NFPA 70 or by the authority having jurisdiction.~~

(IS-STM 07-17-18 AFM, IS-STM 07-19-18 AS)

**703.8 Exit signs and emergency lighting.** In *community hurricane shelters*, in the event of a power supply failure, an emergency power system shall supply power for the exit signs and the emergency exit lighting in accordance with the International Building Code.

(IS-STM 07-13-18 AM, IS-STM 07-17-18 AM, IS-STM 05-18-18 AM, IS-STM 07-18-18 AS, IS-STM 07-19-18 AS)

**703.4 703.9 Emergency Standby lighting.** *Community hurricane shelters* shall be provided with an emergency standby lighting system. The emergency standby lighting system shall provide an average illumination levels of not less than 1 foot-candle of illumination (11 lux) at the walking surface in *occupied storm shelter areas*, and *occupant support areas*, ~~required corridors, passageways and means of egress.~~ The standby lighting system shall be connected to a standby power system.

**Exception:** Personal-use flashlights shall be permitted for the standby lighting system requirement for *tornado shelters* with an occupant load a *storm shelter design occupant capacity* less than or equal to 50, when provided at a quantity not less than one (1) flashlight per 10 occupants. Personal-use flashlights with shall be a minimum of two "D" cell size 150 lumens or an approved equivalent lighting device light output, and readily available accessible from within the *occupied storm shelter areas* or immediately adjacent *occupant support areas*.

(IS-STM 07-13-18 AM)

**703.5 Standby lighting.** *Community hurricane shelters* with a shelter occupant load greater than 50 shall be provided with a standby lighting system. The standby lighting system shall provide an average of 10 footcandles illumination (110 lux) in *occupied shelter areas*, *occupant support areas*, ~~required corridors, passageways and means of egress.~~

(IS-STM 07-12-18 AM, IS-STM 07-19-18 AS)

**703.7 703.10 First aid kit.** A first aid kit shall be supplied in all *community hurricane shelters* that complies with ANSI/ISEA I Z308.1, Class A First Aid Kit.

**Exception:** A first aid kit is not required where equivalent first aid supplies are located in the building.

## CHAPTER 8

# TEST METHODS FOR IMPACT AND PRESSURE TESTING

### SECTION 801 GENERAL

(IS-STM 08-20-18 AM)

**801.1 Scope.** This testing protocol covers procedures for conducting impact and pressure testing of components of the *storm shelter envelope* required to meet wind-borne debris impact provisions, as detailed in Section 305 of this standard.

(IS-STM 08-16-18 AS)

### SECTION 802 TERMINOLOGY

(IS-STM 08-16-18 AS)

**802.1 General terminology.** General terminology of building construction used in this test method is defined in ASTM E634.

(IS-STM 08-16-18 AS)

~~802.2 Definitions of terms specific to this test method.~~

(IS-STM 08-16-18 AS) *(deleted in favor of definition in Section 202)*

~~**IMPACT-PROTECTIVE SYSTEM.** A system or device such as a shutter, door or other device mounted on the inside or outside of the exterior wall of a *shelter* that has been demonstrated by testing to be capable of withstanding the impact of test missiles as detailed in this standard.~~

(IS-STM 08-16-18 AS) *(relocated to 202)*

~~**SPECIMEN.** The entire assembled unit submitted for test, including but not limited to anchorage devices and structure to which product is to be mounted.~~

(IS-STM 08-16-18 AS) *(relocated to 202)*

~~**TEST CHAMBER.** An airtight enclosure of sufficient depth to allow unobstructed deflection of the specimen during pressure cycling, including ports for air supply and removal, and equipped with instruments to measure test pressure differentials.~~

### SECTION 802 803 TEST SPECIMENS

(IS-STM 08-01-18 AM, IS-STM 08-02-18 AS, IS-STM 08-03-18 AS, IS-STM 10-04-18 AS, IS-STM 08-18-18 AS, IS-STM 08-22-18 AM, IS-STM 08-23-18 AS)

**802.1 803.1 Test assembly.** All parts of the test *specimen* shall be full size, using the same materials, details, methods of construction and methods of attachment as proposed for actual use. Testing of components consisting of wall assemblies, roof assemblies, ~~door or window assemblies~~ or other impact protective systems shall be allowed in lieu of testing entire *storm shelters*. ~~Where failure of framing members controls the impact performance, wall and roof sections assemblies~~ subjected to ~~debris impact pressure testing and wall sections where impact resistance may be controlled by framing members~~ shall be a minimum of 4 feet (1219 mm) wide and the full length of the span of the wall or roof section from support to support. ~~Except~~ Where failure of framing members may has been shown through testing to not control the impact performance, wall and roof sections subjected to debris impact testing shall be a minimum of 4 feet (1219 mm) wide by 4 feet (1219 mm) high unless dimensions of the actual assembly are less than these dimensions.

~~Doors, windows and Impact-protective systems are to~~ shall be impact tested and cyclic tested where applicable, tested at the maximum and minimum size listed for use. Static pressure testing shall be conducted on the maximum



size listed for use. Operable doors or windows door assemblies and window assemblies shall be tested for the conditions of swing and latching including inward or outward swing separately as specified for use of the product. Impact-protective systems shall be static pressure tested in both directions unless a clear worst-case direction is determined by the test laboratory. Paired doors and their latching hardware shall be tested independently from single doors. The specimen shall consist of the entire assembled unit and shall, when where practical, be mounted as it will be installed in a storm shelter, and shall contain all devices used to resist wind forces and wind-borne debris. When Where it is not practical to install for testing a doors or windows door assemblies and window assemblies as it will be mounted in a storm shelter, then the unit or assembly shall be mounted in a test buck to connect the specimen to the test frame/stand/chamber frame, stand or test chamber. Details of the mounting shall be described in the test report.

**802.2 803-2 Number of test specimens.** Where both pressure and impact tests are required, testing of a single specimen subjected separately to each effect or two specimens, one subject to each load effect, shall be permitted.

**802.3 803-3 Specimen conditioning.** Samples shall be conditioned at ambient temperature [59° to 95° F (15° to 35° C)] for a minimum of 2 hours prior to testing.

(IS-STM 02-09-18 AM) (IS-STM 08-20-18 AM)

**802.4 803-4 Specifications/ and drawings.** The manufacturer or constructor shall provide the test laboratory with applicable product specifications and/or drawings detailing materials of construction and applicable installation details. The testing agency test laboratory shall verify conformance of the test specimen to the product specifications and/or drawings.

(IS-STM 06-04-18 AM)

**802.5 803-5 Fire-resistance testing.** The testing for fire-resistance materials required by Section 603 and pressure and impact tests in accordance with Chapter 8 shall be subjected to such tests separately. Testing on a separate specimen for fire resistance shall be permitted.

## **SECTION 803 804 MISSILE IMPACT TESTING**

(IS-STM 02-09-18 AM)

**803.1 804-1 Apparatus.** The general description of the apparatus for performing the missile impact testing requirements of this standard is detailed in Section 6 of ASTM E1886. Any equipment, properly certified, calibrated and approved by a qualified lab test laboratory capable of performing this test within the allowable tolerance is permitted.

**803.2 804-2 Calibration.** Calibration of the speed measuring system shall be performed per the procedure detailed in Section 9 of ASTM E1886.

**803.3 804-3 Missile impact procedure.** Test specimens shall be impact tested with test missiles of size and speed as specified in Section 305 of this standard. Impact procedure shall be performed as detailed in Sections 11.1 through 11.3 of ASTM E1886. The minimum number of impact locations shall be as detailed in Section 803.9 804-9.

**803.4 804-4 Missile properties.** The test missile weight shall be selected to meet the requirements of Section 305 of this standard and shall comply with Sections 803.4.1 804.4.4 through 803.4.3 804.4.3.

**803.4.1. 804.4.1 Wood species.** Any common softwood lumber species as defined by DOC PS 20 shall be permitted to be used provided it meets length tolerances detailed below. The lumber shall be grade stamped No. 2 or better and be free of splits, checks, wane or other significant defects. The 2 by 4s used shall be straight such that any bow or warp measured by stretching a string or wire on the side of the board from end to end is within 0.5 inch of the 2 by 4s surface over its entire length.

(IS-STM 08-04-18 AM, IS-STM 10-04-18 AS)

**803.4.2 804.4.2 Missile length and weight tolerance.** The wood density, including moisture content, shall be such that the required 15 ± 0.25 pound (6.8 ± 0.11 kg) weight is met with a length of 13.5 and the 9 ± 0.25 pound (4.1 ± 0.11 kg) weight is met with a length of 8 feet ± 4 inches (2438 mm ± 102 mm). between 10 feet (3048 mm) and 15

feet (4572 mm). The  $9 \pm 0.25$  pound (4.1 + 0.11 kg) weight is met with a length between 6 feet (1829 mm) and 10 feet (3048 mm). The sabot and attachment screws shall be included in the missile weight ~~when~~ where it is permanently attached. Missile weights shall be confirmed within 2 hours prior to their use.

**803.4.3 804.4.3 Conditioning.** The test missile shall be conditioned at ambient temperature [59°F to 95°F (15°C to 35°C)] for a minimum of 2 hours prior to testing.

**803.5 804.5 Sabot size and weight.** Where the missile launching system requires the use of a sabot for the effective launching of the missile, the sabot shall weigh no more than  $\frac{1}{2}$  pound (0.226 kg), and shall be included in the weight of the missile, unless it is stripped away during flight prior to impact.

**803.6 804.6 Missile speed.** Missile speed measurement and speed tolerances shall be in accordance with the following:

**803.6.1 804.6.1 Missile speed measurement.** The missile speed shall be measured by a device capable of measuring the missile velocity to within  $\pm 1$  foot per second (0.305 m/s).

**803.6.2 804.6.2 Missile speed tolerance.** The missile test speed tolerance is 4 mph above and 0 mph below the missile speed prescribed in Section 305.

**803.7 804.7 Impact angle.** Missile impacts shall be within 5 degrees of normal to the primary plane of the test *specimen*. This requirement is deemed to be met when the barrel of the cannon is aligned within  $\pm 2$  degrees of perpendicular in the horizontal plane and between level and a 3-degree upward incline in the vertical plane.

**803.8 804.8 Testing temperature.** The testing shall be conducted at ambient temperature in the range of [59°F to 95° F (15°C to 35°C)].

**(IS-STM 08-17-18 AS, IS-STM 08-19-18 AM)**

**803.9 804.9 Impact locations and the number of impacts.** For purposes of testing impact protective systems, impact ~~are to be located~~ locations and quantities shall be as indicated in in the following sections Sections 803.9.1 through 803.9.7.3, as applicable. The tolerance for impact locations shall be within a 2-1/2 inch (64 mm) radius circle, with the center of the circle located as indicated in Sections 803.9.1 through 803.9.7.3, as applicable.

**(IS-STM 10-04-18 AS, IS-STM 08-18-18 AS, IS-STM 08-21-18 AM, IS-STM 10-01-18 AM-CC)**

**803.9.1 804.9.1 Panel or framed walls/roofs wall assemblies and roof assemblies.** Sections of Panel or framed wall assemblies and roof assemblies sections shall be impacted in the center of the ~~wall/roof~~ section, and at one interface corner as detailed in Figures 803.9.1 804.9.4 (1) and 803.9.1 804.9.4 (2).

~~When~~ Where an interior stud or support is present, additional impacts shall be performed near the stud/ or support, and directly on the stud support, as detailed in Figures 803.9.1 804.9.4 (1) and 803.9.1 804.9.4 (2).

Interface joints used for attachment or joining at corners, at panel-to-panel sections, or at panel-to-roof shall be impacted directly on the interface joints as detailed in Figure 803.9.1 804.9.4 (2) for each type of joint.

~~When~~ Where a section contains lapped materials, the centered impact shall be adjusted to strike the center of any lap, and an additional impact shall be performed beside the lap on the panel that laps behind the seam as detailed in Figure 803.9.1 804.9.4 (2).

No more than three impacts shall be made on one *specimen*. Where more than three impacts are required, multiple identical test *specimens* shall be provided.

**Exception:** More than three impacts ~~may~~ shall be permitted to be made on a test *specimen* by mutual consent of ~~owner~~ test sponsor and *test laboratory*.

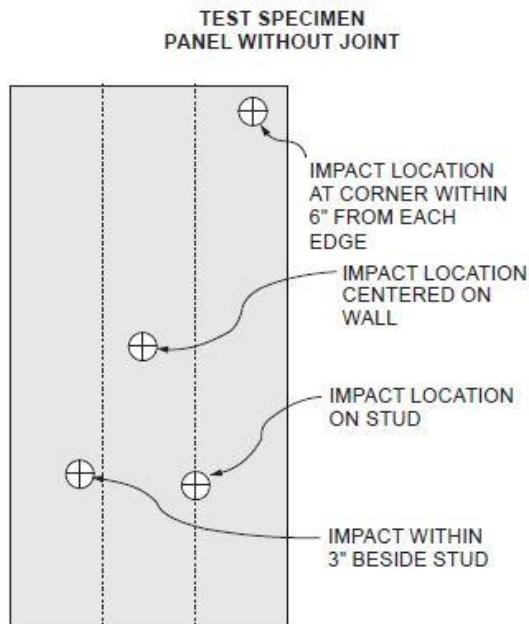

For SI: 1 inch = 25.4 mm.

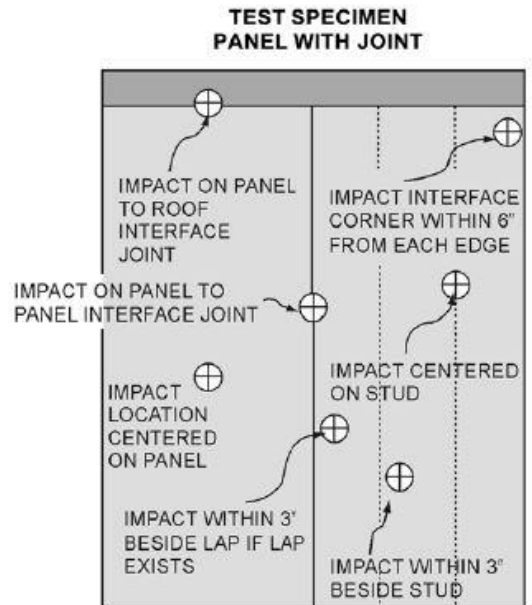

For SI: 1 inch = 25.4 mm.

(IS-STM 08-18-18 AS)

FIGURE ~~803.9.1~~ ~~804.9.1~~ (1)

**PANEL OR FRAMED WALLS/ROOF-WALL ASSEMBLIES AND ROOF ASSEMBLIES**

(IS-STM 08-18-18 AS)

FIGURE ~~803.9.1~~ ~~804.9.1~~ (2)

**PANEL OR FRAMED WALLS/ROOF-WALL ASSEMBLIES AND ROOF ASSEMBLIES**

(IS-STM 10-01-18 AM, IS-STM 10-04-18 AS, IS-STM 08-18-18 AS, IS-STM 08-21-18 AM)

**803.9.2** ~~804.9.2~~ **Solid wall assemblies and roof assemblies walls/roofs sections of concrete or other materials.** Sections of Wall assemblies and roof assemblies sections of solid concrete or other solid material shall be impacted in the center of the wall/roof section, and at one interface corner as detailed in Figures ~~803.9.2~~ ~~804.9.2~~ (1) and ~~803.9.2~~ ~~804.9.2~~ (2). ~~When~~ **Where** interface joints are used for joining at corners or panel-to-panel joints, an additional section shall be impacted directly on the interface joints as detailed in Figure ~~803.9.2~~ ~~804.9.2~~ (2).

Where an interior stud or support is present, additional impacts shall be performed within 3 inches (76.2 mm) of the stud/ ~~and~~ support, and directly on the stud support as detailed in Figures ~~803.9.2~~ ~~804.9.2~~ (1) and ~~803.9.2~~ ~~804.9.2~~ (2).

No more than three impacts shall be made on one *specimen*. Where more than three impacts are required, multiple identical test *specimens* shall be provided.

**Exception:** More than three impacts ~~may~~ **shall be permitted to be made on a test *specimen* by mutual consent of ~~owner~~ test sponsor and test laboratory.**

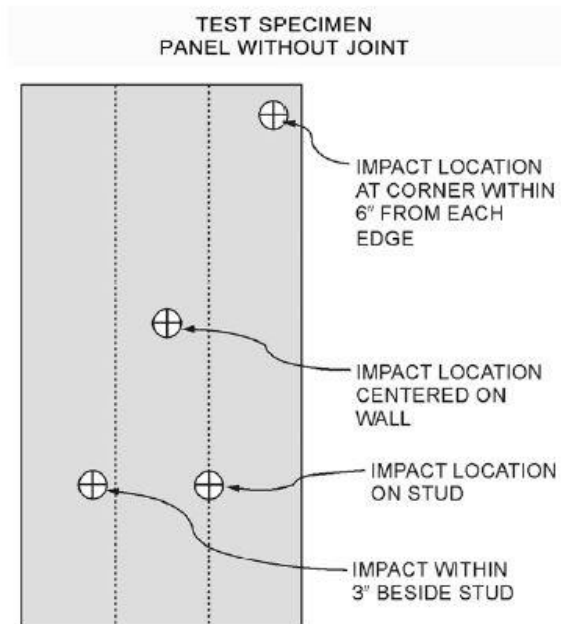

For SI: 1 inch = 25.4 mm.

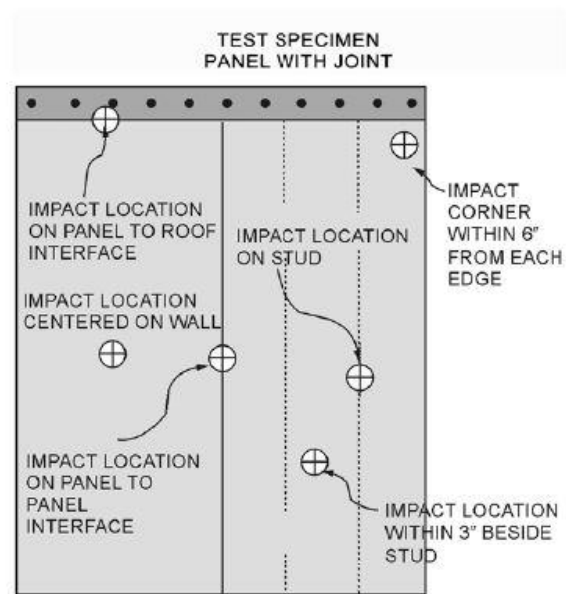

For SI: 1 inch = 25.4 mm.

(IS-STM 08-18-18 AS)

FIGURE ~~803.9.2~~ ~~804.9.2~~ (1)

**SOLID WALLS/ROOF SECTION WALL ASSEMBLIES AND ROOF ASSEMBLIES OF CONCRETE OR OTHER MATERIALS**

(IS-STM 08-18-18 AS)

FIGURE ~~803.9.2~~ ~~804.9.2~~ (2)

**SOLID WALLS/ROOF SECTION WALL ASSEMBLIES AND ROOF ASSEMBLIES OF CONCRETE OR OTHER MATERIALS**

(IS-STM 10-01-18 AM) (STM 08-18-18 AS) (IS-STM 08-21-18 AM)

**803.9.3** ~~804.9.3~~ **Masonry unit walls/roofs-wall assemblies and roof assemblies.** Walls and roof sections Section of wall assemblies and roof assemblies constructed of masonry units shall be impacted in the center of the wall/roof section, and at one interface corner or joint as detailed in Figure ~~803.9.3~~ ~~804.9.3~~ (1). Mortared joints shall be impacted directly on the interface joints as detailed in Figure ~~803.9.3~~ ~~804.9.3~~ (2).

No more than three impacts shall be made on one *specimen* or specimen panel. Where more than three impacts are required, multiple identical test *specimens* shall be provided.

**Exception:** More than three impacts ~~may~~ shall be permitted to be made on a test specimen by mutual consent of owner, test sponsor and test laboratory.

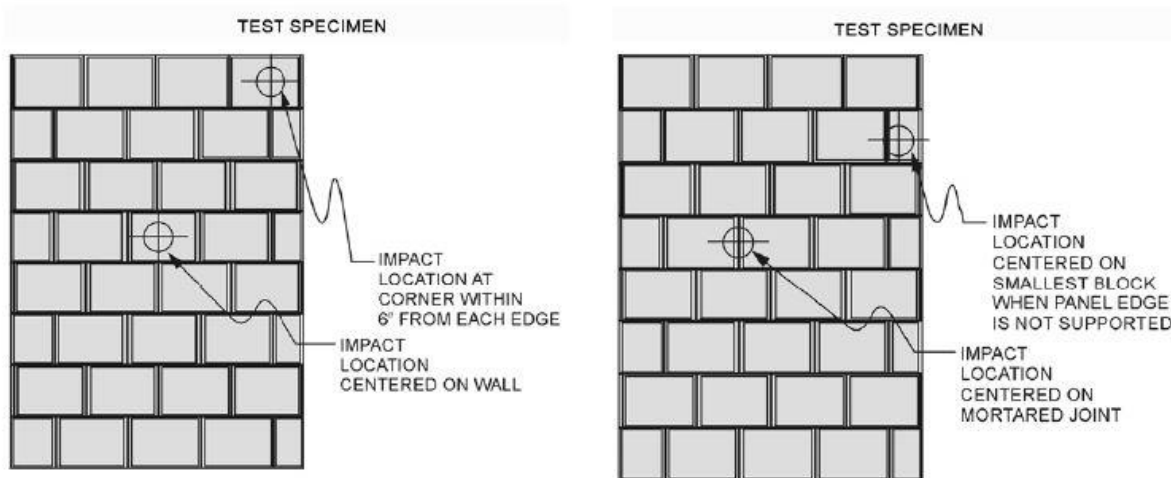

For SI: 1 inch = 25.4 mm.

(IS-STM 08-18-18 AS)

FIGURE 803.9.3 804.9.3 (1)

**MASONRY UNIT WALLS/ROOFS WALL ASSEMBLIES AND ROOF ASSEMBLIES**

(IS-STM 08-18-18 AS)

FIGURE 803.9.3 804.9.3 (2)

**MASONRY UNIT WALLS/ROOFS WALL ASSEMBLIES AND ROOF ASSEMBLIES**

(IS-STM 08-19-18 AM)

**804.9.5 803.9.4 Door assemblies.** Door assemblies shall comply with Section 804.9.5.1, 804.9.5.2 or 804.9.5.3 803.9.4.1, 803.9.4.2 or 803.9.4.3, as applicable. Glazed openings in doors shall comply with Section 804.9.5.4 803.9.4.4.

(IS-STM 08-17-18 AS) IS-STM 08-18-18 AS) (IS-STM 08-19-18 AM) (IS-STM 08-21-18 AM)

**803.9.4.1 804.9.5 Doors or other entry/egress systems Side-swinging door assemblies.** All Side-swinging door assemblies and other entry/egress systems shall be impacted within 6 inches (152.4 mm) of an interface hinge joint, within 6 inches (152.4 mm) of an upper latch point and within 6 inches (152.4 mm) of center primary latches or operators as shown in Figure 803.9.4.1(1) 804.9.5(1).

For double door assemblies, a single door leaf shall receive three impacts as shown in Figure 803.9.4.1(2) 804.9.5(2) plus an additional impact on a center meeting point or mullion.

For double door assemblies with each door leaf containing identical hardware, a single one door leaf shall receive the same three impacts as a single door leaf as shown in Figure 804.9.5(2) plus an additional impact on a center meeting point or mullion as shown in Figure 804.9.5(2) 803.9.4.1(2).

For double door assemblies where one or more hardware components differ between door leaves, each door leaf shall receive the same three impacts as a single door and an additional impact on a center meeting point or mullion as shown in Figure 804.9.5(2) 803.9.4.1(2). No more than four impacts shall be made on one specimen. Where more than four impacts are required, multiple identical test specimens shall be utilized. Impacts shown in Figure 804.9.5(1) 803.9.4.1(1) or Figure 804.9.5(2) 803.9.4.1(2), as applicable, shall occur on the same test specimen.

**Exception:** More than four impacts shall be permitted to be made on a single specimen with mutual consent of the test sponsor and test laboratory.

Where the door contains glazed openings with a size less than or equal to 12 inches (305 mm) by 12 inches (305 mm), an additional sample shall be impacted in the center of the glazed opening. Where glazed openings have a dimension greater than 12 inches (305 mm), the glazed opening shall be treated as a window and tested in accordance with Section 804.9.4 of this standard.

(IS-STM 08-21-18 AM)

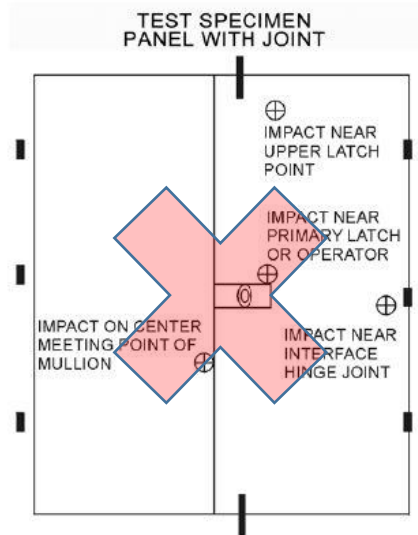
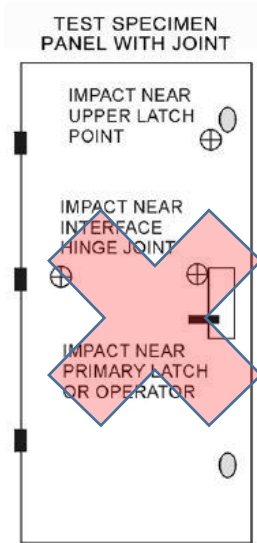

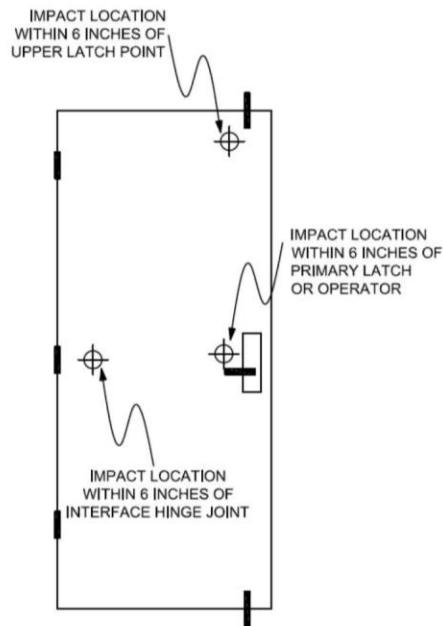

**FIGURE 804.9.5(1) – SINGLE DOOR TEST SPECIMEN**

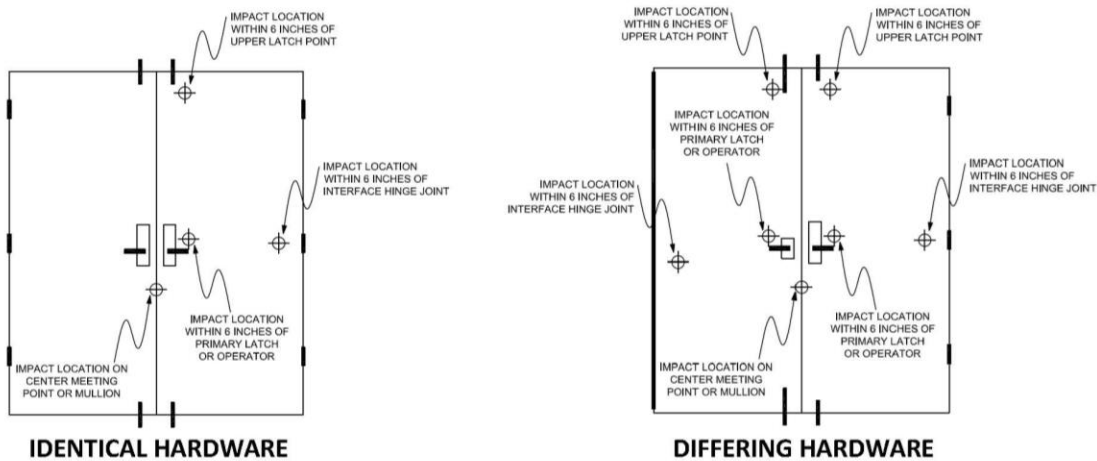

**FIGURE 804.9.5(2) – DOUBLE DOOR TEST SPECIMEN**

(IS-STM 08-17-18 AS, IS-STM 08-18-18 AS, IS-STM 08-19-18 AM, IS-STM 08-21-18 AM)

FIGURE 803.9.4.1(1) 804.9.5(1).

**SINGLE DOORS DOOR ASSEMBLIES AND OTHER ENTRY/EGRESS SYSTEMS**

(IS-STM 08-17-18 AS, IS-STM 08-18-18 AS, IS-STM 08-19-18 AM, IS-STM 08-21-18 AM)

FIGURE 803.9.4.1(2) 804.9.5(2)

**DOUBLE DOORS DOOR ASSEMBLIES AND OTHER ENTRY/EGRESS SYSTEMS**

(IS-STM 08-19-18 AM)

**803.9.4.2 Rolling door assemblies.** For rolling door assemblies, the door shall be impacted at the center of the door, at one bottom corner and within 6 inches (152.4 mm) of primary latches or operators, plus an additional impact centered on a barrel assembly as shown in Figure 803.9.4.2.

**Exception:** The barrel assembly is not subject to the additional impact where the entire barrel assembly is protected by the shelter envelope.

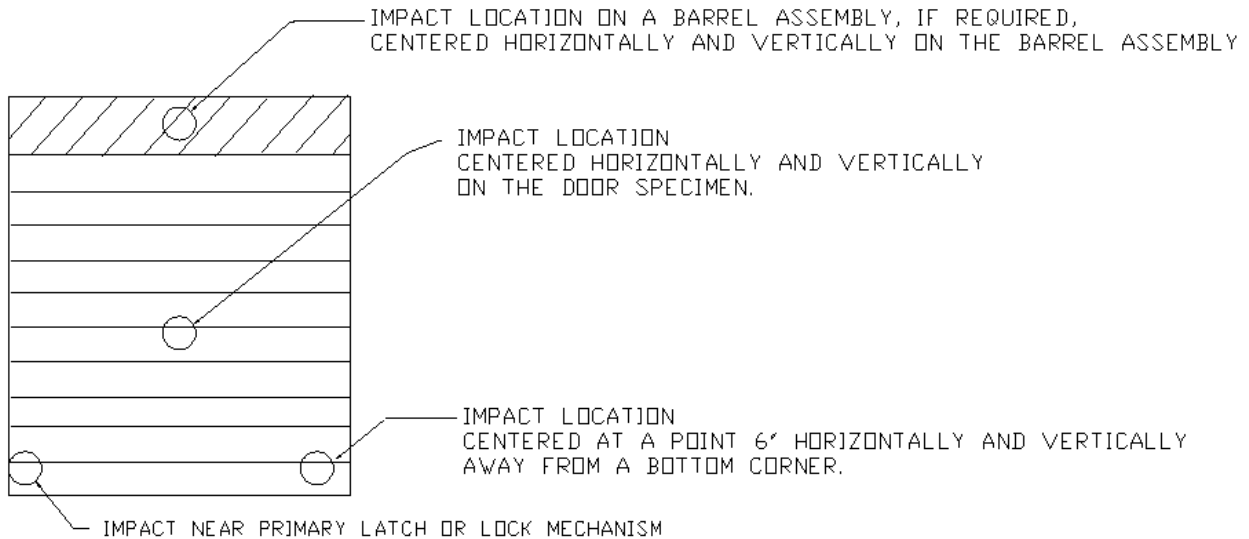

(IS-STM 08-19-18 AM)

**FIGURE 803.9.4.2**  
**ROLLING DOOR ASSEMBLIES**

(IS-STM 08-19-18 AM)

**803.9.4.3 Sectional door assemblies.** For sectional door assemblies, the door shall be impacted at a sectional joint nearing to the center of the door, within the lower two section joints and centered between two vertical stiles, at one bottom corner, and within 6 inches (152 mm) of the primary latches or operators as shown in Figure 803.9.4.3.

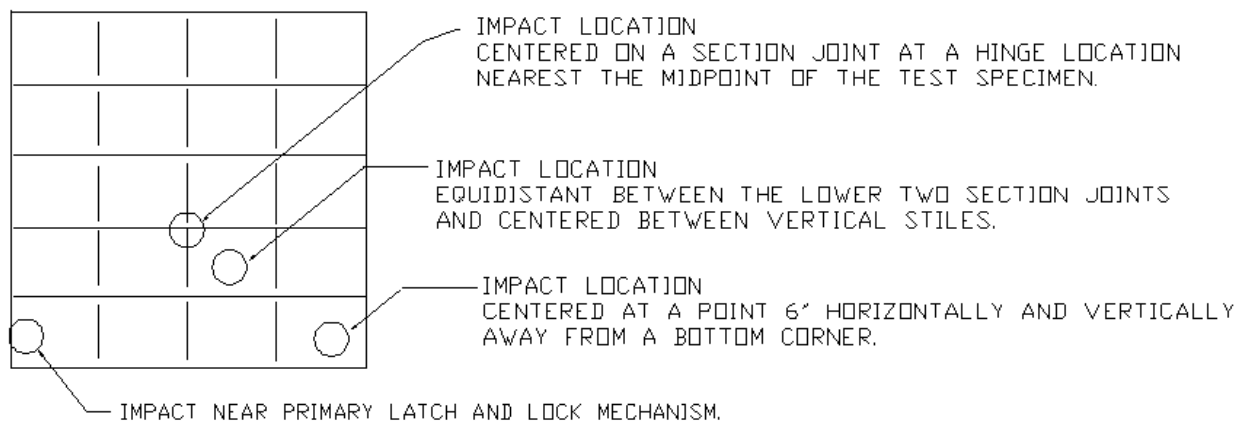

(IS-STM 08-19-18 AM)

**FIGURE 803.9.4.3**  
**SECTIONAL DOOR ASSEMBLIES**



(IS-STM 08-19-18 AM)

**803.9.4.4 Glazed openings in doors.** Where the door contains glazed openings with a height or width of 12 inches (305 mm) or less, an additional sample shall be impacted in the center of the glazed opening. Where the door contains glazed openings with a height or width greater than 12 inches (305 mm), the glazed opening shall be treated as a window and tested in accordance with Section 803.9.5.

(IS-STM 10-01-18 AM, IS-STM 08-17-18 AS, IS-STM 08-18-18 AS, IS-STM 08-21-18 AM)

**803.9.5 804.9.4 Windows Window assemblies and other glazed openings.** All window assemblies and other glazed openings shall be impacted in the center of the smallest glazed section, and at one interface corner as detailed in Figure 803.9.5 804.9.4 (1). Where interior mullions or other glazed section joints and/or latches are present, additional impacts shall be applied on these features as shown in Figure 803.9.5 804.9.4 (2).

No more than two impacts shall be made on one *specimen*. Where more than two impacts are required, multiple identical test *specimens* shall be provided.

**Exception:** More than two impacts may shall be permitted to be made on a test *specimen* by mutual consent of ~~owner~~ test sponsor and *test laboratory*.

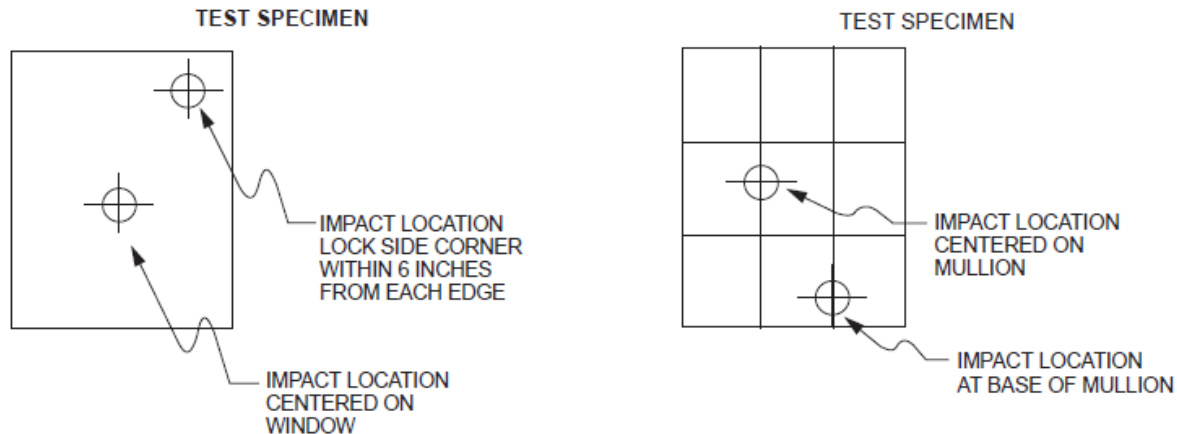

For SI: 1 inch = 25.4 mm.

For SI: 1 inch = 25.4 mm.

(IS-STM 08-17-18 AS, IS-STM 08-18-18 AS)

FIGURE 803.9.5 804.9.4 (1)

**WINDOWS WINDOW ASSEMBLIES AND OTHER GLAZED OPENINGS**

(IS-STM 08-17-18 AS, IS-STM 08-18-18 AS)

803.9.5 804.9.4 (2)

**WINDOWS WINDOW ASSEMBLIES AND OTHER GLAZED OPENINGS**

(IS-STM 08-06-18 AS, IS-STM 08-17-18 AS, IS-STM 08-18-18 AS)

**803.9.6 804.9.6 Other Impact-protective systems.** All shutter assemblies and other *impact-protective systems* shall be impacted in the center of the closed opening, and at one interface corner as detailed in Figure 803.9.6 804.9.6 (1). Panels and interface joints shall be additionally impacted onto the same unit as shown in Figure 803.9.6 804.9.6 (2). Interface hinge joints and primary latches, where present, shall be impacted as shown in Figure 803.9.4 804.9.5(2) on an additional *specimen*. All ~~shutter assemblies and~~ impact protection systems that include swinging door assemblies with latching hardware shall be tested in accordance with Section 803.9.4 804.9.5.

Where an interior stud or support is present, additional impacts onto the same unit shall be performed within 3 inches (76.2 mm) of the stud and support, and directly on the stud support, as detailed in Figure 803.9.2 804.9.2(1) or 803.9.2 804.9.2 (2).

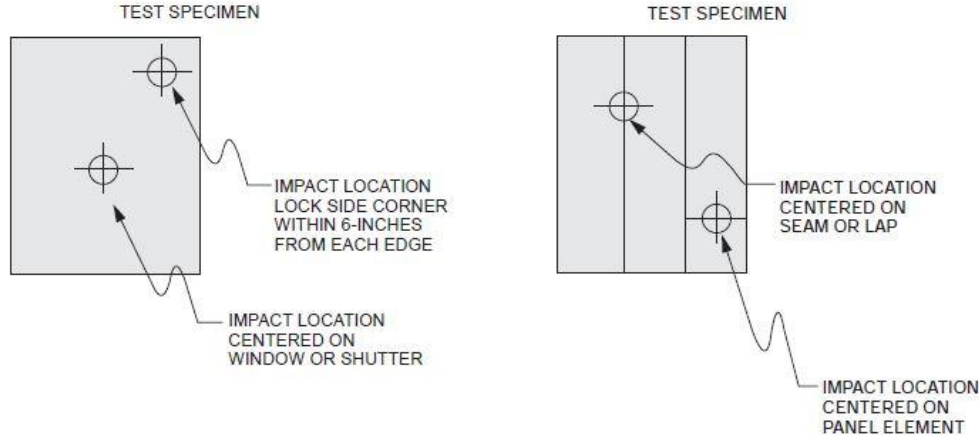

For SI: 1 inch = 25.4 mm.

(IS-STM 08-17-18 AS, IS-STM 08-18-18 AS)  
**FIGURE 803.9.6 804.9.6 (1)**  
**SHUTTERS OR OTHER IMPACT PROTECTION SYSTEMS**

(IS-STM 08-17-18 AS, IS-STM 08-18-18 AS)  
**FIGURE 803.9.6 804.9.6 (2)**  
**SHUTTERS OR OTHER IMPACT PROTECTION SYSTEMS**

(IS-STM 08-18-18 AS, IS-STM 10-07-18 AM, IS-STM 06-04-18 AM)

**803.9.7 804.9.7 Alcove or baffled storm shelter entry systems.** Debris impact testing described in this section required for ~~alcove/ or baffled access/egress storm shelter entry systems~~ meeting the requirements of Sections 304 and 305. See Figure 803.9.7 804.9.7 illustrates an ~~alcove/ or baffle storm shelter entry system~~. Debris impact test requirements are presented for systems for which that comply with one of the following:

1. Storm debris impacts at least two *impact-protective systems* meeting the requirements of Section 306.2 prior to entering the *protected occupant area*. Straight missile paths and elastic impacts are assumed in determining missile trajectories. Test requirements for this type of system are presented in Section 803.9.7.1 804.9.7.4. Examples of this type of system are shown in Figure 803.9.7.1 804.9.7.4. The boundary between the *protected occupant area* and the unprotected occupant area shall be clearly marked on the floor and walls of the *storm shelter*.
2. Storm debris impacts initially an *impact-protective system* meeting the requirements of Section 306.2 and possibly rebounds to impact an ~~entry door~~ a *door assembly*. Straight missile paths and elastic impacts are assumed in determining missile trajectories. The debris test requirements for this type of system are presented in Section 803.9.7.2 804.9.7.2. Examples of this type of system are shown in Figures 803.9.7.1 804.9.7.4 and 803.9.7.2 804.9.7.2.
3. Storm debris impact on an ~~entry door~~ a *door assembly* is limited to an angle less than 90 degrees (1.57 rad) by *impact-protective systems*. The debris test requirements for this type of system are presented in Section 803.9.7.3 804.9.7.3. Examples of this type of system are shown in Figure 803.9.7.3 804.9.7.3.

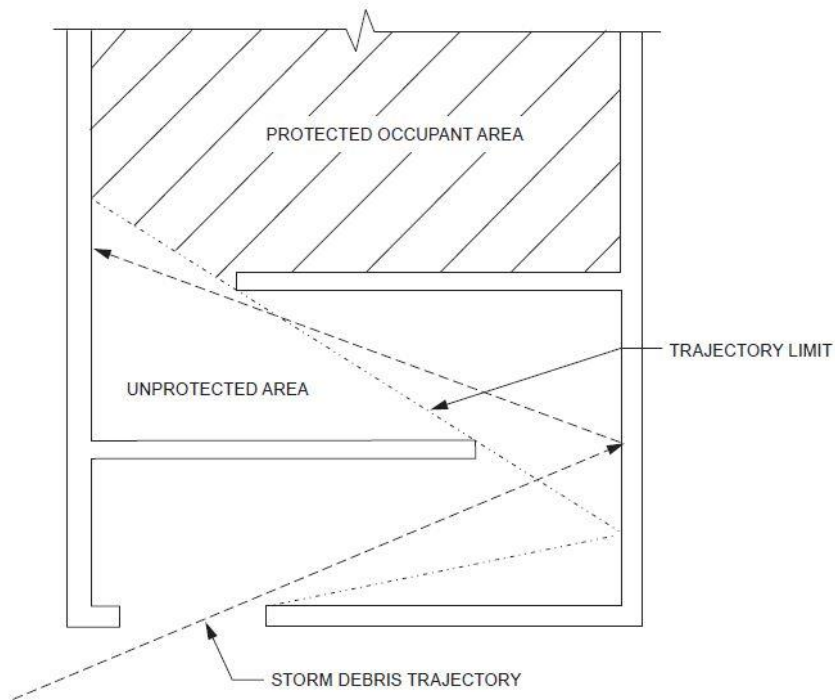

(IS-STM 08-18-18 AS)  
 FIGURE 803.9.7 804.9.7  
**ALCOVE/ OR BAFFLED STORM SHELTER ENTRY SYSTEM**

(IS-STM 10-04-18 AS, IS-STM 08-18-18 AS, IS-STM 10-07-18 AM, IS-STM 06-04-18 AM)

**803.9.7.1 804.9.7.1 Alcove/ or baffled storm shelter entry systems for which no testing is required.** Storm shelter entrances, whether provided with a door assembly or not, that are protected by an alcove or baffled storm shelter entry system that require missiles to impact at least two surfaces meeting the requirements of Section 306.2 prior to arriving at the protected occupant area shall not be required to undergo debris impact testing. See Figure 803.9.7.1 804.9.7.1 for an example. ~~When~~ Where a solid door assembly is installed as a closure for this type of entry system or to meet the fire-resistance requirements in Section 603, the door assembly need not meet the wind load requirements of Section 304.

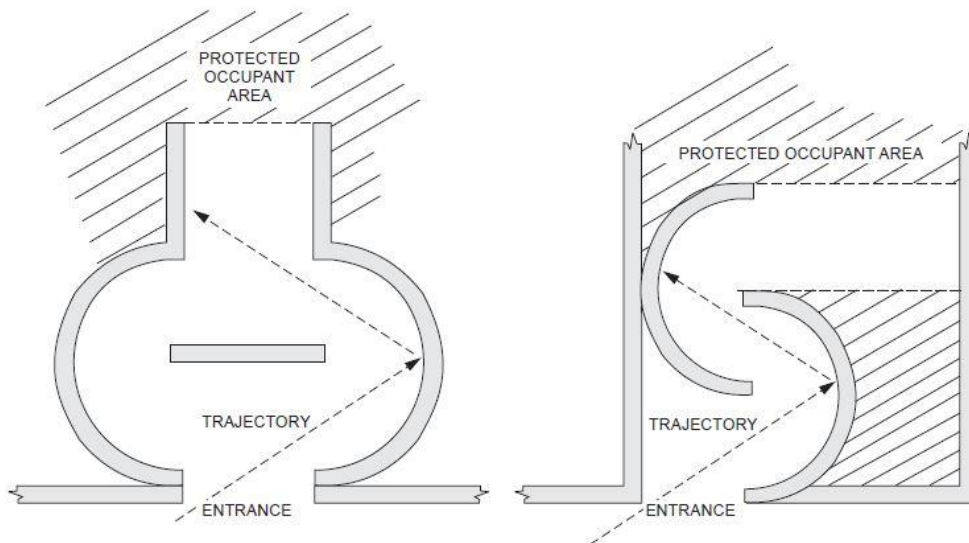

(IS-STM 08-18-18 AS, IS-STM 06-04-18 AM-CC)  
 FIGURE 803.9.7.1 804.9.7.1

**ALCOVE/ OR BAFFLED STORM SHELTER ENTRY SYSTEMS FOR WHICH NO DOOR TESTING IS REQUIRED**

(IS-STM 08-18-18 AS, IS-STM 10-07-18 AM)

**803.9.7.2 804.9.7.2 Door assembly subject to rebound impact.** Where the *alcove or baffled storm shelter entry system* prevents a first impact of the design missile on the door assembly but the door assembly is subject to a rebounded *rebound impact* of the design missile after it has impacted one surface meeting the requirements of Section 306.2 (see Figure 803.9.7.2 804.9.7.2 for an example), then a door assembly shall meet the wind load requirements of Section 304 and the debris impact requirements of Section 305 except that the missile shall be, at a minimum, a 9-pound sawn lumber 2 by 4 traveling at 50 feet per second (15.2 m/s). Entry systems having ~~doors~~ door assemblies that are protected from the initial and first rebounded *rebound impacts* of debris shall comply with the requirements of Section 803.9.7.1 804.9.7.1.

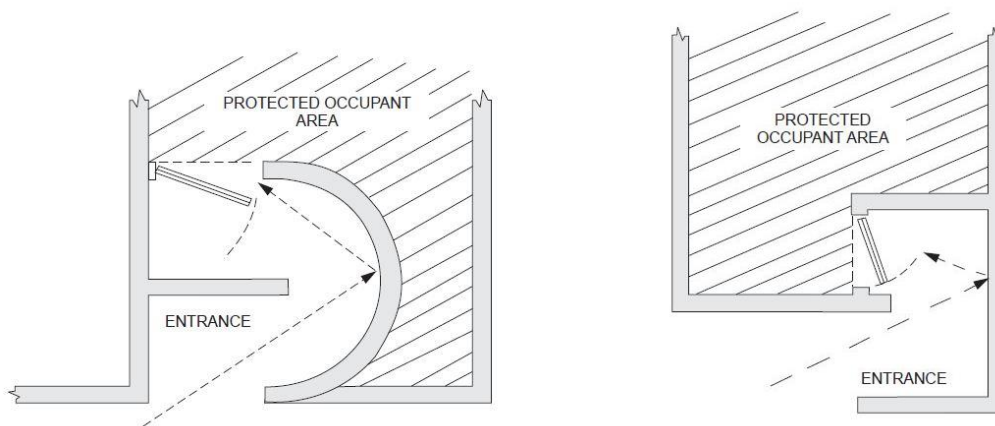

(IS-STM 08-18-18 AS)

**FIGURE 803.9.7.2 804.9.7.2**

**DOORS DOOR ASSEMBLIES SUBJECT TO REBOUND IMPACT**

(IS-STM 08-18-18 AS, IS-STM 10-07-18 AM, IS-STM 06-04-18 AM, IS-STM 08-24-18 AS)

**803.9.7.3 804.9.7.3 Door assemblies subject to first impact.** ~~If~~ Where a first-strike angle missile will impact on the door assembly is possible (see Figure 803.9.7.3 804.9.7.3 for an example) ~~then the door is deemed suitable if the door assembly meets~~ shall meet the wind load requirements of Section 304, the fire-resistance requirements of Section 603, and the door assembly meets one of the following debris impact criteria:

1. The door assembly withstands the impact of a missile specified in Section 305 striking the door assembly at an angle closest to perpendicular to the plane of the door that the missile might strike in the shelter application; or
2. The door assembly is tested following procedures specified in Section 305 or a door assembly is selected that has withstood missile impacts by the design missile striking perpendicular to the surface with speed equal to or greater than the storm shelter design missile's velocity component perpendicular to the door assembly for the most critical angle that can occur in the application.

The minimum debris impact criterion for the door assembly shall be an impact perpendicular to the door assembly of a 9-pound sawn lumber 2 by 4 traveling at 50 feet per second [34 mph (15.2 m/s)].

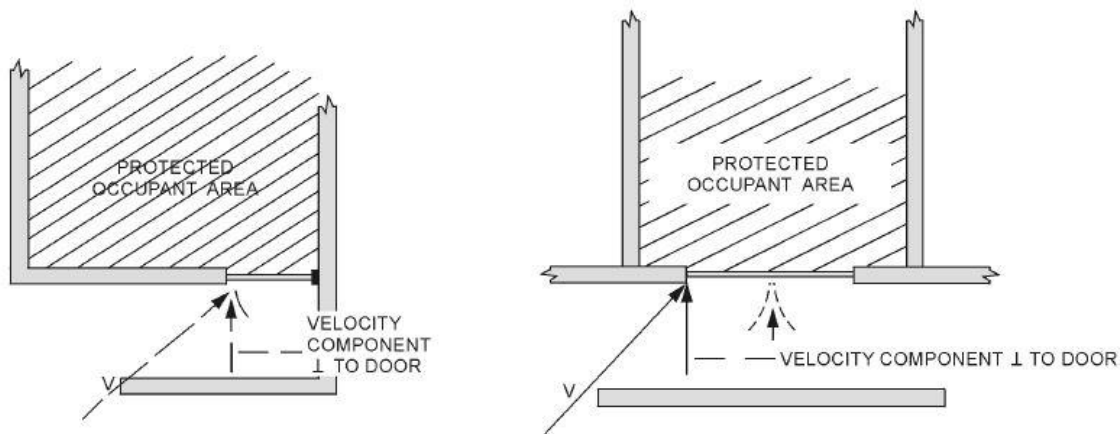

(IS-STM 08-18-18 AS)  
**FIGURE 803.9.7.3 804.9.7.3**  
**DOORS DOOR ASSEMBLY SUBJECT TO FIRST IMPACT**

(IS-STM 08-20-18 AM)  
**803.10 804.10 Pass/ or fail.** The pass/ or fail criteria for missile impact testing shall be in accordance with this section.

(IS-STM 08-20-18 AM)  
**803.10.1 804.10.1 Perforation.** Any perforation of the interior surface of the tested component of the *storm shelter envelope* by the design missile shall constitute a failure. For *impact-protective systems*, perforation or deflection that would result in impact of the protected component constitutes a failure.

(IS-STM 08-07-18 AM, IS-STM 02-09-18 AM)  
**803.10.2 804.10.2 Dislodgment and disengagement.** *Specimens* and load-bearing fasteners, where used, shall not become disengaged or dislodged during the test procedures so as to endanger occupants. Disengagement or dislodgement that occurs in a test shall be demonstrated to not endanger occupants be harmless by failing to perforate a #70 unbleached kraft paper witness screen. The with its surface of the witness screen shall be secured in place on a rigid frame installed within not more than 5 inches (127 mm) of the interior surface of the shelter from the innermost component deemed by the testing agency test laboratory to be most susceptible to disengagement or dislodgement. The rigid frame shall maintain tautness of the kraft paper and shall have continuous supports in one direction at intervals no greater than 3 feet (914 mm).

(IS-STM 08-07-18 AM, IS-STM 02-09-18 AM)  
**803.10.3 804.10.3 Spall.** Excessive spall shall not be released from the interior surface of any specimen during the test procedures so as to endanger occupants. Excessive spall is defined as that which perforates a #70 unbleached kraft paper witness screen with its. The surface of the witness screen shall be secured in place on a rigid frame installed not more than 5 inches (127 mm) from the interior innermost surface of the test specimen deemed by the testing agency test laboratory to be most susceptible to spalling. The witness screen rigid frame shall maintain tautness of the kraft paper and shall have continuous supports in one direction at intervals no greater than 3 feet (914 mm).

**Exception:** Where warnings are to be provided marking the protected occupant area beyond the 5-inch (127-mm) limit defined above, the witness screen is permitted to be positioned at the boundary of the protected area, and excessive spall defined as that which will perforate the witness screen in this position.

**803.10.4 804.10.4 Permanent deformation.** Permanent deformation of an interior surface of the test *specimen* shall be determined by measuring the distance from a straight edge held between two undeformed points on the

*specimen*. The maximum permanent deformation shall be measured to the nearest 1/8 inch (3.2 mm) and shall not exceed 3 inches (76.2 mm).

## **SECTION 804 805 PRESSURE TESTING**

**804.1 805.4 Apparatus.** The general description of the apparatus for performing the pressure testing requirements of this standard is detailed in Section 6 of ASTM E330 when performing the static pressure test, or ASTM E1886 when performing the cyclic test. Any equipment, properly certified, calibrated and approved by a qualified lab, capable of performing this test, within the allowable tolerance, is permitted.

**804.2 805.2 Calibration.** Calibration of the pressure measuring system shall be performed in accordance with the procedure detailed in Section 9 of ASTM E330 or ASTM E1886.

**(IS-STM 08-08-18 AM, IS-STM 08-09-18 AM, IS-STM 08-10-18 AM, IS-STM 08-15-18 AS, IS-STM 03-11-18 AM)**

**804.3 805.3 Cyclic pressure testing after impact.** Test *specimens* requiring cyclic pressure testing to establish the ability to meet the wind pressure requirements set forth in Section 304 of this standard shall be cyclic tested in accordance with ASTM E1886 using the loading sequence detailed in Table 1 of ASTM E1886 specified to the *design wind pressure* as defined in Section 304.4. The test *specimens* used shall be the same test *specimens* that received impacts in accordance with Section 804. Cyclic pressure testing procedures shall be performed in accordance with the Air Pressure Cycling criteria as detailed in Sections 11.1 through 11.2.11 of ASTM E1886.

**Exception:** The maximum allowable cycle time for *specimens* over 75 square feet (7 square M) in area shall be permitted to be calculated using the following equation:

Maximum allowable cycle time in seconds = (area of *specimen* (in sq. ft.) – 75) x (0.06) + 3

In no case shall the maximum cycle time exceed 10 seconds.

**804.4 805.4 Testing temperature.** The testing shall be conducted at room temperature in the range of 59°F (15°C) to 95°F (35°C).

## **SECTION 805 806 PRESSURE TESTING PROCEDURES**

**(IS-STM 08-17-18 AS, IS-STM 08-18-18 AS, IS-STM 03-11-18 AM)**

**805.1 806.4 Pressure testing procedures.** Procedures for pressure testing wall assemblies, roof assemblies, door assemblies, window assemblies and *impact-protective systems* requiring pressure testing are presented in this section in Sections 805.2 through 805.5, as applicable. *Design wind pressures* used for pressure testing of the *storm shelter envelope* shall be in accordance with Section 304.

**(IS-STM 10-04-18 AS, IS-STM 08-18-18 AS, IS-STM 03-11-18 AM, IS-STM 08-11-18 AM)**

**805.2 806.2 Roof and wall assemblies and roof assemblies.** ~~When~~ Where testing of wall assemblies and roof and wall assemblies is required, ~~they~~ such assemblies shall be pressure tested in the as-supplied condition. Pressure testing of roof assemblies shall be conducted in accordance with FM 4474, ASTM E1592, UL1897 or ASTM E330, whichever is applicable, to a pressure 1.2 times the *design wind pressure* or greater. ~~Required~~ Pressure testing of wall assemblies shall be ~~done as detailed in~~ conducted in accordance with ASTM E330 to a pressure equal to or higher than 1.2 times the pressures specified in Section 304 ~~design wind pressure or greater~~.

**(IS-STM 10-04-18 AS, IS-STM 03-11-18 AM)**

**805.3 806.3 Door assemblies.** Door assemblies shall be pressure tested in the as-supplied condition and, ~~when~~ where required, they shall be static pressure tested or cyclically tested as specified in the following sections: Sections 805.3.1 through **805.3.2.2**.

**(IS-STM 08-18-18 AS)**

**805.3.1 806.3.4 Door assemblies without glazing.** Door assemblies without glazing that require testing to meet the qualification of Section 306.3 shall be pressure tested according to procedures specified in ~~this section~~ Sections 805.3.1.1 and 805.3.1.2.

(IS-STM 08-22-18 AM, IS-STM 03-11-18 AM)

**805.3.1.1** ~~806.3.1.1~~ **Door assemblies without glazing for *tornado shelters*.** Door assemblies without glazing for use in *tornado shelters* shall be static pressure tested ~~away from the door stops~~ to a pressure of at least 1.2 times the ~~pressures specified in Section 304~~ design wind pressure or greater. Pressure tests are permitted to be conducted separately from missile impact tests.

(IS-STM 08-22-18 AM, IS-STM 03-11-18 AM)

**805.3.1.2** ~~806.3.1.2~~ **Door assemblies without glazing for *hurricane shelters*.** Door assemblies without glazing for use in *hurricane shelters* shall be static pressure proof tested ~~away from the door stops~~ to a pressure of at least 1.2 times the design wind pressure or greater, then subjected to required debris impact tests, and then to cyclic pressure tests following procedures of ASTM E1886.

Alternatively, door assemblies without glazing for *hurricane shelters* shall be statically pressure tested ~~away from the door stops~~ to a pressure of 1.5 times the design wind pressure or greater before impact tests and then to required debris impact tests. Cyclic pressure testing after impact tests is not required for these door assemblies that have been pressure tested to pressures equal to or greater than 1.5 times the design wind pressure or greater.

(IS-STM 08-12-18 AM, IS-STM 08-18-18 AS)

**805.3.2** ~~806.3.2~~ **Door assemblies with glazing, sidelights or transoms.** Door assemblies with glazing, sidelights or transoms shall be pressure tested according to procedures specified in ~~this section~~ Sections 805.3.2.1 and 805.3.2.2. ~~Where glazed openings are present, with a size of less than or equal to 12 inches by 12 inches (304.8 mm by 304.8 mm), an additional sample shall be impacted in the center of the glazed opening in accordance with Section 804 and cyclic pressure tested as detailed in Section 805.3. Where glazed openings have a dimension greater than 12 inches (304.8 mm), the glazed opening shall be treated as a window and tested in accordance with Section 806.5 of this standard.~~

(IS-STM 08-22-18 AM, IS-STM 03-11-18 AM)

**805.3.2.1** ~~806.3.2.1~~ **Door assemblies with glazing, sidelights or transoms for *tornado shelters*.** Door assemblies with glazing, sidelights or transoms for *tornado shelters* shall be static pressure tested ~~away from the door stops~~ following procedures of ASTM E330 to a pressure of at least 1.2 times the ~~pressures specified in Section 304~~ design wind pressure or greater. Pressure tests are permitted to be conducted separately from debris impact tests.

(IS-STM 08-22-18 AM, IS-STM 03-11-18 AM)

**805.3.2.2** ~~806.3.2.2~~ **Door assemblies with glazing, sidelights or transoms for *hurricane shelters*.** Door assemblies with glazing, sidelights or transoms for *hurricane shelters* shall be static pressure proof tested ~~away from the door stops~~ to a pressure of at least 1.2 times the design wind pressure or greater. Any required debris impact tests shall follow pressure proof testing. After impact tests the door assembly shall be subjected to cyclic pressure tests following procedures of ASTM E1886.

(IS-STM 08-18-18 AS)

**805.4** ~~806.4~~ **Window assemblies and other glazed openings.** Window assemblies and other glazed openings shall be pressure tested according to procedures specified in ~~this section~~ Sections 805.4.1 and 805.4.2.

(IS-STM 08-22-18 AM, IS-STM 03-11-18 AM)

**805.4.1** ~~806.4.1~~ **Window assemblies and other glazed openings for *tornado shelters*.** Window assemblies and other glazed openings for *tornado shelters* shall be static pressure tested ~~away from stops~~ to a pressure of at least 1.2 times the design wind pressure or greater following procedures detailed in ASTM E330. Pressure tests are allowed to be conducted separately from debris impact tests.

(IS-STM 08-22-18 AM, IS-STM 03-11-18 AM)

**805.4.2** ~~806.4.2~~ **Window assemblies and other glazed openings for *hurricane shelters*.** Window assemblies and other glazed openings for *hurricane shelters* shall be static pressure tested ~~away from stops~~ to a pressure of at least 1.2 times the design wind pressure or greater. Any required debris impact tests shall follow pressure proof testing. After impact tests the window assembly shall be subjected to cyclic pressure tests following procedures of ASTM E1886.

**(IS-STM 10-04-18 AS, IS-STM 10-05-18 AM, IS-STM 10-08-18 AS, IS-STM 08-14-18 AM, IS-STM 08-17-18 AS)**  
**805.5 806.5 Other -protective systems.** Where installed, other external impact-protective systems shall be tested for the ability to withstand prescribed pressures if where withstanding pressure is critical to their function ~~when installed~~. Where the only function of devices such as nonoperable, permanently affixed shields or cowlings, ~~whose only function is to protect against debris intrusion, such devices~~ need not be static or cyclic pressure tested ~~when~~ where the shields or cowlings have been designed and anchored to resist the design loads as determined in this standard.

**(IS-STM 10-04-18 AS, IS-STM 10-08-18 AS, IS-STM 08-17-18 AS, IS-STM 03-11-18 AM)**

**805.5.1 806.5.1 Other Impact-protective systems for tornado shelters.** Where installed, other external impact-protective systems for tornado shelters, ~~where the~~ whose ability to withstand wind-induced pressure ~~when installed~~ is critical to their function, such systems shall be static pressure tested following procedures specified in ASTM E330 to a pressure of at least 1.2 times the design wind pressures or greater ~~specified in Section 304~~. Debris impact tests and pressure tests are permitted to be conducted separately.

**Exception:** *Impact-protective systems* with a jamb or stop need to be tested with pressure only away from the stop.

**(IS-STM 10-08-18 AS, IS-STM 08-17-18 AS)**

**805.5.2 806.5.2 Opening Other impact-protective systems devices for hurricane shelters.** Where installed, other external impact-protective systems devices for hurricane shelters, ~~where the~~ whose ability to withstand wind-induced pressure ~~when installed~~ is critical to their function, such devices shall be static pressure tested to a pressure of at least 1.2 times the hurricane shelter design wind pressures specified in Section 304 following the procedures specified in ASTM E330. Cyclic pressure tests conducted in accordance with Section 805.5 shall be conducted after debris impact tests.

**(IS-STM 10-08-18 AS, IS-STM 08-17-18 AS, IS-STM 08-18-18 AS)**

**805.5 806.6 Alcove or baffled storm shelter entry systems.** Any element of the alcove or baffled storm shelter entry system ~~whose~~ with the ability to resist wind-induced pressure that is critical to the function of the alcove or baffled storm shelter entry system shall be designed to meet the requirements of Section 304 or shall be pressure tested in accordance with Section 805 ~~806~~.



## CHAPTER 9

# REFERENCED STANDARDS

This chapter lists the standards that are referenced in various sections of this document. The standards are listed herein by the promulgating agency of the standard, the standard identification, the effective date and title, and the section or sections of this document that reference the standard.

(IS-STM 03-27 AM)

### **ACI**

American Concrete Institute  
38800 Country Club Drive  
Farmington Hills, MI 48331  
Reston, VA 20191-4400

Standard reference number	Title	Referenced in code section number
ACI 318-19:	Building Code Requirements for Structural Concrete.....	307.2

(IS-STM 09-01-18 AM, IS-STM 09-02-18 AS)

### **ASCE**

American Society of Civil Engineers  
 Structural Engineering Institute  
 1801 Alexander Bell Drive  
 Reston, VA 20191-4400

Standard reference number	Title	Referenced in code section number
7—10 <u>16</u> 302.1,	Minimum Design Loads for Buildings and Other Structures with Supplement No. 1....	301.1, 302.2, 303.1, 303.2, 304.1, 304.7
24—05 <u>14</u>	Flood Resistant Design and Construction.....	401.3

(IS-STM 09-01-18 AM, IS-STM 09-03-18 AS) (IS-STM 08-11-18 AM)

### **ASTM**

ASTM International  
 100 Barr Harbor Drive  
 West Conshohocken, PA 19428-2959

Standard reference number	Title	Referenced in code section number
C920—08 <u>14a</u>	Standard Specification for Elastomeric Joint Sealants	
E330/E330M—02 <u>14</u>	Standard Test Method for Structural Performance of Exterior Windows, Doors, Skylights and Curtain Walls by Uniform Static Air Pressure Difference	805.1, 805.2, 806.2, 806.3.2.1, 806.4.1, 806.5.1, 806.5.2
<del>E631—06</del>	<del>Terminology of Building Constructions</del> .....	<del>802.1</del>
E1592-05 (Reapproved 2017)	Standard Test Method for Structural Performance of Sheet Metal Roof and Siding Systems by Uniform Static Air Pressure Difference	
E1886—05 <u>13A</u>	Standard Test Method for the Performance of Exterior Windows, Curtain Walls, Doors and Impact Protective Systems Impacted by Missile(s) and Exposed to Cyclic Pressure Differentials .....	805.1, 805.2, 805.3, 806.3.1.2, 806.3.2.2, 806.4.2

Note: The reference to this standard was deleted in from the 2008 edition. It is not referenced in the 2014 edition, so this is an erratum and will be deleted.

<del>E1996—12 14a</del>	<del>Specification for Performance of Exterior Windows, Curtains Walls, Doors and Impact Protective Systems Impacted by Windborne Debris in Hurricane</del>	<del>306.3.2</del>
-------------------------	-------------------------------------------------------------------------------------------------------------------------------------------------------------	--------------------

## DOC

U.S. Department of Commerce  
National Institute of Standards and Technology  
100 Bureau Drive Stop 3460  
Gaithersburg, MD 20899

Standard reference number	Title	Referenced in code section number
<b>PS 20—10</b>	<b>American Softwood Lumber Standard</b>	804.4.1

### (IS-STM 08-11-18 AM)

## FM

FM Approvals  
Headquarters Office  
1151 Boston-Providence Turnpike  
P.O. Box 9102  
Norwood, MA 02062

Standard reference number	Title	Referenced in code section number
4474—2011:	American National Standard for Evaluating the Simulated Wind Uplift Resistance of Roof Assemblies Using Static Positive and/or Negative Differential Pressures	

### (IS-STM 09-01-18 AM)

## ICC

International Code Council, Inc.  
500 New Jersey Ave, NW  
6th Floor  
Washington, D.C. 20001

Standard reference number	Title	Referenced in code section number
IBC— <del>15</del> 21	International Building Code®	501.6
ICC A117.1— <del>09</del> 17	Accessible and Usable Buildings and Facilities	504.1.1

### (IS-STM 07-12-18 AM)

## ISEA

International Safety Equipment Association  
1901 North Moore Street, Suite 808,  
Arlington, Virginia 22209

Standard reference number	Title	Referenced in code section number
---------------------------	-------	-----------------------------------

ANSI/ISEA Z308.1-2015 Minimum Requirements for Workplace First Aid Kits and Supplies

**NFPA**

National Fire Protection Association  
1 Batterymarch Park  
Quincy, MA 02269-9101

---

Standard reference number	Title	Referenced in code section number
<b>NFPA-10—13</b>	<b>Portable Fire Extinguishers .....</b>	<b>602.2</b>

---

**(IS-STM 09-01-18 AM, IS-STM 09-02-18 AS, IS-STM 09-03-18 AS)**

**TMS**

The Masonry Society  
105 South Sunset Street, Suite Q  
Longmont, CO 80501

---

Standard reference number	Title	Referenced in code section number
602—2014 <u>2016</u>	Specification for Masonry Structures	

---

**(IS-STM 08-11-18 AM)**

**UL**

UL LLC  
333 Pfingsten Road  
Northbrook, IL 60062.2096

---

Standard reference number	Title	Referenced in code section number
<u>UL1897-2015</u>	<u>Standard for Safety for Uplift Tests for Roof Covering Systems</u>	

---