



And

The City of



...Partnering for the future, Today!

- The purpose of various Building Codes are to provide minimum standards to safeguard life, health, property, and public welfare by regulating and controlling the design, construction, quality of materials, use and occupancy, location and maintenance of all buildings, structures and certain equipment.
- Design Professionals, Inspectors and Tradespersons are licensed to protect the public

# Purpose of Building Codes

1780 BC

“If a builder build a house for someone and does not construct it properly, and the house which he built fall in and kill its owner, then that builder shall be put to death.”

# Babylonian Code of Hammurabi



# First United States Codes

- First on record was in 1625 in what was know as New Amsterdam (New York).
- Addressed fire prevention and governed the types of roofing materials that could be used to protect from chimney sparks.
- Chicago fire of 1871 caused many large cities to create their own municipal building codes.



- The first major model-code group
- Founded in 1915
- Located in Country Club Hills, Illinois
- Codes were adopted predominantly in the north central and northeastern states

# Building Officials and Code Administration (BOCA)

- Formed in 1922
- Located in Whittier, CA
- First edition of the Uniform Building Code published in 1927
- Adopted by states west of the Mississippi River



# International Conference of Building Officials (ICBO)



- Headquartered in Birmingham, Alabama
- Founded in 1940
- Published the Southern Building Code
- Widely accepted in the southeast

# Southern Building Code Conference





- Uniform system of codes was necessary
- Representatives from each of the code organizations formed the ICC in 1994
- First edition of the International Building Code published in 2000

# International Code Council (ICC)





And with all of this  
we still have this?



# Keys to a SMOOTH Permit Approval Process:

- If there is some facet of the project that is out of the ordinary, arrange for a presubmission meeting with the review team as soon as plans are of sufficient completeness to understand the project.
- Complete and accurate Building plans and plot plan.
- Include Correct Project info, proper address/location, contact info
- RESCheck report properly completed establishing compliance with the 2012 International Energy Conservation Code.
- Be familiar with the IRC Plan review checklist!



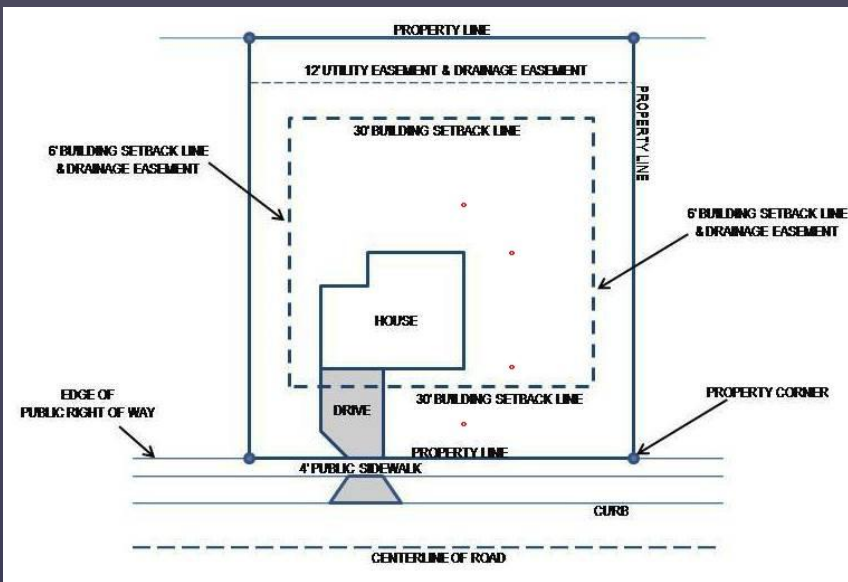

Plot plan if you are expanding the footprint or building a new structure

Detailed Building Plans

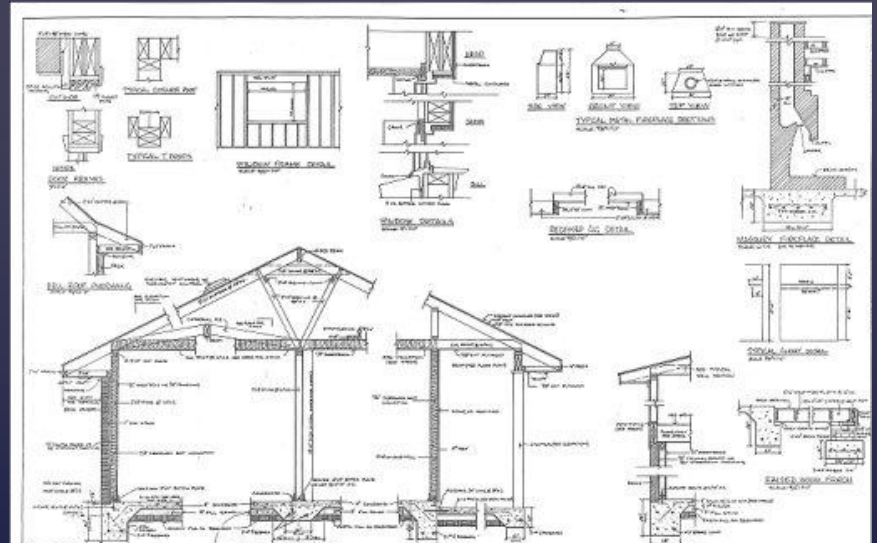

What Do I need for a Permit?



- What are our goals?
  - Streamline permit approval process when possible.
    - Some permits over the counter.
    - Some permits from our website.
  - Assist applicants with solutions to their project challenges.

- COMING SOON!!!  
Complete On-line permitting and payment

www.cityofrockhill.com

Departments » Planning and Development

## PERMIT APPLICATION CENTER

Font Size: [+](#) [-](#) [Share & Bookmark](#) [Feedback](#) [Print](#)

Building permits and inspections ensure the basic safety of the buildings in our community. We have worked hard to streamline the permit approval process wherever possible. While more involved projects will require detailed review by our team of plan reviewers, many permits can be issued over the counter, and certain simple permits can be issued from our website for established customers. We take our business (and yours) seriously. It's easy to identify problems, but our staff is encouraged to roll up their sleeves and help you come up with the solutions. Click below to find out more details about permits.

[Residential Building Permits](#)
[Commercial Building Permits](#)
[Inspections](#)
[Mechanical Permits](#)

[Zoning Permits](#)
[Sign Permits](#)
[Other Permits & Information](#)
[Work Exempt from Permits](#)

[Forms](#)
[GIS Maps](#)
[Online Permits, Inspections & Plans](#)
[FAQ's](#)
[Map Search](#)

How are we doing? Let us know by providing feedback on our [Online Comment Card](#).

Home • Departments • Government • Services • Stay Informed • How Do I? • Contact Us • Site Map

©2014 Rock Hill, SC. All Rights Reserved. | Created by Vision Internet

[f](#)
[t](#)
[You Tube](#)

We try to make it as easy as possible

Examples:

- New houses or buildings
- Room additions or expansions
- Structural repairs, remodeling and alterations
- Accessory structures
- Carports and detached garages
- Plumbing, heating and air, electrical, gas work
- Re-roofing, new siding, replacement windows

# When do you need a permit?

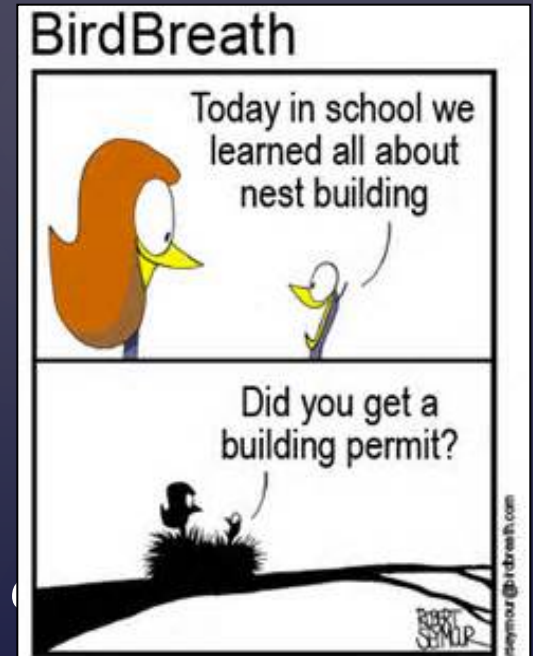

# Overview of Development Activities

## Permits

□ The total number of permits December 2014 is 314, up by 66% compared to December of 2013. To date, the number of permits issued is 2722, up by 105% compared to this time last fiscal year.

□ The total number of new single-family home permits issued this month is 13, down by 52% compared to December of last year. To date, the number of single family home permits issued is 118, down by 11% compared to this time last fiscal year.

□ Seven multi-family apartment buildings with 168 units were permitted this month, up from none in December of last year. To date, a total of 16 buildings with 384 units have been permitted, up from none this time last fiscal year.

□ Eight new commercial buildings were permitted this month, up from none in December of last year. To date, the number of non-residential permits issued is 21, up 163% from this time last fiscal year.

## Inspections

□ The number of building inspections performed this month is 1425, up by 23% from last December. Inspectors performed an average of 17.8 inspections per day this month. To date, the number of inspections performed is 8829, up by 32% compared to this time last fiscal year.

## Comparison of Permits Issued

(compared to same month in previous fiscal year)

<i>Fiscal Year 2013 - 2014</i>				<i>Fiscal Year 2014 - 2015</i>			<i>Percent Change</i>		
<b>Month</b>	<b>No . of Permits</b>	<b>Valuation</b>	<b>Fees Paid</b>	<b>No . of Permits</b>	<b>Valuation</b>	<b>Fees Paid</b>	<b>Change in # of Permits from Last Year</b>	<b>Change in Valuations from Last Year</b>	<b>Change in Fees Paid from Last Year</b>
July	269	\$9,715,307	\$60,604	617	\$26,995,775	\$116,520	129%	178%	92%
August	217	\$23,503,439	\$81,111	547	\$25,193,218	\$120,103	152%	7%	48%
September	219	\$88,984,015	\$240,948	468	\$24,878,591	\$117,028	114%	-72%	-51%
October	229	\$7,694,352	\$46,821	456	\$36,213,409	\$143,015	99%	371%	205%
November	204	\$21,677,278	\$83,295	320	\$31,593,046	\$128,456	57%	46%	54%
December	189	\$7,552,379	\$50,127	314	\$39,787,069	\$149,634	66%	427%	199%
January	228	\$13,907,923	\$46,909						
February	162	\$4,703,456	\$27,933						
March	283	\$15,805,061	\$82,304						
April	258	\$16,358,105	\$83,390						
May	283	\$40,920,923	\$146,974						
June	429	\$20,843,858	\$97,673						
<b>Total</b>	<b>2,970</b>	<b>\$271,666,096</b>	<b>\$1,048,089</b>	<b>2,722</b>	<b>\$184,661,108</b>	<b>\$774,756</b>			



# Why are building permits important?

Safety!!!



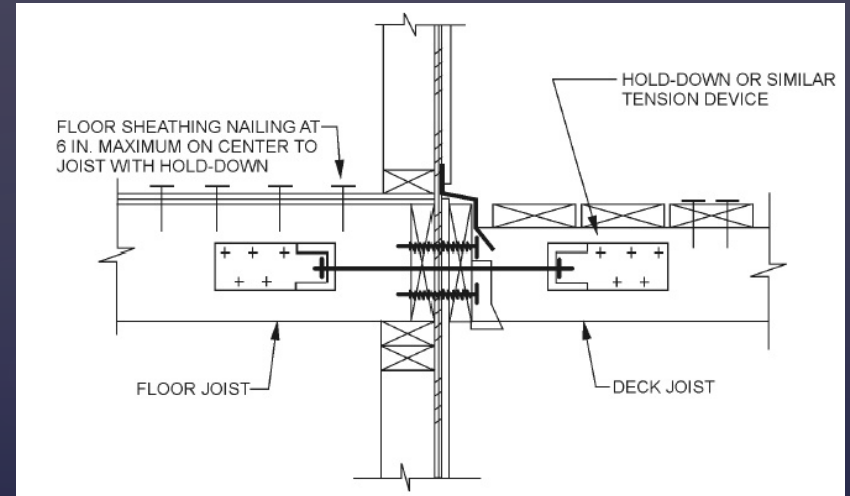
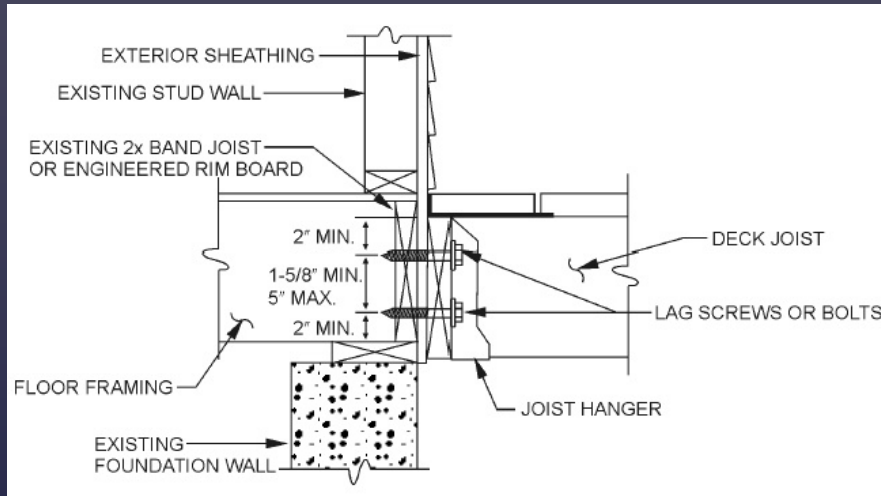
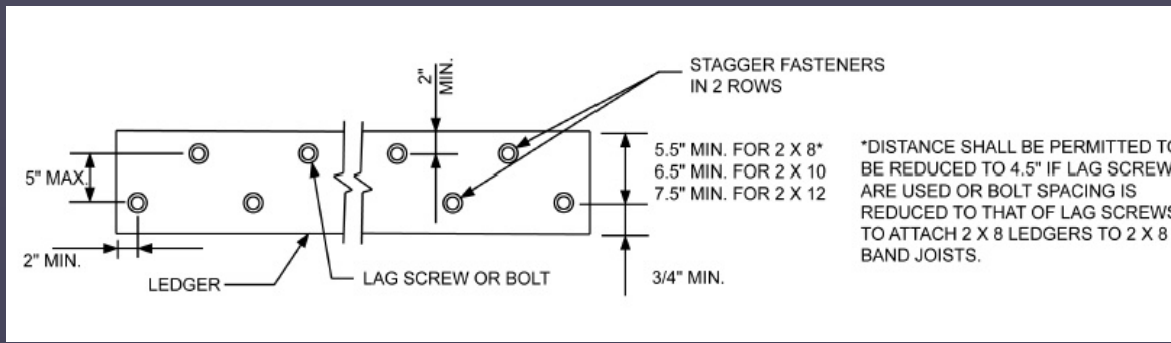

Specific Standards create consistency

State Licenses are required for most building trade activities.

South Carolina Contractor's Licensing Board Contact Info:

Telephone: (803) 896-4686

Email: [clbhelp@lrr.sc.gov](mailto:clbhelp@lrr.sc.gov)

The City of Rock Hill also requires a City Business License prior to the issuance of a permit



**Contractor Licensing Required!!!**

*Thank you!!!!!!!*

Mike Nugent, C.B.O.  
Building Official  
Planning & Development  
City of Rock Hill  
P.O. Box 11706  
155 Johnston Street (29731-1706)  
Rock Hill, South Carolina 29731-1706  
o: 803-329-5598

[Mike.Nugent@cityofrockhill.com](mailto:Mike.Nugent@cityofrockhill.com)



**ROCK HILL**  
SOUTH CAROLINA

*Always on.*